

To our customers,

---

## Old Company Name in Catalogs and Other Documents

---

On April 1<sup>st</sup>, 2010, NEC Electronics Corporation merged with Renesas Technology Corporation, and Renesas Electronics Corporation took over all the business of both companies. Therefore, although the old company name remains in this document, it is a valid Renesas Electronics document. We appreciate your understanding.

Renesas Electronics website: <http://www.renesas.com>

April 1<sup>st</sup>, 2010  
Renesas Electronics Corporation

Issued by: Renesas Electronics Corporation (<http://www.renesas.com>)

Send any inquiries to <http://www.renesas.com/inquiry>.

## Notice

1. All information included in this document is current as of the date this document is issued. Such information, however, is subject to change without any prior notice. Before purchasing or using any Renesas Electronics products listed herein, please confirm the latest product information with a Renesas Electronics sales office. Also, please pay regular and careful attention to additional and different information to be disclosed by Renesas Electronics such as that disclosed through our website.
2. Renesas Electronics does not assume any liability for infringement of patents, copyrights, or other intellectual property rights of third parties by or arising from the use of Renesas Electronics products or technical information described in this document. No license, express, implied or otherwise, is granted hereby under any patents, copyrights or other intellectual property rights of Renesas Electronics or others.
3. You should not alter, modify, copy, or otherwise misappropriate any Renesas Electronics product, whether in whole or in part.
4. Descriptions of circuits, software and other related information in this document are provided only to illustrate the operation of semiconductor products and application examples. You are fully responsible for the incorporation of these circuits, software, and information in the design of your equipment. Renesas Electronics assumes no responsibility for any losses incurred by you or third parties arising from the use of these circuits, software, or information.
5. When exporting the products or technology described in this document, you should comply with the applicable export control laws and regulations and follow the procedures required by such laws and regulations. You should not use Renesas Electronics products or the technology described in this document for any purpose relating to military applications or use by the military, including but not limited to the development of weapons of mass destruction. Renesas Electronics products and technology may not be used for or incorporated into any products or systems whose manufacture, use, or sale is prohibited under any applicable domestic or foreign laws or regulations.
6. Renesas Electronics has used reasonable care in preparing the information included in this document, but Renesas Electronics does not warrant that such information is error free. Renesas Electronics assumes no liability whatsoever for any damages incurred by you resulting from errors in or omissions from the information included herein.
7. Renesas Electronics products are classified according to the following three quality grades: “Standard”, “High Quality”, and “Specific”. The recommended applications for each Renesas Electronics product depends on the product’s quality grade, as indicated below. You must check the quality grade of each Renesas Electronics product before using it in a particular application. You may not use any Renesas Electronics product for any application categorized as “Specific” without the prior written consent of Renesas Electronics. Further, you may not use any Renesas Electronics product for any application for which it is not intended without the prior written consent of Renesas Electronics. Renesas Electronics shall not be in any way liable for any damages or losses incurred by you or third parties arising from the use of any Renesas Electronics product for an application categorized as “Specific” or for which the product is not intended where you have failed to obtain the prior written consent of Renesas Electronics. The quality grade of each Renesas Electronics product is “Standard” unless otherwise expressly specified in a Renesas Electronics data sheets or data books, etc.
  - “Standard”: Computers; office equipment; communications equipment; test and measurement equipment; audio and visual equipment; home electronic appliances; machine tools; personal electronic equipment; and industrial robots.
  - “High Quality”: Transportation equipment (automobiles, trains, ships, etc.); traffic control systems; anti-disaster systems; anti-crime systems; safety equipment; and medical equipment not specifically designed for life support.
  - “Specific”: Aircraft; aerospace equipment; submersible repeaters; nuclear reactor control systems; medical equipment or systems for life support (e.g. artificial life support devices or systems), surgical implantations, or healthcare intervention (e.g. excision, etc.), and any other applications or purposes that pose a direct threat to human life.
8. You should use the Renesas Electronics products described in this document within the range specified by Renesas Electronics, especially with respect to the maximum rating, operating supply voltage range, movement power voltage range, heat radiation characteristics, installation and other product characteristics. Renesas Electronics shall have no liability for malfunctions or damages arising out of the use of Renesas Electronics products beyond such specified ranges.
9. Although Renesas Electronics endeavors to improve the quality and reliability of its products, semiconductor products have specific characteristics such as the occurrence of failure at a certain rate and malfunctions under certain use conditions. Further, Renesas Electronics products are not subject to radiation resistance design. Please be sure to implement safety measures to guard them against the possibility of physical injury, and injury or damage caused by fire in the event of the failure of a Renesas Electronics product, such as safety design for hardware and software including but not limited to redundancy, fire control and malfunction prevention, appropriate treatment for aging degradation or any other appropriate measures. Because the evaluation of microcomputer software alone is very difficult, please evaluate the safety of the final products or system manufactured by you.
10. Please contact a Renesas Electronics sales office for details as to environmental matters such as the environmental compatibility of each Renesas Electronics product. Please use Renesas Electronics products in compliance with all applicable laws and regulations that regulate the inclusion or use of controlled substances, including without limitation, the EU RoHS Directive. Renesas Electronics assumes no liability for damages or losses occurring as a result of your noncompliance with applicable laws and regulations.
11. This document may not be reproduced or duplicated, in any form, in whole or in part, without prior written consent of Renesas Electronics.
12. Please contact a Renesas Electronics sales office if you have any questions regarding the information contained in this document or Renesas Electronics products, or if you have any other inquiries.

(Note 1) “Renesas Electronics” as used in this document means Renesas Electronics Corporation and also includes its majority-owned subsidiaries.

(Note 2) “Renesas Electronics product(s)” means any product developed or manufactured by or for Renesas Electronics.

# BIPOLAR ANALOG INTEGRATED CIRCUITS

## $\mu$ PC8106TB, $\mu$ PC8109TB

### SILICON MMIC 2.0 GHz FREQUENCY UP-CONVERTER FOR CELLULAR/CORDLESS TELEPHONES

#### DESCRIPTION

The  $\mu$ PC8106TB and  $\mu$ PC8109TB are silicon monolithic integrated circuits designed as frequency up-converter for cellular/cordless telephone transmitter stage. The  $\mu$ PC8106TB features improved intermodulation and  $\mu$ PC8109TB features low current consumption. From these two version, you can chose either IC corresponding to your system design. These TB suffix ICs which are smaller package than conventional T suffix ICs contribute to reduce your system size.

The  $\mu$ PC8106TB and  $\mu$ PC8109TB are manufactured using NEC's 20 GHz fr NESAT<sup>TM</sup>III silicon bipolar process. This process uses a silicon nitride passivation film and gold electrodes. These materials can protect chip surface from external pollution and prevent corrosion/migration. Thus, this IC has excellent performance, uniformity and reliability.

#### FEATURES

- Recommended operating frequency :  $f_{RFout} = 0.4$  to 2.0 GHz,  $f_{iFin} = 100$  to 400 MHz
- Supply voltage :  $V_{CC} = 2.7$  to 5.5 V
- High-density surface mounting : 6-pin super minimold package
- Low current consumption :  $I_{CC} = 9$  mA TYP. @  $\mu$ PC8106TB  
 $I_{CC} = 5$  mA TYP. @  $\mu$ PC8109TB
- Minimized carrier leakage : Due to double balanced mixer
- Built-in power save function

#### APPLICATION

- Cellular/cordless telephone up to 2.0 GHz MAX (example: PHS, PDC, DCS1800 and so on)

#### ORDERING INFORMATION

Part Number	Package	Marking	Supplying Form	Product Type
$\mu$ PC8106TB-E3	6-pin super minimold	C2D	Embossed tape 8 mm wide. Pin 1, 2, 3 face the tape perforation side.	High IP <sub>3</sub>
$\mu$ PC8109TB-E3		C2G	Qty 3 kpcs/reel.	Low current consumption

**Remark** To order evaluation samples, please contact your local NEC sales office (Part number for sample order:  $\mu$ PC8106TB,  $\mu$ PC8109TB).

#### Caution Electro-static sensitive devices

The information in this document is subject to change without notice. Before using this document, please confirm that this is the latest version.  
Not all devices/types available in every country. Please check with local NEC representative for availability and additional information.

**CONTENTS**

1. PIN CONNECTIONS..... 3

2. PRODUCT LINE-UP..... 3

3. INTERNAL BLOCK DIAGRAM..... 3

4. SYSTEM APPLICATION EXAMPLE..... 4

5. PIN EXPLANATION ..... 5

6. ABSOLUTE MAXIMUM RATINGS..... 6

7. RECOMMENDED OPERATING RANGE ..... 6

8. ELECTRICAL CHARACTERISTICS ..... 6

9. OTHER CHARACTERISTICS, FOR REFERENCE PURPOSES ONLY ..... 7

10. APPLICATION CIRCUIT EXAMPLE CHARACTERISTICS FOR REFERENCE PURPOSES ONLY..... 7

11. TEST CIRCUIT ..... 8

    11.1 Test Circuit 1..... 8

    11.2 Test Circuit 2..... 10

    11.3 Application Circuit Example..... 12

12. TYPICAL CHARACTERISTICS..... 14

    12.1 μPC8106TB..... 14

    12.2 μPC8109TB..... 16

13. S-PARAMETERS ..... 18

    13.1 S-parameters for Each Port – μPC8106TB, μPC8109TB in common – ..... 18

    13.2 S-parameters for Matched RF Output – with test circuits 1 and 2 – ..... 19

    13.3 S-parameters for Matched RF Output – with application circuit example –..... 20

14. PACKAGE DIMENSIONS..... 21

15. NOTE ON CORRECT USE..... 22

16. RECOMMENDED SOLDERING CONDITIONS..... 22

1. PIN CONNECTIONS

$\mu$ PC8106TB,  $\mu$ PC8109TB in common

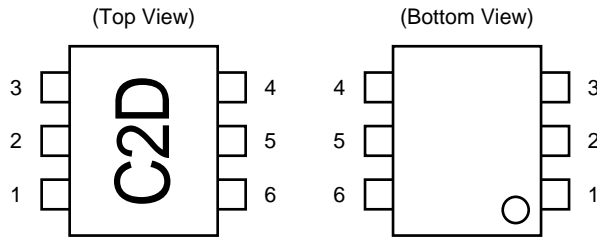

Example marking is for  $\mu$ PC8106TB

Pin No.	Pin Name
1	IFinput
2	GND
3	LOinput
4	PS
5	V <sub>cc</sub>
6	RFoutput

★ 2. PRODUCT LINE-UP (T<sub>A</sub> = +25°C, V<sub>CC</sub> = V<sub>PS</sub> = V<sub>RFout</sub> = 3.0 V, Z<sub>s</sub> = Z<sub>L</sub> = 50 Ω)

Part Number	I <sub>cc</sub> (mA)	f <sub>RFout</sub> (GHz)	CG (dB)		
			@RF 0.9 GHz <sup>Note</sup>	@RF 1.9 GHz	@RF 2.4 GHz
$\mu$ PC8106TB	9	0.4 to 2.0	9	7	–
$\mu$ PC8109TB	5	0.4 to 2.0	6	4	–
$\mu$ PC8163TB	16.5	0.8 to 2.0	9	5.5	–
$\mu$ PC8172TB	9	0.8 to 2.5	9.5	8.5	8.0
$\mu$ PC8187TB	15	0.8 to 2.5	11	11	10

Part Number	P <sub>O(sat)</sub> (dBm)			OIP <sub>3</sub> (dBm)		
	@RF 0.9 GHz <sup>Note</sup>	@RF 1.9 GHz	@RF 2.4 GHz	@RF 0.9 GHz <sup>Note</sup>	@RF 1.9 GHz	@RF 2.4 GHz
$\mu$ PC8106TB	–2	–4	–	+5.5	+2.0	–
$\mu$ PC8109TB	–5.5	–7.5	–	+1.5	–1.0	–
$\mu$ PC8163TB	+0.5	–2	–	+9.5	+6.0	–
$\mu$ PC8172TB	+0.5	0	–0.5	+7.5	+6.0	+4.0
$\mu$ PC8187TB	+4	+2.5	+1	+10	+10	+8.5

**Note** f<sub>RFout</sub> = 0.83 GHz @  $\mu$ PC8163TB and  $\mu$ PC8187TB

**Remark** Typical performance. Please refer to **ELECTRICAL CHARACTERISTICS** in detail.  
To know the associated product, please refer to each latest data sheet.

3. INTERNAL BLOCK DIAGRAM (for the  $\mu$ PC8106TB and  $\mu$ PC8109TB)

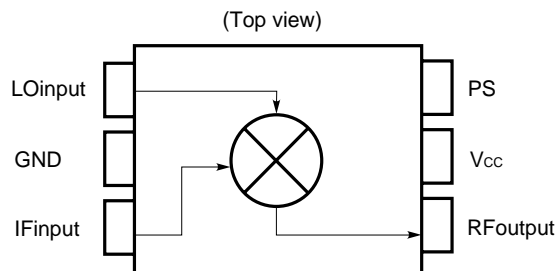

4. SYSTEM APPLICATION EXAMPLE (schematics of IC location in the system)

WIRELESS TRANSCEIVER

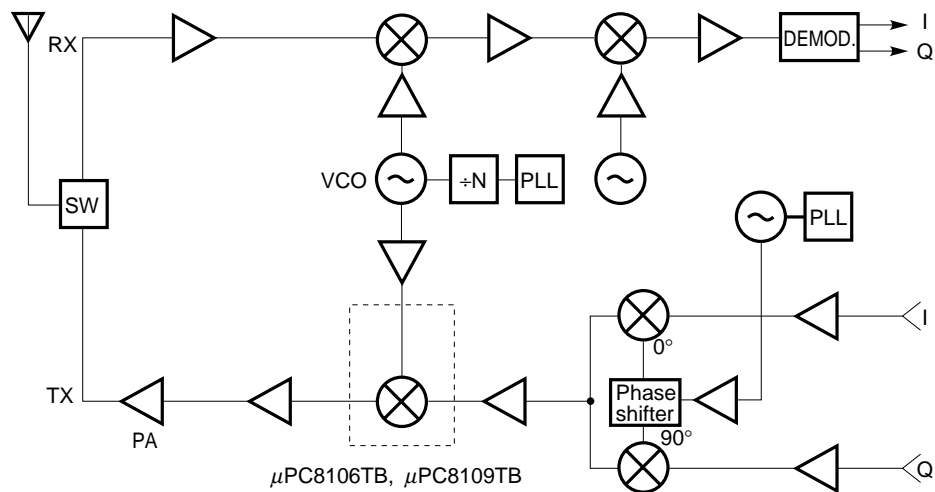

5. PIN EXPLANATION (for the μPC8106TB and μPC8109TB)

Pin No.	Pin Name	Applied Voltage (V)	Pin Voltage (V) <sup>Note</sup>	Function and Explanation	Equivalent Circuit						
1	IFinput	–	1.3	This pin is IF input to double balanced mixer (DBM). The input is designed as high impedance. The circuit contributes to suppress spurious signal. Also this symmetrical circuit can keep specified performance insensitive to process-condition distribution. For above reason, double balanced mixer is adopted.							
2	GND	GND	–	GND pin. Ground pattern on the board should be formed as wide as possible. Track Length should be kept as short as possible to minimize ground impedance.							
3	LOinput	–	2.4	Local input pin. Recommendable input level is –10 to 0 dBm.							
5	V <sub>cc</sub>	2.7 to 5.5	–	Supply voltage pin.							
6	RFoutput	Same bias as V <sub>cc</sub> through external inductor	–	This pin is RF output from DBM. This pin is designed as open collector. Due to the high impedance output, this pin should be externally equipped with LC matching circuit to next stage.							
4	PS	V <sub>cc</sub> or GND	–	Power save control pin. Bias controls operation as follows. <table border="1" style="margin: 10px auto;"> <tr> <td>Pin bias</td> <td>Control</td> </tr> <tr> <td>V<sub>cc</sub></td> <td>Operation</td> </tr> <tr> <td>GND</td> <td>Power Save</td> </tr> </table>	Pin bias	Control	V <sub>cc</sub>	Operation	GND	Power Save	
Pin bias	Control										
V <sub>cc</sub>	Operation										
GND	Power Save										

**Note** Each pin voltage is measured at V<sub>CC</sub> = V<sub>PS</sub> = V<sub>RFout</sub> = 3.0 V.

**6. ABSOLUTE MAXIMUM RATINGS**

Parameter	Symbol	Test Conditions	Rating	Unit
Supply Voltage	V <sub>CC</sub>	T <sub>A</sub> = +25°C, Pin 5 and 6	6.0	V
PS pin Input Voltage	V <sub>PS</sub>	T <sub>A</sub> = +25°C	6.0	V
★ Package Power Dissipation	P <sub>D</sub>	Mounted on double-sided copper-clad 50 × 50 × 1.6 mm epoxy glass PWB T <sub>A</sub> = +85°C	270	mW
Operating Ambient Temperature	T <sub>A</sub>		-40 to +85	°C
Storage Temperature	T <sub>stg</sub>		-55 to +150	°C
Maximum Input Power	P <sub>in</sub>		+10	dBm

**7. RECOMMENDED OPERATING RANGE**

Parameter	Symbol	MIN.	TYP.	MAX.	Unit	Remarks
Supply Voltage	V <sub>CC</sub>	2.7	3.0	5.5	V	The same voltage should be supplied to pin 5 and 6
Operating Ambient Temperature	T <sub>A</sub>	-40	+25	+85	°C	
Local Input Power	P <sub>LOin</sub>	-10	-5	0	dBm	Z <sub>s</sub> = 50 Ω (without matching)
RF Output Frequency	f <sub>RFout</sub>	0.4	-	2.0	GHz	With external matching circuit
IF Input Frequency	f <sub>IFin</sub>	100	-	400	MHz	

**8. ELECTRICAL CHARACTERISTICS**

(T<sub>A</sub> = +25°C, V<sub>CC</sub> = V<sub>RFout</sub> = 3.0 V, f<sub>IFin</sub> = 240 MHz, P<sub>LOin</sub> = -5 dBm, and V<sub>PS</sub> ≥ 2.7 V unless otherwise specified)

Parameter	Symbol	Conditions	$\mu$ PC8106TB			$\mu$ PC8109TB			Unit
			MIN.	TYP.	MAX.	MIN.	TYP.	MAX.	
Circuit Current	I <sub>CC</sub>	No input signal	4.5	9	13.5	2.5	5	8.0	mA
Circuit Current in Power-save Mode	I <sub>CC(PS)</sub>	V <sub>PS</sub> = 0 V	-	-	10	-	-	10	μA
Conversion Gain 1	CG1	f <sub>RFout</sub> = 0.9 GHz, P <sub>IFin</sub> = -30 dBm	6	9	12	3	6	9	dB
Conversion Gain 2	CG2	f <sub>RFout</sub> = 1.9 GHz, P <sub>IFin</sub> = -30 dBm	4	7	10	1	4	7	dB
Saturated Output Power 1	P <sub>O(sat)1</sub>	f <sub>RFout</sub> = 0.9 GHz, P <sub>IFin</sub> = 0 dBm	-4	-2	-	-7.5	-5.5	-	dBm
Saturated Output Power 2	P <sub>O(sat)2</sub>	f <sub>RFout</sub> = 1.9 GHz, P <sub>IFin</sub> = 0 dBm	-6.5	-4	-	-10	-7.5	-	dBm

**9. OTHER CHARACTERISTICS, FOR REFERENCE PURPOSES ONLY**

( $T_A = +25^\circ\text{C}$ ,  $V_{CC} = V_{RFout} = 3.0\text{ V}$ ,  $P_{LOin} = -5\text{ dBm}$ , and  $V_{PS} \geq 2.7\text{ V}$  unless otherwise mentioned)

Parameter	Symbol	Conditions		Reference Value		Unit
				$\mu$ PC8106TB	$\mu$ PC8109TB	
3rd Order Distortion Output Intercept Point	OIP <sub>31</sub>	f <sub>Fin1</sub> = 240.0 MHz	f <sub>RFout</sub> = 0.9 GHz	+5.5	+1.5	dBm
	OIP <sub>32</sub>	f <sub>Fin2</sub> = 240.4 MHz	f <sub>RFout</sub> = 1.9 GHz	+2.0	-1.0	
3rd Order Intermodulation Distortion 1	IM <sub>31</sub>	f <sub>Fin1</sub> = 240.0 MHz f <sub>Fin2</sub> = 240.4 MHz	f <sub>RFout</sub> = 0.9 GHz	-31	-29	dBc
3rd Order Intermodulation Distortion 2	IM <sub>32</sub>	P <sub>IFin</sub> = -20 dBm	f <sub>RFout</sub> = 1.9 GHz	-30	-28	dBc
SSB Noise Figure	SSB • NF	f <sub>RFout</sub> = 0.9 GHz, f <sub>Fin</sub> = 240 MHz		8.5	8.5	dB
Power Save Response Time	Rise time	T <sub>PS(rise)</sub>	V <sub>PS</sub> : GND → V <sub>CC</sub>	2.0	2.0	μs
	Fall time	T <sub>PS(fall)</sub>	V <sub>PS</sub> : V <sub>CC</sub> → GND	2.0	2.0	μs

**10. APPLICATION CIRCUIT EXAMPLE CHARACTERISTICS FOR REFERENCE PURPOSES**

**ONLY** ( $T_A = +25^\circ\text{C}$ ,  $V_{CC} = V_{PS} = V_{RFout} = 3.0\text{ V}$ , f<sub>Fin</sub> = 130 MHz, f<sub>LOin</sub> = 1 630 MHz, P<sub>LOin</sub> = -5 dBm)

Parameter	Symbol	Conditions	Reference Value	Unit
			$\mu$ PC8106TB	
Conversion Gain	CG	f <sub>RFout</sub> = 1.5 GHz, with application circuit example	7	dB
Saturated Output Power	P <sub>O(sat)</sub>	f <sub>RFout</sub> = 1.5 GHz, with application circuit example	-3.5	dBm

11. TEST CIRCUIT

11.1 Test Circuit 1 ( $f_{RFout} = 900$  MHz, for the  $\mu$ PC8106TB and  $\mu$ PC8109TB)

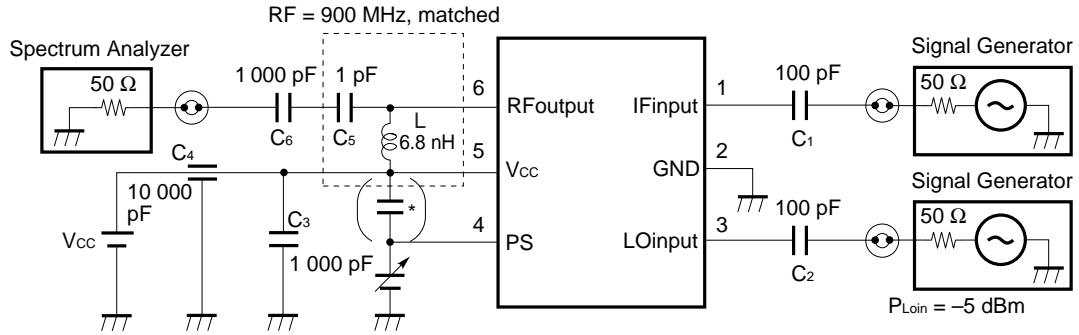

\* In case of unstable operation, please connect capacitor 100 pF between 4 pin and 5 pin and adjust the matching circuit.

EXAMPLE OF TEST CIRCUIT 1 ASSEMBLED ON EVALUATION BOARD

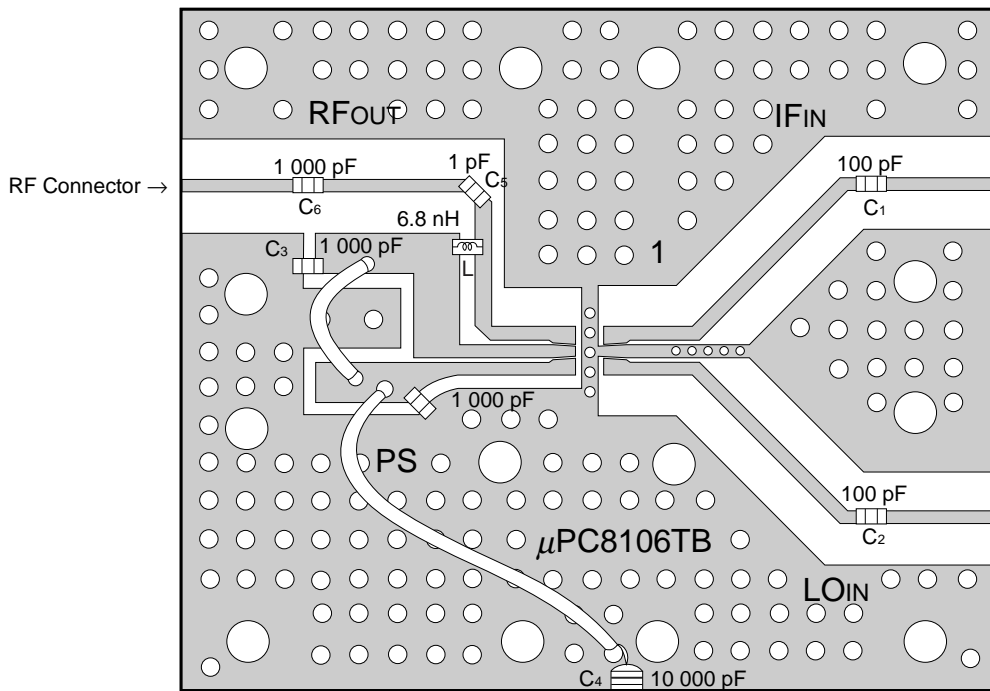

**COMPONENT LIST**

Form	Symbol	Value
Chip capacitor	C <sub>1</sub> , C <sub>2</sub>	100 pF
	C <sub>3</sub> , C <sub>6</sub>	1 000 pF
	C <sub>5</sub>	1 pF
Through capacitor	C <sub>4</sub>	10 000 pF
Chip inductor	L	6.8 nH <sup>Note</sup>

**Note** 6.8 nH: Murata Mfg. Co., Ltd. LQP31A6N8J04

**EVALUATION BOARD CHARACTERS**

- (1) Double-sided copper clad 35 × 42 × 0.4 mm polyimide board
- (2) Back side: GND pattern
- (3) Solder plated patterns
- (4) ○○○: Through holes
- (5) C<sub>6</sub> is for RF short on the board pattern

11.2 Test Circuit 2 (f<sub>RFout</sub> = 1.9 GHz, for the  $\mu$ PC8106TB and  $\mu$ PC8109TB)

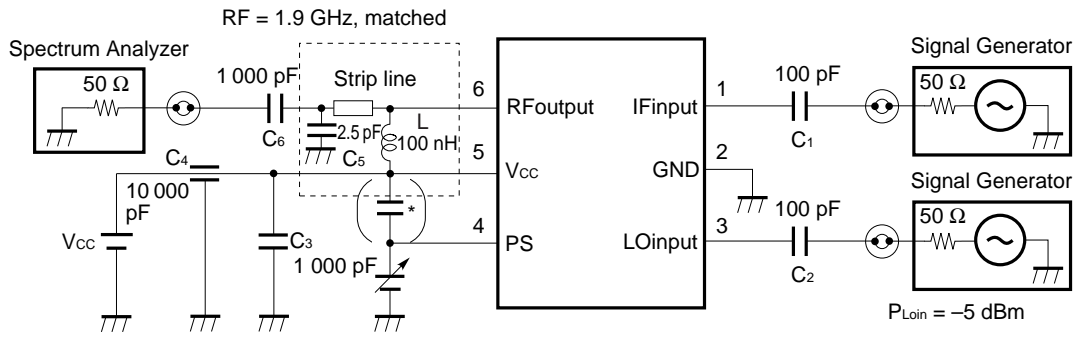

\* In case of unstable operation, please connect capacitor 100 pF between 4 pin and 5 pin and adjust the matching circuit.

★ EXAMPLE OF TEST CIRCUIT 2 ASSEMBLED ON EVALUATION BOARD

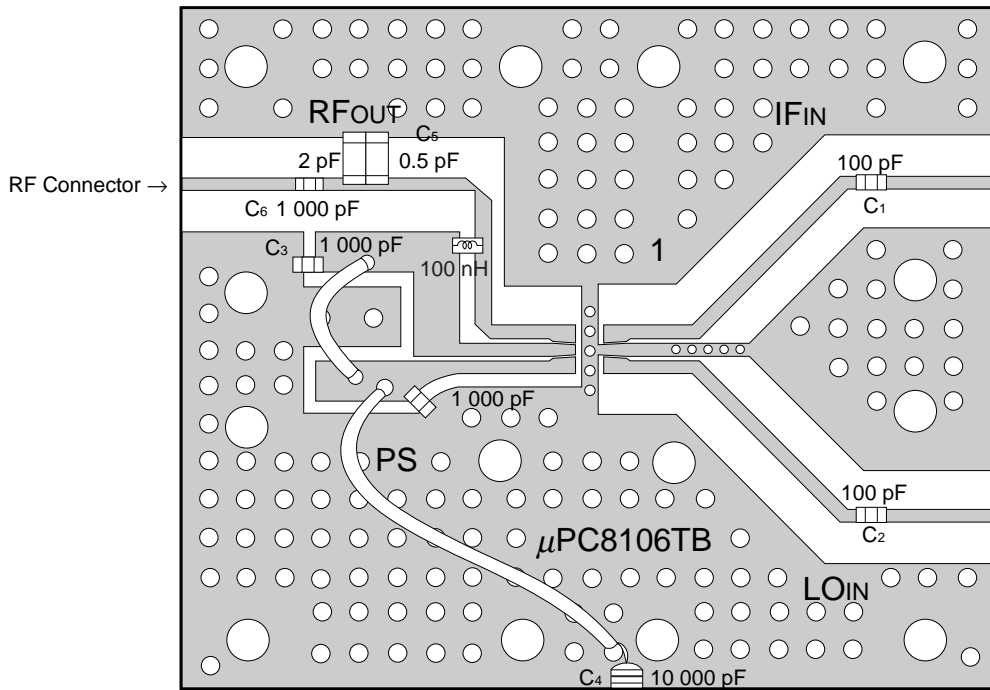

**COMPONENT LIST**

Form	Symbol	Value
Chip capacitor	C <sub>1</sub> , C <sub>2</sub>	100 pF
	C <sub>3</sub> , C <sub>6</sub>	1 000 pF
	C <sub>5</sub>	2.5 pF (2.0 pF, 0.5 pF parallel)
Through capacitor	C <sub>4</sub>	10 000 pF
Chip inductor	L	100 nH <sup>Note</sup>

**Note** 100 nH: Murata Mfg. Co., Ltd. LQN1AR10J(K)04

**EVALUATION BOARD CHARACTERS**

- (1) Double-sided copper clad 35 × 42 × 0.4 mm polyimide board
- (2) Back side: GND pattern
- (3) Solder plated patterns
- (4) ○○○: Through holes

11.3 Application Circuit Example (f<sub>RFout</sub> = 1.5 GHz, for the  $\mu$ PC8106TB and  $\mu$ PC8109TB)

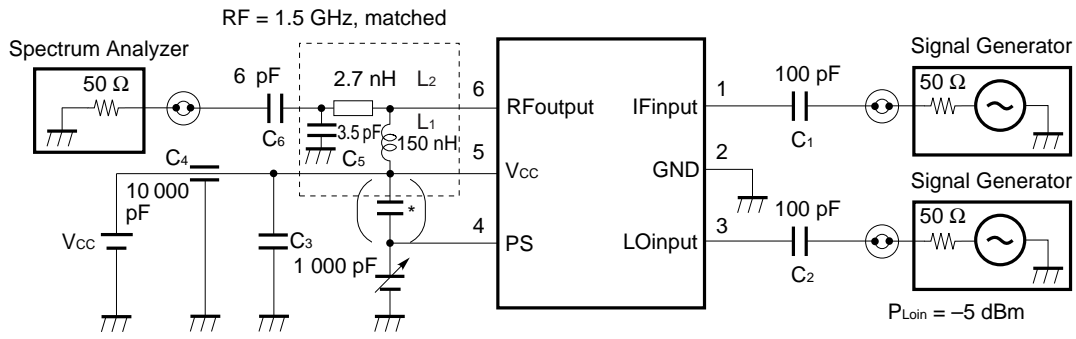

\* In case of unstable operation, please connect capacitor 100 pF between 4 pin and 5 pin and adjust the matching circuit.

EXAMPLE OF APPLICATION CIRCUIT ASSEMBLED ON EVALUATION BOARD

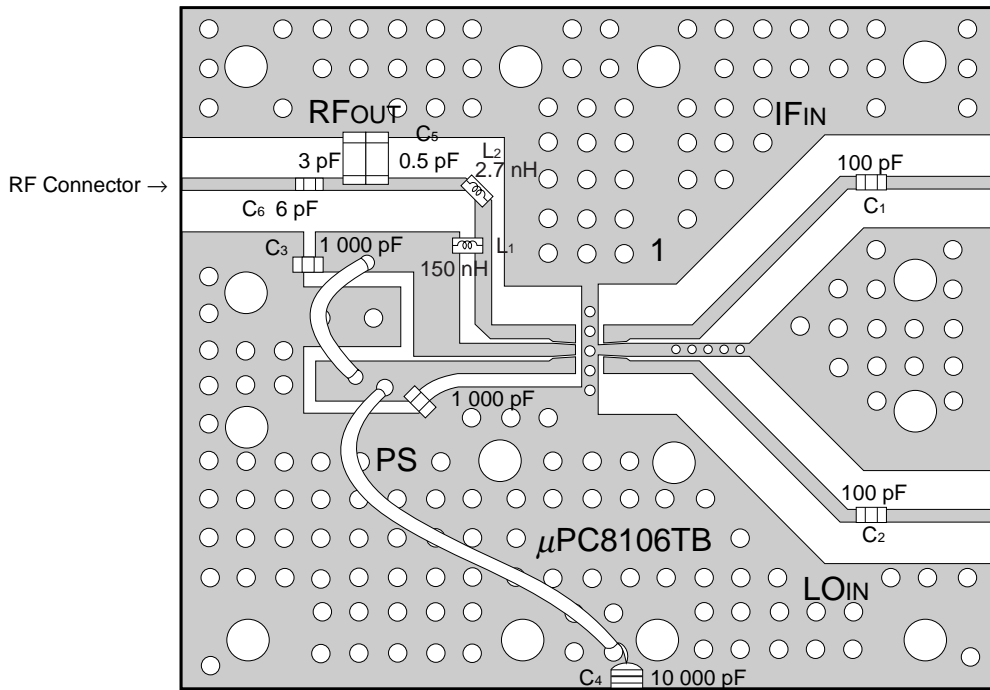

**COMPONENT LIST**

Form	Symbol	Value
Chip capacitor	C <sub>1</sub> , C <sub>2</sub>	100 pF
	C <sub>3</sub>	1 000 pF
	C <sub>5</sub>	3.5 pF (3.0 pF, 0.5 pF parallel)
	C <sub>6</sub>	6 pF
Through capacitor	C <sub>4</sub>	10 000 pF
Chip inductor	L <sub>1</sub>	150 nH <sup>Note 1</sup>
	L <sub>2</sub>	2.7 nH <sup>Note 2</sup>

- Notes**
1. 150 nH: TOKO Co., Ltd. LL2012-FR15
  2. 2.7 nH : TOKO Co., Ltd. LL2012-F2N7S

**EVALUATION BOARD CHARACTERS**

- (1) Double-sided copper clad 35 × 42 × 0.4 mm polyimide board
- (2) Back side: GND pattern
- (3) Solder plated patterns
- (4) ○○○ : Through holes

**Caution**

The test circuits and board pattern on data sheet are for performance evaluation use only. (They are not recommended circuits.) In the case of actual design-in, matching circuit should be determined using S parameter of desired frequency in accordance to actual mounting pattern.

For external circuits of the ICs, following Application Note is also available.

- μPC8106, μPC8109, μPC8163 Application Note (Document No. P13683E)

**12. TYPICAL CHARACTERISTICS ( $T_A = +25^\circ\text{C}$ ,  $V_{CC} = V_{RFout}$ , with test circuit 1 or 2, according to the operating frequency, unless otherwise specified)**

**12.1  $\mu$ PC8106TB**

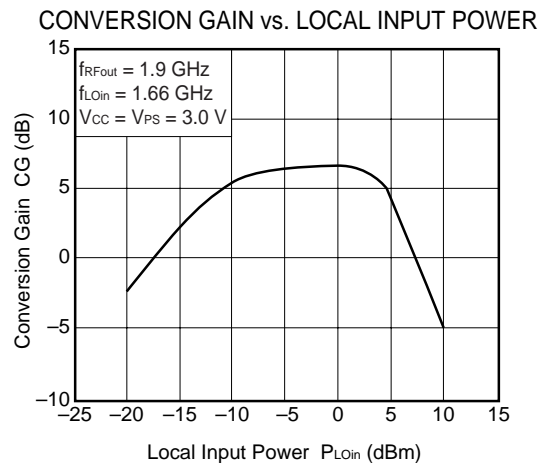
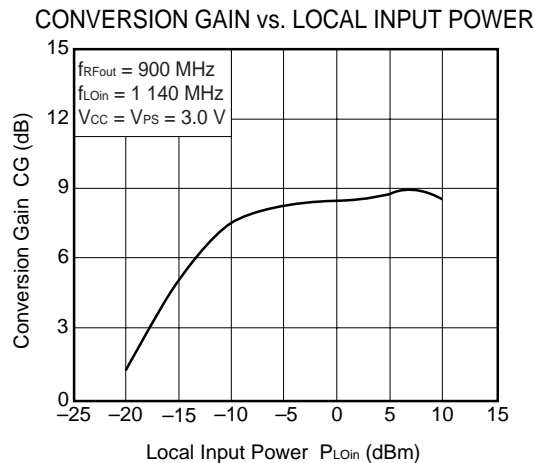
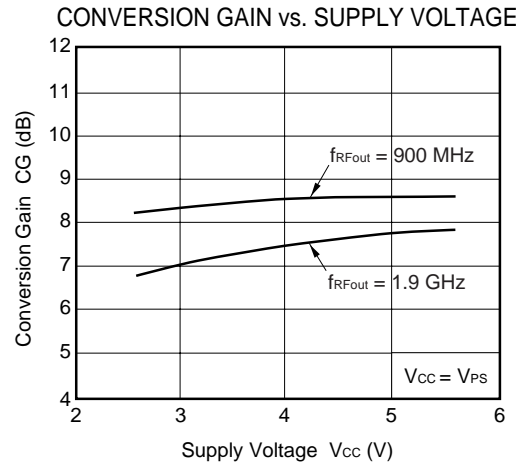
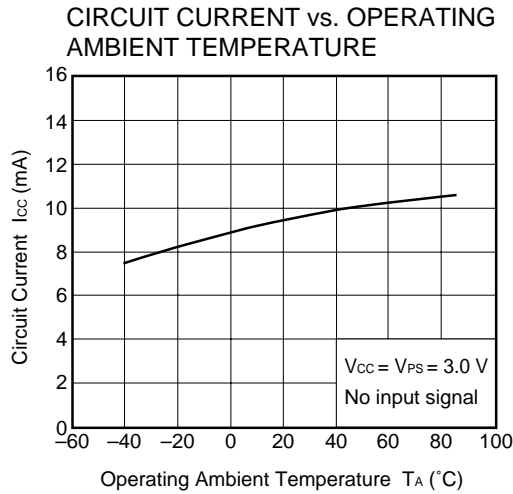
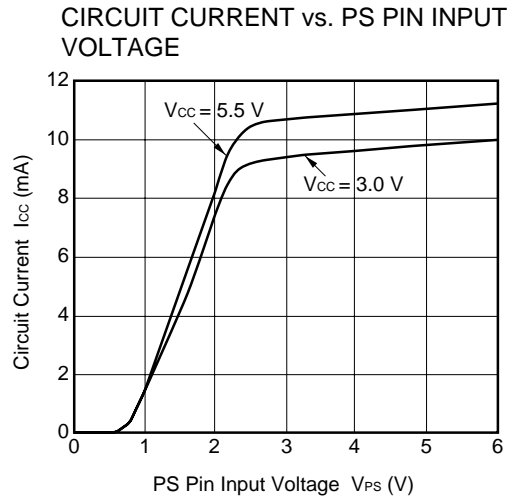
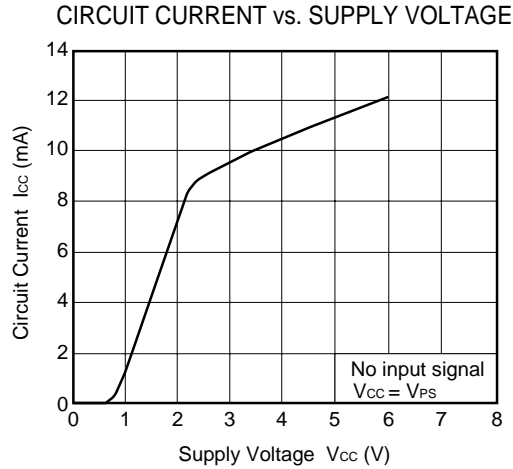

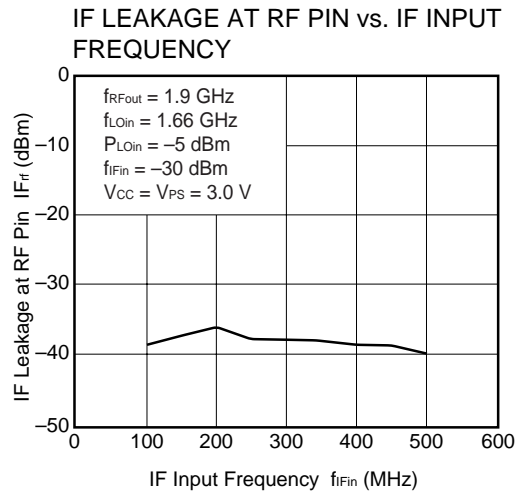
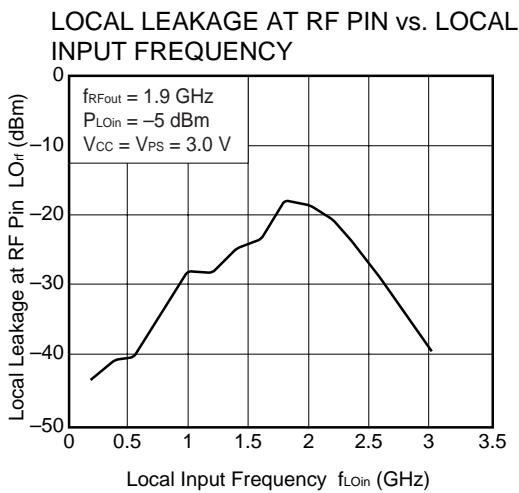
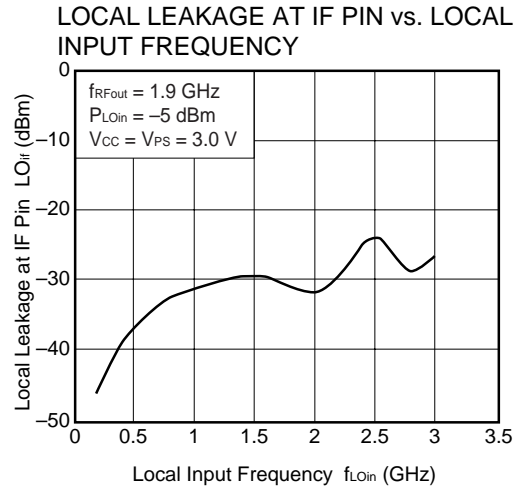
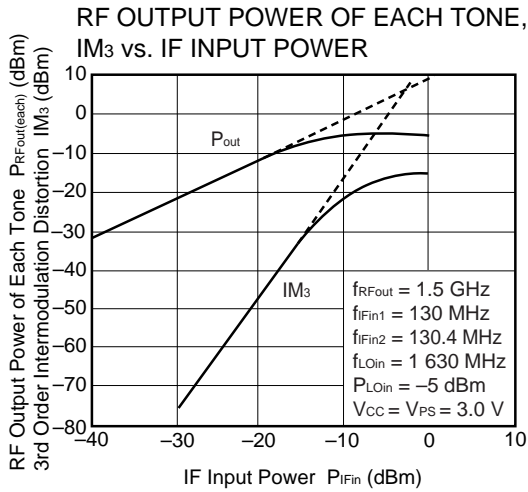
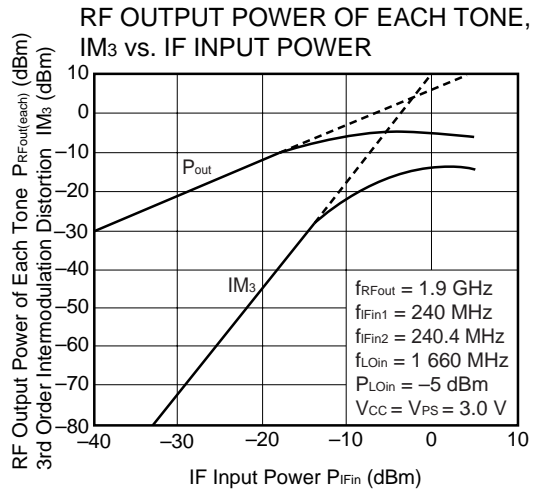
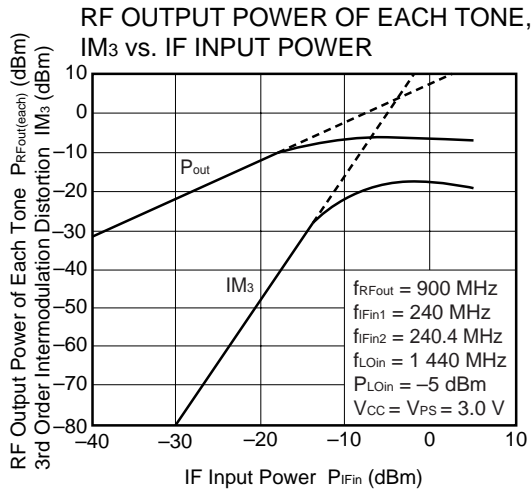

12.2  $\mu$ PC8109TB

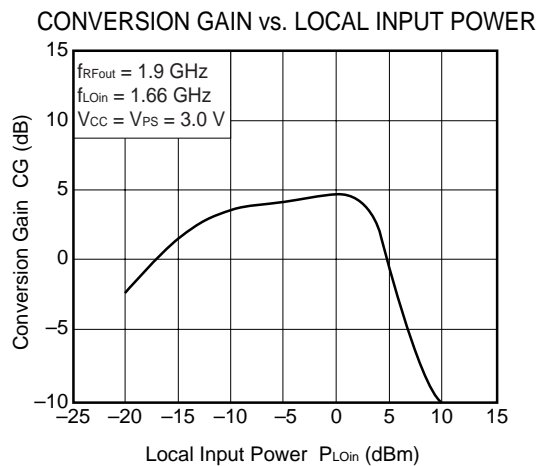
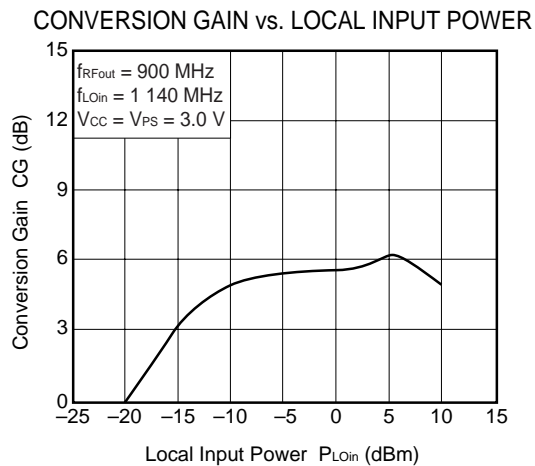
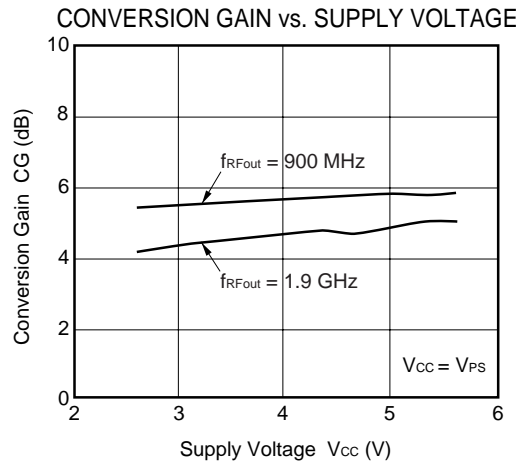
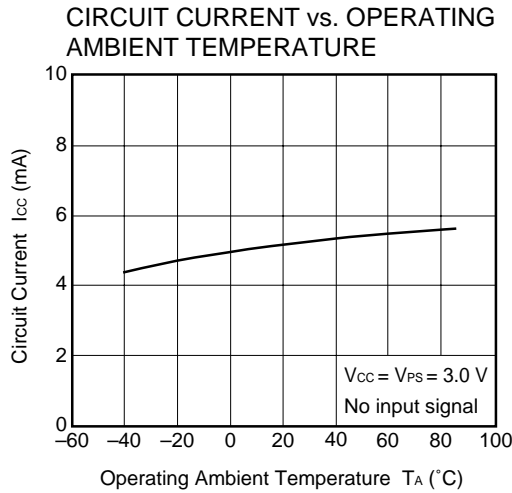
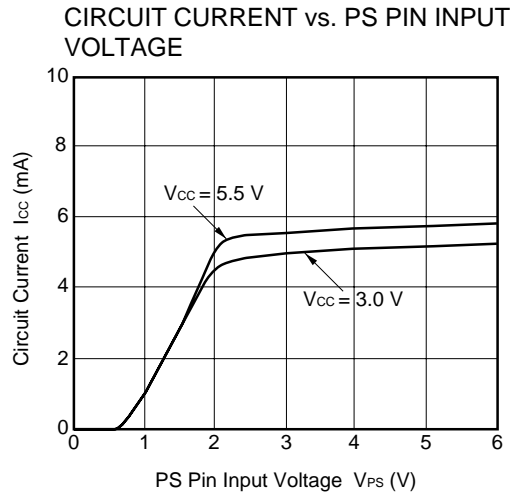
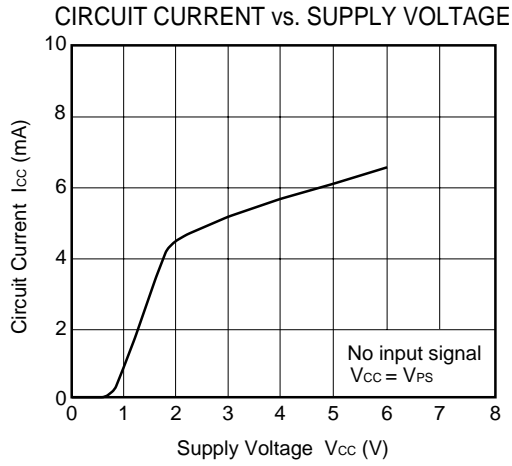

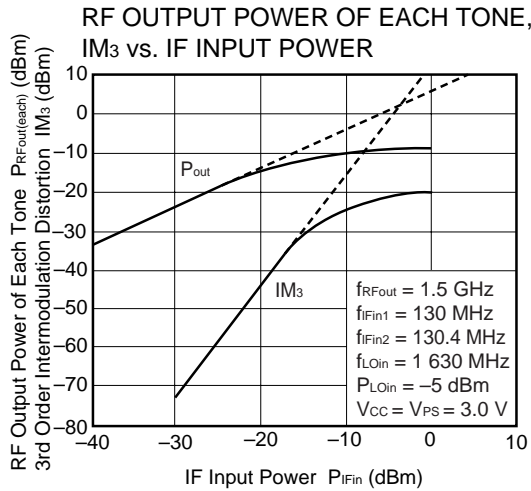
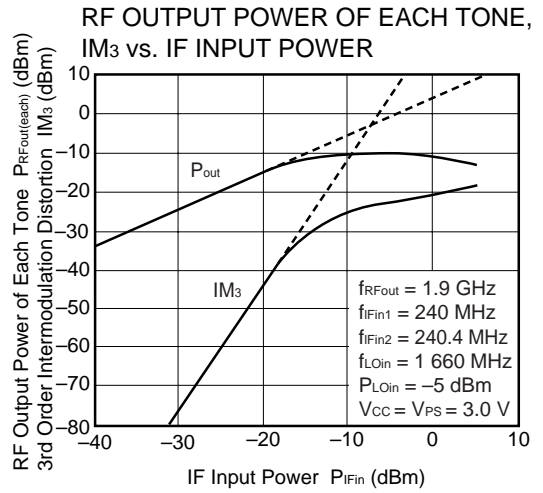
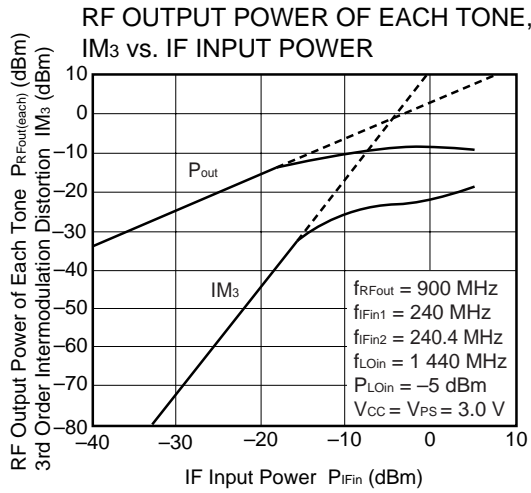

**Remark** The graphs indicate nominal characteristics.

13. S-PARAMETERS

13.1 S-parameters for Each Port ( $V_{CC} = V_{PS} = V_{RFout} = 3.0\text{ V}$ ) –  $\mu$ PC8106TB,  $\mu$ PC8109TB in common – (the parameters are monitored at DUT pins.)

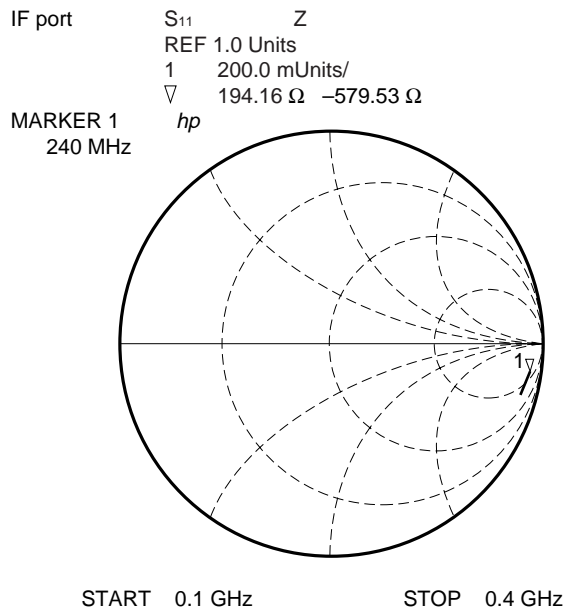
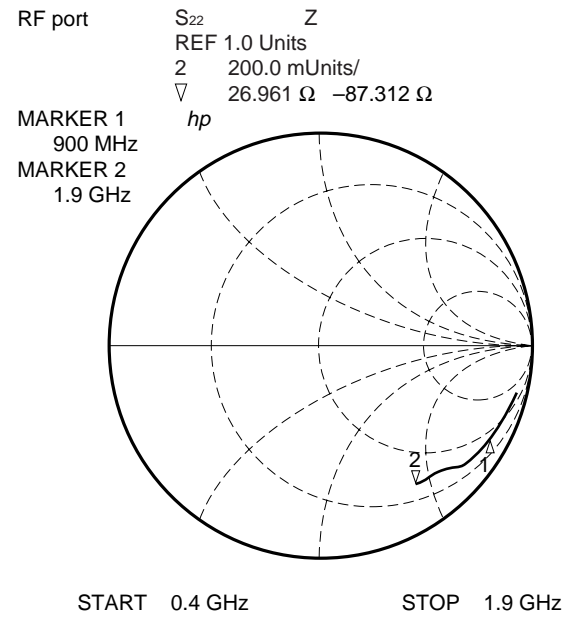
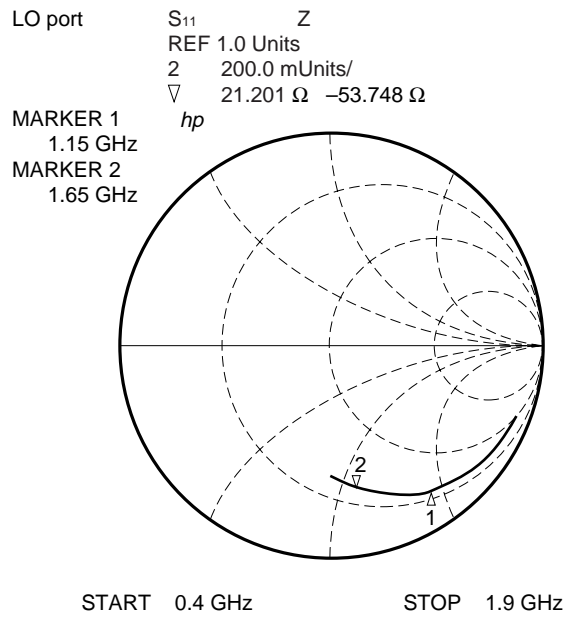

**13.2 S-parameters for Matched RF Output ( $V_{CC} = V_{PS} = V_{RFout} = 3.0\text{ V}$ ) – with test circuits 1 and 2 ( $\mu$ PC8106TB,  $\mu$ PC8109TB in common) – ( $S_{22}$  data are monitored at RF connector on board.)**

900 MHz (LC-matched) in test circuit 1  
 $S_{22}$  log MAG

REF 0.0 dB  
 1 10.0 dB/  
 $\nabla$  -19.567 dB

hp

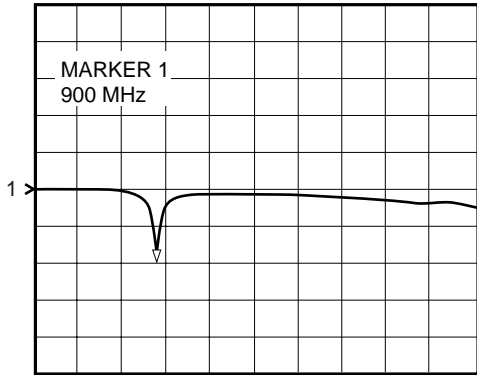

START 100 MHz STOP 3 000 MHz

1.9 GHz (matched) in test circuit 2  
 $S_{22}$  log MAG

REF 0.0 dB  
 1 10.0 dB/  
 $\nabla$  -15.213 dB

hp

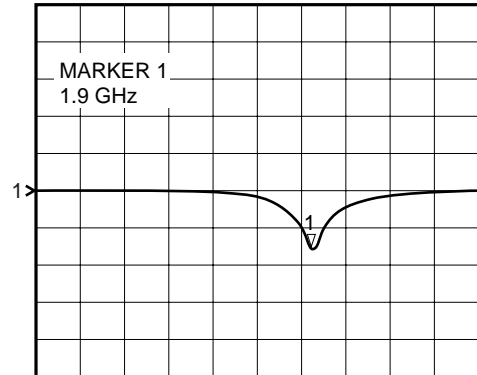

START 100 MHz STOP 3 000 MHz

$S_{22}$   
 REF 1.0 Units  
 1 200.0 mUnits/  
 $\nabla$  36.59  $\Omega$  2.9355  $\Omega$

hp

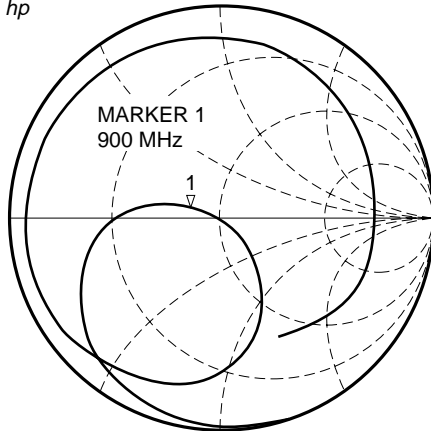

START 100 MHz STOP 3 000 MHz

$S_{22}$   
 REF 1.0 Units  
 1 200.0 mUnits/  
 $\nabla$  58.191  $\Omega$  -4.1191  $\Omega$

hp

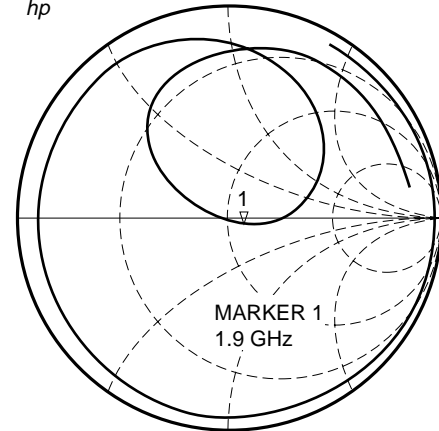

START 100 MHz STOP 3 000 MHz

**13.3 S-parameters for Matched RF Output ( $V_{CC} = V_{PS} = V_{RFout} = 3.0\text{ V}$ ) – with application circuit example – ( $S_{22}$  data are monitored at RF connector on board.)**

1.5 GHz (matched) in application circuit example  
 $S_{22}$  log MAG  
 REF 0.0 dB  
 1 10.0 dB/  
 $\nabla$  -20.901 dB  
 hp

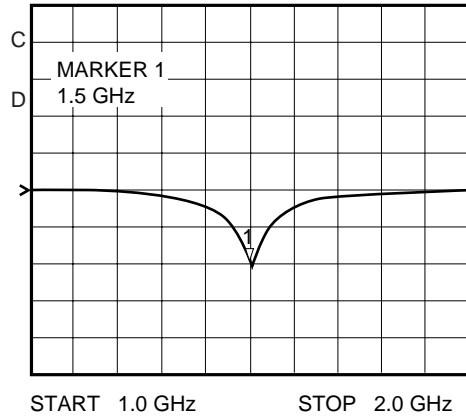

$S_{22}$  Z  
 REF 1.0 Units  
 1 200.0 mUnits/  
 $\nabla$  59.086  $\Omega$  -3.873  $\Omega$   
 hp

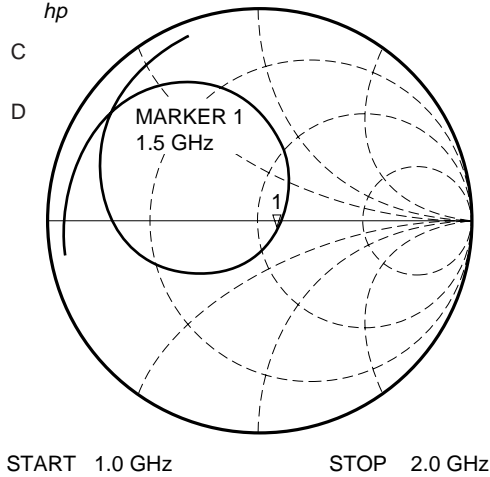

★ 14. PACKAGE DIMENSIONS

6-PIN SUPER MINIMOLD (UNIT: mm)

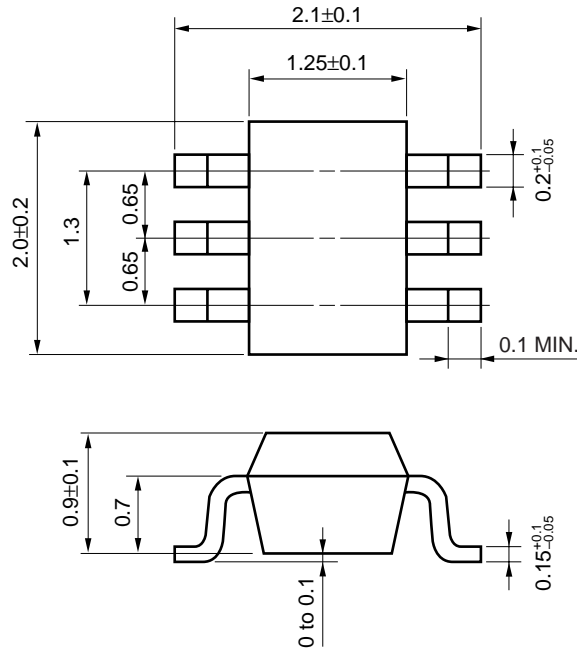

**15. NOTE ON CORRECT USE**

- (1) Observe precautions for handling because of electrostatic sensitive devices.
- (2) Form a ground pattern as widely as possible to minimize ground impedance (to prevent undesired oscillation).
- (3) Keep the wiring length of the ground pins as short as possible.
- (4) Connect a bypass capacitor to the V<sub>cc</sub> pin.
- (5) Connect a matching circuit to the RF output pin.

**16. RECOMMENDED SOLDERING CONDITIONS**

This product should be soldered under the following recommended conditions. For soldering methods and conditions other than those recommended below, contact your NEC sales representative.

Soldering Method	Soldering Conditions	Recommended Condition Symbol
Infrared Reflow	Package peak temperature: 235°C or below Time: 30 seconds or less (at 210°C) Count: 3, Exposure limit: None <sup>Note</sup>	IR35-00-3
VPS	Package peak temperature: 215°C or below Time: 40 seconds or less (at 200°C) Count: 3, Exposure limit: None <sup>Note</sup>	VP15-00-3
Wave Soldering	Soldering bath temperature: 260°C or below Time: 10 seconds or less Count: 1, Exposure limit: None <sup>Note</sup>	WS60-00-1
Partial Heating	Pin temperature: 300°C Time: 3 seconds or less (per side of device) Exposure limit: None <sup>Note</sup>	—

**Note** After opening the dry pack, keep it in a place below 25°C and 65% RH for the allowable storage period.

**Caution** Do not use different soldering methods together (except for partial heating).

For details of recommended soldering conditions for surface mounting, refer to information document SEMICONDUCTOR DEVICE MOUNTING TECHNOLOGY MANUAL (C10535E).

[MEMO]

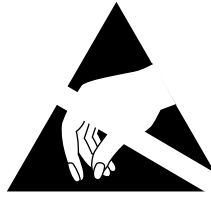

## ATTENTION

OBSERVE PRECAUTIONS  
FOR HANDLING  
ELECTROSTATIC  
SENSITIVE  
DEVICES

NESAT (NEC Silicon Advanced Technology) is a trademark of NEC Corporation.

- **The information in this document is current as of November, 2000. The information is subject to change without notice. For actual design-in, refer to the latest publications of NEC's data sheets or data books, etc., for the most up-to-date specifications of NEC semiconductor products. Not all products and/or types are available in every country. Please check with an NEC sales representative for availability and additional information.**
  - No part of this document may be copied or reproduced in any form or by any means without prior written consent of NEC. NEC assumes no responsibility for any errors that may appear in this document.
  - NEC does not assume any liability for infringement of patents, copyrights or other intellectual property rights of third parties by or arising from the use of NEC semiconductor products listed in this document or any other liability arising from the use of such products. No license, express, implied or otherwise, is granted under any patents, copyrights or other intellectual property rights of NEC or others.
  - Descriptions of circuits, software and other related information in this document are provided for illustrative purposes in semiconductor product operation and application examples. The incorporation of these circuits, software and information in the design of customer's equipment shall be done under the full responsibility of customer. NEC assumes no responsibility for any losses incurred by customers or third parties arising from the use of these circuits, software and information.
  - While NEC endeavours to enhance the quality, reliability and safety of NEC semiconductor products, customers agree and acknowledge that the possibility of defects thereof cannot be eliminated entirely. To minimize risks of damage to property or injury (including death) to persons arising from defects in NEC semiconductor products, customers must incorporate sufficient safety measures in their design, such as redundancy, fire-containment, and anti-failure features.
  - NEC semiconductor products are classified into the following three quality grades:  
 "Standard", "Special" and "Specific". The "Specific" quality grade applies only to semiconductor products developed based on a customer-designated "quality assurance program" for a specific application. The recommended applications of a semiconductor product depend on its quality grade, as indicated below. Customers must check the quality grade of each semiconductor product before using it in a particular application.
    - "Standard": Computers, office equipment, communications equipment, test and measurement equipment, audio and visual equipment, home electronic appliances, machine tools, personal electronic equipment and industrial robots
    - "Special": Transportation equipment (automobiles, trains, ships, etc.), traffic control systems, anti-disaster systems, anti-crime systems, safety equipment and medical equipment (not specifically designed for life support)
    - "Specific": Aircraft, aerospace equipment, submersible repeaters, nuclear reactor control systems, life support systems and medical equipment for life support, etc.
- The quality grade of NEC semiconductor products is "Standard" unless otherwise expressly specified in NEC's data sheets or data books, etc. If customers wish to use NEC semiconductor products in applications not intended by NEC, they must contact an NEC sales representative in advance to determine NEC's willingness to support a given application.
- (Note)
- (1) "NEC" as used in this statement means NEC Corporation and also includes its majority-owned subsidiaries.
  - (2) "NEC semiconductor products" means any semiconductor product developed or manufactured by or for NEC (as defined above).