

FEATURES

- 14-bit resolution
- 6.4MHz sampling rate
- Functionally complete
- No missing codes over full military temperature range
- Edge-triggered, 1.7 Watts
- Small, 28-pin, ceramic DDIP
- Ideal for both time and frequency-domain applications



GENERAL DESCRIPTION

The low-cost ADS-30639 is a dual 14-bit, 6.4MHz sampling A/D converter. This device accurately samples full-scale input signals up to Nyquist frequencies with no missing codes. The dynamic performance of the ADS-30639 has been optimized to achieve a signal-to-noise ratio (SNR) of 78dB and a total harmonic distortion (THD) of -80dB. Each channel is completely independent allowing operation with independent analog inputs and start convert signals.

Packaged in a miniature 28-pin DDIP, the functionally complete ADS-30639 contains two individual fast-settling sample-and-hold amplifiers and subranging A/D converters, along with an internal reference, timing/control logic, and error-correction circuitry. Digital input and output levels are TTL. The ADS-30639 only requires the rising edge of the start convert pulse to operate.

Requiring only $\pm 5V$ and +15V supplies, the ADS-30639 dissipates 1.7 Watts. The device is offered with a bipolar ($\pm 2.0V$) analog input range. Model is available for use in -55 to +125°C operating temperature range. A proprietary, auto-

INPUT/OUTPUT CONNECTIONS

PIN	FUNCTION	PIN	FUNCTION
1	INPUT "A"	28	INPUT "B"
2	RANGE	27	-5V
3	+2.5V REFERENCE	26	+15V
4	ANALOG GROUND	25	+5V
5	+5VA	24	DIGITAL GROUND
6	START CONVERT "A"	23	START CONVERT "B"
7	SELECT	22	ENABLE
8	BIT 14 (LSB)	21	BIT 1 (MSB)
9	BIT 13	20	BIT 2
10	BIT 12	19	BIT 3
11	BIT 11	18	BIT 4
12	BIT 10	17	BIT 5
13	BIT 9	16	BIT 6
14	BIT 8	15	BIT 7

calibrating, error-correcting circuit enables the device to achieve specified performance over the full military temperature range. Typical applications include medical imaging, radar, sonar, communications and instrumentation.

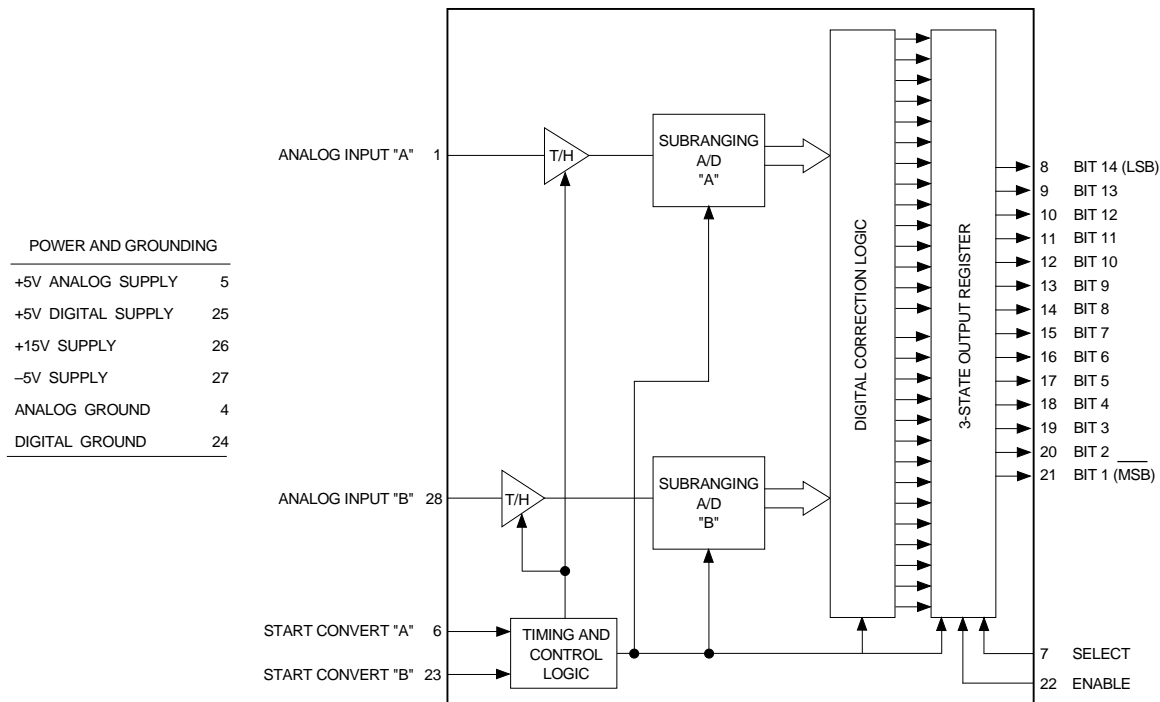

Figure 1. ADS-30639 Functional Block Diagram

ABSOLUTE MAXIMUM RATINGS

PARAMETERS	LIMITS	UNITS
+5V Supply (Pins 5, 25)	0 to +6	Volts
+15V Supply (Pin 26)	12 to 17	Volts
-5V Supply (Pin 27)	0 to -6	Volts
Digital Inputs (Pins 6, 7, 22, 23)	-0.3 to +VDD +0.3	Volts
Analog Input (Pins 1, 28)	±5	Volts
Lead Temperature (10 seconds)	+300	°C

PHYSICAL/ENVIRONMENTAL

PARAMETERS	MIN.	TYP.	MAX.	UNITS
Operating Temp. Range, Case ADS-30639	-55	—	+125	°C
Thermal Impedance				
θ_{jc}	—	6	—	°C/Watt
θ_{ca}	—	23	—	°C/Watt
Storage Temperature Range	-65	—	+150	°C
Package Type	28-pin, metal-sealed, ceramic DDIP			
Weight				

FUNCTIONAL SPECIFICATIONS

(TA = +25°C, +VDD = +5V, -VDD = -5V, +VCC = +15V, 6.4MHz sampling rate, ±2V input range, and a minimum 3 minute warmup , unless otherwise specified.)

ANALOG INPUT	+25°C			0 to +70°C			-55 to +125°C			UNITS
	MIN.	TYP.	MAX.	MIN.	TYP.	MAX.	MIN.	TYP.	MAX.	
Bipolar Input Voltage Range	—	±2	—	—	±2	—	—	±2	—	Volts
Input Resistance (Vin A), (Vin B)	380	400	420	380	400	420	380	400	420	Ω
Input Capacitance	—	6	15	—	6	15	—	6	15	pF
DIGITAL INPUT										
Logic Levels										
Logic "1"	+2.0	—	—	+2.0	—	—	+2.0	—	—	Volts
Logic "0"	—	—	+0.8	—	—	+0.8	—	—	+0.8	Volts
Logic Loading "1"	—	—	+20	—	—	+20	—	—	+20	µA
Logic Loading "0"	—	—	-20	—	—	-20	—	—	-20	µA
Start Convert Positive Pulse Width	—	50	—	—	50	—	—	50	—	ns
Input Capacitance CIN	—	10	15	—	10	15	—	10	15	pf
STATIC PERFORMANCE										
Resolution	—	14	—	—	14	—	—	14	—	Bits
Integral Nonlinearity (DC Input)	—	±1	—	—	±2	—	—	±3	—	LSB
Differential Nonlinearity (fin = 10kHz)	-0.90	±0.5	—	-0.90	±0.5	+1	-0.99	±0.5	+1.25	LSB
Full Scale Absolute Accuracy	—	±0.1	±0.3	—	±0.15	±0.5	—	±0.5	±0.8	%FSR
Bipolar Zero Error (Tech Note 2)	—	±0.3	±0.5	—	±0.3	±0.5	—	±0.5	±0.9	%FSR
Gain Error (Tech Note 2)	—	±0.3	±0.5	—	±0.3	±0.5	—	±0.5	±0.9	%FSR
No Missing Codes (fin = 10kHz)	14	—	—	14	—	—	14	—	—	Bits
DYNAMIC PERFORMANCE										
Peak Harmonics (-0.5dB)										
dc to 975kHz	—	-80	-78	—	-80	-78	—	-80	-76	dB
975kHz to 2.4MHz	—	-76	-70	—	-76	-70	—	-76	-68	dB
Total Harmonic Distortion (-0.5dB)										
dc to 975kHz	—	-80	-77	—	-80	-77	—	-80	-74	dB
975kHz to 2.4MHz	—	-75	-69	—	-75	-69	—	-75	-67	dB
Signal-to-Noise Ratio (w/o distortion, -0.5dB)										
dc to 975kHz	76	78	—	76	78	—	75	77	—	dB
975kHz to 2.4MHz	75	77	—	75	77	—	74	76	—	dB
Signal-to-Noise Ratio (& distortion, -0.5dB)										
dc to 975kHz	74	74	—	74	74	—	73	73	—	dB
975kHz to 2.4MHz	68	72	—	68	72	—	67	72	—	dB
Noise	—	150	—	—	150	—	—	150	—	µVrms
Two-tone Intermodulation										
Distortion (fin = 240kHz, 200kHz fs = 6.4MHz, -0.5dB)	—	-76	-70	—	-76	-70	—	-76	-70	dB
Input Bandwidth (-3dB)										
Small Signal (-20dB input)	—	30	—	—	30	—	—	30	—	MHz
Large Signal (-0.5dB input)	—	20	—	—	20	—	—	20	—	MHz
Feedthrough Rejection (fin = 500kHz)	—	78	—	—	78	—	—	78	—	dB
Slew Rate	—	±450	—	—	±450	—	—	±450	—	V/µs
Aperture Delay Time	—	+1	—	—	+1	—	—	+1	—	ns
Aperture Uncertainty	—	5	—	—	5	—	—	5	—	ps rms

DYNAMIC PERFORMANCE (Cont.)	+25°C			0 to +70°C			-55 to +125°C			UNITS
	MIN.	TYP.	MAX.	MIN.	TYP.	MAX.	MIN.	TYP.	MAX.	
S/H Acquisition Time (to ±0.003%FSR, 5V step)	—	45	—	—	45	—	—	45	—	ns
Overvoltage Recovery Time	—	175	—	—	175	—	—	175	—	ns
A/D Conversion Rate	6.4	—	—	6.4	—	—	6.4	—	—	MHz
DIGITAL OUTPUTS										
Logic Levels										
Logic "1"	+2.4	—	Vcc	+2.4	—	Vcc	+2.4	—	Vcc	Volts
Logic "0"	GND	—	+0.4	GND	—	+0.4	GND	—	+0.4	Volts
Logic Loading "1"	—	—	-4	—	—	-4	—	—	-4	mA
Logic Loading "0"	—	—	+4	—	—	+4	—	—	+4	mA
Output Coding	Two's Complement									
Output Capacitance Cout	—	—	15	—	—	15	—	—	15	pf
Tri-State Output Leakage Current Ioz	—	—	±20	—	—	±20	—	—	±20	µA
POWER REQUIREMENTS										
Power Supply Ranges										
+5V Supply	+4.9	+5.0	+5.25	+4.9	+5.0	+5.25	+4.9	+5.0	+5.25	Volts
-5V Supply	-4.5	-5.0	-5.5	-4.5	-5.0	-5.5	-4.5	-5.0	-5.5	Volts
+15V Supply	+13.5	+15	+16.5	+13.5	+15	+16.5	+13.5	+15	+16.5	Volts
Power Supply Currents										
+5V Supply	—	220	270	—	220	270	—	220	270	mA
-5V Supply	—	25	35	—	25	35	—	25	35	mA
+15V Supply	—	20	35	—	20	35	—	20	35	mA
Power Dissipation	—	1.7	1.9	—	1.7	1.9	—	1.7	1.9	Watts
Power Supply Rejection	—	—	±0.05	—	—	±0.05	—	—	±0.05	%FSR/%V
Footnotes:										
<p>All power supplies should be on before applying a start convert pulse. All supplies and the clock (start convert pulses) must be present during warmup periods. The device must be continuously converting during this time.</p> <p>During the 3-minute warm up period there is a slight offset and gain drift but the dynamic specifications of the ADS-30639 are not affected.</p> <p>Contact DATEL for other input voltage ranges.</p> <p>A 50% duty cycle start convert pulse is used for all production testing. For applications requiring less than an 6.4MHz sampling rate, wider start convert pulses can be used. A 50% duty cycle is recommended for all sampling frequencies.</p>						<p>Effective bits is equal to:</p> $\frac{(\text{SNR} + \text{Distortion}) - 1.76 + \left[20 \log \frac{\text{Full Scale Amplitude}}{\text{Actual Input Amplitude}} \right]}{6.02}$ <p>+5 VA and 5 VD supplies are connected internally.</p>				

TECHNICAL NOTES

1. Obtaining fully specified performance from the ADS-30639 requires careful attention to pc card layout and power supply decoupling. The device's analog and digital ground systems are connected to each other internally. For optimal performance, tie all ground pins (4 and 24) directly to a large **analog** ground plane beneath the package.

Bypass all power supplies to ground with 4.7 F tantalum capacitors in parallel with 0.1 F ceramic capacitors. Locate the bypass capacitors as close to the unit as possible.

- 2. The ADS-30639 achieves its specified accuracies without the need for external calibration. It is recommended that the +5VA and +5VD supplies should be powered up from the same source.
- 3. A passive bandpass filter is used at the input of the A/D for all production testing.

THERMAL REQUIREMENTS

All DATEL sampling A/D converters are fully characterized and specified over operating temperature (case) range of -55 to +125°C. All room temperature (T_A = +25°C) production testing is performed without the use of heat sinks or forced air cooling. Thermal impedance figures for each device are listed in their respective specification tables.

These devices do not normally require heat sinks, however, standard precautionary design and layout procedures should be used to ensure devices do not overheat. The ground and power planes beneath the package, as well as all pcb signal runs to and from the device, should be as heavy as possible to help conduct heat away from the package.

Electrically-insulating, thermally-conductive "pads" may be installed underneath the package. Devices should be soldered to boards rather than socketed, and of course, minimal air flow over the surface can greatly help reduce the package temperature.

In more severe ambient conditions, the package/junction temperature of a given device can be reduced dramatically (typically 35%) by using one of DATEL's HS Series heat sinks.

See Ordering Information for the assigned part number. See page 1-183 of the DATEL Data Acquisition Components Catalog for more information on the HS Series. Request DATEL Application Note AN8, "Heat Sinks for DIP Data Converters", or contact DATEL directly, for additional information.

Table 1. Output Coding

MSB	LSB	INPUT VOLT. ±V	BIPOLAR SCALE
01 1111 1111 1111		+1.99976	+FS - 1LSB
01 1000 0000 0000		+1.50000	+3/4FS
01 0000 0000 0000		+1.00000	+1/2FS
00 0000 0000 0000		0.00000	0
11 0000 0000 0000		-1.00000	-1/2FS
10 1000 0000 0000		-1.50000	-3/4FS
10 0000 0000 0001		-1.99976	-FS+1LSB
10 0000 0000 0000		-2.00000	-FS
TWO'S COMP			

Original Specification

V _{DD} = +5V, C _L =60pF		Min(ns)	Max(ns)	Typ(ns)
T _{pwh}	Minimum convert pulse width high	45	—	80
T _{pwl}	Minimum convert pulse width low	45	—	80
T _{nctdv}	New conversion to internal data valid (Internal)	8	20	12
T _{oetdv}	Output enable to data valid	20	40	30
T _{seltdv}	Select change to data valid	20	40	25
T _{dctdv}	Internal data to data valid (Internal)	8	18	12
T _{odtdz}	Output disable to high-impedence	30	45	35
T _{ctdv}	Conversion to data valid	16	38	24

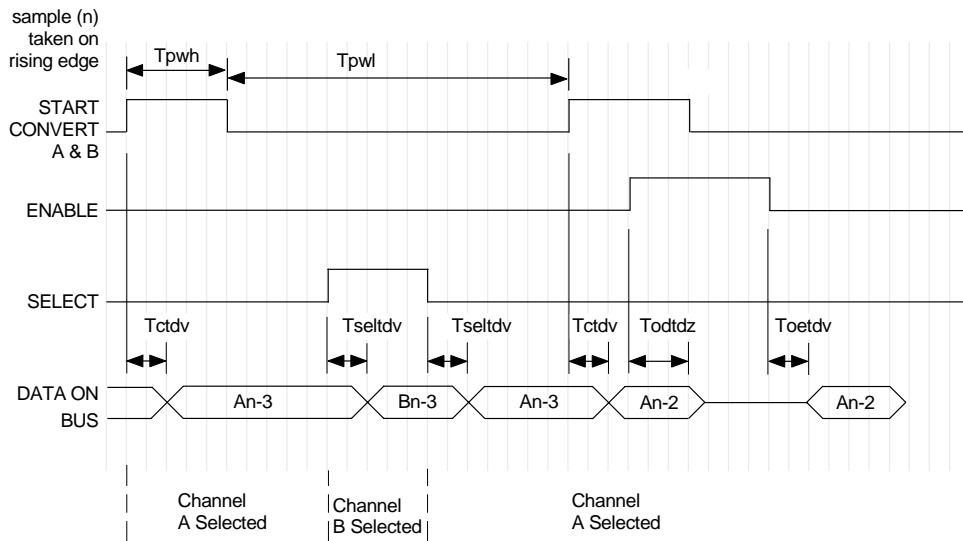

Figure 2. Timing Diagram

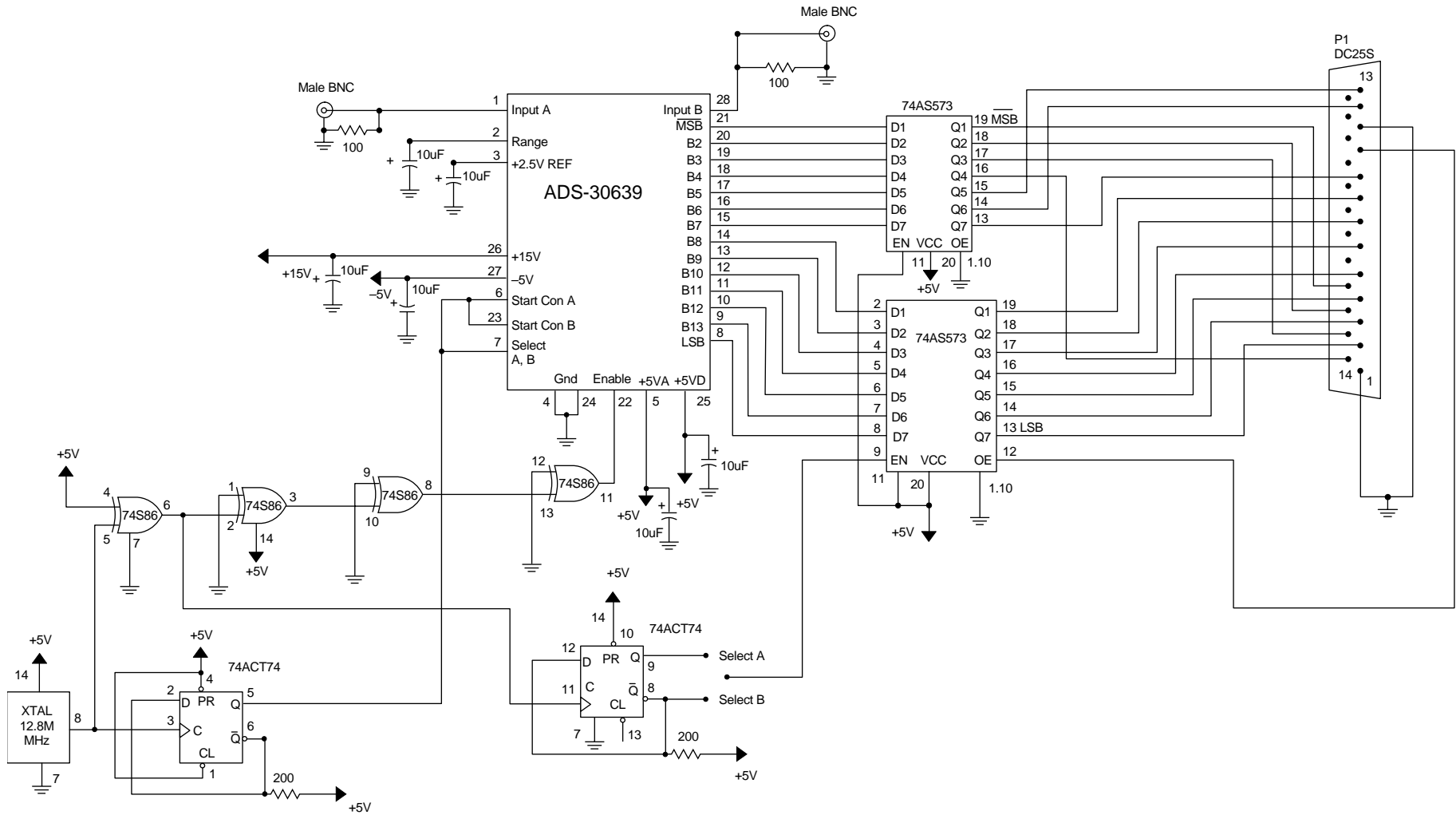
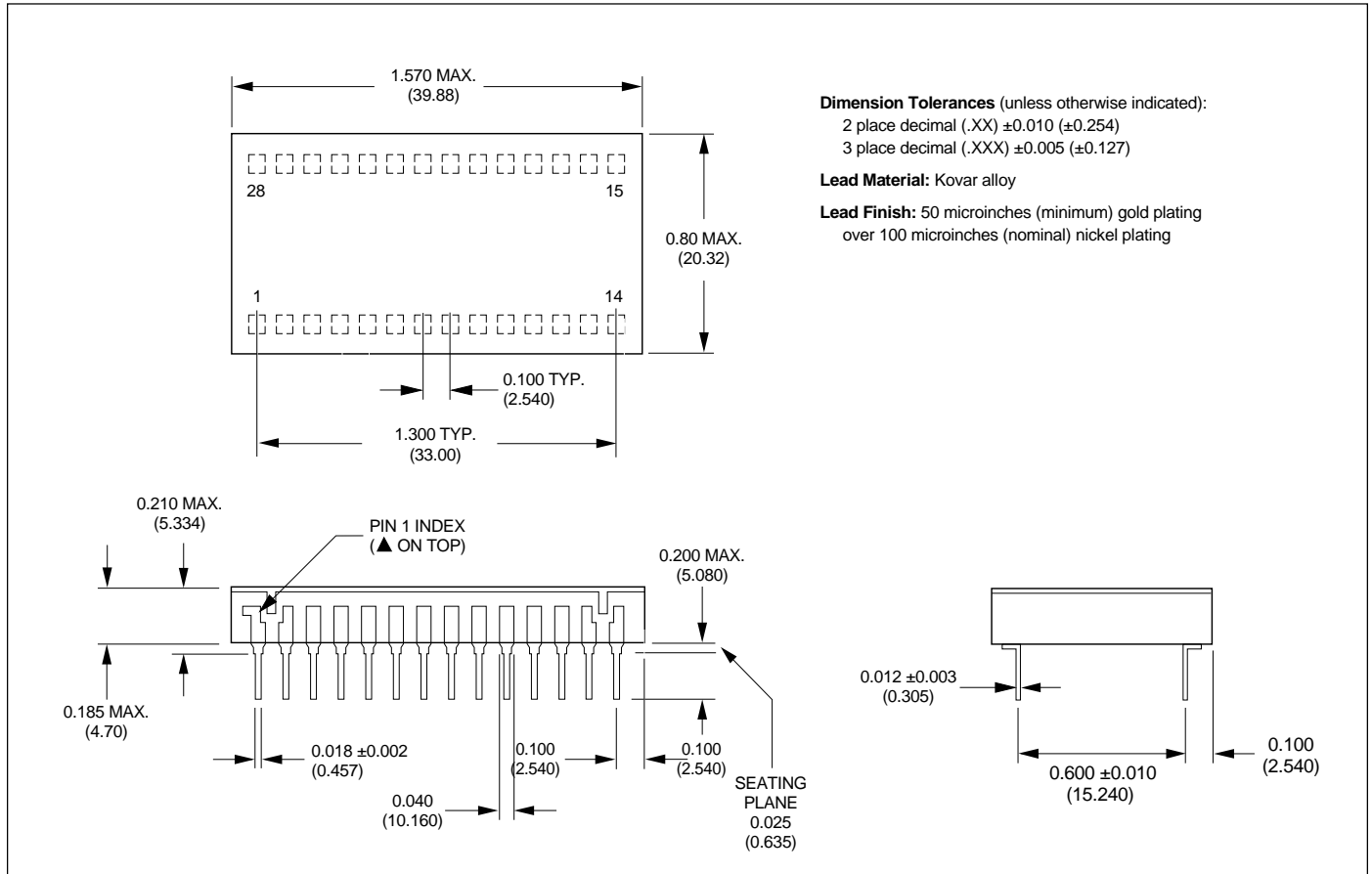

Figure 3. ADS-30639 Connection Diagram

MECHANICAL DIMENSIONS
INCHES (mm)



ORDERING INFORMATION

MODEL	OPERATING TEMP. RANGE	28-PIN PACKAGE
ADS-30639	-55 to +125°C	DDIP