



**Product Description**

RFMD's S510065 is a downconverter designed to be used as an Out-of-Band Tuner for use in CATV set-top box and Digital Cable Ready TV applications. The S510065 consists of an input AGC amplifier, mixer, and a video/AGC amplifier. This device offers optimum performance with low power consumption and low distortion. The product is RoHS compliant. The smaller and more cost effective RFFC0085 is the new generation of this product.

**Optimum Technology Matching® Applied**

- GaAs HBT
- GaAs MESFET
- InGaP HBT
- SiGe BiCMOS
- Si BiCMOS
- SiGe HBT
- GaAs pHEMT
- Si CMOS
- Si BJT
- GaN HEMT
- InP HBT
- RF MEMS
- LDMOS

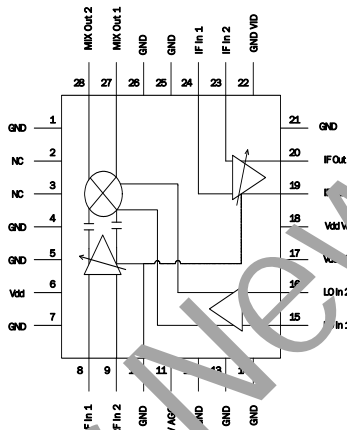

**Features**

- 3.3V Single Supply Operation
- Low Power Consumption (400mW)
- Low Distortion: -55dBc at 1V<sub>pp</sub>
- 82dB Total Conversion Gain
- 5dB Total Gain Control Range
- Low LO-RF Leakage

**Applications**

- Cable Set-Top Boxes
- Digital Cable Ready TV Sets

Parameter	Specification			Unit	Condition
	Min.	Typ.	Max.		
RF Input Frequency Range	50		150	MHz	High Side L.O.
LO Input Frequency Range	80		220	MHz	High Side L.O.
Maximum Conversion Gain		82		dB	Includes saw filter loss
AGC Voltage	0		3	V	
AGC Dynamic Range	50	55		dB	V <sub>AGC</sub> =0V to 3V
Third Order Intermodulation	50	55		dBc	1V <sub>pp</sub> Differential Output, 1KΩ load
IF Output Level		1	2	V <sub>pp</sub>	Differential Output, 1KΩ load
Noise Figure		13	15	dB	V <sub>AGC</sub> =3V
RF Amp/Mixer Conversion Gain		41		dB	V <sub>AGC</sub> =3V
Video Amplifier Gain			55	dB	V <sub>AGC</sub> =3V
LO Leakage at the RF port		-95	-85	dBm	
<b>DC Performance</b>					
Supply Voltage	3.2	3.3	3.4	V	
Supply Current		117	140	mA	

Test Conditions: T<sub>A</sub>=25°C, V<sub>DD</sub>=3.3V, unless otherwise specified

## Absolute Maximum Ratings

Parameter	Rating	Unit
Supply Voltage ( $V_{DD, GND}$ )	-0.3 to +3.6	V
Operating Temperature ( $T_{OP}$ )	-40 to +85	°C
Storage Temperature ( $T_{STG}$ )	-65 to +150	°C
Junction Temperature	+150	°C
Thermal Resistance (Oja)	34	°C/W

Operation of this device beyond any one of these limits may cause permanent damage. For reliable continuous operation, the device voltage and current must not exceed the maximum operating values specified in the table on page one.



**Caution!** ESD sensitive device.

Exceeding any one or a combination of the Absolute Maximum Rating conditions may cause permanent damage to the device. Extended application of Absolute Maximum Rating conditions to the device may reduce device reliability. Specified typical performance or functional operation of the device under Absolute Maximum Rating conditions is not implied.

RoHS status based on EU Directive 2011/65/EU (at time of this document revision).

The information in this publication is believed to be accurate and reliable. However, no responsibility is assumed by RF Micro Devices, Inc. ("RFMD") for its use, nor for any infringement of patents, or other rights of third parties, resulting from its use. No license is granted by implication or otherwise under any patent or other rights. RFMD, RFMD reserves the right to change component circuitry, recommended application circuitry and specifications at any time without prior notice.



RFMD Green: RoHS compliant per EU Directive 2011/65/EU, Halogen free per IEC 61249-2-21, < 1000 ppm each of antimony, bismuth, bromine, cerium, cobalt, copper, lead, manganese, nickel, silver, tin, titanium, tungsten, vanadium, zinc, zirconium, and red phosphorus as a flame retardant, < 200 ppm antimony in solder.

## Typical Performance Curves

Conversion Gain vs. RF

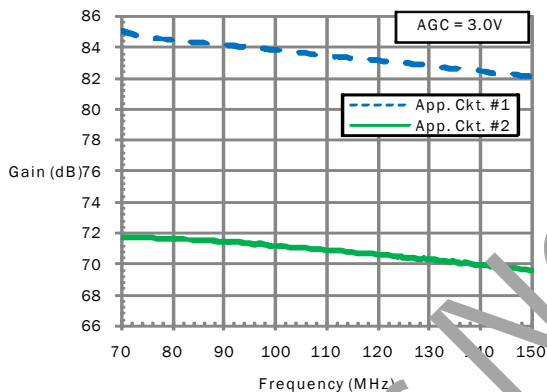

IF Outputs vs. Frequency

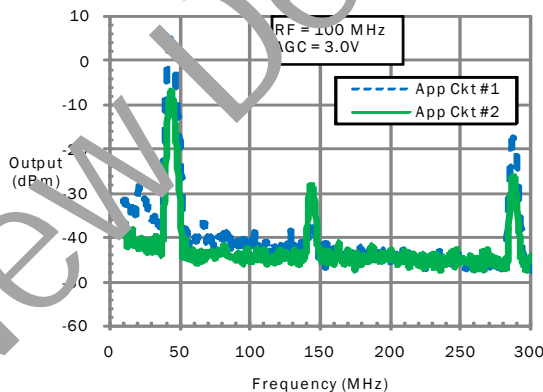

Conversion Gain vs. LO Power

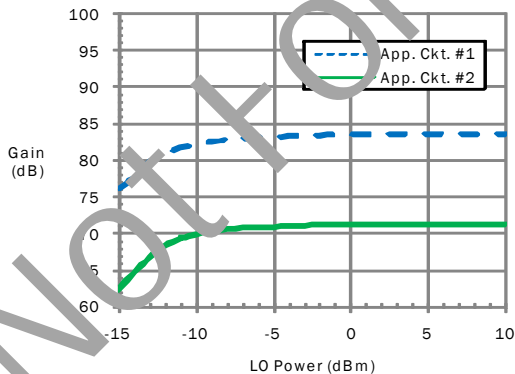

Conversion Gain vs. AGC

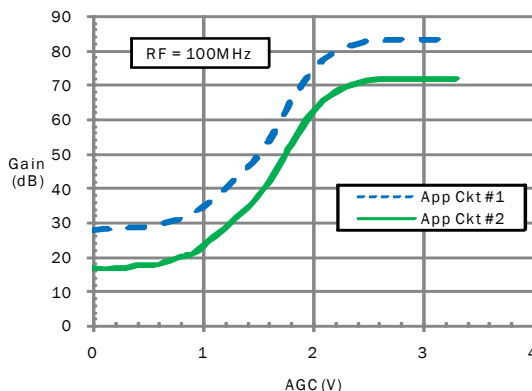

Typical Performance Curves Continued

LO Leakage at RF vs. LO Frequency

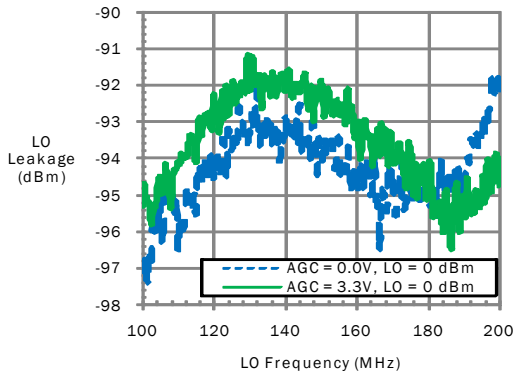

Noise Figure vs. AGC

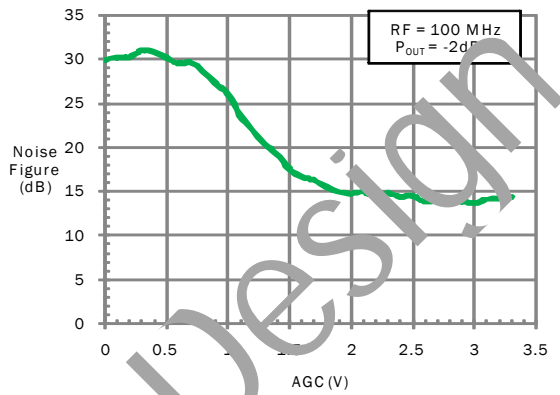

IM3 vs. AGC

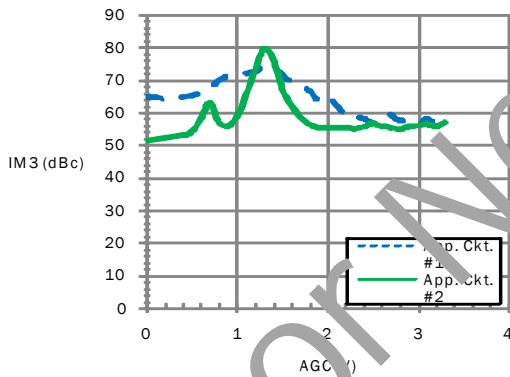

I<sub>DC</sub> Voltage vs. Current

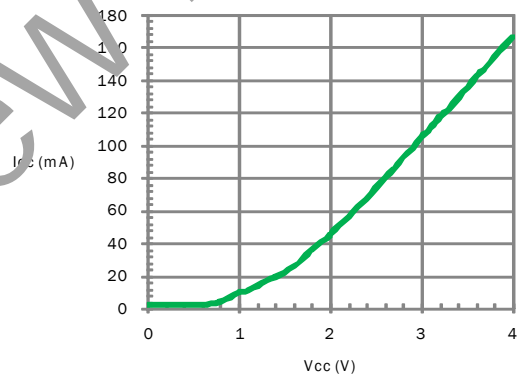

Pin	Function	Description
1,4,5, 10,12, 13,14, 21,25, 26	GND	Ground pins. Connect to the ground plane with shortest possible length to minimize inductance.
2	MIX IN2	No connection.
3	MIX IN1	No connection.
6	VDD RF	RF AMP Supply, +3.3V
7	GND RF	RF AMP Ground. See GND.
8	RF IN1	RF AMP Positive Input, Input Impedance, 1K $\Omega$ single ended. SEE APPLICATION.
9	RF IN2	RF AMP Negative Input. SEE APPLICATION.
11	AGC	Automatic Gain Control, Min Gain at AGC=0V, Max Gain at AGC=3.0V.
15	LO IN1	LO Buffer Positive Input
16	LO IN2	LO Buffer Negative Input.
17	VDD LO	LO Buffer Supply, +3.3V.
18	VDD VID	VIDEO AMP Input Stage Supply, +3.3V.
19	IF OUT1	VIDEO AMP Negative Output. This pin and IF OUT2 form a 1K $\Omega$ output impedance. Open Drain. SEE APPLICATION.
20	IF OUT2	VIDEO AMP Positive Output. See IF OUT1.
22	GND VID	VIDEO AMP Ground. See GND.
23	IN IN1	VIDEO AMP Negative Input.
24	IF IN2	VIDEO AMP Positive Input.
27	MIX OUT1	MIXER Positive Output. Open Drain. SEE APPLICATION.
28	MIX OUT2	MIXER Negative Output. Open Drain. SEE APPLICATION.

Not For New Design

**\*Important Application Note:**

The following low pass filter should proceed the S510065-55Z in all applications. This filter is used to prevent or reduce down stream interference.

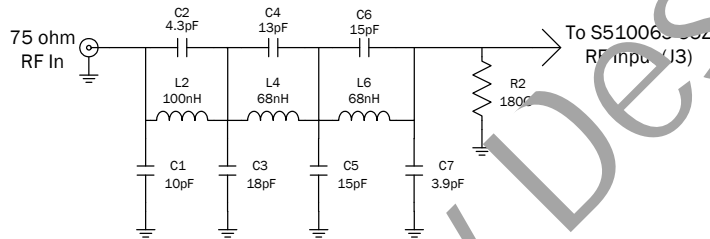

**Component List for Low Pass Filter:**

Circuit Symbol	Value
C7	3.9pF
C2	4.3pF
C1	10pF
C4	13pF
C5, C6	15pF
C3	18pF
L4, L6	68nH
L2	100nH
R2	180 ohm

## Application Schematic - 1

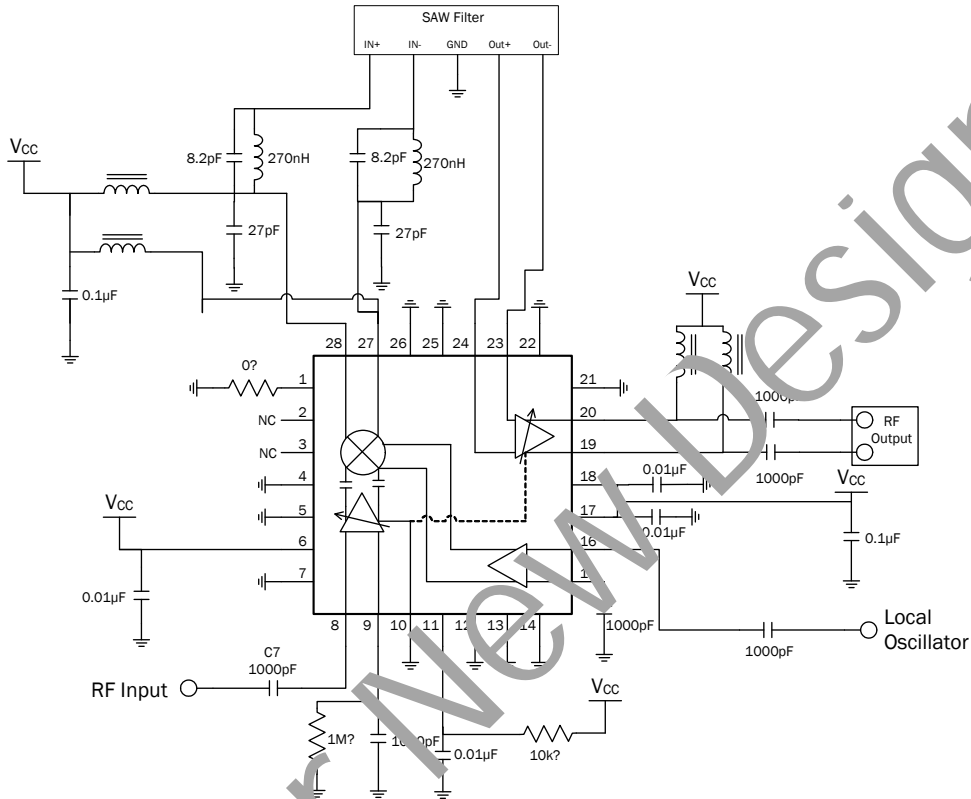

### RF Amplifier

This amplifier provides a maximum gain of 9 dB. The gain is programmed by applying a DC voltage (from 0V to 3V) to the AGC pin, providing 27 dB of range.

### Downconversion Mixer

This double balanced mixer has 12 dB of conversion gain. The outputs of the mixer are both open drain and require pull-up inductors to  $V_{DD}$ .

### Video Amplifier

This amplifier provides a maximum gain of 55 dB. The gain is programmed by applying a DC voltage (from 0V to 3V) to the AGC pin, providing 28 dB of range. The outputs of the video amp are both open drain and require pull-up inductors to  $V_{DD}$ .

The RF amplifier and video amplifier are controlled by a single AGC so the overall dynamic range is the sum of the RF amplifier range and the video amplifier range.

Application Schematic - 2

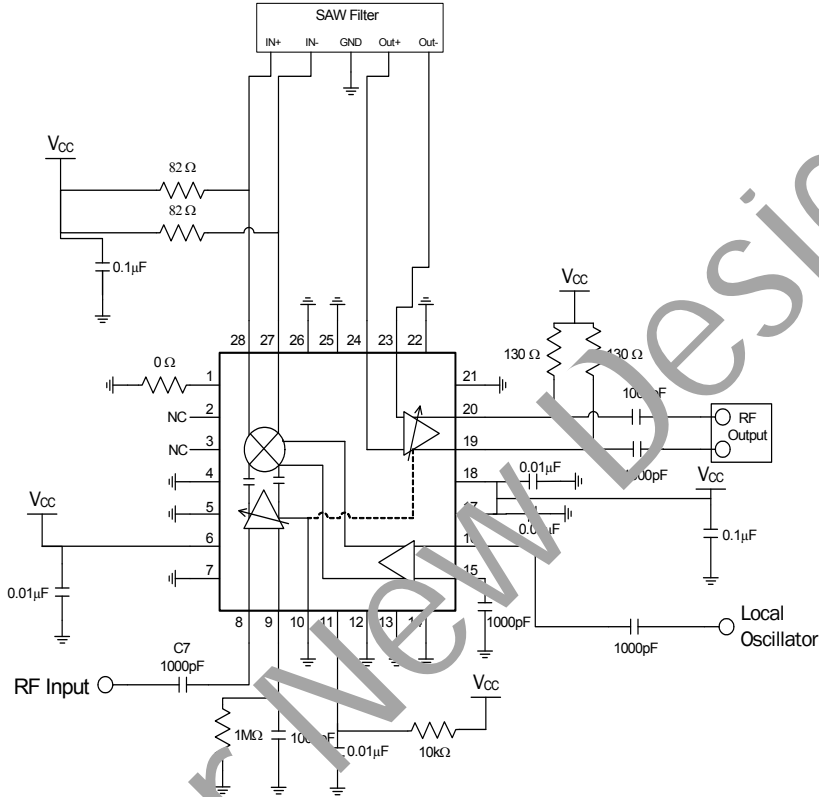

Not For New Design

## Evaluation Test Circuit

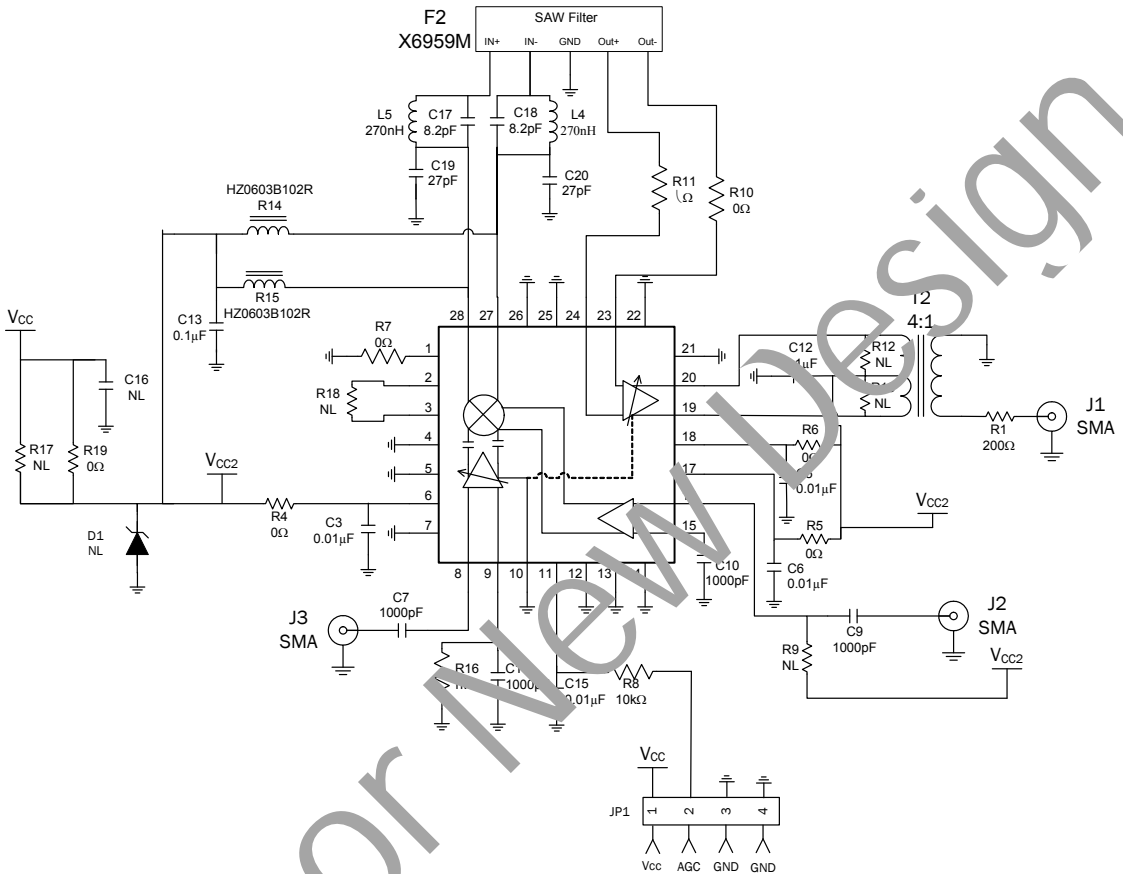

### Component Table:

Circuit Symbol	Value	Comments
L4, L5	270nH	
C12, C13	0.1µH	
C17, C18	8.2pF	
C19, C20	27pF	
C3, C5, C6, C15	0.01µH	
C7, C9, C10, C11	1000pF	
R4, R5, R6, R10, R11, R19	0Ω	
R8	10KΩ	
R1	200Ω	
R14, R15		Ferrite Bead
R16	1MΩ	
T2	4:1	
C16, D1, R9, R12, R13, R17, R18		Not Placed
J1, J2, J3		SMA
JP1		4 Pin Header
F2	SAW	EPCOS X6959M

### Package Drawing

Dimensions in inches (millimeters)

QFN 28

Refer to drawing posted at [www.rfmd.com](http://www.rfmd.com) for tolerances.

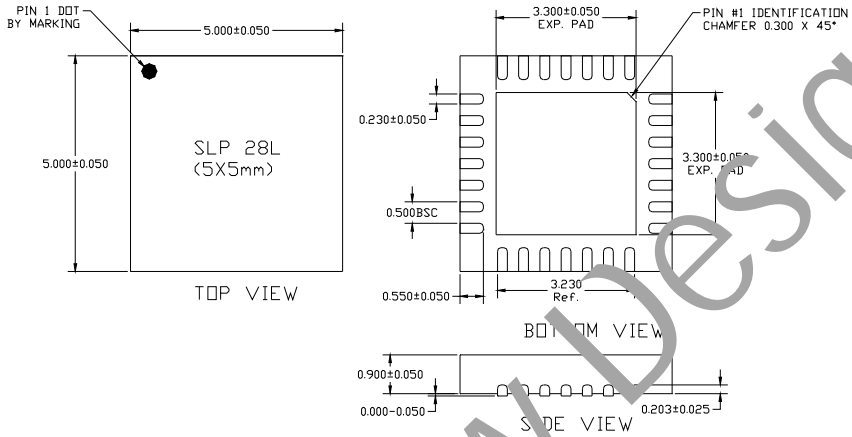

Not For New Design

**Land Pattern For Terminals and Thermal/Ground Pad**

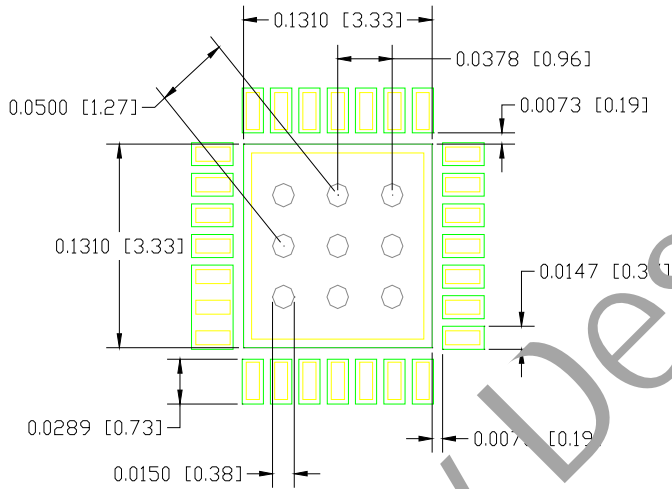

**Ordering Information**

Part Number	Description	Reel Size	Devices/Reel
S51006555ZSB	5 pcs Sample Bag	N/A	N/A
S51006555ZSQ	25 pcs Sample Bag	N/A	N/A
S51006555ZSR	CATV Out of Band Tuner	7"	100 pcs
S51006555Z	CATV Out of Band Tuner	7"	3000 pcs