

SMD Oven Controlled Crystal Oscillator

Rakon's Mercury oven controlled crystal oscillator (OCXO) provides comparable stability to 'traditional' OCXOs in a small SMD package.



Product description

Using Rakon's proprietary Mercury ASIC, the OCXO is capable of short term ageing of typically less than ± 2 ppb per day, with temperature stability down to ± 10 ppb. The miniature, highly integrated oven used ensures short warm up times with power consumption of only 350 mW at room temperature.

Applications

- Network timing and synchronisation
- IP timing
- LTE

Features

- ± 20 ppb stability over -40 to 85°C
- World's smallest OCXO

Specifications

1.0 SPECIFICATION REFERENCES

Line	Parameter	Description
1.1	Model description	RFPO45
1.2	RoHS compliant	Yes
1.3	Package size	9.7 mm x 7.5 mm x 4.3 mm

2.0 FREQUENCY CHARACTERISTICS

Line	Parameter	Test Condition	Value	Unit
2.1	Frequency range	Frequency range available (note 1)	10 to 26	MHz
2.2	Frequency calibration	At 25°C \pm 2°C, at time of shipment, reference to nominal frequency (note 2)	± 0.5 max	ppm
2.3	Reflow shift	After 1 hour recovery at 25°C	± 1 max	ppm
2.4	Frequency stability over temperature in still air	Reference to $(F_{max} + F_{min})/2$, see model code builder (note 3)	± 10 to 100	ppb
2.5	Temperature range	The operating temperature range over which the frequency stability is measured (note 3)	-40 to 85	°C
2.6	Frequency slope in still air	Temperature ramp 1°C/minute max.	± 0.5 to 2	ppb/°C
2.7	Supply voltage stability	$\pm 5\%$ variation, reference to frequency at 3.3V, typical...	± 10	ppb
2.8	Load sensitivity	± 5 pF variation, reference to frequency at 15pF, typical...	± 10	ppb
2.9	Warm-up time	Note 4, typically less than...	3	minutes
2.10	g-sensitivity	Gamma vector of all three axes from 30 Hz to 1500 Hz, typically less than...	2	ppb/g
2.11	Holdover drift	24 hours, temperature variation $\leq \pm 1^\circ\text{C}$ (note 5), typically less than...	± 2.5 to 4	ppb
2.12	Free-run accuracy	All causes, 20 years life, reference to nominal frequency	± 4.6 max	ppm
2.13	Loop bandwidth for wander generation compliance	MTIE compliant with GR-1244 Fig 5-5 & G.812 Type III Fig1 (≤ 100 ns), TDEV compliant with GR-1244 Fig 5-4 & G.812 Type III Fig2 (≤ 10 ns), oscillator stabilised 24 hours at Constant temperature ($\pm 1^\circ\text{C}$, still air), data collected over 100,000 seconds at 1 second intervals (-3dB cut-off, 2nd order high pass loop filter)	3 min	mHz

3.0 FREQUENCY AGING

Line	Parameter	Test Condition	Value	Unit
3.1	Long term stability	Per day (note 5), typically less than...	±2	ppb
3.2	Long term stability	First year	±1 max	ppm
3.3	Long term stability	20 years	±3 max	ppm

4.0 ROOT ALLAN VARIANCE

Line	Parameter	Test Condition	Value	Unit
4.1	Root Allan Variance	Typical value for a 20 MHz unit at 25°C, tau = 0.1s	7	E-11
4.2	Root Allan Variance	Typical value for a 20 MHz unit at 25°C, tau = 1.0s	7	E-11
4.3	Root Allan Variance	Typical value for a 20 MHz unit at 25°C, tau = 10s	7	E-11
4.4	Root Allan Variance	Typical value for a 20 MHz unit at 25°C, tau = 100s	8	E-11
4.5	Root Allan Variance	Typical value for a 20 MHz unit at 25°C, tau = 1000s	8	E-11

5.0 POWER SUPPLY

Line	Parameter	Test Condition	Value	Unit
5.1	Supply voltage	±5%	3.3	V
5.2	Input power	warm up, -40°C to 85°C devices, typical...	1000	mW
5.3	Input power	warm up, -20°C to 70°C devices, typical...	800	mW
5.4	Input power	Steady state in still air at 25°C, -40°C to 85°C devices	400 max	mW
5.5	Input power	Steady state in still air at 25°C, -20°C to 70°C devices	350 max	mW

6.0 HCMOS OSCILLATOR OUTPUT

Line	Parameter	Test Condition	Value	Unit
6.1	Output waveform	HCMOS		
6.2	Output voltage level low	Measured with a capacitive load of 15pF	10 max	%Vcc
6.3	Output voltage level high	Measured with a capacitive load of 15pF	90 min	%Vcc
6.4	Rise and fall times	Measured with a capacitive load of 15pF	4 max	ns
6.5	Duty cycle	Measured at 50% level	45 to 55	%
6.6	Output load	Nominal	15	pF

7.0 SSB PHASE NOISE

Line	Parameter	Test Condition	Value	Unit
7.1	SSB phase noise power density at 1 Hz offset	Typical value for a 12.8MHz carrier at 25°C	-70	dBc/Hz
7.2	SSB phase noise power density at 10 Hz offset	Typical value for a 12.8MHz carrier at 25°C	-96	dBc/Hz
7.3	SSB phase noise power density at 100 Hz offset	Typical value for a 12.8MHz carrier at 25°C	-123	dBc/Hz
7.4	SSB phase noise power density at 1kHz offset	Typical value for a 12.8MHz carrier at 25°C	-143	dBc/Hz
7.5	SSB phase noise power density at 10kHz offset	Typical value for a 12.8MHz carrier at 25°C	-152	dBc/Hz
7.6	SSB phase noise power density at 100kHz offset	Typical value for a 12.8MHz carrier at 25°C	-153	dBc/Hz
7.7	SSB phase noise power density at 1MHz offset	Typical value for a 12.8MHz carrier at 25°C	-154	dBc/Hz

8.0 ENVIRONMENTAL

Line	Parameter	Test Condition	Value	Unit
8.1	Storage temperature		-55 to 125	°C
8.2	Acceleration steady state	IEC 60068-2-7 test Ga, 5000g, 10s (at peak acceleration), Y-axis only		
8.3	Moisture sensitivity	IPC/JEDEC J-STD-020, Class 1		
8.4	Temperature cycling	IEC 60068-2-14 test Na, 400 cycles, -40°C to +125°C		
8.5	Solderability	JESD 22-B102D, Method 2 Preconditioning 150°C, 16 hours		
8.6	Humidity	EIA/JEDEC22-A101, 85°C/85%R.H., 1000 hours		
8.7	Shock	IEC 60068-2-27, test Ea; 1500g, 0.5ms, 18 shocks total		
8.8	Vibration	IEC 60068-2-6, test Fc: 20g, 60 to 2000Hz 12 hours total		
8.9	RoHS	Parts are fully compliant with the European Union directive 2002/95/EC on the restriction of the use of certain hazardous substances in electrical and electronic equipment. Note parts are suitable for assembly using both Lead-free solders and Tin/Lead solders		

9.0 PIN CONNECTIONS

Line	Parameter	Description
9.1	Pin 1: Do Not Connect	
9.2	Pin 2: GND	
9.3	Pin 3: OUTPUT	
9.4	Pin 4: VCC	For correct operation decouple the supply voltage with a 10 µF capacitor close to the oscillator

10.0 MARKING

Line	Parameter	Description
10.1	Type	Laser marked
10.2	Line 1	RAKON
10.3	Line 2	Part number (Mxxxx)
10.4	Line 3	Frequency in MHz (xx.x MHz)
10.5	Line 4	Pin 1 identifier (indent), and date / location code (YYWWX)

11.0 MANUFACTURING INFORMATION

Line	Parameter	Description
11.1	Reflow	IPC/JEDEC J-STD-020, Package reflow temperature for the Pb-Free process is 250°C, or for the Sn-Pb eutectic process is 220°C. The solder reflow processes are as per the attached profiles
11.2	Packaging description	Tape and reel. 24mm wide tape and Ø330mm (Ø13") reel. Standard packing quantity is 100 to 1000 units per reel

12.0 SPECIFICATION NOTES

Line	Parameter	Description
12.1	Note 1	Standard frequencies are 10, 12.8, 13, 19.44, 20, 25 and 26 MHz. Other frequencies available on request.
12.2	Note 2	The characteristics of the component may be temporarily affected by the processes of assembly and soldering. The frequency specifications apply 48 hours after assembly. Nominal conditions apply unless otherwise stated.
12.3	Note 3	Stability / temperature range options other than listed may be available upon request. Please consult sales office for availability.
12.4	Note 4	Time needed for frequency to be within ±20 ppb reference to frequency after 1 hour, at 25°C. Parameter is frequency, assembly and operating history dependent.
12.5	Note 5	After 30 days of continuous operation.

13.0 DISCLAIMER

Line Parameter

Description

13.1 Disclaimer

“Samples supplied according to this specification are supplied from our development or pre-production programme and as such are not qualification approved products. No condition, warranty or representation regarding quality, suitability, performance, life or continuation of supply is given or implied and Guarantee in clause 6.1 of our standard Conditions of Sale is not applicable. The right is reserved to change the design or specification or cease supply without notice.” RAKON UK Limited

Drawing Name: RFPO40/45 Model Drawing

MODEL DRAWING

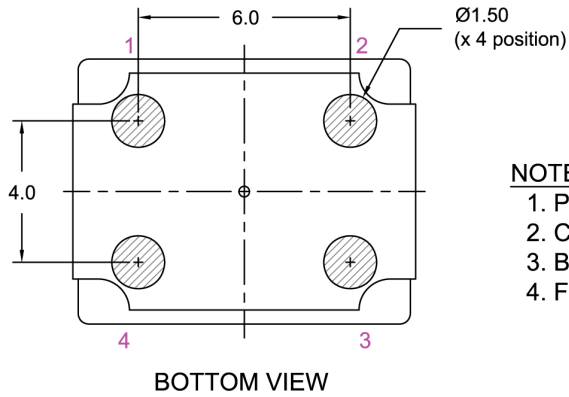
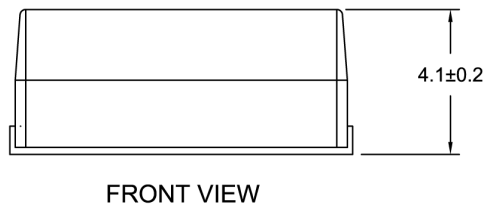
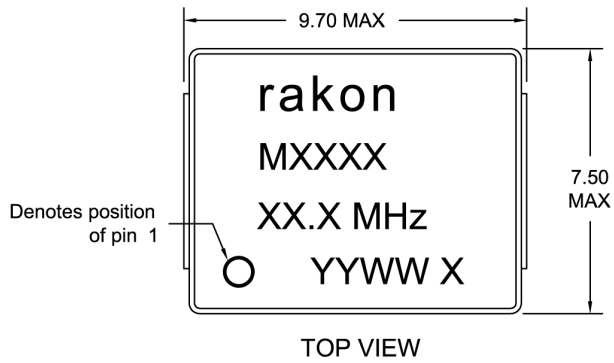

NOTE:

1. Pin connections are detailed in the specification.
2. Cover: Plastic
3. Base: FR4
4. Finish: 0.05 ~ 0.13 µmGold over 3 ~ 6 µm Nickel.

RECOMMENDED PAD LAYOUT - TOP VIEW

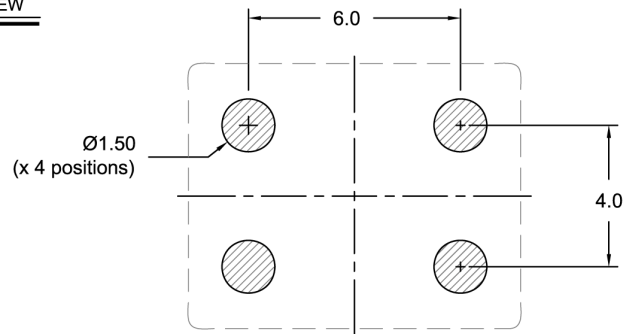

TITLE: RFPO40/45 MODEL DRAWING

RELATED DRAWINGS:

FILENAME: CAT646

REVISION: C

DATE: 25-Jan-12

SCALE: 5 : 1

Millimetres

TOLERANCES:

XX =

X.X = ±0.2

X.XX = ±0.10

X.XXX =

X° =

Hole =

rakon

© 2009 Rakon Limited

Drawing Name: Mercury-RFPO Model Code

MODEL CODE BUILDER:

RFPOX X XX X XX

PRODUCT CODE

RFPO 4 = Mercury OCXO 9x7 SMD
 RFPO 5 = Mercury OCXO 14x9 SMD
 RFPO 6 = Mercury OCXO 20x13 DIL

MODEL CODE

1 = 3.3V HCMOS
 2 = 5.0V HCMOS
 3 = 3.3V Clipped Sine Wave
 4 = 5.0V Clipped Sine Wave
 5 = 3.3V HCMOS Stratum 3+

RoHS CODE

LF = RoHS compliant

FREQUENCY ADJUSTMENT CODE

A = Pin 1 Vc for voltage control option
 B = Pin 1 NC for fixed frequency option

TEMPERATURE STABILITY CODE

Temperature range	Stability (±ppb)				
	10	20	25	50	100
-20°C to 70°C	US	VS	PS	RS	-
-40°C to 85°C	-	VX	PX	RX	SX

EXAMPLE:

RFPO5 1 RX A LF

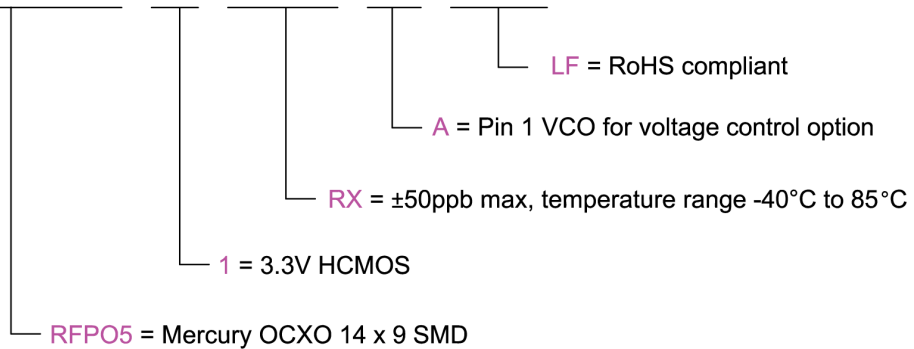

TITLE: MERCURY-RFPO MODEL CODE BUILDER

FILENAME: CAT645

RELATED DRAWINGS:

REVISION: A
 DATE: 12-Oct-11
 SCALE: NTS
 Millimetres



© 2009 Rakon Limited

Drawing Name: RFPO40 Series Reflow

Pb-Free Reflow Soldering Profile *

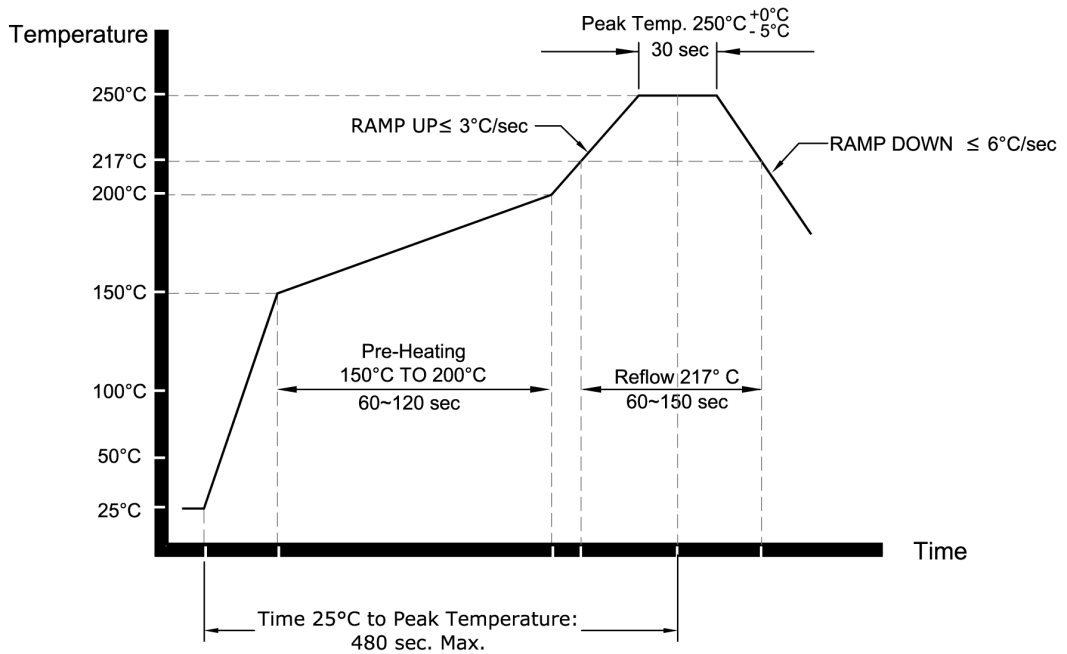

Sn-Pb Eutectic Reflow Soldering Profile *

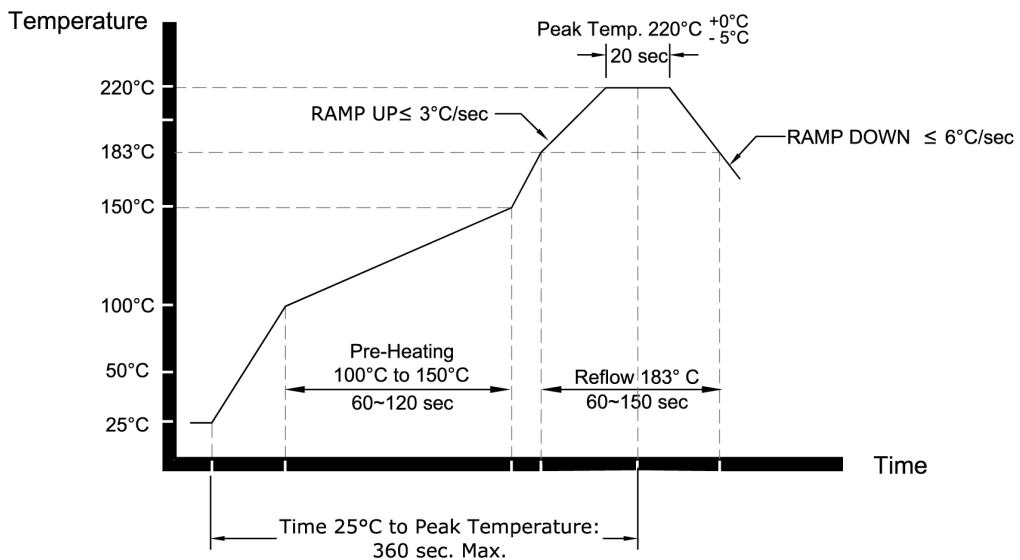

* NOTE:

These profile were used during the qualification testing of the product and therefore represents worst case conditions. It is not recommended for use by the customer in the actual assembly of these parts.

TITLE: RFPO40 SERIES REFLOW

FILENAME: CAT649

RELATED DRAWINGS:

REVISION: A

DATE: 25-Oct-11

SCALE: NTS

Millimetres

rakon

© 2009 Rakon Limited