

## Low-Current Superhet Remote Control Receiver

### Description

The U4311B is a monolithic integrated circuit in bipolar technology for low-current UHF remote control super-heterodyne receivers in amplitude- or frequency-modulated mode. Typical applications are keyless car

lock-, alarm- or tele-control remote indication systems. Especially for automotive applications, it supports a superhet design with about 1mA total current consumption as required by the car manufacturers.

### Features

- Usable for amplitude- and frequency-modulated transmission systems
- Extremely low quiescent current (approximately 1 mA in standby mode due to wake-up concept)
- Wide power supply voltage range 3 to 13 V
- Sensitive IF amplifier for 10.7-MHz operating frequency
- Logarithmic AM demodulator
- FM demodulator
- Monoflop exit to wake up a microcontroller
- High-performance operational amplifier to realize a data recovering filter
- Non-inverting clamping comparator with amplitude-dependent hysteresis for data regeneration

### Block Diagram

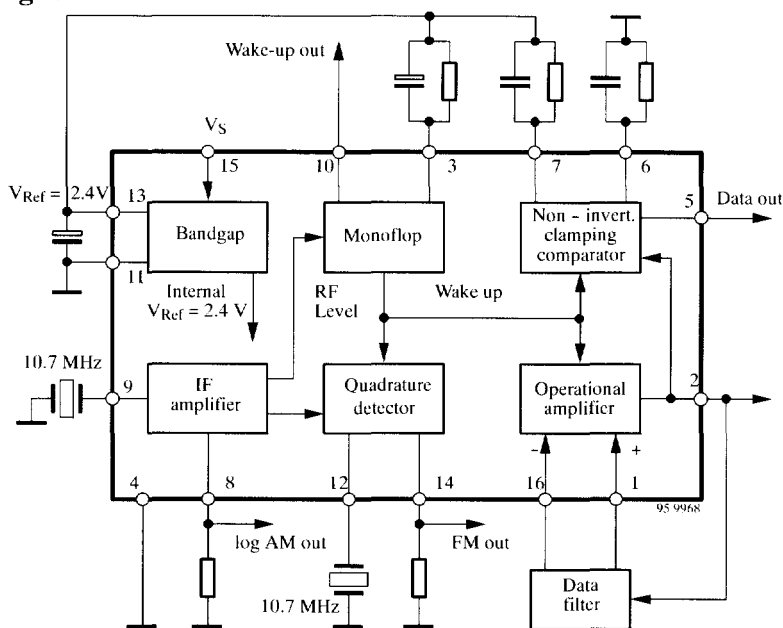

Figure 1. Block diagram

### Ordering Information

Extended Type Number	Package	Remarks
U4311B-M	DIP16	
U4311B-MFL	SO16L	

## Pin Description

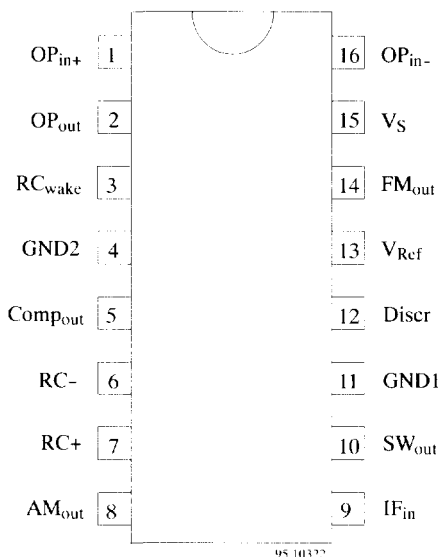

Figure 2. Pin description

Pin	Symbol	Function
1	OP <sub>in+</sub>	OP amplifier non-inverted input
2	OP <sub>out</sub>	OP amplifier output
3	RC <sub>wake</sub>	RC wake-up reset time
4	GND2	Ground of the logical circuits
5	Comp <sub>out</sub>	Comparator output
6	RC-	Comparator time constant
7	RC+	Comparator time constant
8	AM <sub>out</sub>	AM current output
9	IF <sub>in</sub>	IF input
10	SW <sub>out</sub>	Wake-up output
11	GND1	Ground of the analog circuits
12	Discr	FM discriminator tank
13	V <sub>Ref</sub>	Reference voltage
14	FM <sub>out</sub>	FM discriminator output
15	V <sub>S</sub>	Supply voltage
16	OP <sub>in-</sub>	OP amplifier inverted input

Internal connections see figures 4 to 19

## Absolute Maximum Ratings

Parameters	Symbol	Value	Unit
Supply voltage	V <sub>S</sub>	13	V
Power dissipation T <sub>amb</sub> = 85°C	P <sub>tot</sub>	400	mW
Junction temperature	T <sub>j</sub>	125	°C
Ambient temperature	T <sub>amb</sub>	-40 to +85	°C
Storage temperature	T <sub>stg</sub>	-55 to +125	°C

## Thermal Resistance

Parameters	Symbol	Value	Unit
Junction ambient	R <sub>thJA</sub>	120	K/W
	R <sub>thJA</sub>	100	K/W

## Electrical Characteristics

$V_S = 5\text{ V}$ ,  $T_{\text{amb}} = 25^\circ\text{C}$ ,  $f_{\text{in}} = 10.7\text{ MHz}$ ; FM part:  $f_{\text{mod}} = 1\text{ kHz}$ ,  $f_{\text{dev}} = 22.5\text{ kHz}$ ; AM part:  $f_{\text{mod}} = 1\text{ kHz}$ ,  $m = 100\%$  unless otherwise specified

Parameters	Test Conditions / Pins	Symbol	Min.	Typ.	Max.	Unit
<b>Characteristics</b>						
Supply-voltage range	Pin 15	$V_S$	3		12	V
Quiescent supply current	Pin 15	$I_q$		1	1.3	mA
Active supply current	Pin 15	$I_{\text{act}}$		2.8	3.6	mA
<b>Bandgap</b>						
Regulated voltage	Pin 13	$V_{\text{Ref}}$	2.3	2.4	2.5	V
Output current	Pin 13	$I_{\text{Ref}}$			5	mA
Source resistance	Pin 13	$R_{\text{Ref}}$		2.3	5	$\Omega$
External capacitor	Pin 13	$C_{\text{Ref}}$	10			$\mu\text{F}$
Power-supply rejection ratio	$f = 50\text{ Hz}$ Pin 13	psrr		60		dB
<b>IF amplifier</b>						
Input resistance	Pin 9	$R_{\text{in}}$	180	330	520	$\Omega$
Input capacitance	Pin 9	$C_{\text{in}}$		5		pF
Typical internal 3 dB frequency	IF level 70 dB $\mu\text{V}$ Pins 9 and 14	$f_{3\text{dB}}$	8		12	MHz
-3 dB limiting point	Pin 9	$V_{\text{FM}3\text{dB}}$		30		dB $\mu\text{V}$
Recovered data voltage	Pin 14	$V_{\text{FMout}}$	50	130	230	mV
FM detector output resistance	Pin 14	$R_{\text{FMout}}$		50		k $\Omega$
AM rejection ratio	$m = 30\%$ Pins 9 and 14	$AM_{\text{rr}}$		25		dB
Maximum AM input voltage	Pin 9	$V_{\text{AMmax}}$		90		dB $\mu\text{V}$
AM quiescent current	Pin 8	$I_{\text{AMout}}$	10	22	37	$\mu\text{A}$
Maximum AM current	Pin 8	$I_{\text{AMoutmax}}$		100		$\mu\text{A}$
<b>Operational amplifier</b>						
Gain-bandwidth product	Pins 1, 2 and 16	$f_t$	3	4	6.5	MHz
Excess phase	Pins 1, 2 and 16	$\delta$		80		degree
Open loop gain	Pins 1, 2 and 16	$g_0$	50	70	95	dB
Output voltage range	Pin 2	$\Delta V_{\text{out}}$		1.55		V
Common-mode input voltage	Pins 1 and 16	$V_{\text{in}}$	0.7		1.7	V
Input offset voltage	Pins 1 and 16	$V_{\text{os}}$	-2.5	0	+2.5	mV
Maximum output current	Pin 2	$I_{\text{out}}$			5	mA
Common-mode rejection ratio	Pin 1 and 16	cmrr	65	85		dB
Total harmonic distortion	$V_{\text{in}} < 300\text{ mV}$ , $f = 33\text{ kHz}$ , unity gain circuit Pin 2	thd		1	3	%

## Electrical Characteristics (continued)

$V_S = 5\text{ V}$ ,  $T_{\text{amb}} = 25^\circ\text{C}$ ,  $f_{\text{in}} = 10.7\text{ MHz}$ ; FM part:  $f_{\text{mod}} = 1\text{ kHz}$ ,  $f_{\text{dev}} = 22.5\text{ kHz}$ ; AM part:  $f_{\text{mod}} = 1\text{ kHz}$ ,  $m = 100\%$  unless otherwise specified

Parameters	Test Conditions / Pins	Symbol	Min.	Typ.	Max.	Unit
Power-supply rejection ratio	$f = 50\text{ Hz}$ Pin 2	psrr	65	85		dB
<b>Clamping comparator</b>						
Typical common-mode input voltage range	Pin 2	$V_{\text{cmvr}}$	0.8		1.6	V
Maximum distortion voltage	$V_{\text{signal}} = 100\text{ mV}$ , $R_+ = R_- = 50\text{ k}\Omega$ , $C_+ = C_- = 200\text{ nF}$ , $f_{\text{disto}} = 50\text{ Hz}$ , $f_{\text{signal}} = 1\text{ kHz}$ Pin 2	$V_{\text{dmax}}$			200	mV
Output voltage	$V_2 > (V_6 + V_7) / 2$ (10-k $\Omega$ load to $V_{\text{Ref}}$ ) Pin 5	$V_{\text{cout}}$		$V_{\text{Ref}}$		V
Output voltage	$V_2 < (V_6 + V_7) / 2$ (10-k $\Omega$ load to $V_{\text{Ref}}$ ) Pin 5	$V_{\text{cout}}$	0	150	250	mV
<b>Wake-up circuit</b>						
Minimum wake-up level	Pin 9	$V_{\text{in}}$		40		dB( $\mu\text{V}$ ) <sup>1)</sup>
Internal charging resistor	Pin 3	$R_{\text{int}}$		1.5		k $\Omega$
Threshold voltage	Pin 3	$V_{\text{th}}$		1.6		V
Output switch current	Pin 10	$I_{\text{SW}}$	180	250	550	$\mu\text{A}$
Output switch voltage	Pin 10	$V_{\text{SW}}$			5.5	V <sup>2)</sup>
External wake-up resistor	Pins 3 and 13	$R_{\text{WU}}$	22			k $\Omega$
External wake-up capacitor	Pins 3 and 13	$C_{\text{WU}}$			10	$\mu\text{F}$
Hold time ( $\pm 30\%$ )		$t_{\text{h}}$	$\approx 1.5 \times R_{\text{WU}} \times C_{\text{WU}}$			s <sup>3)</sup>
Delay time ( $\pm 30\%$ )		$t_{\text{d}}$	$\approx C_{\text{WU}} \times 0.75\text{ k}\Omega$			s <sup>3)</sup>

- 1) Measured at Pin 9, referred to 330  $\Omega$
- 2) Protected by a Z-diode, see figure 13
- 3) Valid for  $0.1\ \mu\text{F} \leq C_{\text{WU}} \leq 10\ \mu\text{F}$  and  $22\text{ k}\Omega \leq R_{\text{WU}} \leq 680\text{ k}\Omega$

## Circuit Description

### General Functions

The integrated circuit U4311B includes the following functions: IF amplifier, FM demodulator, wake-up circuit with monoflop, operational amplifier, non-inverting data comparator and voltage regulator.

The 10.7-MHz IF signal from the front end passes the integrated IF-amplifier which operates for amplitude- or frequency-modulated signals to either a logarithmic AM demodulator which was implemented to avoid settling-time problems effected by use of an automatic gain control system or a quadrature detector for FM. A data-shaping filter – advantageously realized with the internal high-performance operational amplifier – reduces system bandwidth to an optimized compromise regarding transmission distance and data recognition. Thus, an optimal bit-error rate can be achieved without any further active component.

The comparator connected to the output of the filter has a level-dependent hysteresis and clamps its reference voltage to the signal's minimum and maximum peaks as described later.

Without IF-input signal – in normal mode – only the IF amplifier and the AM demodulator which operates as a

level-strength indicator are activated. If the level of the IF signal increases, the entire circuitry is turned on by the wake-up circuit. This signal is externally available at Pin 10 and can be used to wake up a microcontroller. After an adjustable reset time, determined by the monoflop time constant, the integrated circuit returns to sleep mode. In this case, typically 1-mA supply current is required. An external resistor matched at Pin 3 to ground blocks the wake-up circuit and enables the complete functionality at lower IF levels as can be seen in figures 24 and 27, but supply current increases up to typically 2.8 mA.

### Function of the Clamping Comparator

The output signal of the operational amplifier is fed to the input of the non-inverting comparator and two peak detectors (Q1 and Q2, figure 3). Their time constants are distinguished by RC+ and RC-. The component's value must be adapted to the transmission code. The time constant should be large compared to the bit rate for optimized noise and hum suppression. To compensate the input transistor's base-emitter-voltage differences, these two signals are buffered by Q3 and Q4. The mean value is used as comparator threshold, the difference of the peak values controls the hysteresis. This clamping comparator operates as a data regenerator.

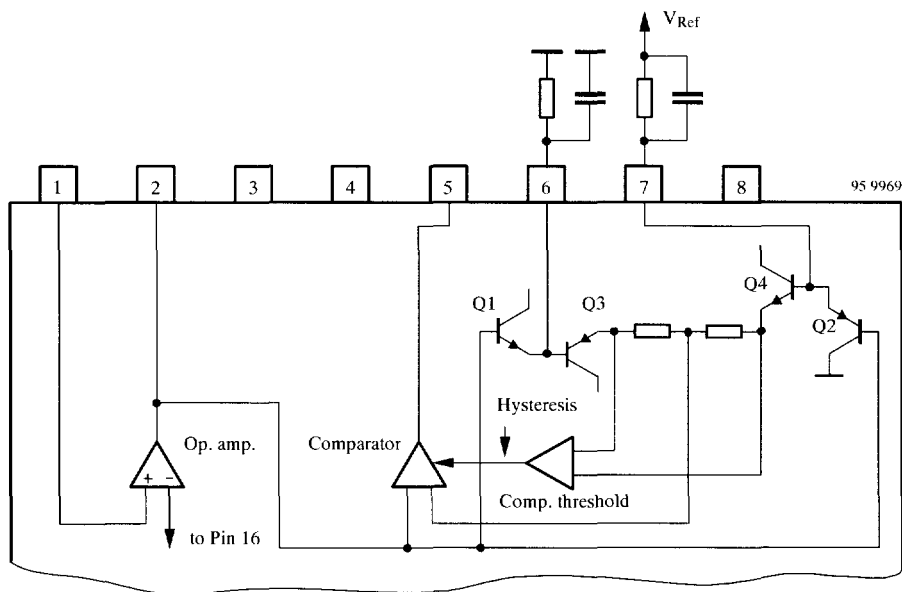

Figure 3. Principle function of the clamping comparator

## Internal Pin Circuitry

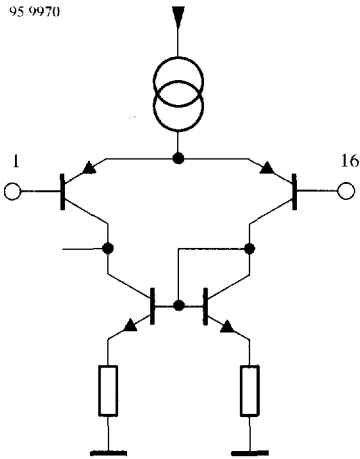

Figure 4. Pin 1 OP<sub>in+</sub>

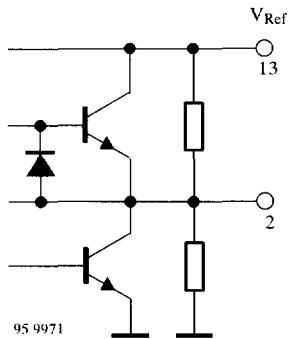

Figure 5. Pin 2 OP<sub>out</sub>

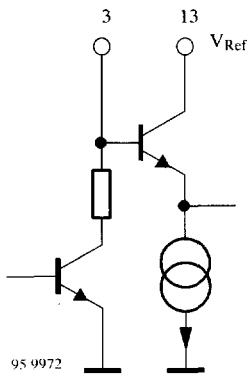

Figure 6. Pin 3 RC<sub>wake</sub>



Figure 7. Pin 4 GND<sub>2</sub>

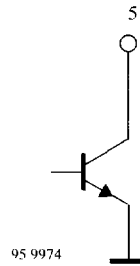

Figure 8. Pin 5 Comp<sub>out</sub>

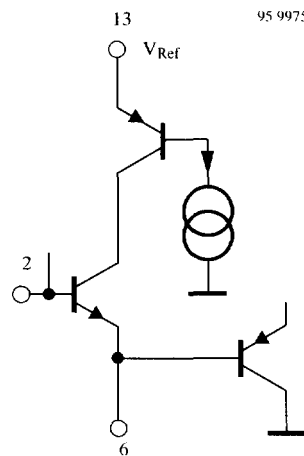

Figure 9. Pin 6 RC<sub>-</sub>

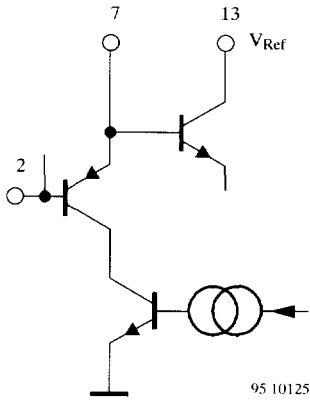

Figure 10. Pin 7 RC+

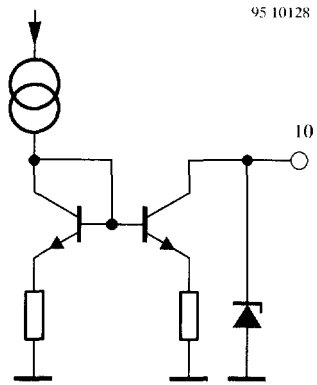

Figure 13. Pin 10 SW<sub>out</sub>

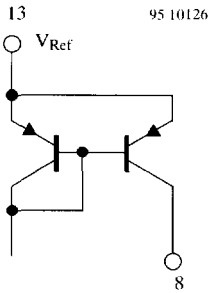

Figure 11. Pin 8 AM<sub>out</sub>



Figure 14. Pin 11 GND1

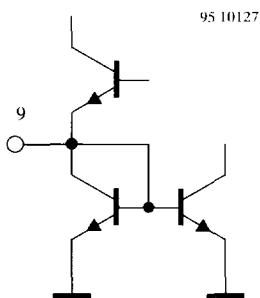

Figure 12. Pin 9 IF<sub>in</sub>

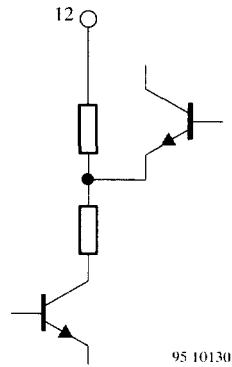

Figure 15. Pin 12 Discr

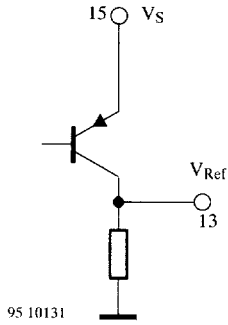

Figure 16. Pin 13  $V_{Ref}$

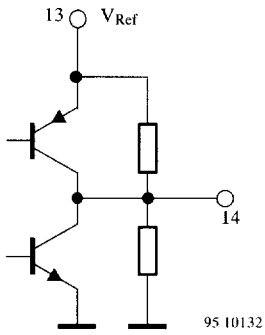

Figure 17. Pin 14  $FM_{out}$

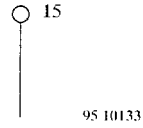

Figure 18. Pin 15  $V_S$

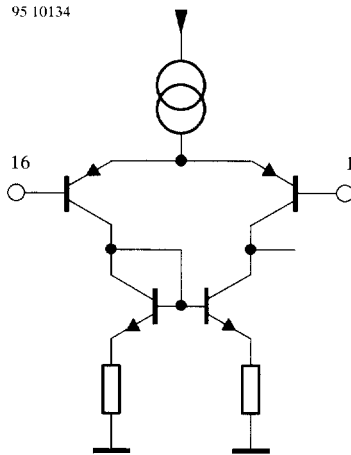

Figure 19. Pin 16  $OP_{in-}$

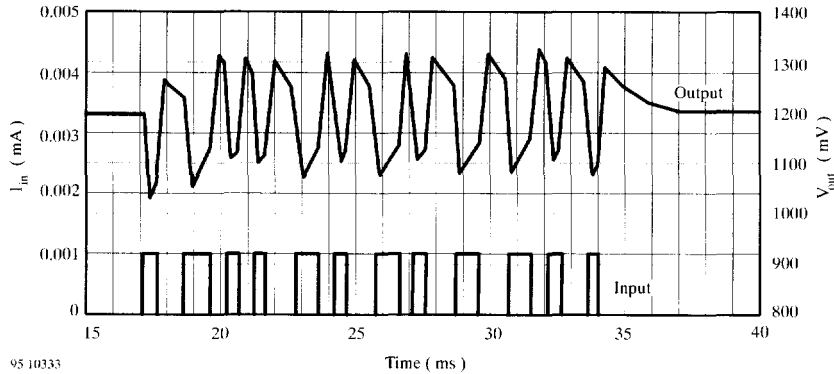

Figure 20. Time domain response of 2-kHz Bessel lowpass data filter

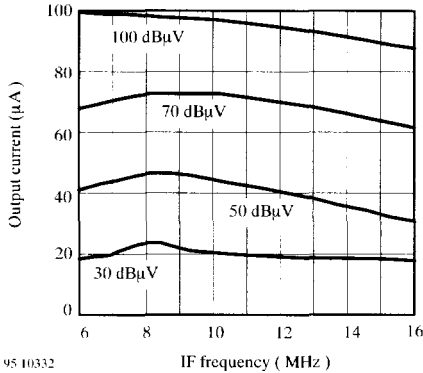

Figure 21. IF-frequency response

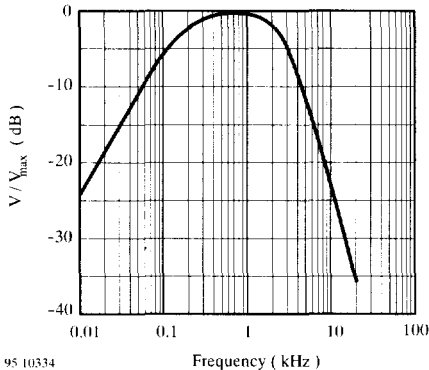

Figure 22. Frequency response of 2-kHz Bessel lowpass data filter

## Data-Recovering Filter

The test circuit in figures 23 and 26 includes an example of a data-recovering filter realized with the components  $R_1$ ,  $R_2$ ,  $C_1$ ,  $C_2$ ,  $C_3$ . It is of a second-order Bessel type with lowpass characteristic, a 3-dB cut-off frequency of 2 kHz and an additional highpass characteristic for suppressing dc and low-frequency ac components. Simulation of time domain and frequency response can be seen in figures 20 and 22. This filter gives a typical application of a 1-kBaud Manchester-code, amplitude-modulated transmission.

The capacitor  $C_2$  is responsible for the highpass cut-off frequency. In order to achieve a correct pulse response, this highpass cut-off frequency should be as low as possible. Figure 20 shows the transient response and the influence of the dc component. The first pulses might be wrong if the highpass cut-off frequency is too low. For this reason, some burst bits must be transmitted before the real data transmission starts. On the other hand, if the cut-off frequency is too high, roof shaping of the rectangle pulses at the operational amplifier output might causes problems.

The lowpass cut-off frequency and the maximum transimpedance  $V_{out}/I_{in}$  are distinguished by the further external elements. Careful design of the data filter enables optimized transmission range. For designing other filter parameters, please refer to filter design handbooks/ programs or request Atmel Wireless & Microcontrollers for support.

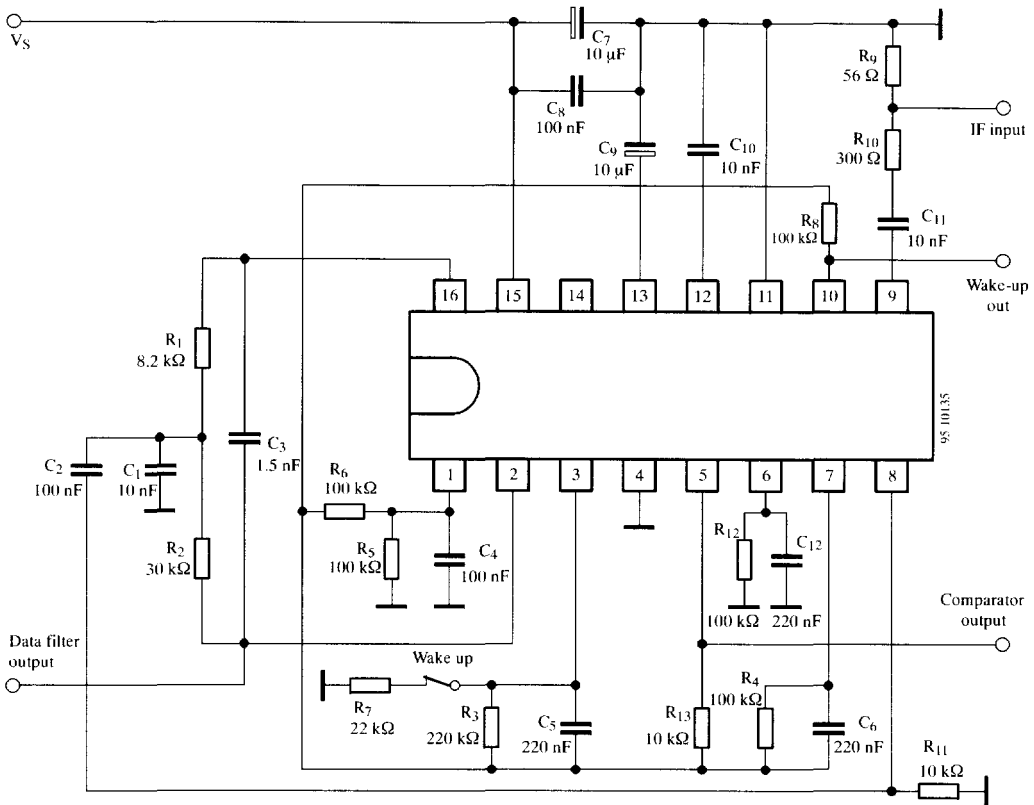
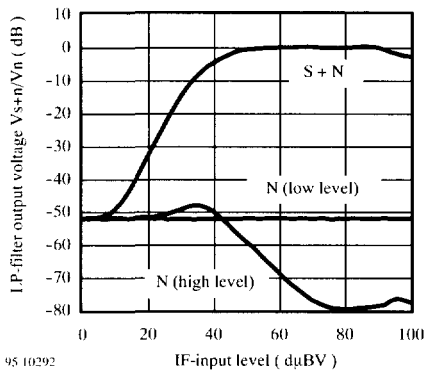
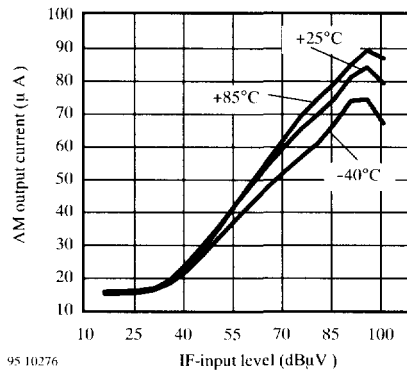

Figure 23. AM test circuit with 2-kHz Bessel lowpass data filter



95 10292

Figure 24. Signal-to-noise ratio AM



95 10276

Figure 25. AM-demodulator characteristic vs. temperature

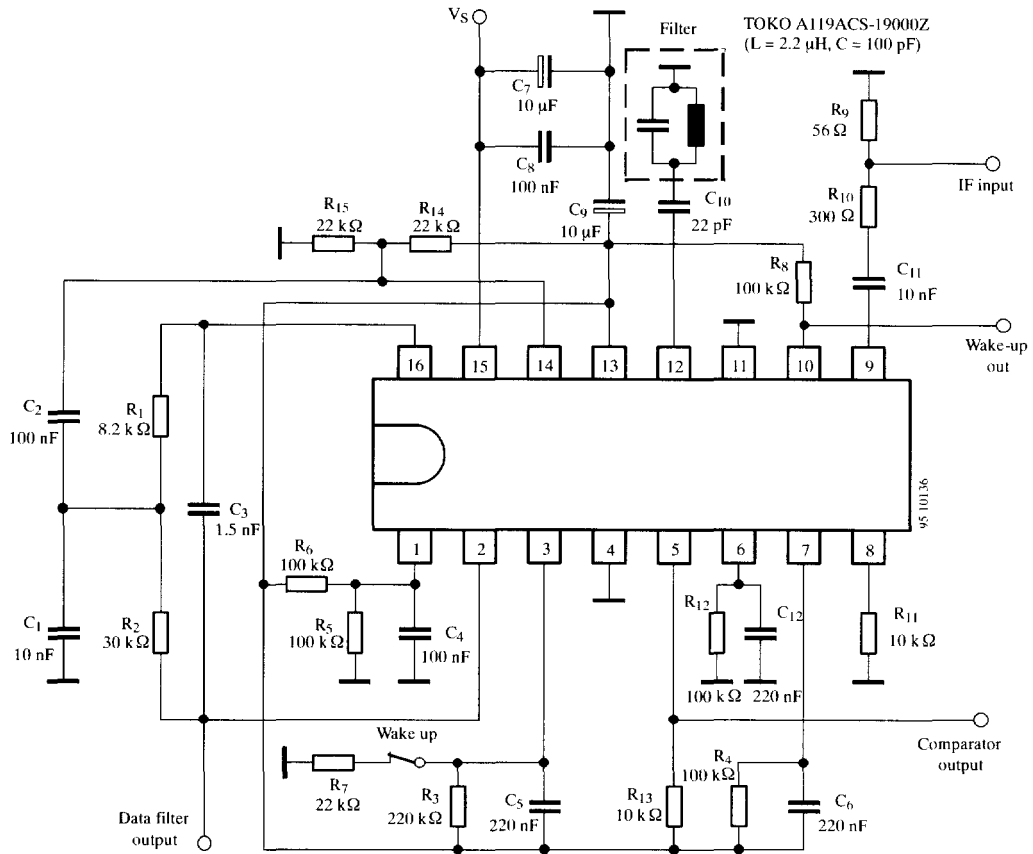

Figure 26. FM test circuit with 2-kHz Bessel lowpass data filter

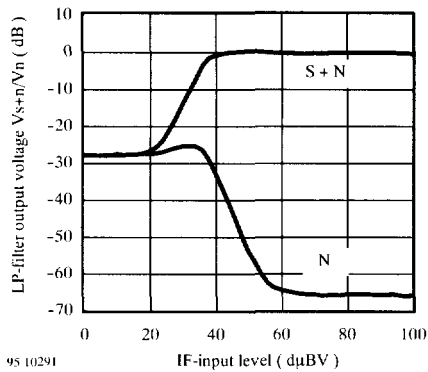

Figure 27. Signal-to-noise ratio FM: deviation 22.5 kHz

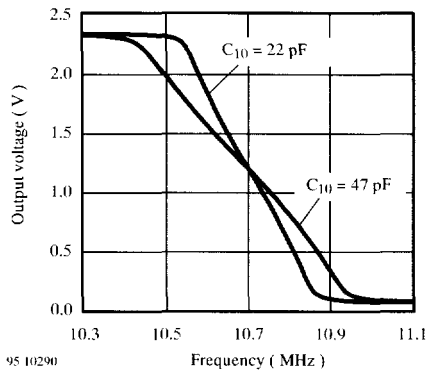

Figure 28. FM-discriminator characteristic

## Application

The U4311B is well-suited to implement UHF remote control or data transmission systems, based on a low-current superheterodyne receiver concept. SAW-devices may be used in the transmitter's as well as in the receiver local oscillator. The front end should be a discrete circuit application with low-current UHF transistors such as S822T or S852T (Vishay Telefunken). The frequency of the local oscillator can be determined either by coaxial resonators or SAW devices. Due to large

SAW-resonator tolerance, an IF bandwidth – and in a FM system additionally the discriminator amplitude characteristic (figure 28) – of 300 kHz or higher is proposed. As the circuit needs only 3.0 V supply voltage for operation, the front end may be a stacked design in order to achieve a total receiver current consumption of approximately 1 mA. Figure 29 shows a principle receiver concept diagram.

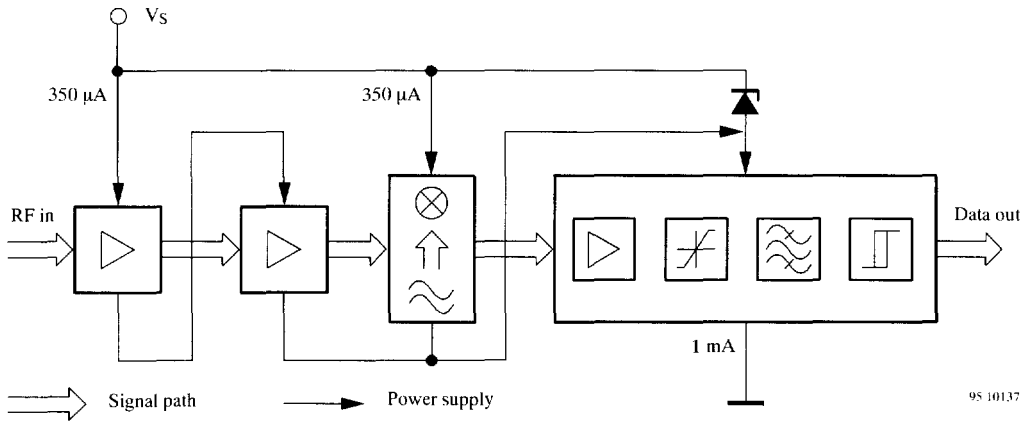
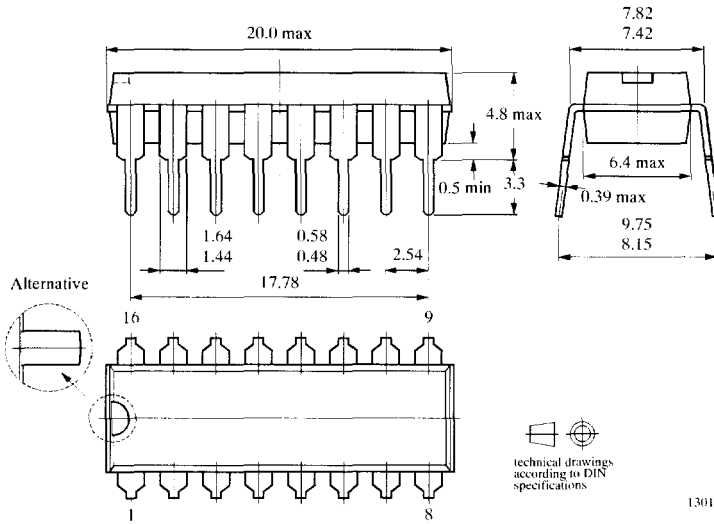

Figure 29. Principle diagram of a UHF remote control receiver

**Package Information**

Package DIP16  
Dimensions in mm



Package SO16L  
Dimensions in mm

