

6

5

4

3

2

1

APPROVED: _____
 DATE: _____ TITLE: _____

Rev	AWO #	Description	Date	Appr
1	AN15566	PRELIMINARY	04/14/20	
2	AN15566	ADDED PACKING	4/30/20	LH/TW

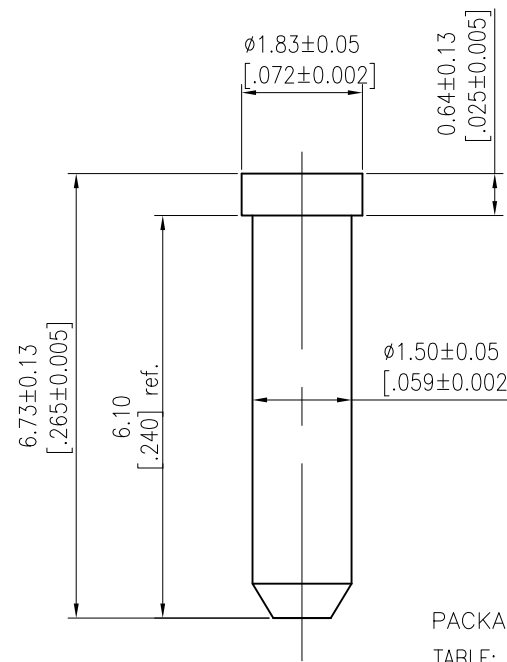
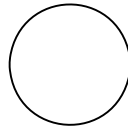

PACKAGED ON TAPE & REEL; 1,170pcs per 13" Reel
 TABLE:

ADT-AN15566-3-T-T/R	200u" Tin over Nickel
ADT-AN15566-3-G-T/R	10u" Gold over Nickel
PART NUMBER	PLATING

SPECIFICATIONS:
 Material: Brass
 Plating: See Table
 Temperature Rating: Operating temperature: -55°C to +125°C
 Environmental: Lead free, RoHS compliant



UNLESS OTHERWISE SPECIFIED ALL DIMENSIONS ARE MM [INCHES] TOLERANCES: EXCEPT AS NOTED		
MM	ANGLE	
X.X ± 0.38	X. ±5°	
X.XX ± 0.20	X.X ±2°	
X.XXX ± 0.10	X.XX ±1°	
APPROVALS		DATE
DRAWN	OW	04/14/20
CHECKED	TW	04/14/20
APPROVED		

ADAM TECH
 INTERCONNECTS
 909 Rahway Avenue,
 Union, NJ 07083
 Phone: 908-687-5000
 Fax: 908-687-5710

TITLE PIN 1.50 X L6.73MM, REEL PACKAGE		
SIZE X	PART NO. ADT-AN15566-3-X-T/R	REV. 2
REF: S00181C	SCALE: NTS	SHEET 1 OF 1

6

5

4

3

2

1

Rev	AWO #	Description	Date	Appr
PACKAGED ON TAPE & REEL				

APPROVED: _____

DATE: _____ TITLE: _____

PULL OUT DIRECTION REEL LABEL →

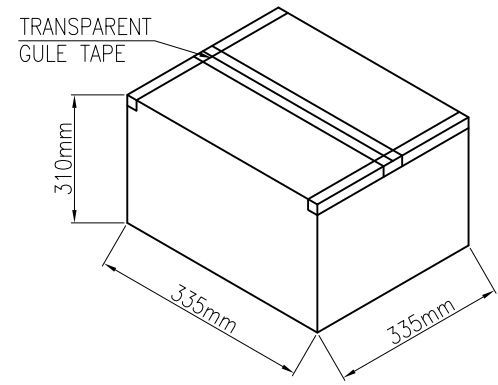
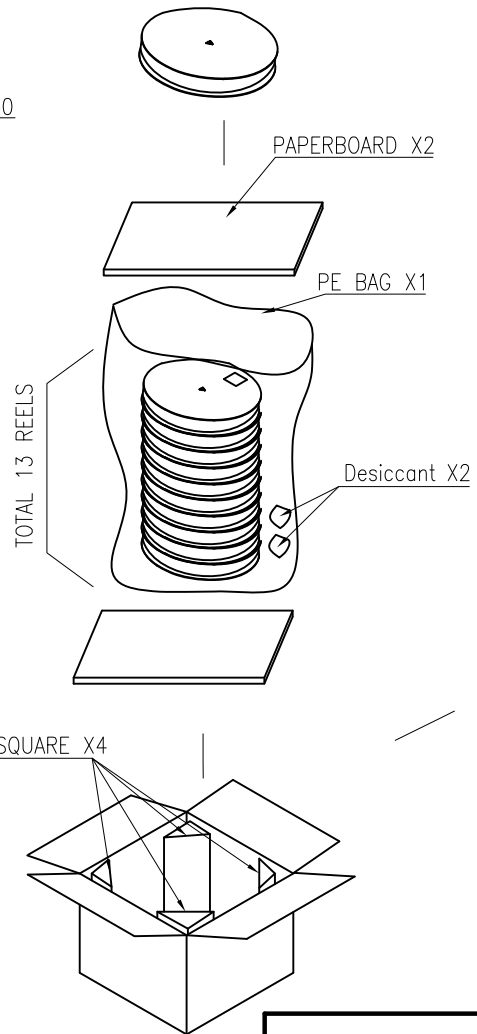
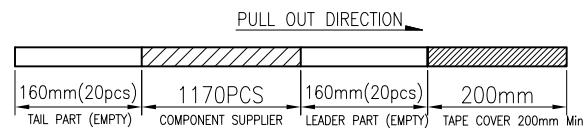
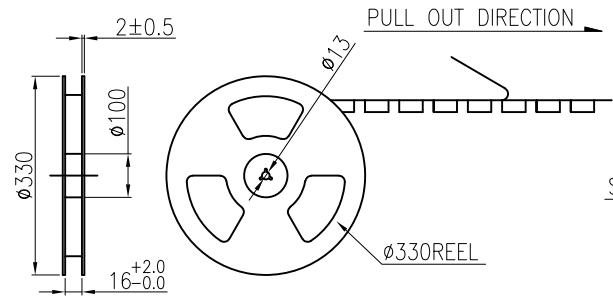
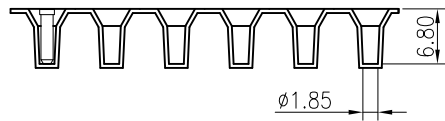
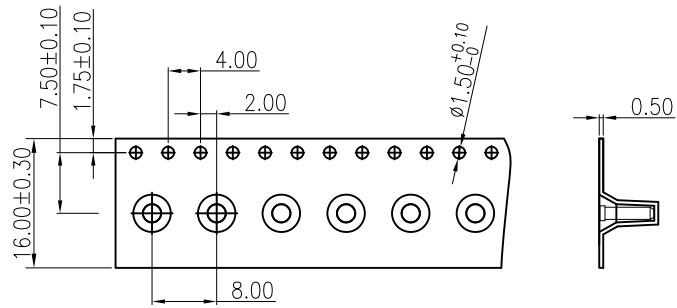

- NOTES:
- MATERIAL:
 - TAPE:PS,T=0.50±0.05mm,BLACK,ESD
 - REEL:PS,
 - COVER TAPE:PE,CLEAR.
 - PRIMARY PACKING:1170PCS/REEL.
 - SECONDARY PACKING:15210PCS/13REEL/CARTON
 - PEELING RESISTANCE: 0.2N(20gf)MIN; PEELING ANGLE: 165°~180°; PEELING SPEED: 300mm/minutes.

UNLESS OTHERWISE SPECIFIED ALL DIMENSIONS ARE MM [INCHES] TOLERANCES: EXCEPT AS NOTED	
MM	ANGLE
X.X ± 0.38	X. ±5°
X.XX ± 0.20	X.X ±2°
X.XXX ± 0.10	X.XX ±1°
APPROVALS	
DRAWN	DATE
CHECKED	DATE
APPROVED	

ADAM TECH INTERCONNECTS 909 Rahway Avenue, Union, NJ 07083
Phone: 908-687-5000 Fax: 908-687-5710

TITLE: PIN 1.50 X L6.73MM, REEL PACKAGE

SIZE X	PART NO. ADT-AN15566-3-X-T/R	REV. 2
REF: S00181C	SCALE: NTS	SHEET 1 OF 1

6 5 4 3 2 1

D

D

C

C

B

B

A

A

6 5 4 3 2 1