

Helping Customers Innovate, Improve & Grow



Description

Vectron's VCC6 Crystal Oscillator is a quartz stabilized, differential output oscillator, operating off either a 2.5 or 3.3 volt supply, hermetically sealed 5x7 ceramic package.

Features

- Ultra Low Jitter Performance, Fundamental or 3rd OT Crystal Design
- Output Frequencies to 350.000MHz
- 0.3 ps typical RMS jitter, 12k-20MHz
- Differential Output
- Enable/Disable
- -10/70°C, -40/85°C or -55/125°C Operation
- Hermetically Sealed 5x7 Ceramic Package
- Product is compliant to RoHS directive  and fully compatible with lead free assembly

Applications

- Ethernet, GbE, Synchronous Ethernet
- Fiber Channel
- Enterprise Servers
- Telecom
- Clock source for A/D's, D/A's
- Driving FPGA's
- Test and Measurement
- PON
- Medical
- COTS

Block Diagram

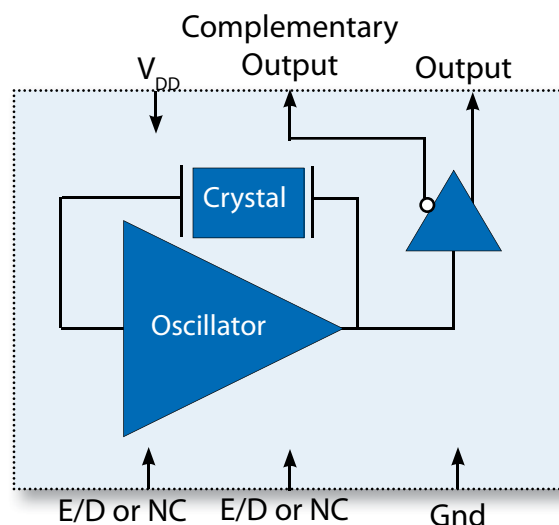

Performance Specifications

Table 1. Electrical Performance, LVPECL Option

Parameter	Symbol	Min	Typical	Maximum	Units	
Supply						
Voltage ¹	V_{DD}	3.135	3.3	3.465	V	
		2.375	2.5	2.625	V	
Current (No Load)	I_{DD}		50	98	mA	
Frequency						
Nominal Frequency ²	f_N	25		350.000	MHz	
Stability ^{2,3} (Ordering Option)		±20, ±25, ±50, ±100			ppm	
Outputs						
Output Logic Levels ⁴ , -10/70°C	V_{OH} V_{OL}	$V_{DD}-1.025$		$V_{DD}-0.880$	V	
		$V_{DD}-1.810$		$V_{DD}-1.620$	V	
Output Logic Levels ⁴ , -40/85°C	V_{OH} V_{OL}	$V_{DD}-1.085$		$V_{DD}-0.880$	V	
		$V_{DD}-1.830$		$V_{DD}-1.555$	V	
Output Rise and Fall Time ⁴	t_R/t_F			600	ps	
Load		50 ohms into $V_{DD}-1.3V$				
Duty Cycle ⁵		45	50	55	%	
Jitter (12 kHz - 20 MHz BW) 155.52MHz ⁶	ϕJ		0.3	0.7	ps	
Period Jitter ⁷	ϕJ					
			RMS		2.3	ps
			P/P		20	ps
			Random Jitter		2.4	ps
Deterministic Jitter		0	ps			
Enable/Disable						
Output Enabled ⁸	V_{IH}	$0.7*V_{DD}$			V	
Output Disabled	V_{IL}			$0.3*V_{DD}$	V	
Disable Time	t_D			200	ns	
Enable/Disable Leakage Current				±200	uA	
Enable Pull-Up Resistor						
			Output Enabled	33	KOhm	
Output Disabled	1	MOhm				
Start-Up Time	t_{SU}			10	ms	
Operating Temp. (Ordering Option)	T_{OP}	-10/70 or -40/85			°C	
Package Size		5.0 x 7.0 x 1.8 or 5.08x7.5x2.2			mm	

1. The VCC6 power supply pin should be filtered, eg, a 0.1 and 0.01uf capacitor.
2. See Standard Frequencies and Ordering Information for more information.
3. Includes calibration tolerance, operating temperature, supply voltage variations, aging and IR reflow.
4. Figure 1 defines the test circuit and Figure 2 defines these parameters.
5. Duty Cycle is defined as the On/Time Period.
6. Measured using an Agilent E5052, 155.520MHz. Please see "Typical Phase Noise and Jitter Report for the VCC6 series".
7. Measured using a Wavcrest SIA3300C, 90K samples.
8. Outputs will be Enabled if Enable/Disable is left open.

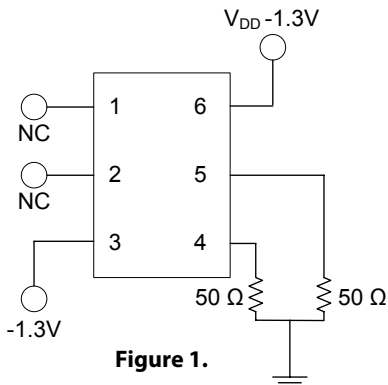

Figure 1.

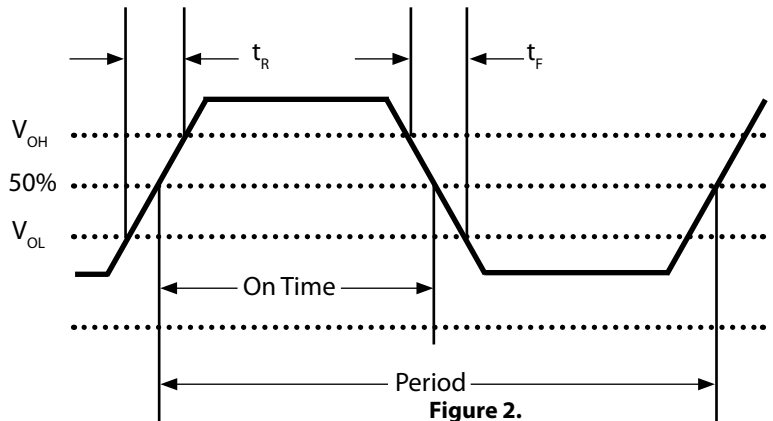

Figure 2.

Performance Specifications

Table 2. Electrical Performance, LVDS Option					
Parameter	Symbol	Min	Typical	Maximum	Units
Supply					
Voltage ¹	V_{DD}	3.135 2.375	3.3 2.5	3.465 2.625	V V
Current (No Load)	I_{DD}			60	mA
Frequency					
Nominal Frequency ²	f_N	80		350.000	MHz
Stability ^{2,3} (Ordering Option)		±20, ±25, ±50, ±100			ppm
Outputs					
Output Logic Levels ⁴					
Output Logic High	V_{OH}		1.43	1.6	V
Output Logic Low	V_{OL}	0.9	1.10		V
Differential Output Amplitude		247	330	454	mV
Differential Output Error				50	mV
Offset Voltage		1.125	1.25	1.375	V
Offset Voltage Error				50	mV
Output Leakage Current				10	uA
Output Rise and Fall Time ⁴	t_R/t_F			600	ps
Load		100 ohms differential			
Duty Cycle ⁵		45	50	55	%
Jitter (12 kHz - 20 MHz BW) 155.52MHz ⁶	ϕJ		0.3	0.7	ps
Period Jitter ⁷	ϕJ				
RMS			2.5		ps
P/P			22		ps
Random Jitter			2.6		ps
Deterministic Jitter			0		ps
Enable/Disable					
Output Enabled ⁸	V_{IH}	$0.7 \cdot V_{DD}$			V
Output Disabled	V_{IL}			$0.3 \cdot V_{DD}$	V
Disable Time	t_D			200	ns
Enable/Disable Leakage Current				±200	uA
Enable Pull-Up Resistor					
Output Enabled			33		KOhm
Output Disabled			1		MOhm
Start-Up Time	t_{SU}			10	ms
Operating Temp. (Ordering Option)	T_{OP}	-10/70 or -40/85			°C
Package Size		5.0 x 7.0 x 1.8 or 5.08x7.5x2.2			mm

1. The VCC6 power supply pin should be filtered, eg, a 0.1 and 0.01uf capacitor.
2. See Standard Frequencies and Ordering Information for more information.
3. Includes calibration tolerance, operating temperature, supply voltage variations, aging and IR reflow.
4. Figure 2 defines these parameters and Figure 3 defines the test circuit.
5. Duty Cycle is defined as the On/Time Period.
6. Measured using an Agilent E5052, 155.520MHz. Please see "Typical Phase Noise and Jitter Report for the VCC6 series".
7. Measured using a Wavecrest SIA3300C, 90K samples.
8. Outputs will be Enabled if Enable/Disable is left open.

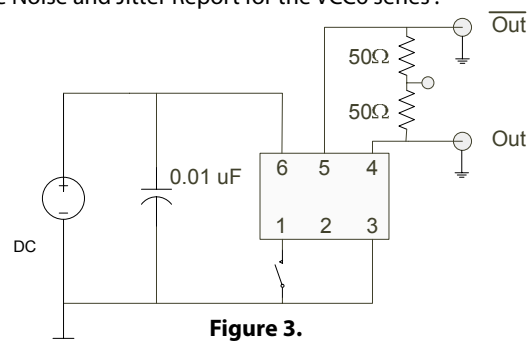

Figure 3.

Package and Pinout

Table 3. Pinout

Pin #	Symbol	Function
1	E/D or NC	Enable Disable or No Connection
2	E/D or NC	Enable Disable or No Connection
3	GND	Electrical and Lid Ground
4	f_o	Output Frequency
5	Cf_o	Complementary Output Frequency
6	V_{DD}	Supply Voltage

The Enable/Disable function is set at the factory on either pin 1 or pin 2 and is an ordering option. Outputs will be Enabled if the Enable/Disable is left open.

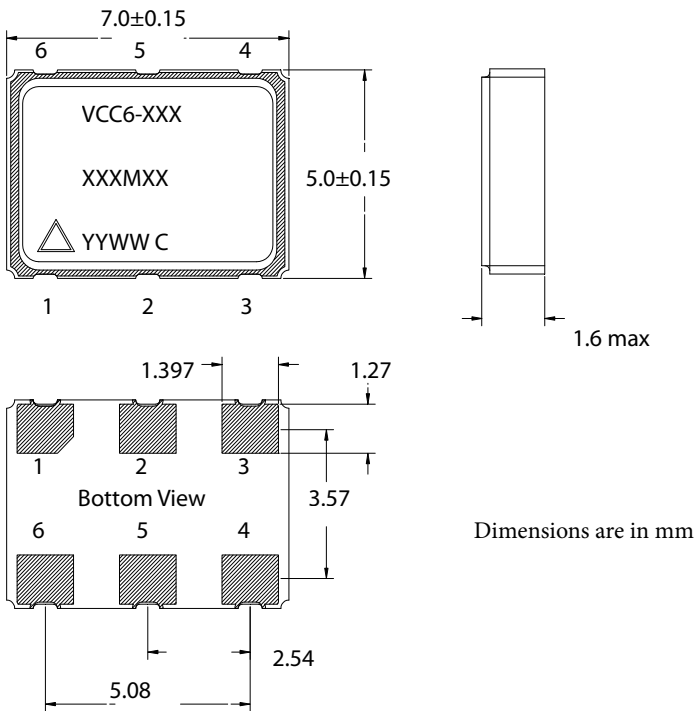

Figure 4. Package A Outline Drawing

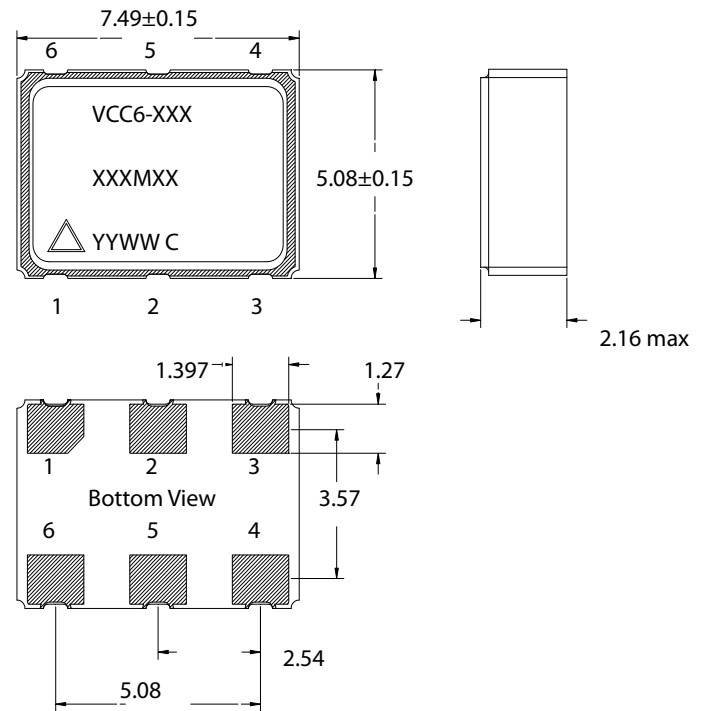

Figure 5. Optional Package Outline Drawing

The VCC6 can be supplied in one of two package options and Figure 4 shows the primary package used. The pad layout and dimensions are identical and a reel would include only 1 of the two options.

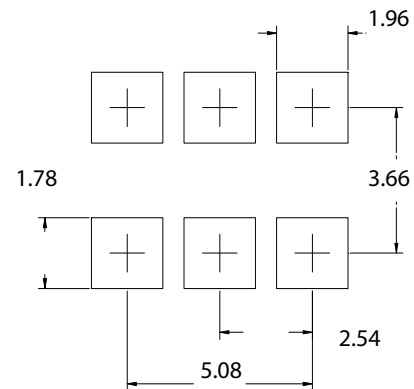

Figure 6. Pad Layout

LVPECL Application Diagrams

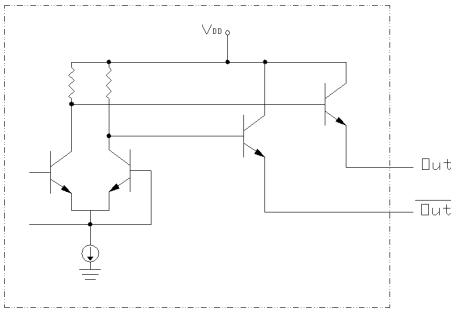

Figure 7. Standard PECL Output Configuration

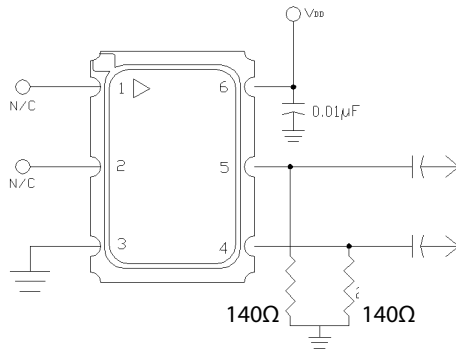

Figure 8. Single Resistor Termination Scheme
Resistor values are typically 140 ohms for 3.3V operation.
Resistor values are typically 84 ohms for 2.5V operation.

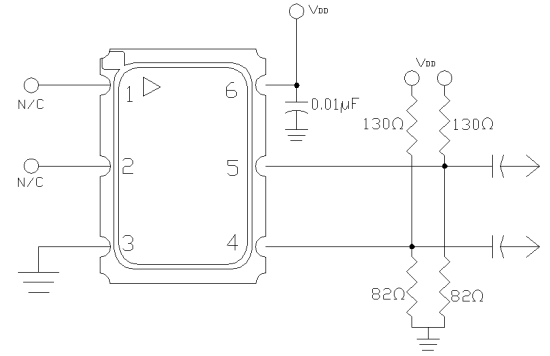

Figure 9. Pull-Up Pull Down Termination
Resistor values are typically for 3.3V operation
For 2.5V operation, the resistor to ground is 62 ohms and the resistor to supply is 240 ohms

The VCC6 incorporates a standard PECL output scheme, which are un-terminated emitters as shown in Figure 7. There are numerous application notes on terminating and interfacing PECL logic and the two most common methods are a single resistor to ground, Figure 8, and a pull-up/pull-down scheme as shown in Figure 9. An AC coupling capacitor is optional, depending on the application and the input logic requirements of the next stage.

LVDS Application Diagrams

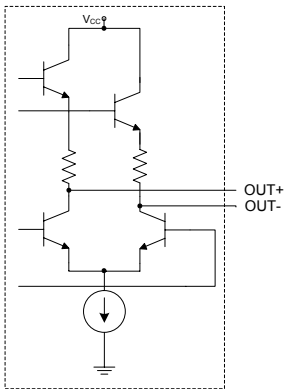

Figure 10 Standard LVDS Output Configuration

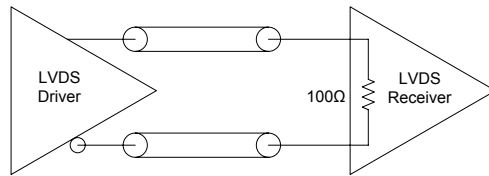

Figure 11. LVDS to LVDS Connection, Internal 100ohm
Some LVDS structures have an internal 100 ohm resistor on the input and do not need additional components.

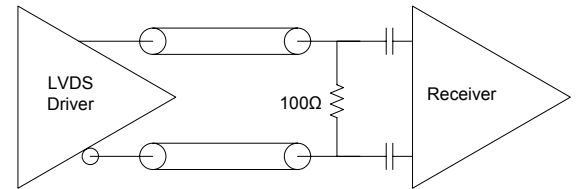

Figure 12. LVDS to LVDS Connection External 100ohm and AC blocking caps
Some input structures may not have an internal 100 ohm resistor on the input and will need an external 100ohm resistor for impedance matching. Also, the input may have an internal DC bias which may not be compatible with LVDS levels, AC blocking capacitors can be used.

One of the most important considerations is terminating the Output and Complementary Outputs equally. An unused output should not be left un-terminated, and if one of the two outputs is left open it will result in excessive jitter on both. PC board layout must take this and 50 ohm impedance matching into account. Load matching and power supply noise are the main contributors to jitter related problems.

Environmental and IR Compliance

Table 4. Environmental Compliance	
Parameter	Condition
Mechanical Shock	MIL-STD-883 Method 2002
Mechanical Vibration	MIL-STD-883 Method 2007
Temperature Cycle	MIL-STD-883 Method 1010
Solderability	MIL-STD-883 Method 2003
Fine and Gross Leak	MIL-STD-883 Method 1014
Resistance to Solvents	MIL-STD-883 Method 2015
Moisture Sensitivity Level	MSL1
Contact Pads	Gold over Nickel

IR Compliance

Suggested IR Profile

Devices are built using lead free epoxy and can be subjected to standard lead free IR reflow conditions shown in Table 5. Contact pads are gold over nickel and lower maximum temperatures can also be used, such as 220C.

Parameter	Symbol	Value
PreHeat Time	t_s	200 sec Max
Ramp Up	R_{UP}	3°C/sec Max
Time above 217°C	t_L	150 sec Max
Time to Peak Temperature	t_{AMB-P}	480 sec Max
Time at 260°C	t_P	30 sec Max
Time at 240°C	t_{P2}	60 sec Max
Ramp down	R_{DN}	6°C/sec Max

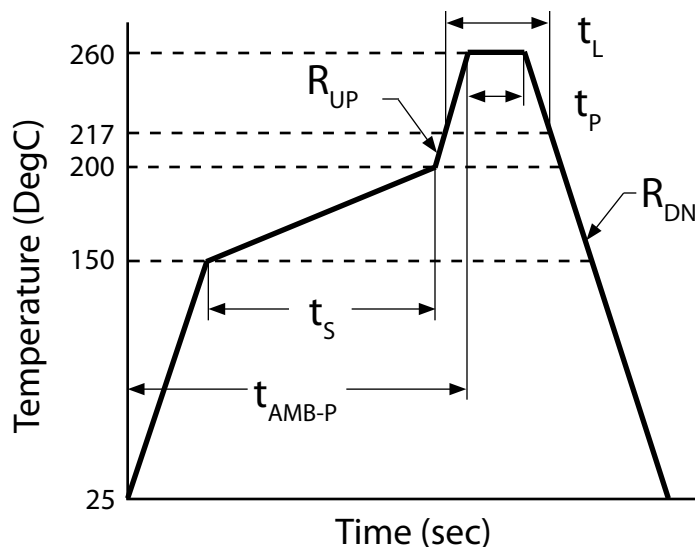

Maximum Ratings, Tape & Reel

Absolute Maximum Ratings and Handling Precautions

Stresses in excess of the absolute maximum ratings can permanently damage the device. Functional operation is not implied or any other excess of conditions represented in the operational sections of this data sheet. Exposure to absolute maximum ratings for extended periods may adversely affect device reliability.

Although ESD protection circuitry has been designed into the VCC6, proper precautions should be taken when handling and mounting. VI employs a Human Body Model and Charged Device Model for ESD susceptibility testing and design evaluation. ESD thresholds are dependent on the circuit parameters used to define the model. Although no industry standard has been adopted for the CDM a standard resistance of 1.5kOhms and capacitance of 100pF is widely used and therefor can be used for comparison purposes.

Parameter	Symbol	Rating	Unit
Storage Temperature	T_{STORE}	-55/125	°C
Supply Voltage		-0.5 to 5.0	V
Enable/Disable Voltage		-0.5 to $V_{DD}+0.5$	V
ESD, Human Body Model		1500	V
ESD, Charged Device Model		1000	V

Table 7. Tape and Reel Information

Tape Dimensions (mm)					Reel Dimensions (mm)							
W	F	Do	Po	P1	A	B	C	D	N	W1	W2	#/Reel
16	7.5	1.5	4	8	180	2	13	21	55	17	21	250

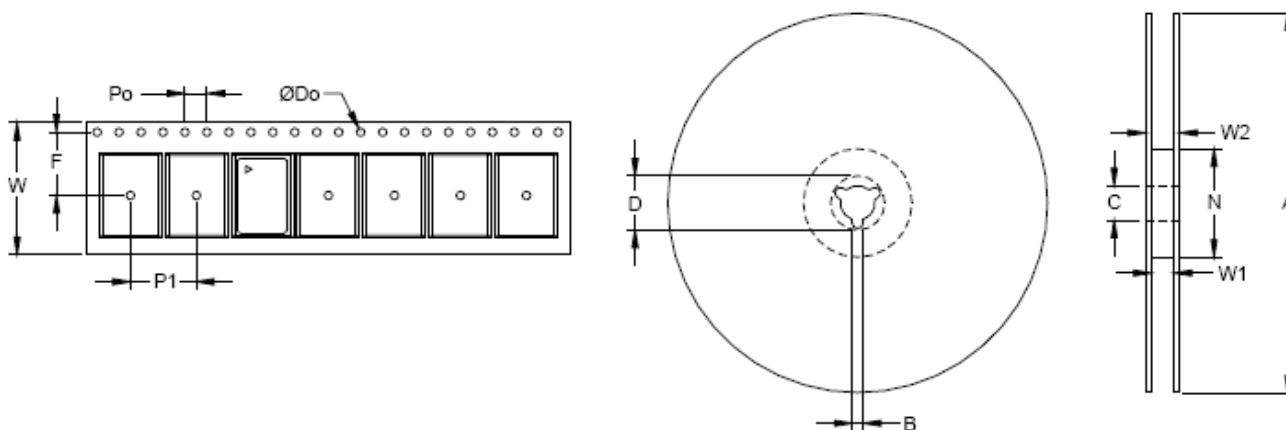

Table 8. Standard Frequencies (MHz)

19.4400	25.0000	27.1200	30.7200	33.0000	33.3330	35.0000	35.5000	38.8800	40.0000	40.6800
43.7500	48.0000	50.0000	53.1250	56.0000	61.4400	62.2080	62.5000	66.0000	68.0000	70.0000
71.5000	74.1758	74.2500	75.0000	75.4000	77.7600	78.1250	80.0000	81.2500	83.3330	84.0000
86.0000	87.5000	90.0000	95.0000	99.1440	100.0000	105.0000	106.2500	110.0000	112.0000	112.5000
114.2850	120.0000	122.8800	124.4160	125.0000	125.0093	128.0000	130.0000	130.5882	132.8125	133.0000
135.0000	136.0000	140.0000	142.5408	143.0000	148.7500	150.0000	153.6000	153.8500	155.5200	156.1734
156.2500	156.253906	156.261718	156.2740	156.2930	159.3750	160.0000	161.1300	161.1328	162.3250	164.3555
165.0000	166.0000	166.5600	166.6286	166.6667	167.3300	167.3317	167.328125	167.4100	168.2009	168.6997
172.6423	173.3700	173.3708	173.4380	175.0000	176.0950	176.8382	177.3437	178.018970	178.1250	178.5000
180.0000	187.0177	187.5000	190.0000	192.4560	195.3125	200.0000	210.0000	212.4840	212.5000	218.7500
225.0000	250.0000	260.0000	266.0000	275.0000	287.5000	312.5000				

Ordering Information

VCC6 - X X X - XXMXXXXXX

Product

XO, 5x7 Package

Output and Voltage

Q: +3.3 Vdc ±5%, LVPECL
 R: +2.5 Vdc ±5%, LVPECL
 L: +3.3 Vdc ±5%, LVDS
 V: +2.5 Vdc ±5%, LVDS

Enable/Disable

A: E/D is on Pin 2
 C: E/D is on Pin 1

Frequency in MHz

Stability/Temp Range

A: ±100 ppm over -10/70°C
 B: ±50 ppm over -10/70°C
 C: ±100 ppm over -40/85°C
 D: ±50 ppm over -40/85°C
 E: ±25 ppm over -10/70°C
 F: ±25 ppm over -40/85°C
 G: ±20 ppm over -10/70°C, excludes aging
 P: ±100 ppm over -55/125°C

**Note: not all combination of options are available.
 Other specifications may be available upon request.*

±20ppm Options

VCC6-107-frequency	LVPECL	+3.3V	±20ppm over -10/70°C, includes 10 years aging, E/D on Pin1
VCC6-109-frequency	LVDS	+3.3V	±20ppm over -10/70°C, includes 10 years aging, E/D on Pin1
VCC6-110-frequency	LVPECL	+2.5V	±20ppm over -10/70°C, includes 10 years aging, E/D on Pin1
VCC6-111-frequency	LVDS	+2.5V	±20ppm over -10/70°C, includes 10 years aging, E/D on Pin1
VCC6-119-frequency	LVPECL	+3.3V	±20ppm over -40/85°C, includes 10 years aging, E/D on Pin1
VCC6-120-frequency	LVPECL	+2.5V	±20ppm over -40/85°C, includes 10 years aging, E/D on Pin1
VCC6-121-frequency	LVDS	+3.3V	±20ppm over -40/85°C, includes 10 years aging, E/D on Pin1
VCC6-122-frequency	LVDS	+2.5V	±20ppm over -40/85°C, includes 10 years aging, E/D on Pin1

For Additional Information, Please Contact

USA:

Vectron International
 267 Lowell Road Unit 102
 Hudson, NH 03051
 Tel: 1.888.328.7661
 Fax: 1.888.329.8328

Europe:

Vectron International
 Landstrasse, D-74924
 Neckarbischofsheim, Germany
 Tel: +49 (0) 3328.4784.17
 Fax: +49 (0) 3328.4784.30

Asia:

Vectron International
 68 Yin Cheng Road(C), 22nd Floor
 One LuJiaZui
 Pudong, Shanghai 200120, China
 Tel: 86.21.6194.6886
 Fax: 86.21.6194.6699

Disclaimer

Vectron International reserves the right to make changes to the product(s) and or information contained herein without notice. No liability is assumed as a result of their use or application. No rights under any patent accompany the sale of any such product(s) or information.