

PTCR Motor Start Packages PSC Single Phase Motor Start Assist

ECONOMICAL SOLID STATE TORQUE ASSIST FOR HEAT PUMPS, ROOM AIR, COMMERCIAL AND RESIDENTIAL AIR CONDITIONING AND REFRIGERATION SYSTEMS

Positive Temperature Coefficient Resistors have been used for many years in millions of HVAC applications to provide starting torque assistance to Permanent Split Capacitor (PSC) single phase compressor motors.

Sizes are available to cover the full range of 120/240 volt PSC compressor motors.

Safety Agency Recognition

Vishay Cera-Mite motor start PTCRs are recognized by Underwriter Laboratories file E97640 in accordance with Standard for Thermistor Type Devices UL 1434; and Canadian Standards C22.2 No. 0-1991. All packages and accessories are RoHS compliant.

RELATIVE COMPARISON OF VARIOUS MOTOR STARTING METHODS

Three methods have historically been employed to generate starting torque for PSC motors. All are well-proven technologies and may be compared relative to one another based upon categories shown below.

The importance of each category is dependent upon the motor application and industry sector. In general, if the PTCR starter produces sufficient starting torque, it is considered the simplest and most economical choice.

Table 1

STARTING METHOD	MECHANICAL			ELECTRICAL					FINANCIAL		
	EASE OF WIRING	PANEL SPACE REQUIRED	SENSITIVE TO MOUNTING DIRECTION	ACCELERATION TORQUE PRODUCED	ACCELERATION (SWITCH) TIME	RESET TIME REQUIRED	EMI/RFI GENERATED	TECHNOLOGY	INVENTORY MIX REQUIRED	RELIABILITY	PURCHASED COST
PTCR Starter	Simple 2 Wire	Lowest	No	Lowest	Fixed	3 - 5 Minutes	No	Solid State	Lowest	Highest	Lowest
Start Cap with PTCR Acting as A Current Relay	Moderate 2 or 3 Wire	Medium	Yes	Medium	Fixed	2 - 5 Minutes	No	Solid State	Medium	Medium	Medium
Start Cap used With Potential or Current Relay	Difficult 4 or 5 Wire	Highest	Yes	Highest	Variable Based on Motor Speed	None	Yes	Electro Mechanical	Highest	Lowest	Highest

SIMPLIFIED PTCR STARTING DIAGRAM

Start Sequence. When starting the compressor, contactor (M) closes; the PTCR, which is at low resistance, provides starting current to the motor’s auxiliary winding. After time delay (t), the current passing through the PTCR causes it to heat and “switch” to a very high resistance. At this point the motor is up to speed and the run capacitor (C_R) determines the current in the auxiliary winding. The PTCR remains hot and at high resistance as long as voltage remains on the circuit. When contactor (M) opens, shutting off voltage to the compressor, the PTCR cools to its initial low resistance and is again ready to provide torque assist on the next startup.

Restart. It is important to provide time between motor starts to allow the PTCR to cool to near its initial temperature. This time is usually 3 to 5 minutes and is determined by the thermostat (THERM) or separate time-delay relay (TR). Attempts to restart in less time may be successful depending on compressor equalization, line voltage, temperature, and other conditions. If the motor were to stall in a locked-rotor state, overload device (PD or TS) would open the line and a further time delay would occur until the motor overload is reset. Motor start PTCRs are applied to compressors having means to equalize pressure during shutdown.

Fig T-2

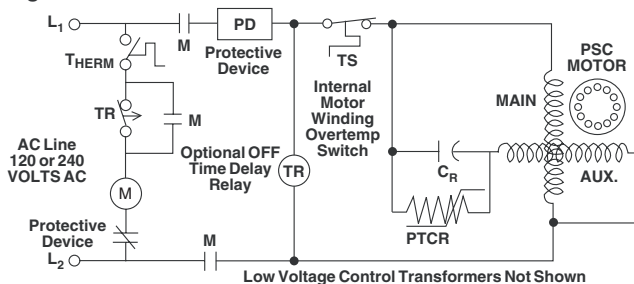

TYPICAL PTCR CHARACTERISTICS AS A MOTOR START DEVICE

Fig T-3

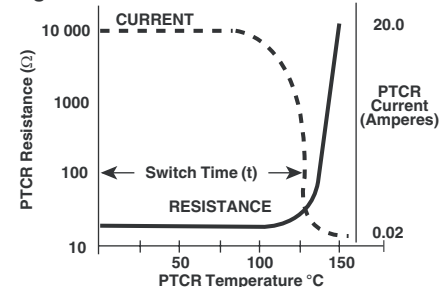

START AND ACCELERATION TORQUES SINGLE PHASE PSC HIGH EFFICIENCY COMPRESSORS

The use of a PTCR start assist insures sufficient acceleration torque to overcome not only breakaway friction, but also parasitic asynchronous torques associated with the 5th and 7th motor harmonics or lamination slot harmonics.

ACCELERATION TIME CONSIDERATIONS

The time to accelerate a rotating machine is:

$$\text{Accelerating Time (Seconds)} = \frac{\text{RPM} \times \text{WK}^2 (\text{lb ft}^2)}{\text{Avg. Torque (lb ft)} \times 308}$$

(Avg. Torque = Curve B - Curve A)

1. If (Curve B - Curve A) is zero or less, the motor may stall.
2. In calculating torque available from Curve B, allowance should be made for cusps in the torque curve due to harmonics. The time needed to accelerate from rest to 1/2 speed is critical, as the average torque available in this region is limited. Select a PTCR with sufficient switching time (t) to accelerate the compressor.
3. Scroll and rotary compressors may have less breakaway torque than shown.
4. A compressor with no equalization may require over 100 % starting torque and time as long as several seconds. PTCR starters not recommended.

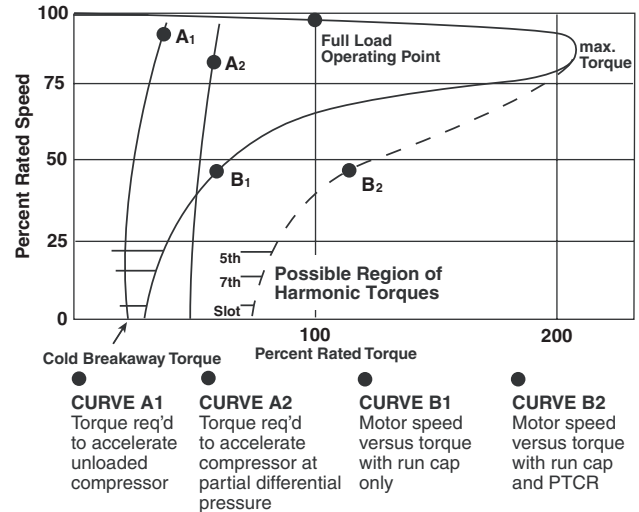

CONSIDERATIONS FOR CURRENT IN PTCR APPROXIMATE EQUIVALENT CIRCUIT PSC MOTOR AT ZERO SPEED

$$I_L(\text{run}) = \frac{\text{HP} \times 746}{V_M \times \text{pf} \times \text{eff}} \quad I_L(\text{start}) \approx I_L(\text{run})$$

For running conditions:

$$\text{If } V_{\text{aux}} = V_M \text{ then } I_M \text{ and } I_{\text{aux}} = \frac{I_L}{\sqrt{2}}$$

$$\text{If } (V_{\text{aux}} \neq V_M) \text{ then } I_{\text{aux}} = \frac{I_L}{\sqrt{2}} \times \frac{V_M}{V_{\text{aux}}} \text{ and } Z_{\text{aux}} = \frac{V_M}{I_{\text{aux}}}$$

For the greatest starting torque, PTCR should be chosen to make:

$V_M \times I_M = V_{\text{aux}} \times I_{\text{aux}}$. In many cases the auxiliary Volt-Amperes are limited to about 50 % of the main winding Volt-Amperes to get 50 % - 70 % rated torque.

Then at start, with PTCR in series: $Z'_{\text{aux}} = R_{\text{PTCR}} + Z_{\text{aux}}$

$$I_{R\text{start}} \text{ through PTCR} = \frac{V_M}{Z_{\text{aux}}}$$

$$I_{C\text{start}} \text{ through Run Cap} = \frac{V_M}{X_C}; \quad X_C = \frac{1}{2\pi f C} \Omega$$

$$I_{\text{aux start}} = I_{R\text{start}} + I_{C\text{start}}$$

If Z_{aux} is low impedance, less than 10 % of R_{PTCR}

then it can be ignored and $I_{\text{PTCR at start}} = \frac{V_M}{R_{\text{PTCR}}}$

This closely approximates the condition for motors over 1/2 HP.

Fig T-5
Fig T-5

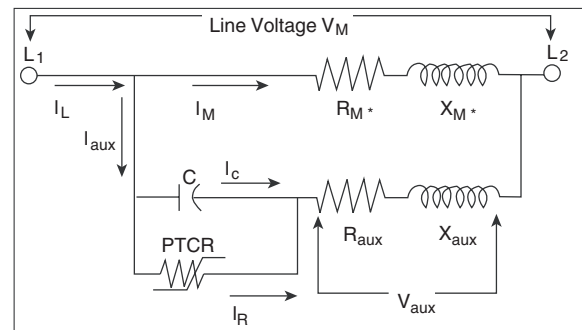

*R and X are total of stator and rotor

Fig T-6

Simplified Voltage Diagram of the PSC Motor at Operating Speed

* I_A (auxiliary current) leads I_M (main current) by 80° to 90° when C (run capacitor) is chosen for balanced operation at 3/4 to full load. Line Power Factor = $\sin 2\theta$

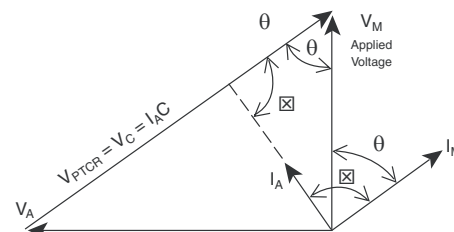

EFFECT OF PTC RESISTANCE ON STARTING TORQUE OF PSC MOTORS

Table 2

MOTOR HP (TABLE 4) (NOTE 7)	LOCKED ROTOR TORQUE WITH RUN CAP ONLY % RATED TORQUE (SEE A)	STARTING TORQUE WITH RUN CAP AND PTCR (% RATED TORQUE) (SEE B) RESISTANCE (RDYN)				
		50 Ω	25 Ω	20 Ω	12.5 Ω	10 Ω
0.5	25 % to 35 %	70 - 100 %	80 - 100 %	NA	NA	NA
1	25 % to 35 %	50 - 70 %	70 - 100 %	NA	NA	NA
2	20 % to 30 %	40 - 60 %	60 - 90 %	70 - 100 %	70 - 100 %	80 - 100 %
3.5	20 % to 30 %	NA	40 - 60 %	50 - 85 %	60 - 90 %	70 - 100 %
5	15 % to 25 %	NA	NA	40 - 60 %	50 - 75 %	60 - 90 %
6.5	15 % to 25 %	NA	NA	NA	40 - 70 %	50 - 80 %

A. Rated torque is the torque at full speed rated load.

It is calculated as:

$$\text{Torque (lb-ft)} = \frac{\text{HP} \times 5250}{\text{RPM}}$$

The range shown includes both normal slip and high efficiency low slip motors. Starting torque varies as: (Line Voltage)².

B. Figure T-4 shows effect of using PTCR to increase starting torque. For reciprocating compressors, it is advised to choose a resistance value that gives at least 50 % rated torque at locked rotor. Scroll and rotary compressors may require less torque.

TYPICAL PTCR CURRENT VS. TIME SHOWING DEFINITION OF RDYN AND SWITCH TIME (T)

Fig T-7

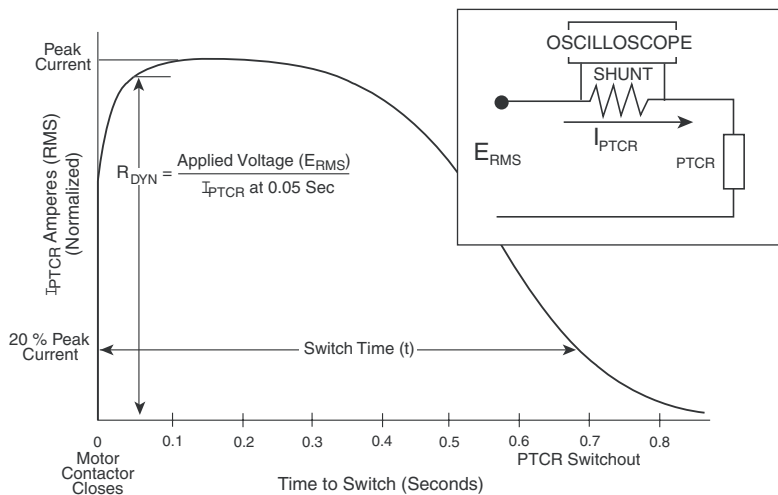

$$\text{Time (t)} \approx KM (130^\circ\text{C} - T_0) \frac{R_{DYN}}{V_{PTCR}^2}$$

M = PTCR mass
 T₀ = PTCR temp at time 0
 K = 0.75 J/g/°C

START CAPACITOR REPLACEMENT

Capacitor Starting Comparison

Some PSC motors have historically been started with a capacitor and relay. To deliver the same starting current as a start capacitor, a PTCR resistance is available for approximately equal ohms. Table 3 can be used for conversion.

Even though the start current may be the same, the start torques may differ depending on the motor design. The PTCR has a fixed time built in. The start capacitor will stay in the circuit until a relay switches it out. The longer time provided by the capacitor and relay may be needed on applications where equalization is not present or adequate reset time is not available.

STARTING CURRENT APPROXIMATION BASED ON

$$X_c = \frac{1}{2\pi fC}$$

Table 3

START CAPACITOR	PTCR VALUE
50 μF	50 Ω
75 μF	37.5 Ω
100 μF	25 Ω
125 μF	20 Ω
200 μF	12.5 Ω
250 μF	10 Ω



PTCR SELECTION

- Choosing the best PTCR for an application is a simple matter. See Table 4 and Table 2. Vishay Cera-Mite PTCRs are available in three case sizes (A, B, and C).
- Table 4 indicates the correct case size for the application. Table 2 shows how to choose the correct resistance value.

- Using a device too small or resistance too high will give inadequate starting performance. An oversize device will not harm the motor, but may not be optimum with regards to acceleration dynamics, or power dissipation.
- The PTCR is generally self protecting when applied within the voltage and current ratings.
- All 305C Series starters and accessories are RoHS compliant.

Table 4

PTCR MOTOR START SELECTION CHART									
VISHAY CERA-MITE PART NUMBER	CASE STYLE	RESISTANCE (Ω)		SWITCH TIME (T) SECONDS AT 230 V	CURRENT RATING AMPERES	MAX. VOLTAGE RATING VOLTS, RMS	AVG. POWER DISSIPATION WATTS	COMPRESSOR RANGE	
		R _{DYN} ± 20 %	R ₀ ± 30 %					BTU (000)	HP
305C20*	C	25	35	0.25	10	410	3.5	10 - 28	0.75 - 2.0
305C21	C	35	50	0.35	8	410	3.5	8 - 18	0.5 - 1.5
305C22*	C	50	75	0.50	6	410	3.5	5 - 12	0.25 - 1.0
305C19*	B	20	30	0.50	18	500	7	20 - 50	1.5 - 4.0
305C12*	B	25	40	0.60	15	500	7	18 - 42	1.5 - 3.5
305C2	B	50	85	1.00	12	500	7	10 - 25	1.0 - 2.5
305C9*	A	10	15	0.50	36	500	9	28 - 68	3.0 - 7.0
305C11	A	12.5	20	0.60	30	500	9	28 - 62	3.0 - 6.0
305C1*	A	25	42.5	1.00	24	500	9	14 - 36	1.5 - 3.5
Note 1		Note 2		Note 3	Note 4	Note 5	Note 6	Note 7	

* Preferred Values

UL File E97640

Note 1

Part number is stamped on the device for UL recognition. The customer part number will also include 1 or 3 character alpha-numeric suffix to designate mounting bracket, customer marking, wire jumper, or other accessory furnished. The suffix is not marked on the part. Certified outline drawing and complete part number will be furnished on request for specific applications.

(Example: 305C19K01.) Mounting brackets and other accessories are shipped in separate boxes to simplify installation in end use equipment.

Note 2

R_{DYN} is nominal resistance equal to E/I when 230 volts, 60 Hz is applied (See Fig T-7). This resistance determines current and starting torque at the moment of application of voltage to the motor and can be measured with an oscilloscope.

For receiving inspection or routine trouble shooting, the D.C. resistance (R₀) as measured with an ohmmeter is approximately 50 % greater. For example: 305C20 measured with an ohmmeter would be 35 ohms ± 30 % tolerance.

Note 3

Resistance values are duplicated in several case sizes (i.e.: 305C20, C12, and C1) to provide longer switch time (t) and higher current ratings (See Fig T-7). Larger parts may be needed for more difficult starting conditions (voltage or temperature) or may be used for accelerating fans against back pressure.

Note 4

Maximum current in the PTCR is determined by
$$\frac{\text{Max Line Voltage}}{\text{Min } R_{DYN}}$$

Motor auxiliary winding impedance is usually small compared to PTCR resistance, and does not materially affect PTCR current.

Current in PTCR is a percentage of the full motor inrush (locked rotor) current; usually 30 % to 50 % (See Fig T-5).

Note 5

In application, the maximum voltage is the voltage that appears across the run capacitor at rated speed, high line, light load. This is not the applied line voltage (See Fig T-6).

THESE DEVICES ARE INTENDED FOR APPLICATION ON 240 VOLT LINES OR SYSTEMS WITH MAXIMUM LINE VOLTAGE UP TO 264 VOLTS.

The 305C20, 21 and 22 are also used on 120 volt systems where the motor is designed to use same run capacitor and PTCR as equivalent 230 volt compressor.

Note 6

This is the power used to keep the PTCR switched off under full load running conditions at typical ambient temperature.

Note 7

BTU and horsepower ranges are for reference only. PTCR may be applied outside those ranges as long as maximum voltage and maximum current are not exceeded. Scroll and rotary compressors may require less starting assistance allowing use of smaller devices.

DIMENSIONS FOR PTCR MOTOR START DEVICES - in inches

• **PACKAGED MOTOR START PTCRs ARE OFFERED IN THREE DIFFERENT CASE SIZES TO ACCOMMODATE THE RANGE OF PSC COMPRESSOR MOTORS SERVED**

CASE STYLE C

Case Style C is a 2-terminal single pellet device with current carrying capacity up to 10 amperes. It is furnished with a round mounting bracket.

CASE C	MOUNTING BRACKET
305C20 - Black 305C21 - Black 305C22 - Black	36-520M - Round

Fig T-8

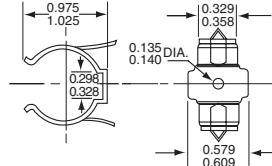
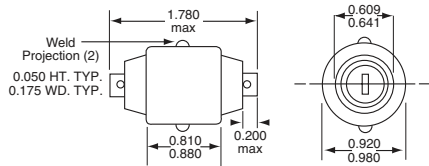

Round Bracket - Spring Steel Phosphate & Oil Finish. Accepts #6 Sheet Metal Screw

CASE STYLE B

Case Style B is a 2-terminal single pellet unit with current carrying capacity up to 18 amperes. Depending upon the model, either a U-shaped or round bracket is furnished.

CASE B	MOUNTING BRACKET
305C2 - Black 305C12 - Black or Blue 305C19 - Blue	7-36-5C - U-SHAPED 36-520H - ROUND

Fig T-9

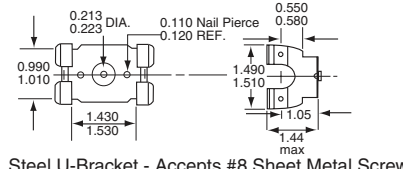
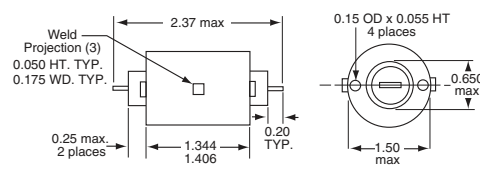

Steel U-Bracket - Accepts #8 Sheet Metal Screw

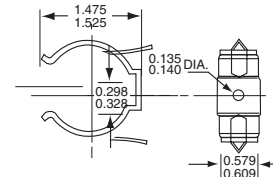

Round Bracket - Spring Steel Phosphate & Oil Finish. Accepts #6 Sheet Metal Screw

CASE STYLE A

Case Style A is a 3-terminal device that incorporates two pellets in parallel, resulting in lower resistance values and current carrying capacity up to 36 amperes. A jumper wire to complete the parallel connection with the two internal pellets is required.

CASE A	MOUNTING BRACKET	WIRE JUMPER
305C1 - Blue 305C9 - Tan 305C11 - Tan	7-36-4C - U-Shaped 36-520H - Round	50-1278 - 9.75" Long 105 °C Wire

Fig T-10

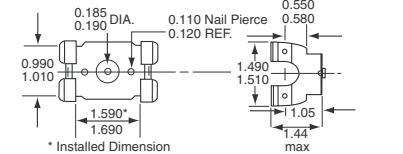
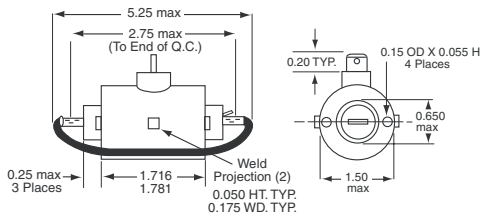

Steel U-Bracket - Accepts #8 Sheet Metal Screw

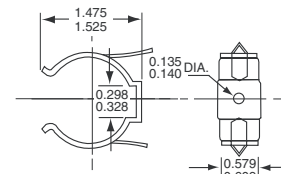

Round Bracket - Spring Steel Phosphate & Oil Finish. Accepts #6 Sheet Metal Screw

OPERATING TEMPERATURE

Under normal operation, the ceramic pellet inside the case reaches a temperature of 150 °C. The plastic case material has been recognized by UL for operation up to this temperature. The actual temperature on the outside of the case will be approximately 100 °C while the motor is running. An appropriate mounting location and 105 °C, 600 volt wiring are recommended.

CONNECTION DIAGRAMS

PTCR Motor Start units are connected directly across the PSC motor's "run" capacitor. Case style A is a 3-terminal device and uses an external jumper wire to connect the two internal pellets in parallel. A special "piggyback" terminal on the jumper wire provides for two connections on one side of the A-style case.

Fig T-11

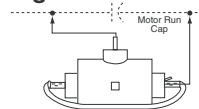

A Style
3-Terminal Case

Fig T-12

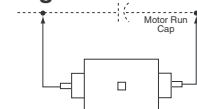

B & C Style
2-Terminal Case

VISHAY CERA-MITE MOTOR START FEATURES

ADVANCED CERAMIC ENGINEERING FOR HVAC

Vishay Cera-Mite's capability in large diameter ceramic pellets, unique formulations tailored to motor starting, and heavy duty electrode systems, have been developed and proven with the cooperation of HVAC industry experts over a period of 20 years.

INHERENT PERFORMANCE

Large diameter pellets make possible low resistance start devices needed to match torque requirements of high efficiency compressor motors.

Various package sizes offer selection of timing intervals, providing optimum switching time without dependence on sensing speed, counter EMF, or current.

RUGGED MECHANICAL CONSTRUCTION

Vishay Cera-Mite PTCR cases are molded from a UL94V0 high temperature, engineered plastic/glass composite.

Heavy duty aluminum contact plates and stainless steel force springs are scaled to the pellet sizes and current ratings to insure no internal arcing and to enhance quick reset time.

Unbreakable metal mounting brackets attach securely with a single screw. The NEW "U" - brackets developed by Vishay Cera-Mite feature lower power consumption and greater reliability by maximizing case to ground thermal impedance.

SIMPLE AND ECONOMICAL

A solid state device requiring only 2 quick connect wires and one bracket screw to install. Compared to the alternative start capacitor and relay, PTCR start devices save several wires, occupy less panel space, mount more easily, and cost less.

OUTSTANDING RELIABILITY

Over a fifteen year period, with an installed base of millions of Vishay Cera-Mite PTCR start devices, experience has demonstrated reliability at 1.0 FITS or less. Users have benefited from very low warranty expense.

RESTART CONSIDERATIONS

A properly sized PTCR will provide adequate starting current and starting time with a cool down time of 3 to 5 minutes, coordinating perfectly with standard "off delay" equalization timers Restart characteristics of the three case sizes are shown.

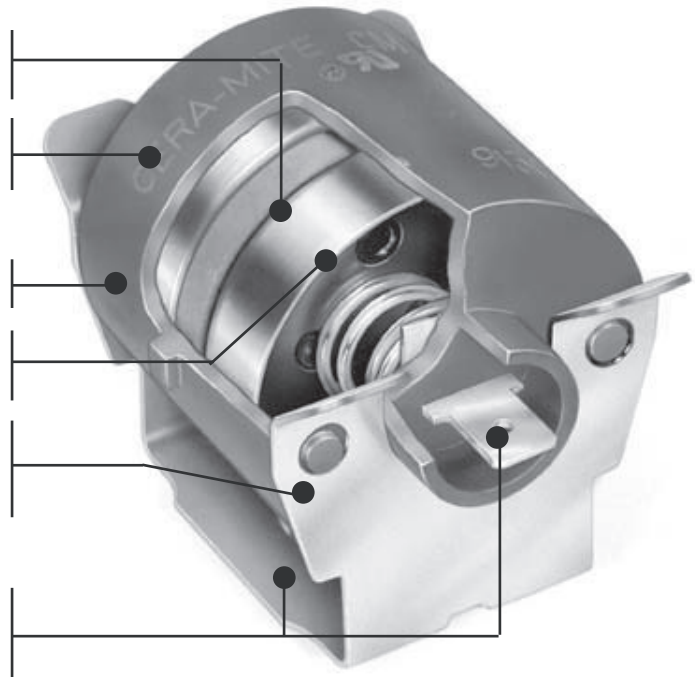

Fig T-13

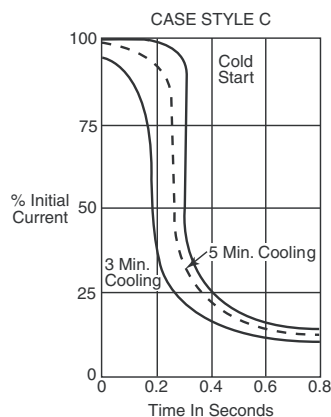

Fig T-14

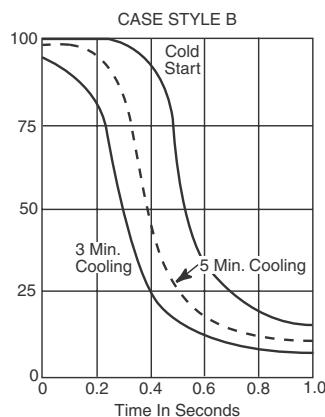
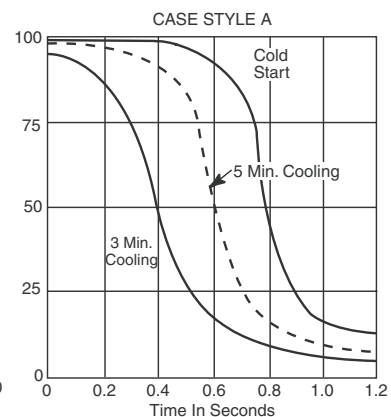

Fig T-15





Disclaimer

All product specifications and data are subject to change without notice.

Vishay Intertechnology, Inc., its affiliates, agents, and employees, and all persons acting on its or their behalf (collectively, "Vishay"), disclaim any and all liability for any errors, inaccuracies or incompleteness contained herein or in any other disclosure relating to any product.

Vishay disclaims any and all liability arising out of the use or application of any product described herein or of any information provided herein to the maximum extent permitted by law. The product specifications do not expand or otherwise modify Vishay's terms and conditions of purchase, including but not limited to the warranty expressed therein, which apply to these products.

No license, express or implied, by estoppel or otherwise, to any intellectual property rights is granted by this document or by any conduct of Vishay.

The products shown herein are not designed for use in medical, life-saving, or life-sustaining applications unless otherwise expressly indicated. Customers using or selling Vishay products not expressly indicated for use in such applications do so entirely at their own risk and agree to fully indemnify Vishay for any damages arising or resulting from such use or sale. Please contact authorized Vishay personnel to obtain written terms and conditions regarding products designed for such applications.

Product names and markings noted herein may be trademarks of their respective owners.