

## DP8483 TTL to 100k ECL Level Translator with Latch

### General Description

This circuit translates TTL input levels to ECL output levels and provides a fall-through latch. The outputs are gated with CS providing for wire ORing of outputs. The strobe and chip select inputs operate at ECL levels.

### Features

- 16-pin DIP or S.O.
- ECL control inputs
- CS provided for wire ORing of output bus
- 100k ECL I/O compatible
- 3.0 ns typical propagation delay

### Logic and Connection Diagram

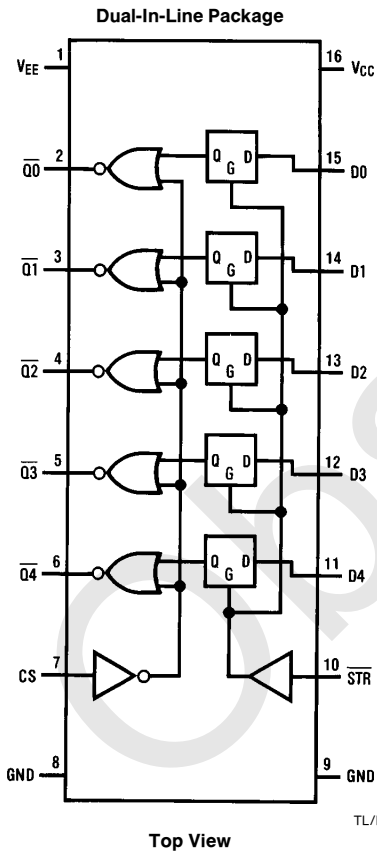

### Truth Table

D	$\bar{Q}$	$\overline{STR}$	CS
H	L	L	H
L	H	L	H
X	$\bar{Q}$	H	H
X	L	X	L

H = high level (most positive)  
 L = low level (most negative)  
 X = don't care

Order Number DP8483J,  
 DP8483M or DP8483N  
 See NS Package Number J16A, M16B or N16A

## Absolute Maximum Ratings (Note 1)

If Military/Aerospace specified devices are required, please contact the National Semiconductor Sales Office/Distributors for availability and specifications.

$V_{EE}$ Supply Voltage	-8V
$V_{CC}$ Supply Voltage	7V
Input Voltage (ECL)	GND to $V_{EE}$
Input Voltage (TTL)	-1V to 5.5V
Output Current	50 mA

Maximum Power Dissipation* at 25°C	1476 mW
Molded Package	
Storage Temperature	-65°C to +150°C
*Derate molded package 11.8 mW/°C above 25°C.	

## Recommended Operating Conditions

$V_{EE}$ Supply Voltage	-4.5V +7%
$V_{CC}$ Supply Voltage	5.0V ±10%
$T_A$ , Ambient Temperature	0°C to 85°C

## Electrical Characteristics (TTL Logic) (Notes 2 and 3)

Symbol	Parameter	Conditions	Min	Typ	Max	Units
$V_{IL}$	Input Low Voltage				0.8	V
$V_{IH}$	Input High Voltage		2.0			V
$I_{IL}$	Input Low Current	$V_{IN} = 0.5V$		-25	-200	$\mu A$
$I_{IH}$	Input High Current	$V_{IN} = 2.5V$		1.0	40	$\mu A$
$V_{CLAMP}$	Input Clamp Voltage	$I_{IN} = -12 mA$		-0.9	-1.2	V
$I_{CC}$	Supply Current	$V_{CC} = 5.5V$		10	20	mA

## Electrical Characteristics (ECL Logic) (Notes 2 and 3)

Symbol	Parameter	Conditions	Min	Typ	Max	Units
$V_{IL}$	Input Low Voltage	$V_{EE} = -4.5V$	-1810		-1475	mV
$V_{IH}$	Input High Voltage	$V_{EE} = -4.5V$	-1165		-880	mV
$I_{IL}$	Input Low Current	$V_{IN} = -1.8V$		45	150	$\mu A$
$I_{IH}$	Input High Current	$V_{IN} = -0.8V$		75	200	$\mu A$
$V_{OL}$	Output Low Voltage	$V_{EE} = -4.5V$	-1810	-1705	-1620	mV
$V_{OH}$	Output High Voltage	$V_{EE} = -4.5V$	-1025	-955	-880	mV
$V_{OLC}$	Output Low Voltage	$V_{EE} = -4.5V$			-1610	mV
$V_{OHC}$	Output High Voltage	$V_{EE} = -4.5V$	-1035			mV
$I_{EE}$	Supply Current	$V_{EE} = -4.8V$		-65	-85	mA

## Switching Characteristics (Notes 2 and 4)

Symbol	Parameter	Conditions	Min	Typ	Max	Units
$t_{PD1}$	Strobe To Output Delay	(Note 4)	1.5	3.0	6.0	ns
$t_{PD2}$	Data To Output Delay		2.5	4.5	7.5	ns
$t_S$	Data Set-Up Time to Strobe		5.0	2.0		ns
$t_H$	Data Hold Time		1.0	0		ns
$t_{PW}$	Strobe Pulse Width		5.0	3.0		ns
$t_{PD3}$	Chip Select to Output Delay		1.0	2.5	4.0	ns
$t_{SCS}$	Data Set-Up Time to Chip Select		5.5	3.0		ns

**Note 1:** "Absolute Maximum Ratings" are those values beyond which the safety of the device cannot be guaranteed. They are not meant to imply that the device should be operated at these limits. The table of "Electrical Characteristics" provides conditions for actual device operation.

**Note 2:** Unless otherwise specified, min/max limits apply across the 0°C to 85°C ambient temperature range in still air and across the specified supply variations. All typical values are for 25°C and nominal supply.

**Note 3:** All currents into device pins are shown as positive; all currents out of device pins are shown as negative. All voltages are referenced to ground, unless otherwise specified.

**Note 4:** Unless otherwise specified, all AC measurements are referenced from the 1.5V level of the TTL input and to/from the 50% point of the ECL signal and a 50 $\Omega$  resistor to -2V is the load. ECL input rise and fall times are 0.7 ns ± 0.1 ns from 20% to 80%. TTL input characteristics is 0V to 3V with  $t_r = t_f \leq 3$  ns measured from 10% to 90%.

## Switching Time Waveforms

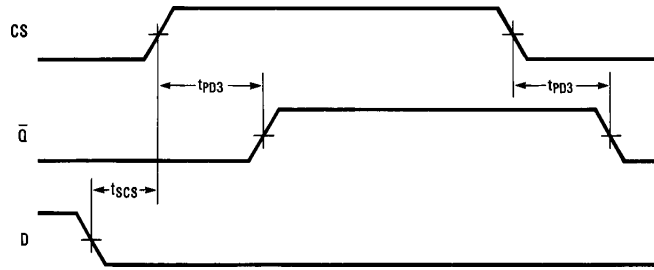

TL/F/5864-2

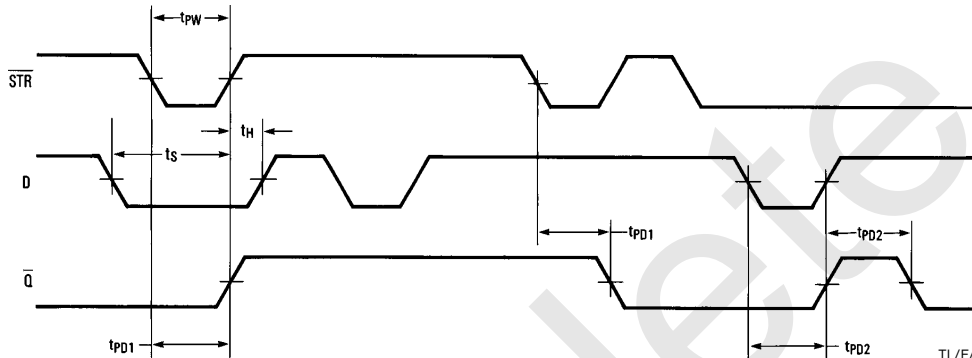

TL/F/5864-3

## Physical Dimensions inches (millimeters)

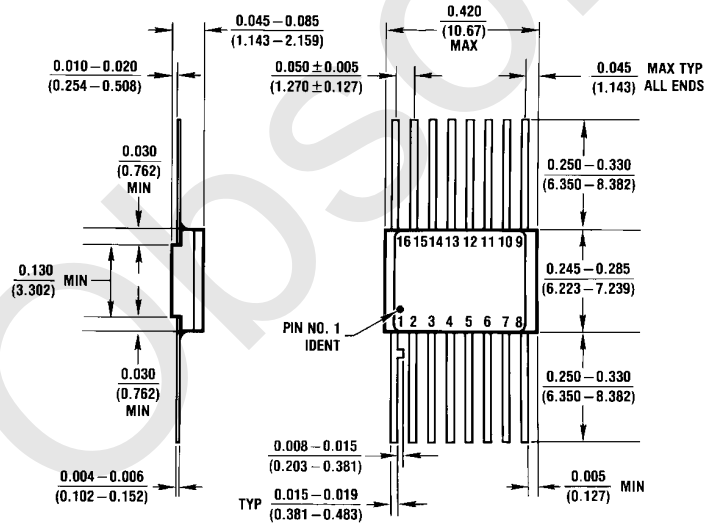

Ceramic Flat Package (F)  
Order Number DP8483F  
NS Package Number F16B

F16B (REV K)

Obsolete



**Physical Dimensions** inches (millimeters) (Continued)

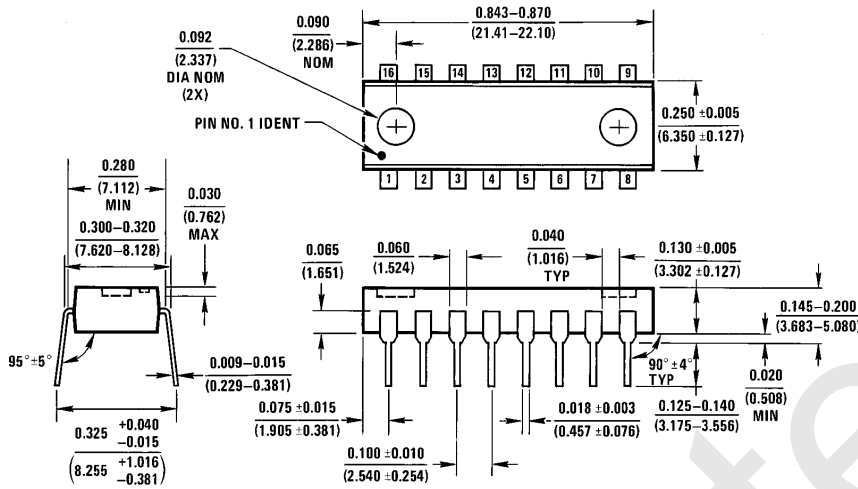

**Molded Dual-In-Line Package (N)**  
**Order Number DP8483N**  
**NS Package Number N16A**

N16A (REV E)

**LIFE SUPPORT POLICY**

NATIONAL'S PRODUCTS ARE NOT AUTHORIZED FOR USE AS CRITICAL COMPONENTS IN LIFE SUPPORT DEVICES OR SYSTEMS WITHOUT THE EXPRESS WRITTEN APPROVAL OF THE PRESIDENT OF NATIONAL SEMICONDUCTOR CORPORATION. As used herein:

1. Life support devices or systems are devices or systems which, (a) are intended for surgical implant into the body, or (b) support or sustain life, and whose failure to perform, when properly used in accordance with instructions for use provided in the labeling, can be reasonably expected to result in a significant injury to the user.
2. A critical component is any component of a life support device or system whose failure to perform can be reasonably expected to cause the failure of the life support device or system, or to affect its safety or effectiveness.



**National Semiconductor Corporation**  
 1111 West Bardin Road  
 Arlington, TX 76017  
 Tel: 1(800) 272-9959  
 Fax: 1(800) 737-7018

**National Semiconductor Europe**  
 Fax: (+49) 0-180-530 85 86  
 Email: onjwge@tevm2.nsc.com  
 Deutsch Tel: (+49) 0-180-530 85 85  
 English Tel: (+49) 0-180-532 78 32  
 Français Tel: (+49) 0-180-532 93 58  
 Italiano Tel: (+49) 0-180-534 16 80

**National Semiconductor Hong Kong Ltd.**  
 19th Floor, Straight Block,  
 Ocean Centre, 5 Canton Rd.  
 Tsimshatsui, Kowloon  
 Hong Kong  
 Tel: (852) 2737-1600  
 Fax: (852) 2736-9960

**National Semiconductor Japan Ltd.**  
 Tel: 81-043-299-2309  
 Fax: 81-043-299-2408

National does not assume any responsibility for use of any circuitry described, no circuit patent licenses are implied and National reserves the right at any time without notice to change said circuitry and specifications.