

# NEC

## HIGH ISOLATION VOLTAGE LARGE FORWARD AC INPUT TYPE MULTI OPTOCOUPLER SERIES

PS2521-1, -2, -4  
PS2521L-1, -2, -4

### FEATURES

- **HIGH ISOLATION VOLTAGE**  
BV: 5 k Vr.m.s. MIN
- **LARGE FORWARD INPUT CURRENT**  
IF = 150 mA MAX
- **HIGH SPEED SWITCHING**  
tr = 3 μs, tf = 5 μs TYP
- **HIGH COLLECTOR TO EMITTER VOLTAGE**  
VCEO: 80 V MIN
- **GULL-WING & LEAD BENDING OPTIONS**  
PS2521L1, PS2521L2
- **TAPING PRODUCTS**  
PS2521L-1-E3, E4, PS2521L-2-E3, E4

### DESCRIPTION

PS2521-1,-2 and -4 and PS2521L-1, -2 and -4 are optically coupled isolators containing a GaAs light emitting diode and an NPN silicon phototransistor. PS2521-1,-2 and -4 are in a plastic DIP (Dual In-Line Package) and PS2521L-1, -2 and -4 are lead bending type (Gull-Wing) for surface mount.

### APPLICATIONS

- AC Line / Digital Logic
- Twisted Pair Line Receiver
- Telephone / Telegraph Line Receiver
- Sequence Controllers

1

### ELECTRICAL CHARACTERISTICS (TA = 25°C)

PART NUMBER			PS2521-1, -2, -4, PS2521L-1, -2, -4		
SYMBOLS	PARAMETERS	UNITS	MIN	TYP	MAX
Diode	VF	Forward Voltage, IF = 100 mA	V	1.3	1.7
	IR	Reverse Current, VR = 5V	μA		5
	C	Junction Capacitance, V = 0, f = 1.0 MHz	pF	70	
Transistor	ICEO	Collector to Emitter Dark Current, Vce = 80 V, IF = 0	nA		100
	BVCEO	Collector to Emitter Breakdown Voltage, Ic = 1 mA, IB = 0	V	80	
	BVECO	Emitter to Collector Breakdown Voltage, IE = 100 μA, IB = 0	V	6	
Coupled	CTR	Current Transfer Ratio, IF = 100 mA, VCE = 3 V	%	20	80
	VCE (sat)	Collector Saturation Voltage, IF = 100 mA, Ic = 4 mA	V		0.3
	R1-2	Isolation Resistance, Vin-out = 1.0 kV	Ω	10 <sup>11</sup>	
	C1-2	Isolation Capacitance, V = 0, f = 1.0 MHz	pF	0.6	
	tr	Rise Time <sup>2</sup> , Vcc = 10 V, Ic = 2 mA	μs	3	
tf	Fall Time <sup>2</sup> , Vcc = 10 V, Ic = 2 mA	μs	5		

#### 2. Test Circuit for Switching Time

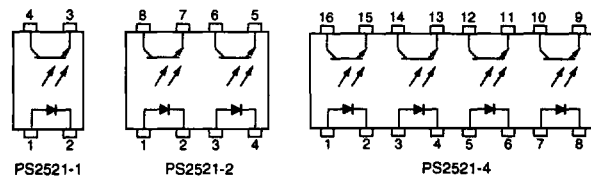
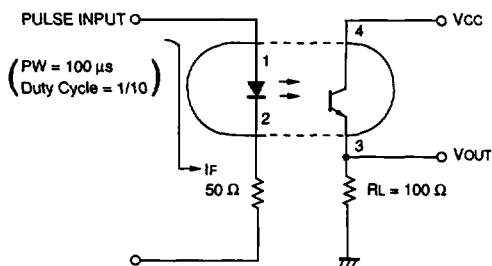

# PS2521-1, -2, -4, PS2521L-1, -2, -4

## ABSOLUTE MAXIMUM RATINGS<sup>1</sup> (T<sub>A</sub> = 25°C)

SYMBOLS	PARAMETERS	UNITS	RATINGS	
			PS2521-1 PS2521L-1	PS2521-2,4 PS2521L-2,4
<b>Diode</b>				
V <sub>R</sub>	Reverse Voltage	V	6	6
I <sub>F</sub>	Forward Current (DC)	mA	150	150
P <sub>D</sub>	Power Dissipation	mW	250	200
I <sub>F</sub> (PEAK)	Peak Forward Current (PW = 100 μs, Duty Cycle 1%)	A	1	1
<b>Transistor</b>				
V <sub>CEO</sub>	Collector to Emitter Voltage	V	80	80
V <sub>ECO</sub>	Emitter to Collector Voltage	V	6	6
I <sub>C</sub>	Collector Current	mA	50	50
P <sub>C</sub>	Power Dissipation	mW	150	120
<b>Coupled</b>				
BV	Isolation Voltage <sup>1</sup>	V <sub>r.m.s.</sub>	5000	5000
T <sub>STG</sub>	Storage Temperature	°C	-55 to +150	-55 to +150
T <sub>OP</sub>	Operating Temperature	°C	-55 to +100	-55 to +100

Note:

1. AC voltage for 1 minute at T<sub>A</sub> = 25 °C, RH = 60 % between input and output.

## TYPICAL PERFORMANCE CURVES (T<sub>A</sub> = 25°C)

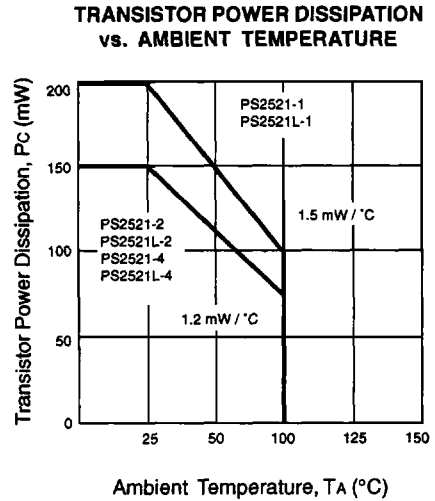
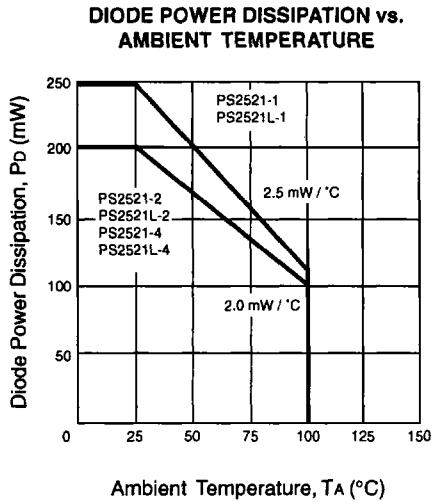

**TYPICAL PERFORMANCE CURVES** ( $T_A = 25^\circ\text{C}$ )

**FORWARD CURRENT vs. FORWARD VOLTAGE**

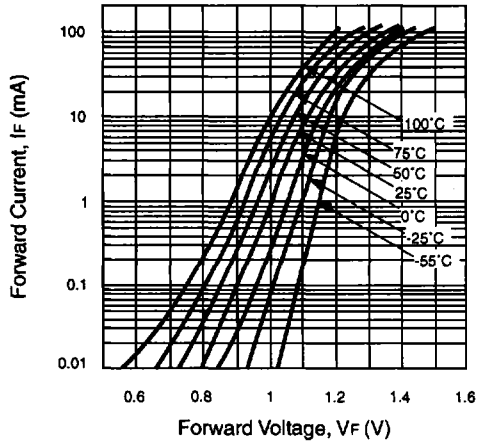

**COLLECTOR CURRENT vs. COLLECTOR TO EMITTER VOLTAGE**

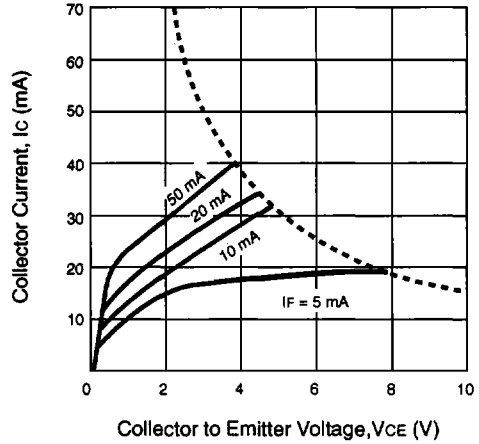

**COLLECTOR TO EMITTER DARK CURRENT vs. AMBIENT TEMPERATURE**

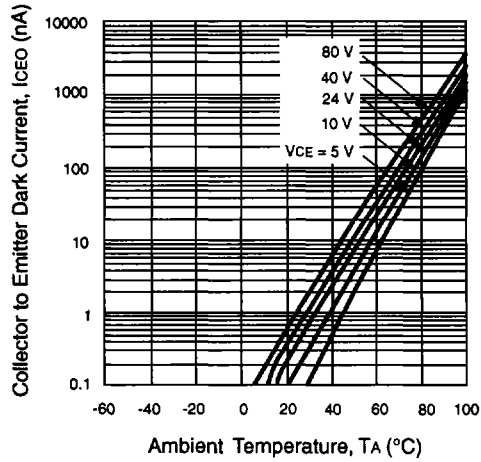

**COLLECTOR CURRENT vs. COLLECTOR SATURATION VOLTAGE**

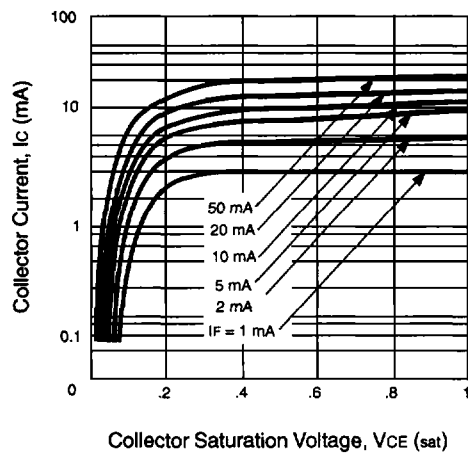

**NORMALIZED OUTPUT CURRENT vs. AMBIENT TEMPERATURE**

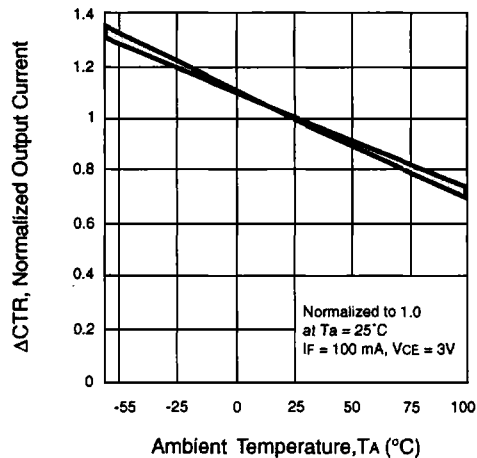

**CURRENT TRANSFER RATIO (CTR) vs. FORWARD CURRENT**

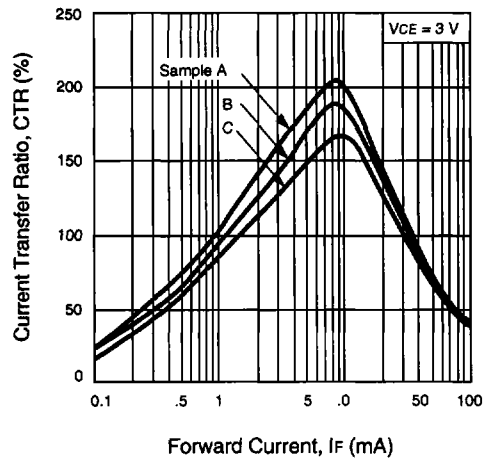

**TYPICAL PERFORMANCE CURVES** ( $T_A = 25^\circ\text{C}$ )

**SWITCHING TIME vs. LOAD RESISTANCE**

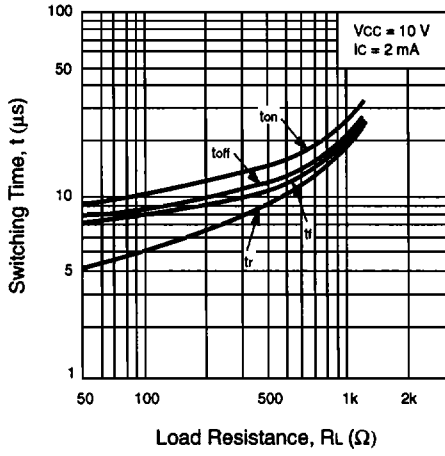

**FREQUENCY RESPONSE**

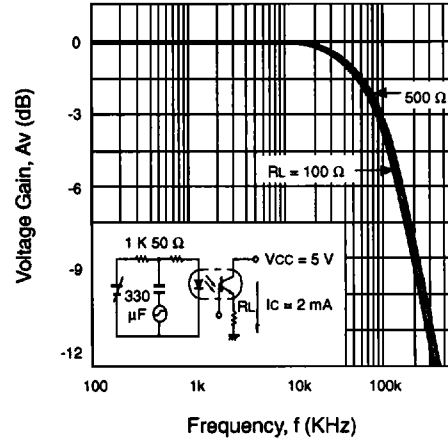

**CTR DEGRADATION**

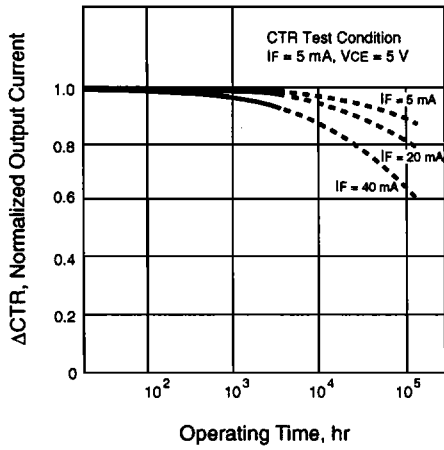

**PACKAGE DIMENSIONS** (Units in mm) DIP (Dual In-Line Package)

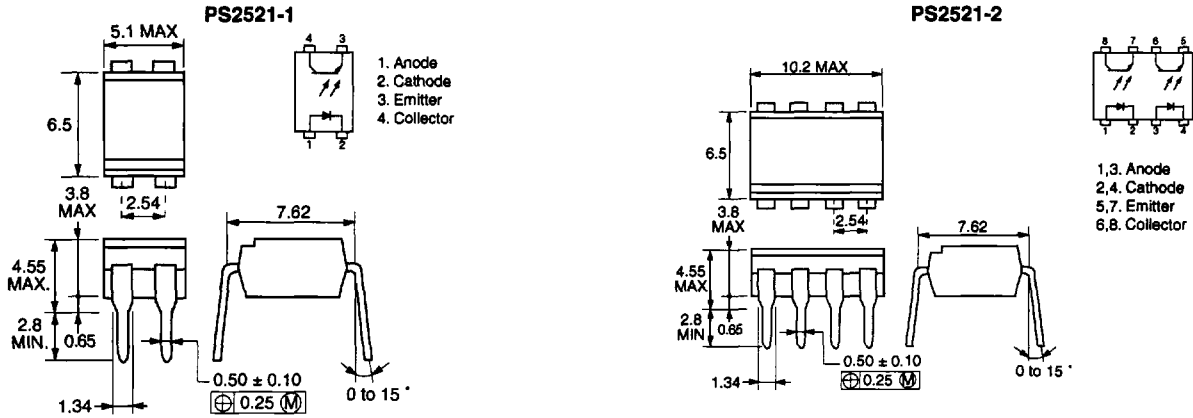

**PS2521-4**

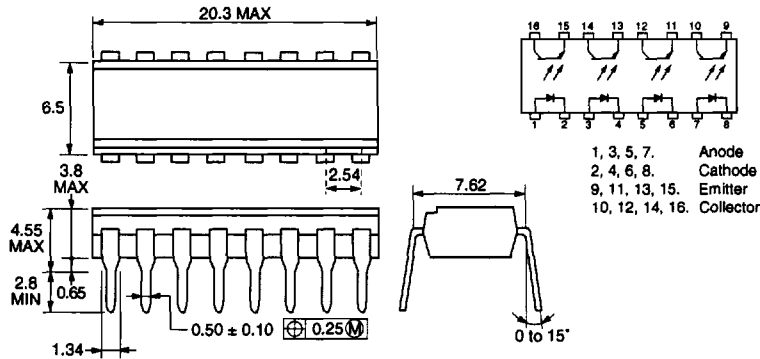

**PACKAGE DIMENSIONS** (Units in mm) Lead Bending type (Gull-wing)

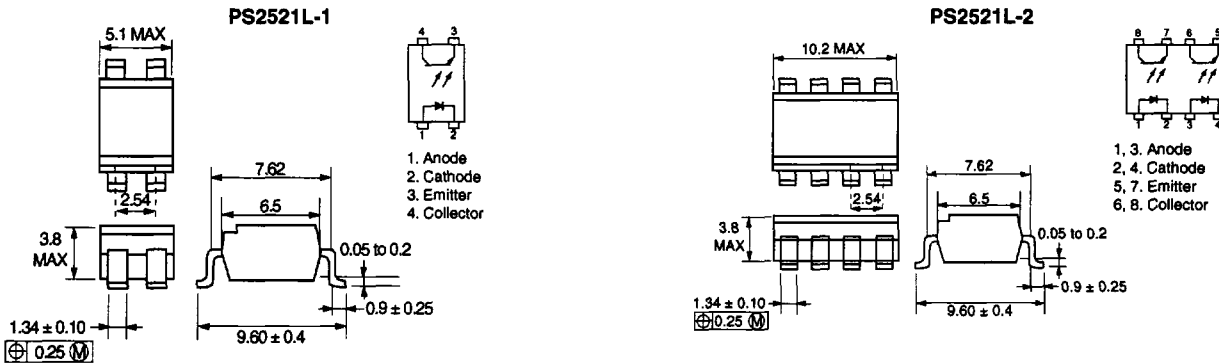

**PS2521L-4**

