

## EOLS-1603-XX Series

Single-Mode CWDM 155M SDH/SONET or 100M FE

Duplex SFP Transceiver

RoHS6 Compliant

### Features

- ◆ Operating Data Rate up to 155Mbps
- ◆ 18-Wavelength CWDM DFB LD Transmitter from 1270nm to 1610nm, with step 20nm
- ◆ Single 3.3V Power Supply and TTL Logic Interface
- ◆ Hot-Pluggable SFP Footprint Duplex LC Connector Interface
- ◆ Compliant with Class 1 FDA and IEC60825-1 Laser Safety
- ◆ Operating Case Temperature  
Standard: 0°C~+70°C  
Extended: -20°C~+85°C
- ◆ Compliant with SFP MSA
- ◆ Compliant with SFF-8472



### Applications

- ◆ SDH/SONET
- ◆ ATM Switches and Routers
- ◆ Fast Ethernet
- ◆ Other Optical Link

### Ordering Information

Part No.	Data Rate	Fibre	Power Budget	Interface	Temperature	DDMI
EOLS-1603-29X <sup>*(note1)</sup>	155/100Mbps	SMF	29dB	LC	Standard	NO
EOLS-1603-29XI	155/100Mbps	SMF	29dB	LC	Extended	NO
EOLS-1603-29XD	155/100Mbps	SMF	29dB	LC	Standard	YES
EOLS-1603-29XDI	155/100Mbps	SMF	29dB	LC	Extended	YES
EOLS-1603-34X <sup>*(note1)</sup>	155/100Mbps	SMF	34dB	LC	Standard	NO
EOLS-1603-34XI	155/100Mbps	SMF	34dB	LC	Extended	NO
EOLS-1603-34XD	155/100Mbps	SMF	34dB	LC	Standard	YES
EOLS-1603-34XDI	155/100Mbps	SMF	34dB	LC	Extended	YES

EOLS-1603-37X <sup>*(note1)</sup>	155/100Mbps	SMF	37dB	LC	Standard	NO
EOLS-1603-37XI	155/100Mbps	SMF	37dB	LC	Extended	NO
EOLS-1603-37XD	155/100Mbps	SMF	37dB	LC	Standard	YES
EOLS-1603-37XDI	155/100Mbps	SMF	37dB	LC	Extended	YES
EOLS-1603-47XD	155/100Mbps	SMF	47dB	LC	Standard	YES
EOLS-1603-47XDI	155/100Mbps	SMF	47dB	LC	Extended	YES

Note1: X refers to CWDM Wavelength range 1270nm to 1610nm, A=1270~R=1610nm.

\*The product image only for reference purpose.

### CWDM<sup>\*Note2</sup> Wavelength

Band	Nomenclature	Wavelength(nm)		
		Min.	Typ.	Max.
O-band Original	A	1264	1270	1277.5
	B	1284	1290	1297.5
	C	1304	1310	1317.5
	D	1324	1330	1337.5
	E	1344	1350	1357.5
E-band Extended	F	1364	1370	1377.5
	G	1384	1390	1397.5
	H	1404	1410	1417.5
	I	1424	1430	1437.5
	J	1444	1450	1457.5
S-band Short Wavelength	K	1464	1470	1477.5
	L	1484	1490	1497.5
	M	1504	1510	1517.5
	N	1524	1530	1537.5
C-band Conventional	O	1544	1550	1557.5
L-band Long Wavelength	P	1564	1570	1577.5
	Q	1584	1590	1597.5
	R	1604	1610	1617.5

Note2: 18 Wavelengths from 1270 nm to 1610 nm, with 20 nm span. Please contact EOPTOLINK to confirm the wavelength availability.

## Regulatory Compliance\*<sup>Note3</sup>

Product Certificate	Certificate Number	Applicable Standard
TUV	R50135086	EN 60950-1:2006+A11+A1+A12+A2
		EN 60825-1:2014
		EN 60825-2:2004+A1+A2
UL	E317337	UL 60950-1
		CSA C22.2 No. 60950-1-07
EMC CE	AE 50285865 0001	EN 55022:2010
		EN 55024:2010
FCC	WTF14F0514417E	47 CFR PART 15 OCT., 2013
FDA	/	CDRH 1040.10
ROHS	/	2011/65/EU

Note3: The above certificate number updated to June 2014, because some certificate will be updated every year, such as FDA and ROHS. For the latest certification information, please check with Eoptolink.

## Product Description

The EOLS-1603-XX series single mode transceiver is small form factor pluggable module for serial optical data communications such as SONET OC-3 / SDH STM-1 and Fast Ethernet. It is with the SFP 20-pin connector to allow hot plug capability. This module is designed for single mode fiber and operates at a nominal wavelength of CWDM. There are eighteen center wavelengths available from 1270nm to 1610nm, with each step 20nm.

The transmitter section uses a multiple quantum well CWDM DFB laser and is a class 1 laser compliant according to International Safety Standard IEC-60825. The receiver section uses an integrated InGaAs avalanche photodiode preamplifier (IDP) mounted in an optical header and a limiting post-amplifier IC.

The EOLS-1603-XX series are designed to be compliant with SFF-8472.

## Absolute Maximum Ratings

Parameter	Symbol	Min.	Max.	Unit
Storage Temperature	T <sub>s</sub>	-40	+85	°C
Supply Voltage	V <sub>cc</sub>	-0.5	3.6	V
Operating Relative Humidity		-	95	%

\*Exceeding any one of these values may destroy the device permanently.

## Recommended Operating Conditions

Parameter	Symbol	Min.	Typical	Max.	Unit	
Operating Case Temperature	T <sub>c</sub>	EOLS-1603-XX	0	-	+70	°C
		EOLS-1603-XXI	-20	-	+85	
Power Supply Voltage	V <sub>cc</sub>	3.15	3.3	3.45	V	
Power Supply Current	I <sub>cc</sub>	-	-	300	mA	
Date Rate	OC-3/STM-1	-	155	-	Mbps	

	100M		-	100	-	
--	------	--	---	-----	---	--

## Performance Specifications - Electrical

Parameter	Symbol	Min.	Typ.	Max	Unit	Notes
<b>Transmitter</b>						
LVPECL Inputs(Differential)	Vin	400		2000	mVpp	AC coupled inputs*(note4)
Input Impedance (Differential)	Zin	85	100	115	ohm	Rin > 100 kohm @ DC
TX_Dis	Disable	2		Vcc	V	
	Enable	0		0.8		
TX_FAULT	Fault	2		Vcc	V	
	Normal	0		0.8		
<b>Receiver</b>						
LVPECL Outputs (Differential)	Vout	370		2000	mVpp	AC coupled outputs*(note4)
Output Impedance (Differential)	Zout	85	100	115	ohm	
RX_LOS	LOS	2		Vcc	V	
	Normal	0		0.8	V	
MOD_DEF ( 0:2 )	VoH	2.5			V	
	VoL	0		0.8	V	

## Performance Specifications - Optical

(CWDM DFB and PIN/TIA, 29dB Power Budget at Least)

Parameter	Symbol	Min.	Typical	Max.	Unit
Data Rate			100/155		Mbps
<b>Transmitter</b>					
Center Wavelength	$\lambda_c$	$\lambda_c-6$	$\lambda_c$	$\lambda_c+7.5$	nm
Spectral Width (-20dB)	$\Delta\lambda$			1	nm
Side Mode Suppression Ratio	SMSR	30			dB
Average Output Power*(note5)	Pout	-5		0	dBm
Extinction Ratio*(note6)	ER	10			dB
Rise/Fall Time(20%~80%)	tr/tf			2	ns
Output Optical Eye*(note6)	IUT-T G.957 Compliant*(note9)				
TX_Disable Assert Time	t_off			10	us
<b>Receiver</b>					
Center Wavelength	$\lambda_c$	1100		1650	nm
Receiver Sensitivity*(note7)	Pmin			-34	dBm
Receiver Overload	Pmax	-8			dBm
Return Loss		14			dB
Optical Path Penalty*(note8)				1	dB

LOS De-Assert	LOSD			-35	dBm
LOS Assert	LOSA	-45			dBm
LOS Hysteresis*(note10)		0.5			dB

### (CWDM DFB and PIN/TIA, 34dB Power Budget at Least)

Parameter	Symbol	Min.	Typical	Max.	Unit
Data Rate			100/155		Mbps
<b>Transmitter</b>					
Center Wavelength	$\lambda_c$	$\lambda_c-6$	$\lambda_c$	$\lambda_c+7.5$	nm
Spectral Width (-20dB)	$\Delta\lambda$			1	nm
Side Mode Suppression Ratio	SMSR	30			dB
Average Output Power*(note5)	Pout	0		5	dBm
Extinction Ratio*(note6)	ER	10			dB
Rise/Fall Time(20%~80%)	tr/tf			2	ns
Output Optical Eye*(note6)	IUT-T G.957 Compliant*(note9)				
TX_Disable Assert Time	t_off			10	us
<b>Receiver</b>					
Center Wavelength	$\lambda_c$	1100		1650	nm
Receiver Sensitivity*(note7)	Pmin			-34	dBm
Receiver Overload	Pmax	-10			dBm
Return Loss		14			dB
Optical Path Penalty*(note8)				1	dB
LOS De-Assert	LOSD			-35	dBm
LOS Assert	LOSA	-45			dBm
LOS Hysteresis*(note10)		0.5			dB

### (CWDM DFB and PIN/TIA, 37dB Power Budget at Least)

Parameter	Symbol	Min.	Typical	Max.	Unit
Data Rate			100/155		Mbps
<b>Transmitter</b>					
Center Wavelength	$\lambda_c$	$\lambda_c-6$	$\lambda_c$	$\lambda_c+7.5$	nm
Spectral Width (-20dB)	$\Delta\lambda$			1	nm
Side Mode Suppression Ratio	SMSR	30			dB
Average Output Power*(note5)	Pout	2		7	dBm
Extinction Ratio*(note6)	ER	10			dB
Rise/Fall Time(20%~80%)	tr/tf			2	ns
Output Optical Eye*(note6)	IUT-T G.957 Compliant*(note9)				
TX_Disable Assert Time	t_off			10	us
<b>Receiver</b>					
Center Wavelength	$\lambda_c$	1100		1650	nm
Receiver Sensitivity*(note7)	Pmin			-35	dBm
Receiver Overload	Pmax	-10			dBm
Return Loss		14			dB

Optical Path Penalty*(note8)				1	dB
LOS De-Assert	LOSD			-36	dBm
LOS Assert	LOSA	-45			dBm
LOS Hysteresis*(note10)		0.5			dB

**(CWDM DFB and APD, 47dB Power Budget at Least)**

Parameter	Symbol	Min.	Typical	Max.	Unit
Data Rate			100/155		Mbps
<b>Transmitter</b>					
Center Wavelength	$\lambda_c$	$\lambda_c-6$	$\lambda_c$	$\lambda_c+7.5$	nm
Spectral Width (-20dB)	$\Delta\lambda$			1	nm
Side Mode Suppression Ratio	SMSR	30			dB
Average Output Power*(note5)	Pout	3		7	dBm
Extinction Ratio*(note6)	ER	10			dB
Rise/Fall Time(20%~80%)	tr/tf			2	ns
Output Optical Eye*(note6)	IUT-T G.957 Compliant*(note9)				
TX_Disable Assert Time	t_off			10	us
<b>Receiver</b>					
Center Wavelength	$\lambda_c$	1100		1650	nm
Receiver Sensitivity*(note7)	Pmin			-44	dBm
Receiver Overload	Pmax	-10			dBm
Return Loss		14			dB
Optical Path Penalty*(note8)				1	dB
LOS De-Assert	LOSD			-45	dBm
LOS Assert	LOSA	-55			dBm
LOS Hysteresis*(note10)		0.5			dB

Note4: LVPECL logic, internally AC coupled.

Note5: Output is coupled into a 9/125 $\mu$ m single-mode fiber.

Note6: Filtered, measured with a PRBS 2<sup>23</sup>-1 test pattern @155Mbps

Note7: Minimum average optical power measured at BER less than 1E-10, with a 2<sup>23</sup>-1 PRBS and ER=10dB.

Note8: Measured with a PRBS 2<sup>23</sup>-1 test pattern @155Mbps, BER  $\leq 1 \times 10^{-10}$ .

Note9: Eye Pattern Mask

Note10: LOS Hysteresis

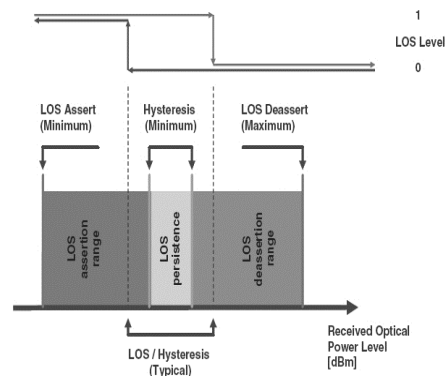
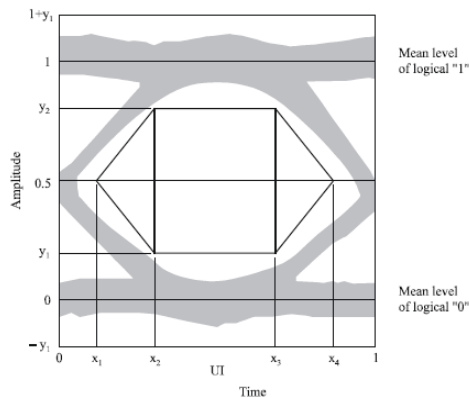

## Functional Description of Transceiver

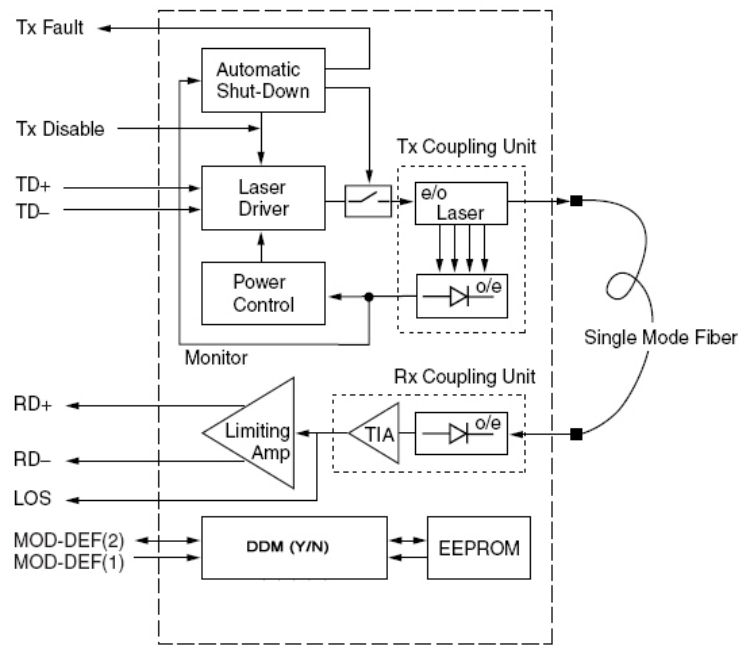

## SFP Transceiver Electrical Pad Layout

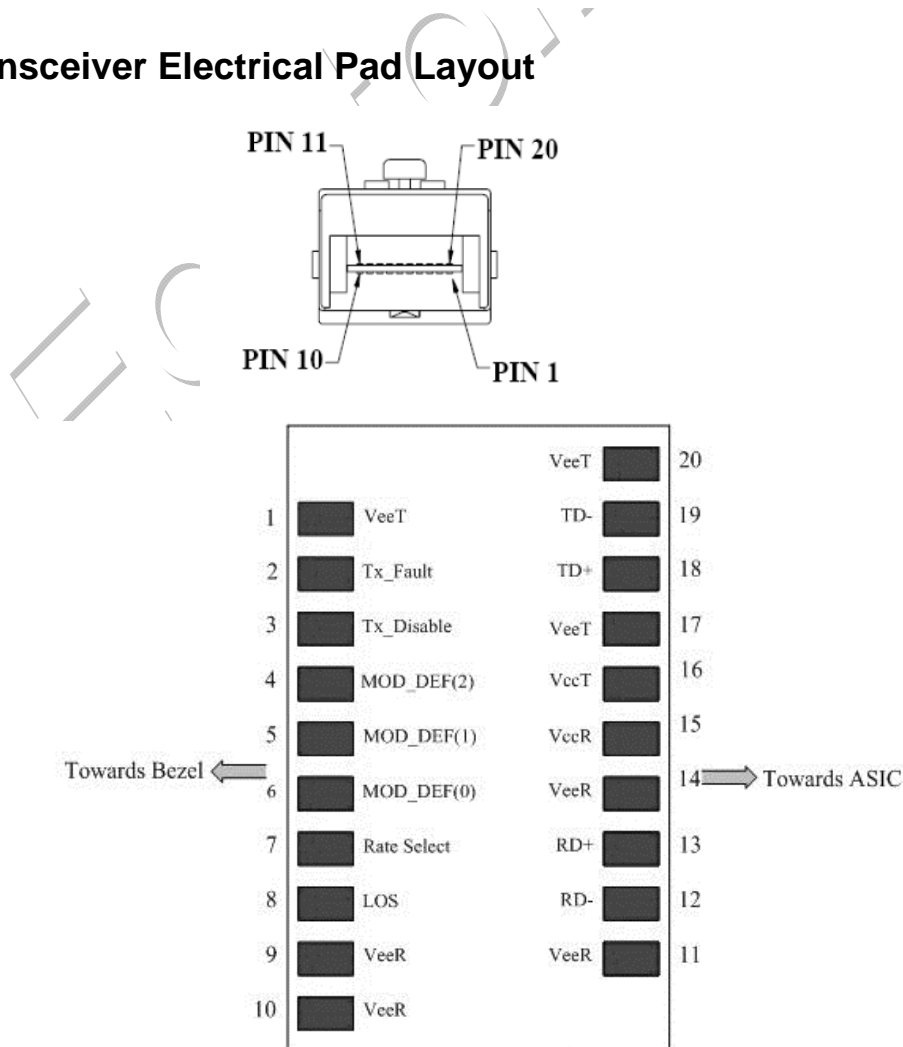

## Pin Function Definitions

Pin Num.	Name	Function Description
1	VeeT	Transmitter Ground
2	TX Fault	Transmitter Fault Indication, open collector/drain output
3	TX Disable	Transmitter Disable
4	MOD-DEF2	Module Definition 2, Data line for Serial ID.
5	MOD-DEF1	Module Definition 1, Clock line for Serial ID.
6	MOD-DEF0	Module Definition 0, Grounded within the module.
7	Rate Select	Not Connect, Function not available
8	LOS	Loss of Signal, open collector/drain output
9	VeeR	Receiver Ground
10	VeeR	Receiver Ground
11	VeeR	Receiver Ground
12	RD-	Inv. Received Data Out
13	RD+	Received Data Out
14	VeeR	Receiver Ground
15	VccR	Receiver Power, 3.3 ± 5%
16	VccT	Transmitter Power, 3.3 ± 5%
17	VeeT	Transmitter Ground
18	TD+	Transmit Data In
19	TD-	Inv. Transmit Data In
20	VeeT	Transmitter Ground

### EEPROM

The serial interface uses the 2-wire serial CMOS EEPROM protocol defined for the ATMEL AT24C02/04 family of components. When the serial protocol is activated, the host generates the serial clock signal (SCL). The positive edge clocks data into those segments of the EEPROM that are not write protected within the SFP transceiver. The negative edge clocks data from the SFP transceiver. The serial data signal (SDA) is bi-directional for serial data transfer. The host uses SDA in conjunction with SCL to mark the start and end of serial protocol activation. The memories are organized as a series of 8-bit data words that can be addressed individually or sequentially.

The Module provides diagnostic information about the present operating conditions. The transceiver generates this diagnostic data by digitization of internal analog signals. Calibration and alarm/warning threshold data is written during device manufacture. Received power monitoring, transmitted power monitoring, bias current monitoring, supply voltage monitoring and temperature monitoring all are implemented. If the module is defined as external calibrated, the diagnostic data are raw A/D values and must be converted to real world units using calibration constants stored in EEPROM locations 56 – 95 at wire serial bus address A2H. The digital diagnostic memory map specific data field define as following .For detail EEPROM information, please refer to the related document of SFF 8472 Rev 9.3.

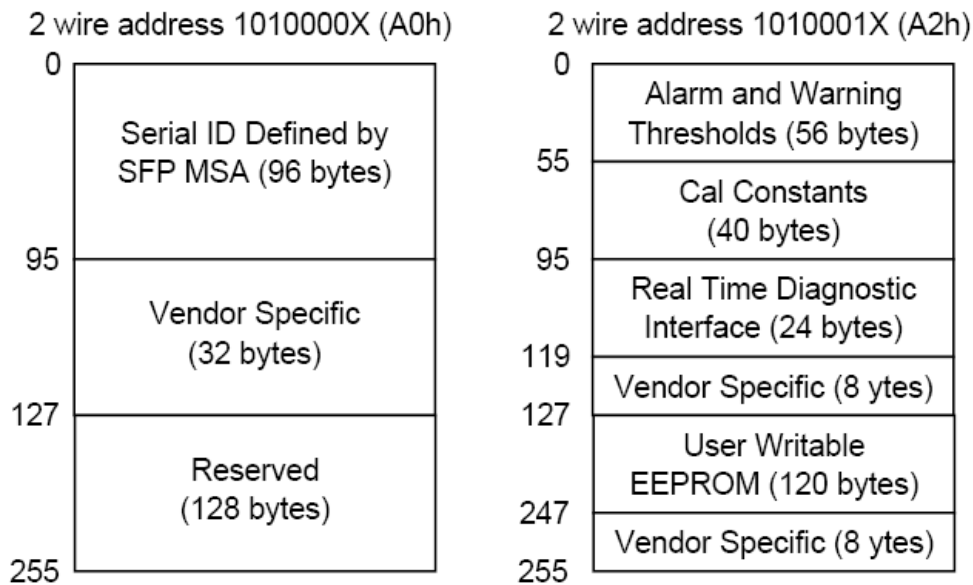

## EEPROM Serial ID Memory Contents

Accessing Serial ID Memory uses the 2 wire address 1010000X (A0H). Memory Contents of Serial ID are shown in Table 1.

**Table 1 Serial ID Memory Contents**

Addr.	Size (Bytes)	Name of Field	Hex	Description
<b>BASE ID FIELDS</b>				
0	1	Identifier	03	SFP
1	1	Ext. Identifier	04	SFP function is defined by serial ID only
2	1	Connector	07	LC Connector
3-10	8	Transceiver	XX XX XX XX XX XX XX XX <sup>(note11)</sup>	OC 3, Single mode, long reach
11	1	Encoding	03	NRZ
12	1	BR, Nominal	01	155Mbps
13	1	Reserved	00	
14	1	Length (9µm)km	XX	Transceiver transmit distance
15	1	Length(9µm)100m	FF	
16	1	Length (50µm) 10m	00	
17	1	Length(62.5µm)10m	00	
18	1	Length (Copper)	00	Not compliant
19	1	Reserved	00	
20-35	16	Vendor name	XX XX XX XX XX XX XX XX XX XX XX XX XX XX XX XX <sup>(note11)</sup>	Vendor name
36	1	Reserved	00	

37-39	3	Vendor OUI	XX XX XX <sup>(note11)</sup>	
40-55	16	Vendor PN	XX XX XX XX XX XX XX XX XX XX XX XX XX XX XX XX <sup>(note11)</sup>	PN
56-59	4	Vendor rev	XX XX XX XX <sup>(note11)</sup>	
60-61	2	Wavelength	XX XX <sup>(note11)</sup>	Wavelength
62	1	Reserved	00	
63	1	CC_BASE	Check Sum (Variable)	Check code for Base ID Fields
<b>EXTENDED ID FIELDS</b>				
64-65	2	Options	00 1A	TX_DISABLE, TX_FAULT and Loss of Signal implemented.
66	1	BR, max	00	
67	1	BR, min	00	
68-83	16	Vendor SN	XX XX XX XX XX XX XX XX 20 20 20 20 20 20 20 20 <sup>(note11)</sup>	Serial Number of transceiver (ASCII). For example "B000822".
84-91	8	Date code	XX XX XX XX XX XX XX XX <sup>(note11)</sup>	Manufactory date code. For example "080405".
92	1	Diagnostic Monitoring Type	XX <sup>(note11)</sup>	Digital diagnostic monitoring implemented
93	1	Enhanced Options	XX <sup>(note11)</sup>	Optional flags
94	1	SFF_8472 Compliance	01	01 for diagnostics (Rev9.3 SFF-8472).
95	1	CC_EXT	Check Sum (Variable)	Check sum for Extended ID Field.
<b>VENDOR SPECIFIC ID FIELDS</b>				
96-127	32	Vendor Specific	Read only	Depends on customer information
128-255	128	Reserved	Read only	

Note11: The "XX" byte should be filled in according to practical case. For more information, please refer to the related document of SFP Multi-Source Agreement (MSA).

## Recommend Circuit Schematic

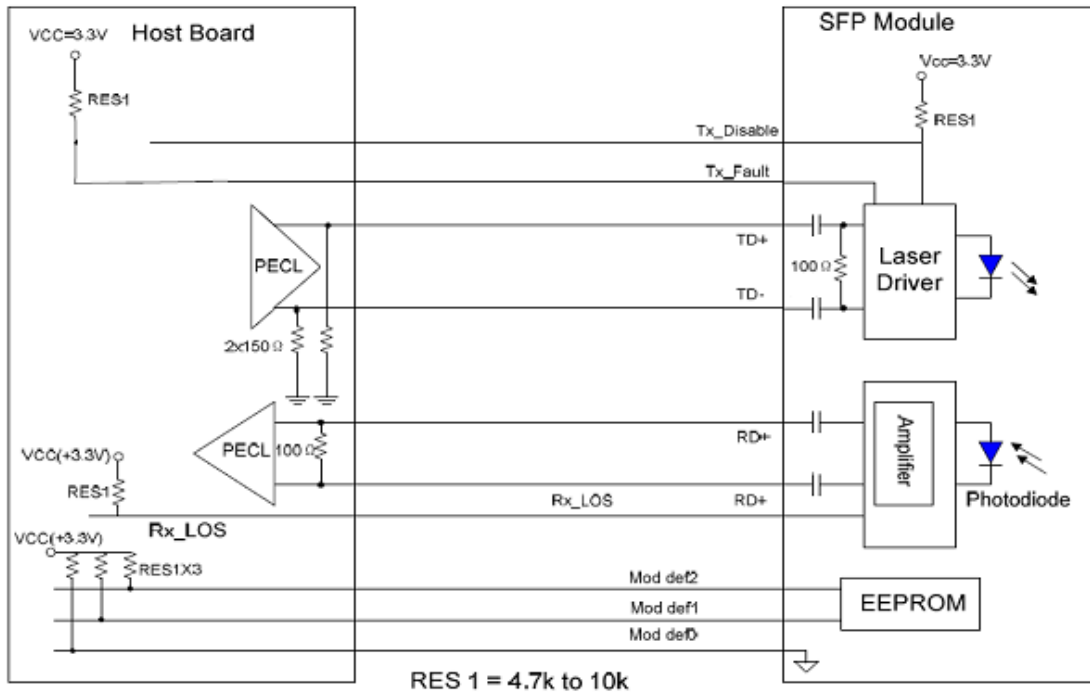

## Mechanical Specifications

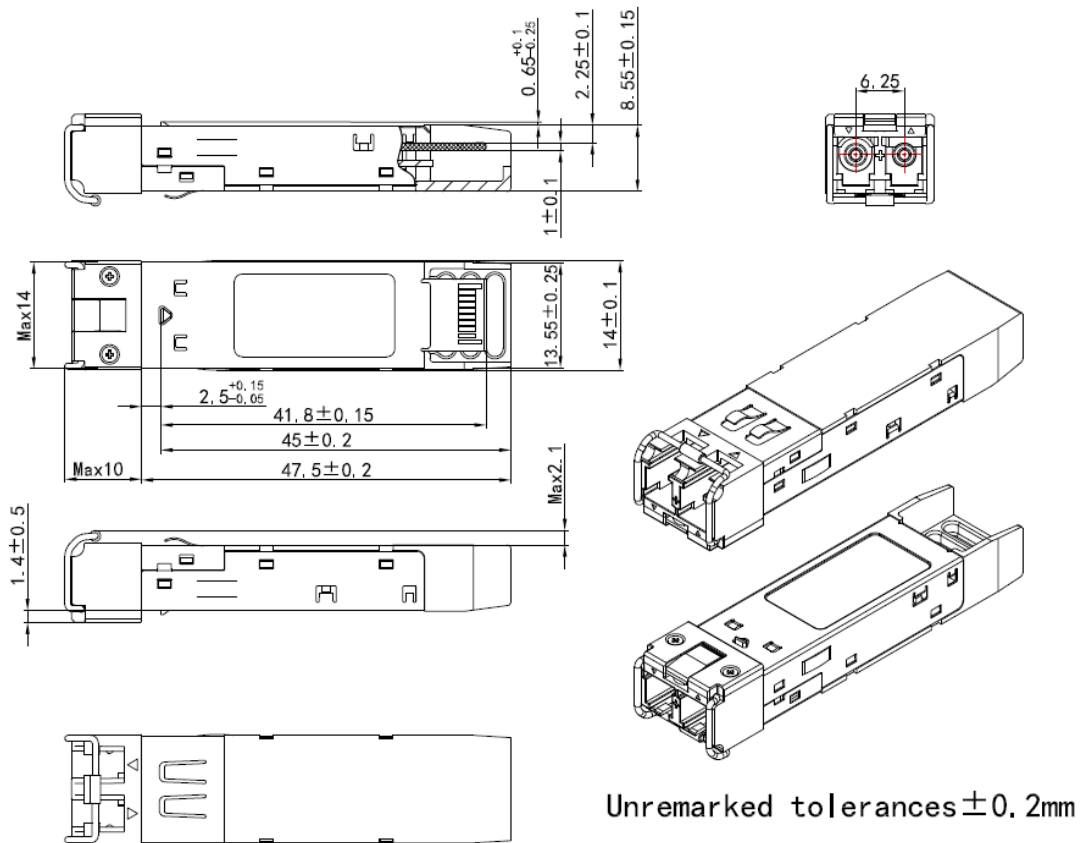

This 2D drawing only for reference, please check with Eoptolink before ordering.

## Obtaining Document

You can visit our website: <http://www.eoptolink.com>

Or contact Eoptolink Technology Inc., Ltd. Listed at the end of the documentation to get the latest documents.

## Revision History

Revision	Initiated	Reviewed	Approved	Revision History	Release Date
V2.a	Tim.Liang	Kelly.Cao		Released.	Oct 24, 2009
V2.b	Kelly			Revise the A2H.	Nov 24, 2009
V2.c	Kelly			Complete the CWDM wavelength.	Jan 18, 2010
V2.d	Kelly			Correct Rx $\lambda$ range.	Apr 8, 2010
V3.a	Kelly			Update PN&LOGO.	July 18, 2011
V3.b	Jans	Kelly		Integrate 4 products.	Sep 21, 2011
V3.c	Jans			Update temp. range .	June 18,2012
V3.d	Angela/Vina	Lyn/Jason/ Nygai		Update the regulatory compliance and 2D drawing. Change the min TX Power and Receiver sensitivity of 47Db product.	Sep 16 2015
V3.e	Angela	Kelly/Vina/ Dean		Update the regulatory compliance and 2D drawing.	May 24,2016
V3.f	Angela	Kelly/Daquan.Dong		Update the note7 and 2D drawing.	July 28, 2017
V3.g	Angela	Kelly/William/ Chao.Wang		Updated the product image and 2D drawing.	April 23, 2018

### Notice:

Eoptolink reserves the right to make changes to or discontinue any optical link product or service identified in this publication, without notice, in order to improve design and/or performance. Applications that are described herein for any of the optical link products are for illustrative purposes only. Eoptolink makes no representation or warranty that such applications will be suitable for the specified use without further testing or modification.

**Contact:**

Add: No.127 West Wulian Street, Gongxing Town, Shuangliu district, Chengdu City, Sichuan,  
China.

Tel: (+86) 028-67087999

Fax: (+86) 28-67087979-8010

Postal: 610213

E-mail: [sales@eoptolink.com](mailto:sales@eoptolink.com)

<http://www.eoptolink.com>

EOPTOLINK