

1428 MHz Dual Output LVPECL Clock Synthesizer

The MPC92433 is a 3.3 V compatible, PLL based clock synthesizer targeted for high performance clock generation in mid-range to high-performance telecom, networking, and computing applications. With output frequencies from 42.50 MHz to 1428 MHz and the support of two differential PECL output signals, the device meets the needs of the most demanding clock applications.

Features

- 42.50 MHz to 1428 MHz synthesized clock output signal
- Two differential, LVPECL-compatible high-frequency outputs
- Output frequency programmable through 2-wire I²C bus or parallel interface
- On-chip crystal oscillator for reference frequency generation
- Alternative LVCMOS compatible reference clock input
- Synchronous clock stop functionality for both outputs
- LOCK indicator output (LVCMOS)
- LVCMOS compatible control inputs
- Fully integrated PLL
- 3.3 V power supply
- 48-lead LQFP
- 48-lead Pb-free package available
- SiGe Technology
- Ambient temperature range: -40°C to +85°C

Typical Applications

- Programmable clock source for server, computing, and telecommunication systems
- Frequency margining
- Oscillator replacement

The MPC92433 is a programmable high-frequency clock source (clock synthesizer). The internal PLL generates a high-frequency output signal based on a low-frequency reference signal. The frequency of the output signal is programmable and can be changed on the fly for frequency margining purposes.

The internal crystal oscillator uses the external quartz crystal as the basis of its frequency reference. Alternatively, a LVCMOS compatible clock signal can be used as a PLL reference signal. The frequency of the internal crystal oscillator is divided by a selectable divider and then multiplied by the PLL. The VCO within the PLL operates over a range of 1360 to 2856 MHz. Its output is scaled by a divider that is configured by either the I²C or parallel interfaces. The crystal oscillator frequency f_{TAL}, the PLL pre-divider P, the feedback-divider M, and the PLL post-divider N determine the output frequency. The feedback path of the PLL is internal.

The PLL post-divider N is configured through either the I²C or the parallel interfaces, and can provide one of seven division ratios (2, 4, 6, 8, 12, 16, 32). This divider extends the performance of the part while providing a 50 Ω duty cycle. The high-frequency outputs, Q_A and Q_B, are differential and are capable of driving a pair of transmission lines terminated 50 Ω to V_{CC} - 2.0 V. The second high-frequency output, Q_B, can be configured to run at either 1x or 1/2x of the clock frequency or the first output (Q_A). The positive supply voltage for the internal PLL is separated from the power supply for the core logic and output drivers to minimize noise induced jitter.

The configuration logic has two sections: I²C and parallel. The parallel interface uses the values at the M[9:0], NA[2:0], NB, and P parallel inputs to configure the internal PLL dividers. The parallel programming interface has priority over the serial I²C interface. The serial interface is I²C compatible and provides read and write access to the internal PLL configuration registers. The lock state of the PLL is indicated by the LVCMOS-compatible LOCK output.

MPC92433

**1428 MHz LOW VOLTAGE
CLOCK SYNTHESIZER**



FA SUFFIX⁽¹⁾
48-LEAD LQFP PACKAGE
CASE 932-03

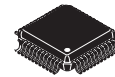

AE SUFFIX⁽²⁾
48-LEAD LQFP PACKAGE
Pb-FREE PACKAGE
CASE 932-03

1. FA suffix: leaded terminations.
2. AE suffix: lead-free, EPP and RoHS-compliant.

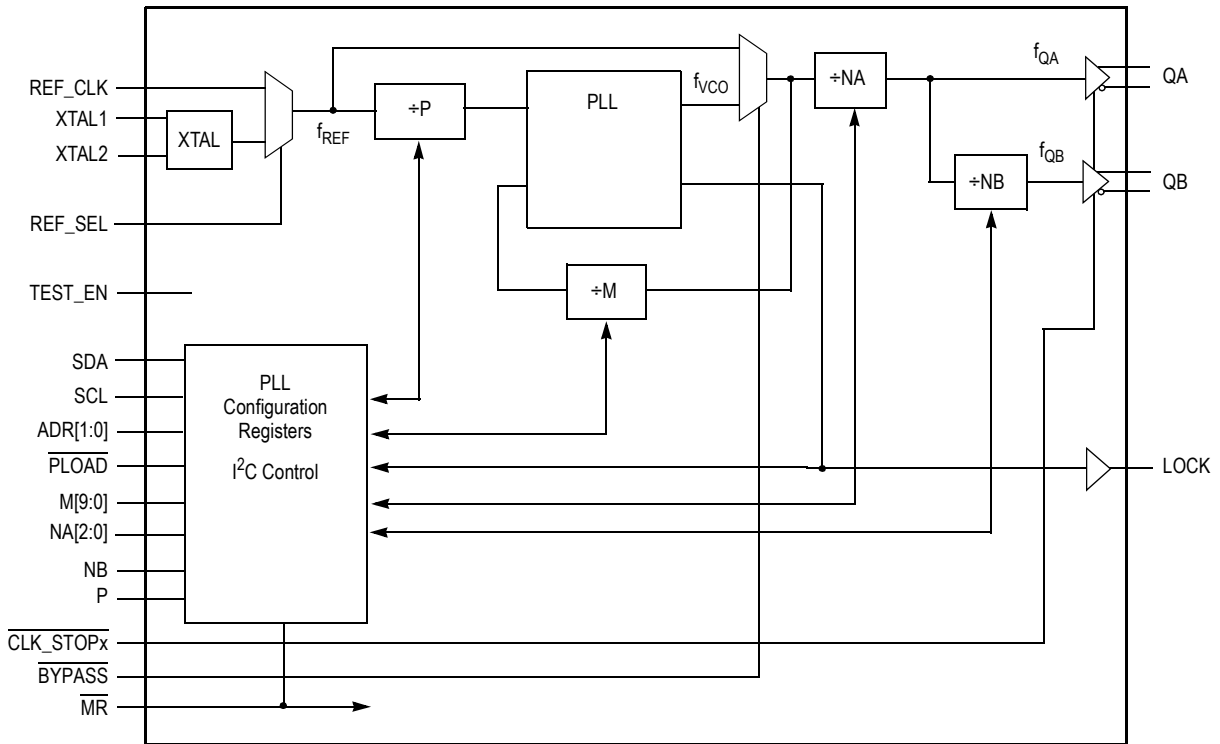

Figure 1. MPC92433-Generic Logic Diagram

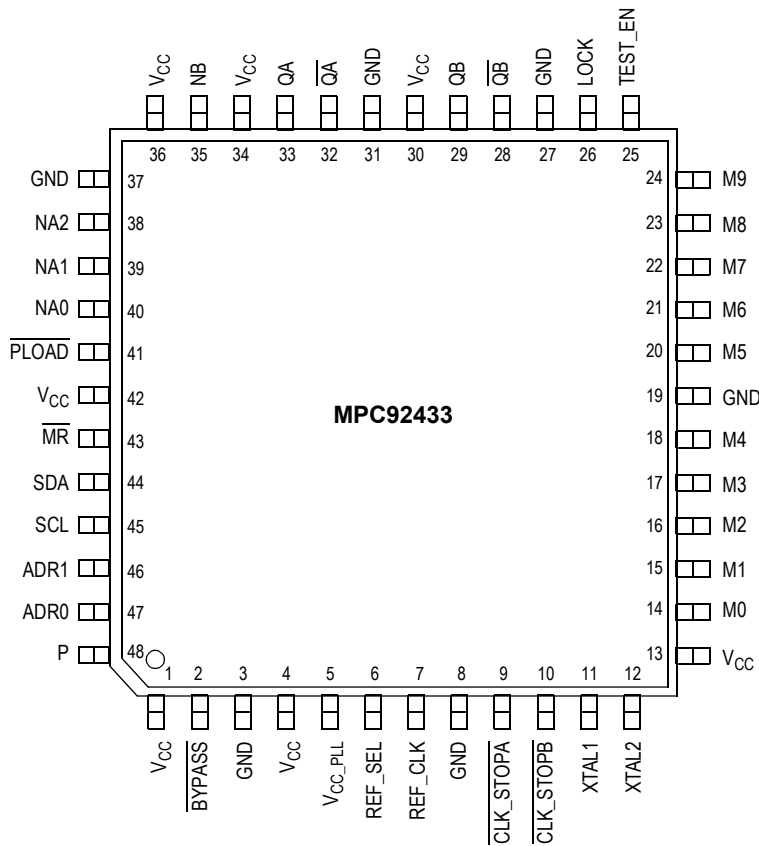

Figure 2. 48-Lead Package Pinout (Top View)

It is recommended to use an external RC filter for the analog V_{CC_PLL} supply pin. Please see the application section for details.

Table 1. Signal Configuration

Pin	I/O	Type	Function
XTAL1, XTAL2	Input	Analog	Crystal oscillator interface
REF_CLK	Input	LVC MOS	PLL external reference input
REF_SEL	Input	LVC MOS	Selects the reference clock input
QA	Output	Differential LVPECL	High frequency clock output
QB	Output	Differential LVPECL	High frequency clock output
LOCK	Output	LVC MOS	PLL lock indicator
M[9:0]	Input	LVC MOS	PLL feedback divider configuration
NA[2:0]	Input	LVC MOS	PLL post-divider configuration for output QA
NB	Input	LVC MOS	PLL post-divider configuration for output QB
P	Input	LVC MOS	PLL pre-divider configuration
$\overline{\text{P_LOAD}}$	Input	LVC MOS	Selects the programming interface
SDA	I/O	LVC MOS	I ² C data
SCL	Input	LVC MOS	I ² C clock
ADR[1:0]	Input	LVC MOS	Selectable two bits of the I ² C slave address
$\overline{\text{BYPASS}}$	Input	LVC MOS	Selects the static circuit bypass mode
TEST_EN	Input	LVC MOS	Factory test mode enable. This input must be set to logic low level in all applications of the device.
$\overline{\text{CLK_STOPx}}$	Input	LVC MOS	Output Qx disable in logic low state
$\overline{\text{MR}}$	Input	LVC MOS	Device master reset
GND	Supply	Ground	Negative power supply
V _{CC_PLL}	Supply	V _{CC}	Positive power supply for the PLL (analog power supply). It is recommended to use an external RC filter for the analog power supply pin V _{CC_PLL} .
V _{CC}	Supply	V _{CC}	Positive power supply for I/O and core

Table 2. Function Table

Control	Default ⁽¹⁾	0	1
Inputs			
REF_SEL	1	Selects REF_CLK input as PLL reference clock	Selects the XTAL interface as PLL reference clock
M[9:0]	01 1111 0100b ⁽²⁾	PLL feedback divider (10-bit) parallel programming interface	
NA[2:0]	010	PLL post-divider parallel programming interface. See Table 9	
NB	0	PLL post-divider parallel programming interface. See Table 9	
P	1	PLL pre-divider parallel programming interface. See Table 8	
$\overline{\text{PLOAD}}$	0	Selects the parallel programming interface. The internal PLL divider settings (M, NA, NB and P) are equal to the setting of the hardware pins. Leaving the M, NA, NB and P pins open (floating) results in a default PLL configuration with $f_{\text{OUT}} = 250$ MHz. See application/programming section.	Selects the serial (I ² C) programming interface. The internal PLL divider settings (M, NA, NB and P) are set and read through the serial interface.
ADR[1:0]	00	Address bit = 0	Address bit = 1
SDA, SCL		See Programming the MPC92433	
$\overline{\text{BYPASS}}$	1	PLL function bypassed $f_{\text{QA}} = f_{\text{REF}} \div N_{\text{A}}$ and $f_{\text{QB}} = f_{\text{REF}} \div (N_{\text{A}} \cdot N_{\text{B}})$	PLL function enabled $f_{\text{QA}} = (f_{\text{REF}} \div P) \cdot M \div N_{\text{A}}$ and $f_{\text{QB}} = (f_{\text{REF}} \div P) \cdot M \div (N_{\text{A}} \cdot N_{\text{B}})$
TEST_EN	0	Application mode. Test mode disabled.	Factory test mode is enabled
$\overline{\text{CLK_STOPx}}$	1	Output Qx is disabled in logic low state. Synchronous disable is only guaranteed if NB = 0.	Output Qx is synchronously enabled
$\overline{\text{MR}}$		The device is reset. The output frequency is zero and the outputs are asynchronously forced to logic low state. After releasing reset (upon the rising edge of $\overline{\text{MR}}$ and independent on the state of $\overline{\text{PLOAD}}$), the MPC92433 reads the parallel interface (M, NA, NB and P) to acquire a valid startup frequency configuration. See application/programming section.	The PLL attempts to lock to the reference signal. The t_{LOCK} specification applies.
Outputs			
LOCK		PLL is not locked	PLL is frequency locked

1. Default states are set by internal input pull-up or pull-down resistors of 75 k Ω .
2. If $f_{\text{REF}} = 16$ MHz, the default configuration will result in an output frequency of 250 MHz.

Table 3. General Specifications

Symbol	Characteristics	Min	Typ	Max	Unit	Condition
V_{TT}	Output Termination Voltage		$V_{CC} - 2$		V	
MM	ESD Protection (Machine Model)	200			V	
HBM	ESD Protection (Human Body Model)	2000			V	
LU	Latch-Up Immunity	200			mA	
C_{IN}	Input Capacitance		4.0		pF	Inputs
θ_{JA}	LQFP 48 Thermal Resistance Junction to Ambient JESD 51-3, single layer test board		69 64		$^{\circ}\text{C}/\text{W}$ $^{\circ}\text{C}/\text{W}$	Natural convection 200 ft/min
	JESD 51-6, 2S2P multilayer test board		53 50		$^{\circ}\text{C}/\text{W}$ $^{\circ}\text{C}/\text{W}$	Natural convection 200 ft/min
θ_{JC}	LQFP 48 Thermal Resistance Junction to Case		TBD	TBD	$^{\circ}\text{C}/\text{W}$	MIL-SPEC 883E Method 1012.1

Table 4. Absolute Maximum Ratings⁽¹⁾

Symbol	Characteristics	Min	Max	Unit	Condition
V_{CC}	Supply Voltage	-0.3	3.9	V	
V_{IN}	DC Input Voltage ⁽²⁾	-0.3	$V_{CC} + 0.3$	V	
V_{OUT}	DC Output Voltage	-0.3	$V_{CC} + 0.3$	V	
I_{IN}	DC Input Current		± 20	mA	
I_{OUT}	DC Output Current		± 50	mA	
T_S	Storage Temperature	-65	125	$^{\circ}\text{C}$	

1. Absolute maximum continuous ratings are those maximum values beyond which damage to the device may occur. Exposure to these conditions or conditions beyond those indicated may adversely affect device reliability. Functional operation at absolute-maximum-rated conditions is not implied.
2. All input pins including SDA and SCL pins.

Table 5. DC Characteristics ($V_{CC} = 3.3\text{ V} \pm 5\%$, $T_J = -40^\circ\text{C}$ to $+85^\circ\text{C}$)

Symbol	Characteristics	Min	Typ	Max	Unit	Condition
LVCMOS Control Inputs (M[9:0], N[2:0], ADDR[1:0], NB, P, CLK_STOPx, BYPASS, MR, REF_SEL, TEST_EN, PLOAD)						
V_{IH}	Input High Voltage	2.0	—	$V_{CC} + 0.3$	V	LVCMOS
V_{IL}	Input Low Voltage	—	—	0.8	V	LVCMOS
I_{IN}	Input Current ⁽¹⁾	—	—	± 200	μA	$V_{IN} = V_{CC}$ or GND
I ² C Inputs (SCL, SDA)						
V_{IH}	Input High Voltage	2.0	—	$V_{CC} + 0.3$	V	LVCMOS
V_{IL}	Input Low Voltage	—	—	0.8	V	LVCMOS
I_{IN}	Input Current	—	—	± 10	μA	
LVCMOS Output (LOCK)						
V_{OH}	Output High Voltage	2.4	—	—	V	$I_{OH} = -4\text{ mA}$
V_{OL}	Output Low Voltage	—	—	0.4	V	$I_{OL} = 4\text{ mA}$
I ² C Open-Drain Output (SDA)						
V_{OL}	Input Low Voltage	—	—	0.4	V	$I_{OL} = 4\text{ mA}$
Differential Clock Output QA, QB ⁽²⁾						
V_{OH}	Output High Voltage	$V_{CC} - 1.05$	—	$V_{CC} - 0.74$	V	LVPECL
V_{OL}	Output Low Voltage	$V_{CC} - 1.95$	—	$V_{CC} - 1.60$	V	LVPECL
$V_{O(P-P)}$	Output Peak-to-Peak Voltage	0.5	0.6	1.0	V	
Supply current						
I_{CC_PLL}	Maximum PLL Supply Current	—	—	10	mA	V_{CC_PLL} Pins
I_{CC}	Maximum Supply Current	—	—	150	mA	All V_{CC} Pins

1. Inputs have pull-down resistors affecting the input current.
2. Outputs terminated $50\ \Omega$ to $V_{TT} = V_{CC} - 2\text{ V}$.

Table 6. AC Characteristics ($V_{CC} = 3.3\text{ V} \pm 5\%$, $T_J = -40^\circ\text{C}$ to $+85^\circ\text{C}$ ⁽¹⁾ (2)

Symbol	Characteristics	Min	Typ	Max	Unit	Condition
f_{XTAL}	Crystal Interface Frequency Range	15	16	20	MHz	
f_{REF}	FREF_EXT Reference Frequency Range	15		20	MHz	
f_{VCO}	VCO Frequency Range ⁽³⁾	1360		2856	MHz	
f_{MAX}	Output Frequency ⁽⁴⁾	N= +2 680 N= +4 340 N= +6 226.67 N= +8 170 N= +12 113.30 N= +16 178.50 N= +32 42.50		1428 714 476 357 238 178.50 89.25	MHz MHz MHz MHz MHz MHz MHz	
f_{SCL}	Serial Interface (I ² C) Clock Frequency	0		0.4	MHz	
$t_{P,MIN}$	Minimum Pulse Width (P_LOAD)	50			ns	
DC	Output Duty Cycle	45	50	55	%	
$t_{SK(O)}$	Output-to-Output Skew NB=0 ($f_{QA} = f_{QB}$) NB=1 ($f_{QA} = 2 \cdot f_{QB}$)			38 96	ps ps	
t_r, t_f	Output Rise/Fall Time (QA, QB)	0.05		0.3	ns	20% to 80%
t_r, t_f	Output Rise/Fall Time (SDA)			250	ns	$C_L = 400\text{ pF}$
$t_{P,EN}$	Output Enable Time (CLKSTOPx to QA, QB)	0		$2 \cdot T_{Qx}$		$T_{Qx} = \text{Output period}$
$t_{P,DIS}$	Output Disable Time (CLKSTOPx to QA, QB)	0		$1.5 \cdot T_{Qx}$		$T_{Qx} = \text{Output period}$
$t_{JIT(CC)}$	Cycle-to-Cycle Jitter (RMS) ⁽⁵⁾	N= +2, +4, +6, +8 N= +12 N= +16, +32		15 20 30	ps ps ps	
$t_{JIT(PER)}$	Period Jitter (RMS) ⁽⁶⁾	N= +2 N= +4 N= +6 N= +8 N= +12 N= +16 N= +32		8 10 12 13 17 23 29	ps ps ps ps ps ps ps	
$N_{REF(UNLOCK)}$	Number of missing reference clock cycles to declare an out of LOCK condition ⁽⁷⁾	2				
t_{LOCK}	Maximum PLL Lock Time			10	ms	

1. AC specifications are subject to change.

2. AC characteristics apply for parallel output termination of $50\ \Omega$ to V_{TT} .

3. The input frequency f_{XTAL} , the PLL divider M and P must match the VCO frequency range: $f_{VCO} = f_{XTAL} \cdot M \div P$. The feedback divider M is limited to $170 \leq M \leq 357$ (for P=2) and $340 \leq M \leq 714$ (for P=4) for stable PLL operation.

4. Output frequency for Q_A, Q_B if N_B=0. With N_B=1 the Q_B output frequency is half of the Q_A output frequency.

5. Maximum cycle jitter measured at the lowest VCO frequency. Refer to Figure 8 for the cycle jitter vs. frequency characteristics.

6. Maximum period jitter measured at the lowest VCO frequency. Refer to Figure 9 for the period jitter vs. frequency characteristics.

7. See the [LOCK Detect](#) section on page 13.

Output Frequency Configuration

The MPC92433 is a programmable frequency source (synthesizer) and supports an output frequency range of 42.5 – 1428 MHz. The output frequency f_{OUT} is a function of the reference frequency f_{REF} and the three internal PLL dividers P, M, and N. f_{OUT} can be represented by this formula:

$$f_{OUT} = (f_{REF} \div P) \cdot M \div (N_A \cdot B) \quad (1)$$

The M, N and P dividers require a configuration by the user to achieve the desired output frequency. The output divider, N_A , determines the achievable output frequency range (see [Table 7](#)). The PLL feedback-divider M is the frequency multiplication factor and the main variable for frequency synthesis. For a given reference frequency f_{REF} , the PLL feedback-divider M must be configured to match the specified VCO frequency range in order to achieve a valid PLL configuration:

$$f_{VCO} = (f_{REF} \div P) \cdot M \text{ and} \quad (2)$$

$$1360 \leq f_{VCO} \leq 2856 \quad (3)$$

The output frequency may be changed at any time by changing the value of the PLL feedback divider M. The smallest possible output frequency change is the synthesizer granularity G (difference in f_{OUT} when incrementing or decrementing M). At a given reference frequency, G is a function of the PLL pre-divider P and post-divider N:

$$G = f_{REF} \div (P \cdot N_{A,B}) \quad (4)$$

The N_B divider configuration determines if the output Q_B generates a 1:1 or 2:1 frequency copy of the Q_A output signal. The purpose of the PLL pre-divider P is to situated the PLL into the specified VCO frequency range f_{VCO} (in combination with M). For a given output frequency, $P = 4$ results in a smaller output frequency granularity G, $P = 2$ results a larger output frequency granularity G and also increases the PLL bandwidth compared to the $P = 2$ setting.

The following example illustrates the output frequency range of the MPC92433 using a 16-MHz reference frequency.

Table 7. Frequency Ranges ($f_{REF}=16$ MHz)

$f_{OUT} (Q_A)$ [MHz]	N_A	M	P	G [MHz]
680–1428	$N_A=2$	170-357	2	4
		340-714	4	2
340–714	$N_A=4$	170-357	2	2
		340-714	4	1
226.67–476	$N_A=6$	170-357	2	1.33
		340-714	4	0.66
170–357	$N_A=8$	170-357	2	1
		340-714	4	0.5
113.33–238	$N_A=12$	170-357	2	0.66
		340-714	4	0.33
85–178.5	$N_A=16$	170-357	2	0.5
		340-714	4	0.25
42.5–89.25	$N_A=32$	170-357	2	0.25
		340-714	4	0.125

Example Output Frequency Configuration

If a reference frequency of 16 MHz is available, an output frequency at Q_A of 250 MHz and a small frequency granularity is desired, the following steps would be taken to identify the appropriate P, M, and N configuration:

- Use [Table 7](#) to select the output divider, N_A , that matches the desired output frequency or frequency range. According to [Table 7](#), a target output frequency of 250 MHz falls in the f_{OUT} range of 170 to 357 MHz and requires to set $N_A = 8$
- Calculate the VCO frequency $f_{VCO} = f_{OUT} \cdot N_A$, which is 2000 MHz in this example.
- Determine the PLL feedback divider: $M = f_{VCO} \div P$. The smallest possible output granularity in this example calculation is 500 kHz (set $P = 4$). M calculates to a value of $2000 \div 4 = 500$.
- Configure the MPC92433 with the obtained settings:
 - $M[9:0] = 0111110100b$ (binary number for $M=500$)
 - $N_A[2:0] = 010$ ($\div 8$ divider, see [Table 9](#))
 - $P = 1$ ($\div 4$ divider, see [Table 8](#))
 - $N_B = 0$ ($f_{OUT, QB} = f_{OUT, QA}$)
- Use either parallel or serial interface to apply the setting. The I²C configuration bytes for this example are:
 - PLL_H=01010010b and PLL_L=11110100b.
 See [Table 13](#) and [Table 14](#) for register maps.

PLL Divider Configuration

Table 8. Pre-PLL Divider P

P	Value
0	$f_{REF} \div 2$
1	$f_{REF} \div 4$

Table 9. Post-PLL Divider N_A and N_B

N_{A2}	N_{A1}	N_{A0}	N_B	$f_{OUT}(Q_A)$	$f_{OUT}(Q_B)$
0	0	0	0	$f_{VCO} \div 2$	$f_{VCO} \div 2$
0	0	1	0	$f_{VCO} \div 32$	$f_{VCO} \div 32$
0	1	0	0	$f_{VCO} \div 8$	$f_{VCO} \div 8$
0	1	1	0	$f_{VCO} \div 12$	$f_{VCO} \div 12$
1	0	0	0	$f_{VCO} \div 4$	$f_{VCO} \div 4$
1	0	1	0	$f_{VCO} \div 6$	$f_{VCO} \div 6$
1	1	0	0	$f_{VCO} \div 16$	$f_{VCO} \div 16$
1	1	1	0	n/a	n/a
0	0	0	1	$f_{VCO} \div 2$	$f_{VCO} \div 4$
0	0	1	1	n/a	n/a
0	1	0	1	$f_{VCO} \div 8$	$f_{VCO} \div 16$
0	1	1	1	n/a	n/a
1	0	0	1	$f_{VCO} \div 4$	$f_{VCO} \div 8$
1	0	1	1	$f_{VCO} \div 6$	$f_{VCO} \div 12$
1	1	0	1	$f_{VCO} \div 16$	$f_{VCO} \div 32$
1	1	1	1	n/a	n/a

Programming the MPC92433

The MPC92433 has a parallel and a serial configuration interface. The purpose of the parallel interface is to directly configure the PLL dividers through hardware pins without the overhead of a serial protocol. At device startup, the device always obtains an initial PLL frequency configuration through the parallel interface. The parallel interface does not support reading the PLL configuration.

The serial interface is I²C compatible. It allows reading and writing devices settings by accessing internal device registers. The serial interface is designed for host-controller access to the synthesizer frequency settings for instance in frequency-margining applications.

Using the Parallel Interface

The parallel interface supports write-access to the PLL frequency setting directly through 15 configuration pins (P, M[9:0], NA[2:0], and NB). The parallel interface must be enabled by setting PLOAD to logic low level. During PLOAD = 0, any change of the logical state of the P, M[9:0], NA[2:0], and NB pins will immediately affect the internal PLL divider settings, resulting in a change of the internal VCO-frequency and the output frequency. The parallel interface mode disables the I²C write-access to the internal registers; however, I²C read-access to the internal configuration registers is enabled.

Upon startup, when the device reset signal is released (rising edge of the MR signal), the device reads its startup configuration through the parallel interface and independent on the state of PLOAD. It is recommended to provide a valid PLL configuration for startup. If the parallel interface pins are left open, a default PLL configuration will be loaded. After the low-to-high transition of PLOAD, the configuration pins have no more effect and the configuration registers are made accessible through the serial interface.

Table 10. Feedback Divider Configuration

Feedback Divider M	9	8	7	6	5	4	3	2	1	0
Pin	M9	M8	M7	M6	M5	M4	M3	M2	M1	M0
Default	0	1	1	1	1	1	0	1	0	0

Table 11. PLL Pre/Post Divider Configuration (N, P)

Post-D. NA	2	1	0	Post-D. NB	NB	Pre-D. P	P
Pin	NA2	NA1	NA0	Pin	NB	Pin	P
Default	0	1	0	Default	0	Default	1

Using the I²C Interface

PLOAD = 1 enables the programming and monitoring of the internal registers through the I²C interface. Device register access (write and read) is possible through the 2-wire interface using SDA (configuration data) and SCL (configuration clock) signals. The MPC92433 acts as a slave device at the I²C bus. For further information on I²C it is recommended to refer to the I²C bus specification (version 2.1).

PLOAD = 0 disables the I²C-write-access to the configuration registers and any data written into the register is ignored. However, the MPC92433 is still visible at the I²C interface and I²C transfers are acknowledged by the device. Read-access to the internal registers during PLOAD = 0 (parallel programming mode) is supported.

Note that the device automatically obtains a configuration using the parallel interface upon the release of the device reset (rising edge of MR) and independent on the state of PLOAD. Changing the state of the PLOAD input is not supported when the device performs any transactions on the I²C interface.

Programming Model and Register Set

The synthesizer contains two fully accessible configuration registers (PLL_L and PLL_H) and a write-only command register (CMD). Programming the synthesizer frequency through the I²C interface requires two steps: 1) writing a valid PLL configuration to the configuration registers and 2) loading the registers into the PLL by an I²C command. The PLL frequency is affected as a result of the second step.

This two-step procedure can be performed by a single I²C transaction or by multiple, independent I²C transactions. An alternative way to achieve small PLL frequency changes is to use the increment or decrement commands of the

synthesizer, which have an immediate effect on the PLL frequency.

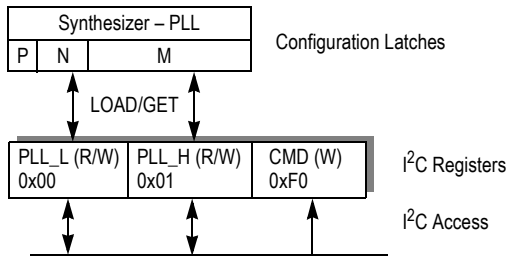

Figure 3. I²C Mode Register Set

Figure 3 illustrates the synthesizer register set. PLL_L and PLL_H store a PLL configuration and are fully accessible (Read/Write) by the I²C bus. CMD (Write only) accepts commands (LOAD, GET, INC, DEC) to update registers and for direct PLL frequency changes.

Set the synthesizer frequency:

- 1) Write the PLL_L and PLL_H registers with a new configuration (see Table 13 and Table 14 for register maps)
- 2) Write the LOAD command to update the PLL dividers by the current PLL_L, PLL_H content.

Read the synthesizer frequency:

- 1) Write the GET commands to update the PLL_L, PLL_H registers by the PLL divider setting
- 2) Read the PLL_L, PLL_H registers through I²C

Change the synthesizer frequency in small steps:

- 1) Write the INC or DEC command to change the PLL frequency immediately. Repeat at any time if desired.

LOAD and GET are inverse command to each other. LOAD updates the PLL dividers and GET updates the configuration registers. A fast and convenient way to change the PLL frequency is to use the INC (increment M) and DEC (decrement M) commands of the synthesizer. INC (DEC) directly increments (decrements) the PLL-feedback divider M and immediately changes the PLL frequency by the smallest step G (see Table 7 for the frequency granularity G). The INC and DEC commands are designed for multiple and rapid PLL frequency changes as required in frequency margining applications. INC and DEC do not require the user to update the PLL dividers by the LOAD command, INC and DEC do not update the PLL_L and PLL_H registers either (use LOAD for an initial PLL divider setting and, if desired, use GET to read the PLL configuration). Note that the synthesizer does not check any boundary conditions such as the VCO frequency range. Applying the INC and DEC commands could result in invalid VCO frequencies (VCO frequency beyond lock range).

Register Maps

Table 12. Configuration Registers

Address	Name	Content	Access
0x00	PLL_L	Least significant 8 bits of M	R/W
0x01	PLL_H	Most significant 2 bits of M, P, N _A , N _B , and lock state	R/W
0xF0	CMD	Command register (write only)	W only

Register 0x00 (PLL_L) contains the least significant bits of the PLL feedback divider M.

Table 13. PLL_L (0x00, R/W) Register

Bit	7	6	5	4	3	2	1	0
Name	M7	M6	M5	M4	M3	M2	M1	M0

Register content:

M[7:0] PLL feedback-divider M, bits 7–0

Register 0x01 (PLL_H) contains the two most significant bits of the PLL feedback divider M, four bits to control the PLL post-dividers N and the PLL pre-divider P. The bit 0 in PLL_H register indicates the lock condition of the PLL and is set by the synthesizer automatically. The LOCK state is a copy of the PLL lock signal output (LOCK). A write-access to LOCK has no effect.

Table 14. PLL_H (0x01, R/W) Register

Bit	7	6	5	4	3	2	1	0
Name	M9	M8	NA2	NA1	NA0	NB	P	LOCK

Register content:

M[9:8] PLL feedback-divider M, bits 9–8

NA[2:0] PLL post-divider N_A, see Table 9

NB PLL post-divider N_B, see Table 9

P PLL pre-divider P, see Table 8

LOCK Copy of LOCK output signal (read-only)

Note that the LOAD command is required to update the PLL dividers by the content of both PLL_L and PLL_H registers.

Register 0xF0 (CMD) is a write-only command register. The purpose of CMD is to provide a fast way to increase or decrease the PLL frequency and to update the registers. The register accepts four commands, INC (increment M), DEC (decrement M), LOAD and GET (update registers). It is recommended to write the INC, DEC commands only after a valid PLL configuration is achieved. INC and DEC only affect the M-divider of the PLL (PLL feedback). Applying INC and DEC commands can result in a PLL configuration beyond the specified lock range and the PLL may lose lock. The MPC92433 does not verify the validity of any commands such as LOAD, INC, and DEC. The INC and DEC commands change the PLL feedback divider without updating PLL_L and PLL_H.

Table 15. CMD (0xF0): PLL Command (Write-Only)

Command	Op-Code	Description
INC	xxxx0001b (0x01)	Increase internal PLL frequency M:=M+1
DEC	xxxx0010b (0x02)	Decrease internal PLL frequency M:=M-1
LOAD	xxxx0100b (0x04)	Update the PLL divider config. PLL divider M, N, P:=PLL_L, PLL_H
GET	xxxx1000b (0x08)	Update the configuration registers PLL_L, PLL_H:=PLL divider M, N, P

I²C — Register Access in Parallel Mode

The MPC92433 supports the configuration of the synthesizer through the parallel interface (PLOAD = 0) and serial interface (PLOAD = 1). Register contents and the divider configurations are not changed when the user switches from parallel mode to serial mode. However, when switching from serial mode to parallel mode, the PLL dividers immediately reflect the logical state of the hardware pins M[9:0], NA[2:0], NB, and P.

Applications using the parallel interface to obtain a PLL configuration can use the serial interface to verify the divider settings. In parallel mode (PLOAD = 0), the MPC92433 allows read-access to PLL_L and PLL_H through I²C (if PLOAD = 0, the current PLL configuration is stored in PLL_L, PLL_H. The GET command is not necessary and also not supported in parallel mode). After changing from parallel to serial mode (PLOAD = 1), the last PLL configuration is still stored in PLL_L, PLL_H. The user now has full write and read access to both configuration registers through the I²C bus and can change the configuration at any time.

Table 16. PLL Configuration in Parallel and Serial Modes

PLL Configuration	Parallel	Serial (Registers PLL_L, PLL_H)
M[9:0]	Set pins M9–M0	M[9:0] (R/W)
NA[2:0]	Set pins NA2...NA0	NA[2:0] (R/W)
NB	Set pin NB	NB (R/W)
P	Set pin P	P (R/W)
LOCK status	LOCK pin 26	LOCK (Read only)

Programming the I²C Interface

Table 17. I²C Slave Address

Bit	7	6	5	4	3	2	1	0
Value	1	0	1	1	0	Pin ADR1	Pin ADR0	R/W

The 7-bit I²C slave address of the MPC92433 synthesizer is a combination of a 5-bit fixed addresses and two variable bits which are set by the hardware pins ADR[1:0]. Bit 0 of the MPC92433 slave address is used by the bus controller to select either the read or write mode. '0' indicates a transmission (I²C-WRITE) to the MPC92433. '1' indicates a request for data (I²C-READ) from the synthesizer. The hardware pins ADR1 and ADR0 and should be individually set by the user to avoid address conflicts of multiple MPC92433 devices on the same I²C bus.

Write Mode (R/W = 0)

The configuration registers are written by the bus controller by the initiation of a write transfer with the MPC92433 slave address (first byte), followed by the address of the configuration register (second byte: 0x00, 0x01 or 0xF0), and the configuration data byte (third byte). This transfer may be followed by writing more registers by sending the configuration register address followed by one data byte. Each byte sent by the bus controller is acknowledged by the MPC92433. The transfer ends by a stop bit sent by the bus controller. The number of configuration data bytes and the write sequence are not restricted.

Table 18. Complete Configuration Register Write Transfer

1 bit	7 bits	1 bit	1 bit	8 bits	1 bit	8 bits	1 bit	8 bits	1 bit	8 bits	1 bit	1 bit
Start	Slave address	R/W	ACK	&PLL_H	ACK	Config-Byte 1	ACK	&PLL_L	ACK	Config-Byte 2	ACK	Stop
	10110xx ⁽¹⁾	0		0x01		Data		0x00		Data		
Master	Master	Mast	Slave	Master	Slave	Master	Slave	Master	Slave	Master	Slave	Mast

1. xx = state of ADR1, ADR0 pins

Read Mode (R/W = 1)

The configuration registers are read by the bus controller by the initiation of a read transfer. The MPC92433 supports read transfers immediately after the first byte without a change in the transfer direction. Immediately after the bus controller sends the slave address, the MPC92433 acknowledges and then sends both configuration register PLL_L and PLL_H (back-to-back) to the bus controller. The CMD register cannot be read. In order to read the two synthesizer registers and the current PLL configuration setting, the user can 1) read PLL_L, PLL_H, write the GET

command (loads the current configuration into PLL_L, PLL_H) and read PLL_L, PLL_H again. Note that the PLL_L, PLL_H registers and divider settings may not be equivalent after the following cases:

- Writing the INC command
- Writing the DEC command
- Writing PLL_L, PLL_H registers with a new configuration and not writing the LOAD command.

Table 19. Configuration Register Read Transfer

1 bit	7 bits	1 bit	1 bit	8 bits	1 bit	8 bits	1 bit	1 bit
Start	Slave address	R/W	ACK	PLL_L	ACK	PLL_H	ACK	Stop
	10110xx ⁽¹⁾	1		Data		Data		
Master	Master	Mast	Slave	Slave	Mast	Slave	Master	Slave

1. xx = state of ADR1, ADR0 pins

Device Startup

General Device Configuration

It is recommended to reset the MPC92433 during or immediately after the system powers up ($\overline{MR} = 0$). The device acquires an initial PLL divider configuration through the parallel interface pins M[9:0], NA[2:0], N, and P⁽¹⁾ with the low-to-high transition of \overline{MR} ⁽²⁾. PLL frequency lock is achieved within the specified lock time (t_{LOCK}) and is indicated by an assertion of the LOCK signal which completes the startup procedure. It is recommended to disable the outputs ($CLK_STOPx = 0$) until PLL lock is achieved to suppress output frequency transitions. The output frequency can be reconfigured at any time through either the parallel or the serial interface.

Note that a PLL configuration obtained by the parallel interface can be read through I²C independent on the current programming mode (parallel or serial). Refer to the **I²C — Register Access in Parallel Mode** section for additional information on how to read a PLL startup configuration through the I²C interface.

Starting-Up Using the Parallel Interface

The simplest way to use the MPC92433 is through the parallel interface. The serial interface pins (SDA, SDL) and ADDR[1:0]) can be left open and \overline{PLOAD} is set to logic low. After the release of \overline{MR} and at any other time the PLL/output frequency configuration is directly set to through the M[9:0], NA[2:0], NB, and P pins.

Start-Up Using the Serial (I²C) Interface

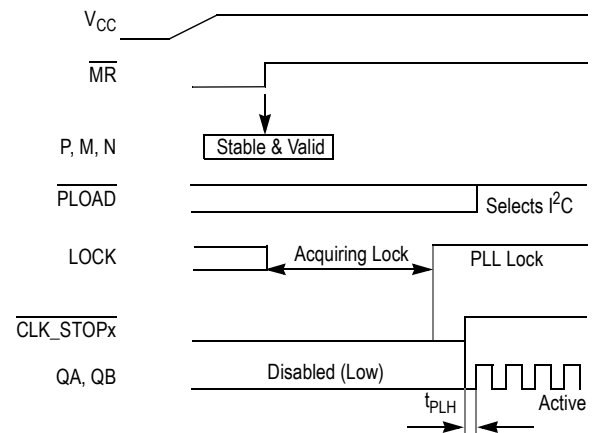

Figure 4. Start-Up Using I²C Interface

Set $\overline{PLOAD} = 1$, $\overline{CLK_STOPx} = L$ and leave the parallel interface pins (M[9:0], NA[2:0], N, and P) open. The PLL dividers are configured by the default configuration at the low-to-high transition of \overline{MR} . This initial PLL configuration can be re-programmed to the final VCO frequency at any time through the serial interface. After the PLL achieved lock at the desired VCO frequency, enable the outputs by setting $\overline{CLK_STOPx} = H$. PLL lock and re-lock (after any configuration change through M or P) is indicated by LOCK being asserted.

- The parallel interface pins M[9:0], NA[2:0], N, and P may be left open (floating). In this case the initial PLL configuration will have the default setting of M = 500, P = 1, NA[2:0] = 010, NB = 0, resulting in an internal VCO frequency of 2000 MHz ($f_{ref} = 16$ MHz) and an output frequency of 250 MHz.
- The initial PLL configuration is independent on the selected programming mode (\overline{PLOAD} low or high)

LOCK Detect

The LOCK detect circuitry indicates the frequency-lock status of the PLL by setting and resetting the pin LOCK and register bit LOCK simultaneously. After acquiring an internal frequency lock state, the assertion of the LOCK signal is delayed at least 256 reference clock cycles to prevent signaling temporary PLL locks during frequency transitions. The LOCK signal is deasserted when the PLL lost lock, for instance when the reference clock is removed: the LOCK signal goes low after missing at least two f_{ref} clock cycles ($N_{REF(UNLOCK)}$). The PLL may also lose lock when the PLL feedback-divider M or pre-divider P is changed or the DEC/INC command is issued. The PLL may not lose lock as a result of slow reference frequency changes. In any case of losing LOCK, the PLL attempts to re-lock to the reference frequency.

Output Clock Stop

Asserting $\overline{CLK_STOPx}$ will stop the respective output clock in logic low state. The $\overline{CLK_STOPx}$ control is internally synchronized to the output clock signal, therefore, enabling and disabling outputs does not produce runt pulses. See Figure 5. The clock stop controls of the QA and QB outputs are independent on each other. If the QB runs at half of the QA output frequency and both outputs are enabled at the same time, the first clock pulse of QA may not appear at the same time of the first QB output. (See Figure 6.) Coincident rising edges of QA and QB stay synchronous after the assertion and de-assertion of the $\overline{CLK_STOPx}$ controls. Asserting \overline{MR} always resets the output divider to a logic low output state, with the risk of producing an output runt pulse.

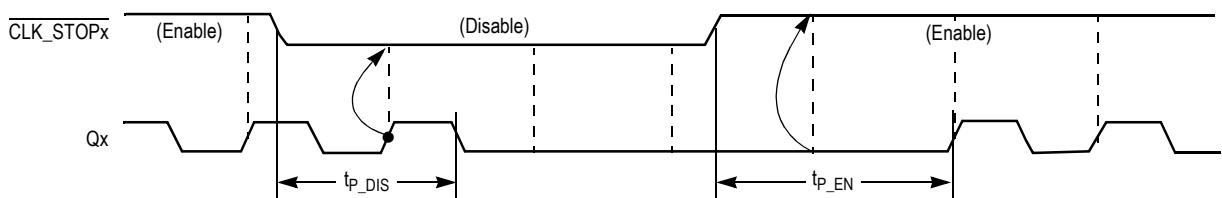

Figure 5. Clock Stop Timing for NB = 0 ($f_{QA} = f_{QB}$)

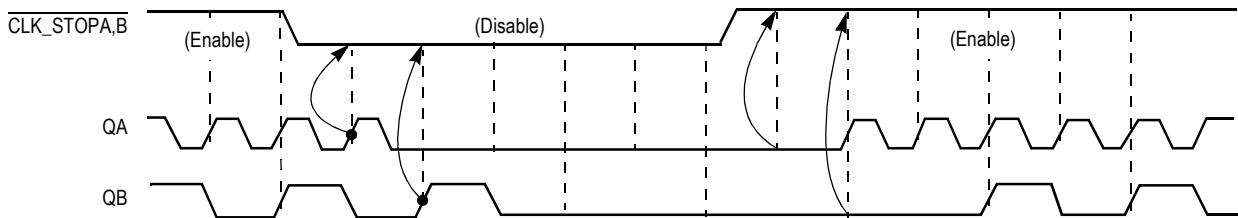

Figure 6. Clock Stop Timing for NB = 1 ($f_{QA} = 2 f_{QB}$)

Frequency Operating Range

Table 20. MPC92433 Frequency Operating Range for P=2

M	M[9:0]	f _{VCO} [MHz] (parameter: f _{REF} in MHz)				Output frequency for f _{XTAL} =16 MHz (parameter N)						
		15	16	18	20	2	4	6	8	12	16	32
170	0010101010		1360	1530	1700	680	340	226.67	170	113.33	85	42.50
180	0010110100		1440	1620	1800	720	360	240.00	180	120.00	90	45.00
190	0010111110	1425	1520	1710	1900	760	380	253.33	190	126.67	95	47.50
200	0011001000	1500	1600	1800	2000	800	400	266.67	200	133.33	100	50.00
210	0011010010	1575	1680	1890	2100	840	420	280.00	210	140.00	105	52.50
220	0011011100	1650	1760	1980	2200	880	440	293.33	220	146.67	110	55.00
230	0011100110	1725	1840	2070	2300	920	460	306.67	230	153.33	115	57.50
240	0011110000	1800	1920	2160	2400	960	480	320.00	240	160.00	120	60.00
250	0011111010	1875	2000	2250	2500	1000	500	333.33	250	166.67	125	62.50
260	0100000100	1950	2080	2340	2600	1040	520	346.67	260	173.33	130	65.00
270	0100001110	2025	2160	2430	2700	1080	540	360.00	270	180.00	135	67.50
280	0100011000	2100	2240	2520	2800	1120	560	373.33	280	186.67	140	70.00
290	0100100010	2175	2320	2610		1160	580	386.67	290	193.33	145	72.50
300	0100101100	2250	2400	2700		1200	600	400.00	300	200.00	150	75.00
310	0100110110	2325	2480	2790		1240	620	413.33	310	206.67	155	77.50
320	0101000000	2400	2560			1280	640	426.67	320	213.33	160	80.00
330	0101001010	2475	2640			1320	660	440.00	330	220.00	165	82.50
340	0101010100	2550	2720			1360	680	453.33	340	226.67	170	85.00
350	0101011110	2625	2800			1400	700	466.67	350	233.33	175	87.50
357	0101100101	2667.5	2856			1428	714	476.00	357	238.00	178.50	89.25

Table 21. MPC92433 Frequency Operating Range for P=4

M	M[9:0]	f _{VCO} [MHz] (parameter: f _{REF} in MHz)				Output frequency for f _{XTAL} =16 MHz (parameter N)						
		15	16	18	20	2	4	6	8	12	16	32
340	0101010100		1360	1530	1700	680	340	226.67	170	113.33	85.0	42.50
350	0101011110		1400	1575	1750	700	350	233.33	175	116.67	87.5	43.75
360	0101101000		1440	1620	1800	720	360	240.00	180	120.00	90.0	45.00
370	0101110010	1387.5	1480	1665	1850	740	370	246.67	185	123.33	92.5	46.25
380	0101111100	1425.0	1520	1710	1900	760	380	253.33	190	126.67	95.0	47.50
390	0110000110	1462.5	1560	1755	1950	780	390	260.00	195	130.00	97.5	48.75
400	0110010000	1500.0	1600	1800	2000	800	400	266.67	200	133.33	100.0	50.00
410	0110110010	1537.5	1640	1845	2050	820	410	273.33	205	136.67	102.5	51.25
420	0110100100	1575.0	1680	1890	2100	840	420	280.00	210	140.00	105.0	52.50
430	0110101110	1612.5	1720	1935	2150	860	430	286.67	215	143.33	107.5	53.75
440	0110111000	1650.0	1760	1980	2200	880	440	293.33	220	146.67	110.0	55.00
450	0111000010	1687.5	1800	2025	2250	900	450	300.00	225	150.00	112.5	56.25
460	0111001100	1725.0	1840	2070	2300	920	460	306.67	230	153.33	115.0	57.50
470	0111010110	1762.5	1880	2115	2350	940	470	313.33	235	156.67	117.5	58.75
480	0111100000	1800.0	1920	2160	2400	960	480	320.00	240	160.00	120.0	60.00
490	0111101010	1837.5	1960	2205	2450	980	490	326.67	245	163.33	122.5	61.25
500	0111110100	1875.0	2000	2250	2500	1000	500	333.33	250	166.67	125.0	62.50
510	0111111110	1912.5	2040	2295	2550	1020	510	340.00	255	170.00	127.5	63.75
520	1000001000	1950.0	2080	2340	2600	1040	520	346.67	260	173.33	130.0	65.00
530	1000010010	1987.5	2120	2475	2650	1060	530	353.33	265	176.67	132.5	66.25
540	1000011100	2025.0	2160	2520	2700	1080	540	360.00	270	180.00	135.0	67.50
550	1000100110	2062.5	2200	2565	2750	1100	550	366.67	275	183.33	137.5	68.75
560	1000110000	2100.0	2240	2610	2800	1120	560	373.33	280	186.67	140.0	70.00
570	1000111010	2137.5	2280	2565	2850	1140	570	380.00	285	190.00	142.5	71.25
580	1001000100	2175.0	2320	2610		1160	580	386.67	290	193.33	145.0	72.50
590	1001001110	2212.5	2360	2655		1180	590	393.33	295	196.67	147.5	73.75
600	1001011000	2250.0	2400	2700		1200	600	400.00	300	200.00	150.0	75.00
610	1001100010	2287.5	2440	2745		1220	610	406.67	305	203.33	152.5	76.25
620	1001101100	2325.0	2480	2790		1240	620	413.33	310	206.67	155.0	77.50
630	1001110110	2362.5	2520	2835		1260	630	420.00	315	210.00	157.5	78.75 [^]
640	1010000000	2400.0	2560			1280	640	426.67	320	213.33	160.0	80.00
650	1010001010	2437.5	2600			1300	650	433.33	325	216.67	162.5	81.25
660	1010010100	2475.0	2640			1320	660	440.00	330	220.00	165	82.5
670	1010011110	2512.5	2680			1340	670	446.67	335	223.33	167.5	83.75
680	1010101000	2550.0	2720			1360	680	453.33	340	226.67	170.0	85.00
690	1010110010	2587.5	2760			1380	690	460.00	345	230.00	172.5	86.25
700	1010111100	2625.0	2800			1400	700	466.67	350	233.33	175.0	87.50
714	1011001010	2677.5	2856			1428	714	476.00	357	238.00	178.5	89.25

V_{CC_PLL} Filter

The MPC92433 is a mixed analog/digital product. Its analog circuitry is naturally susceptible to random noise, especially if this noise is seen on the power supply pins. Random noise on the V_{CC_PLL} pin impacts the device AC characteristics. The MPC92433 provides separate power supplies for the digital circuitry (V_{CC}) and the internal PLL (V_{CC_PLL}) of the device. The purpose of this design technique is to isolate the high switching noise digital outputs from the relatively sensitive internal analog phase-locked loop. In digital system environments where it is more difficult to minimize noise on the power supplies a second level of isolation is recommended: a power supply filter on the V_{CC_PLL} pin for the MPC92433.

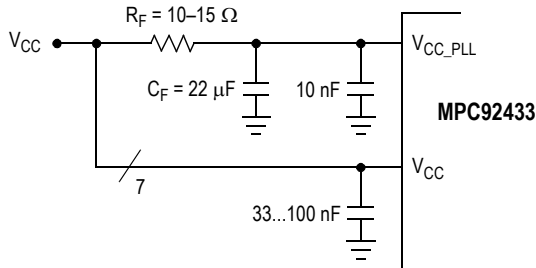

Figure 7. V_{CC_PLL} Power Supply Filter

Figure 7 illustrates a recommended power supply filter scheme.

The MPC92433 is most susceptible to noise with spectral content in the 100 kHz to 1 MHz range. Therefore, the filter should be designed to target this range. The key parameter that needs to be met in the final filter design is the DC voltage drop that will be seen between the V_{CC} supply and the V_{CC_PLL} pin of the MPC92433. From the data sheet, the V_{CC_PLL} current (the current sourced through the V_{CC_PLL} pin) is maximum 10 mA, assuming that a minimum of 2.985 V must be maintained on the V_{CC_PLL} pin. The resistor shown in Figure 7 must have a resistance of 10–15 Ω to meet the voltage drop criteria. The minimum values for R_F and the filter capacitor C_F are defined by the filter characteristics: the RC

filter should provide an attenuation greater than 40 dB for noise whose spectral content is above 100 kHz. In the recommended filter shown in Figure 7 the filter cut-off frequency is around 3.0–4.5 kHz and the noise attenuation at 100 kHz is better than 42 dB.

As the noise frequency crosses the series resonant point of an individual capacitor its overall impedance begins to look inductive and thus increases with increasing frequency. The parallel capacitor combination shown ensures that a low impedance path to ground exists for frequencies well above the bandwidth of the PLL.

The On-Chip Crystal Oscillator

The MPC92433 features an integrated on-chip crystal oscillator to minimize system implementation cost. The integrated oscillator is a Pierce-type that uses the crystal in its parallel resonance mode. It is recommended to use a 15 to 20 MHz crystal with a load specification of C_L = 10 pF. Crystals with a load specification of C_L = 20 pF may be used at the expense of an resulting slightly higher frequency than specified for the crystal. Externally connected capacitors on both the XTAL_IN and XTAL_OUT pins are not required but can be used to fine-tune the crystal frequency as desired.

The crystal, the trace and optional capacitors should be placed on the board as close as possible to the MPC92433 XTAL_IN and XTAL_OUT pins to reduce crosstalk of active signals into the oscillator. Short and wide traces further reduce parasitic inductance and resistance. It is further recommended to guard the crystal circuit by placing a ground ring around the traces and oscillator components.

Table 22. Recommended Crystal Specifications

Parameter	Value
Crystal Cut	Fundamental AT Cut
Resonance Mode	Parallel
Crystal Frequency	16–20 MHz
Shunt Capacitance C ₀	5–7 pF
Load Capacitance C _L	10 pF

Jitter Performance of the MPC92433

Figure 8 and Figure 9 illustrate the RMS jitter performance of the MPC92433 across its specified VCO frequency range. For some output dividers N, the cycle-to-cycle and period jitter is a function of the VCO frequency and the output divider N. The general trend is that as the output frequency increases (higher VCO frequency and lower N-divider) the MPC92433 output jitter decreases. Optimum jitter performance can be achieved at higher VCO and output frequencies.

For the output dividers of N=2, 4 and 6 the cycle-to-cycle jitter does not depend on the VCO frequency. For the output dividers of 2, 4 and 8 the period jitter does not depend on the VCO frequency. The maximum cycle-to-cycle and period jitter published in Table 6 (AC characteristics) correspond to the jitter performance at the lowest VCO frequency limit. The VCO frequency can be calculated using formula (2).

AC Test Reference and Output Termination

The MPC92433 LVPECL outputs are designed to drive 50 transmission lines and require a DC termination to $V_{TT} = V_{CC} - 2\text{ V}$. Figure 10 illustrates the AC test reference for the MPC92433 as used in characterization and test of this circuit. If a separate termination voltage (V_{TT}) is not available, applications may use alternative output termination methods such as shown in Figure 11 and Figure 12.

The high-speed differential output signals of the MPC92433 are incompatible to single-ended LVCMOS signals. In order to use the synthesizer in LVCMOS clock signal environments, the dual-channel translator device MC100ES60T23 provides the necessary level conversion. The MC100ES60T23 has been specifically designed to interface with the MPC92433 and supports clock frequencies up to 300 MHz.

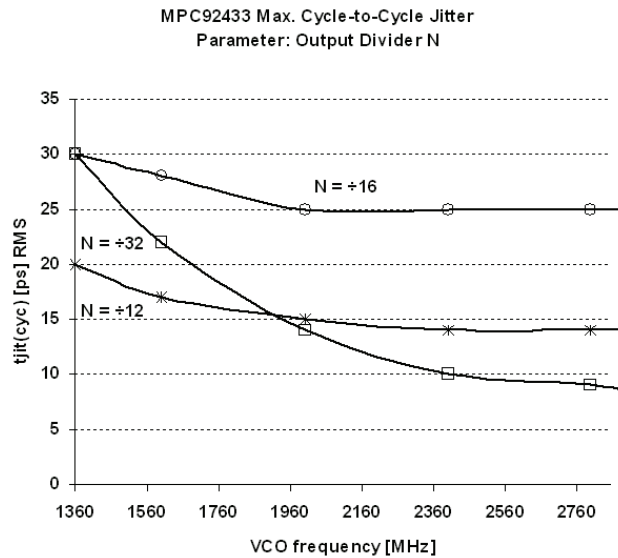

Figure 8. MPC92433 Cycle-to-Cycle Jitter

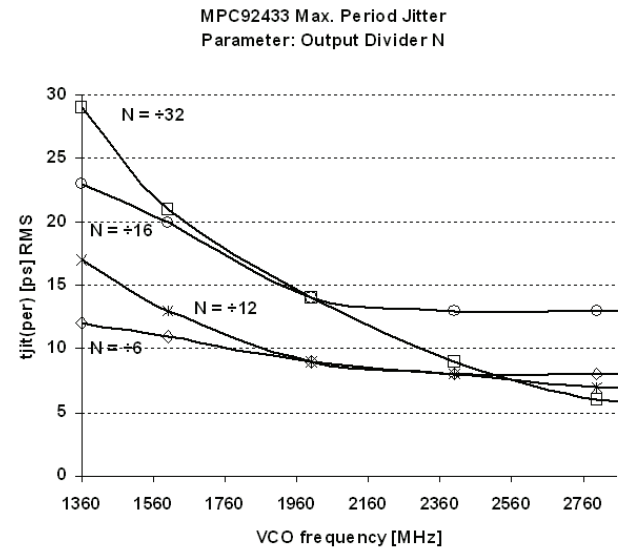

Figure 9. MPC92433 Period Jitter

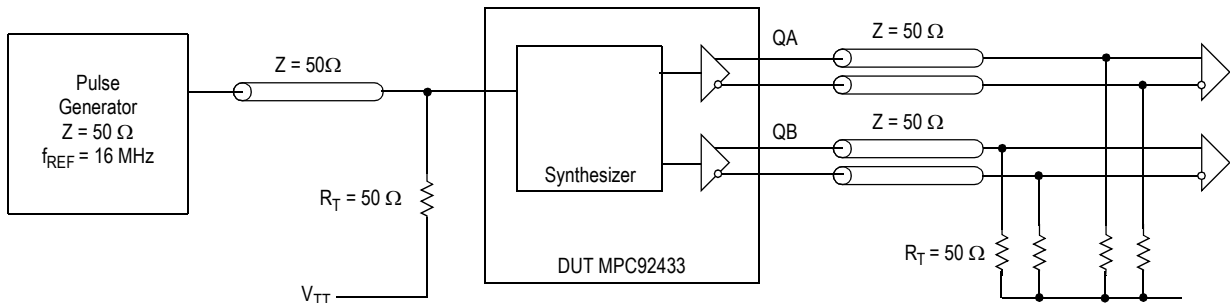

Figure 10. MPC92433 AC Test Reference

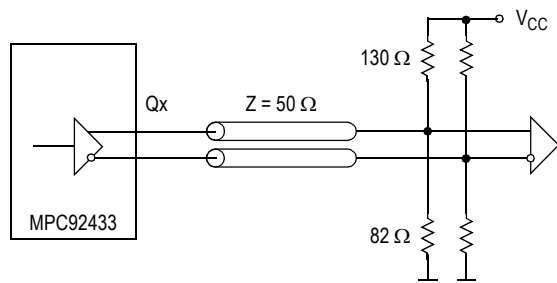

Figure 11. Thevenin Termination

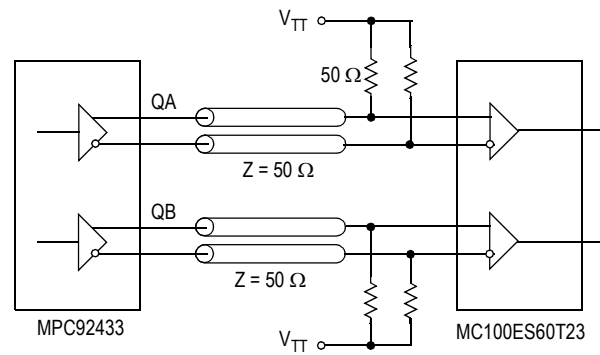

Figure 13. Interfacing with LVCMOS Logic for $f < 300$ MHz

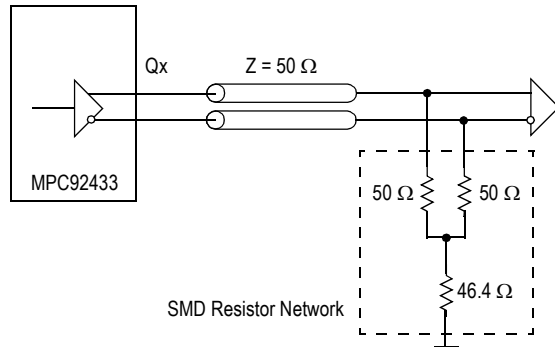
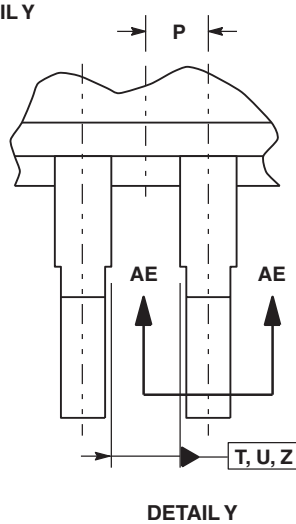
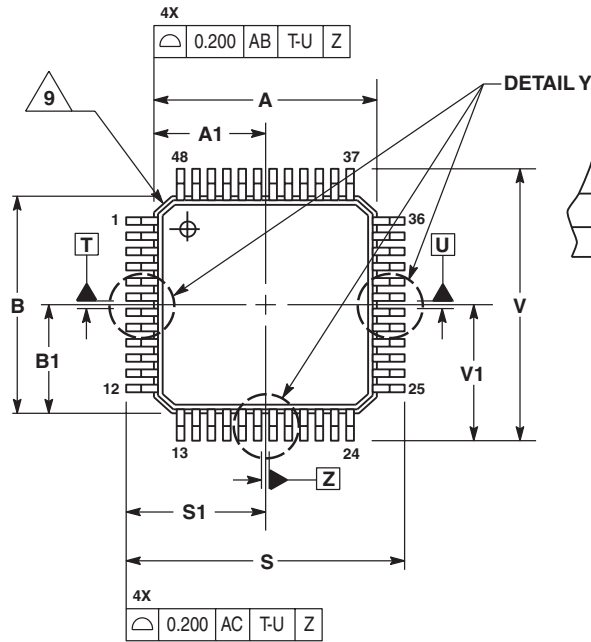

Figure 12. Resistor Network Termination

OUTLINE DIMENSIONS



- NOTES:
1. DIMENSIONING AND TOLERANCING PER ASME Y14.5m, 1994.
 2. CONTROLLING DIMENSION: MILLIMETER.
 3. DATUM PLAN AB IS LOCATED AT BOTTOM OF LEAD AND IS COINCIDENT WITH THE LEAD WHERE THE LEAD EXITS THE PLASTIC BODY AT THE BOTTOM OF THE PARTING LINE.
 4. DATUMS T, U, AND Z TO BE DETERMINED AT DATUM PLANE AB.
 5. DIMENSIONS S AND V TO BE DETERMINED AT SEATING PLANE AC.
 6. DIMENSIONS A AND B DO NOT INCLUDE MOLD PROTRUSION. ALLOWABLE PROTRUSION IS 0.250 PER SIDE. DIMENSIONS A AND B DO INCLUDE MOLD MISMATCH AND ARE DETERMINED AT DATUM PLANE AB.
 7. DIMENSION D DOES NOT INCLUDE DAMBAR PROTRUSION. DAMBAR PROTRUSION SHALL NOT CAUSE THE D DIMENSION TO EXCEED 0.350.
 8. MINIMUM SOLDER PLATE THICKNESS SHALL BE 0.0076.
 9. EXACT SHAPE OF EACH CORNER IS OPTIONAL.

MILLIMETERS		
DIM	MIN	MAX
A	7.000	BSC
A1	3.500	BSC
B	7.000	BSC
B1	3.500	BSC
C	1.400	1.600
D	0.170	0.270
E	1.350	1.450
F	0.170	0.230
G	0.500 BSC	
H	0.050	0.150
J	0.090	0.200
K	0.500	0.700
L	0'	7'
M	12' REF	
N	0.090	0.160
P	0.250 BSC	
R	0.150	0.250
S	9.000 BSC	
S1	4.500	BSC
V	9.000 BSC	
V1	4.500	BSC
W	0.200 REF	
AA	1.000 REF	

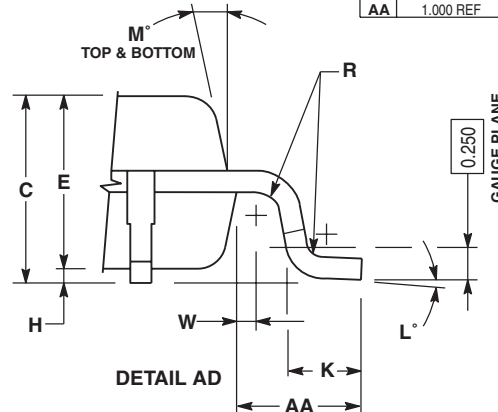
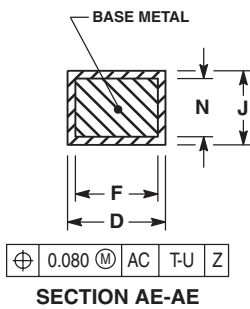
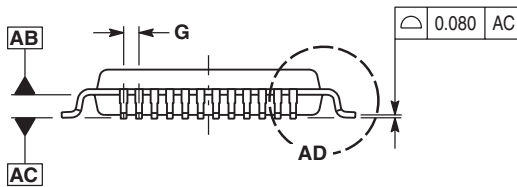

**FA SUFFIX
 48-LEAD LQFP PACKAGE
 CASE 932-03
 ISSUE F**

How to Reach Us:

Home Page:

www.freescale.com

E-mail:

support@freescale.com

USA/Europe or Locations Not Listed:

Freescale Semiconductor
Technical Information Center, CH370
1300 N. Alma School Road
Chandler, Arizona 85224
+1-800-521-6274 or +1-480-768-2130
support@freescale.com

Europe, Middle East, and Africa:

Freescale Halbleiter Deutschland GmbH
Technical Information Center
Schatzbogen 7
81829 Muenchen, Germany
+44 1296 380 456 (English)
+46 8 52200080 (English)
+49 89 92103 559 (German)
+33 1 69 35 48 48 (French)
support@freescale.com

Japan:

Freescale Semiconductor Japan Ltd.
Headquarters
ARCO Tower 15F
1-8-1, Shimo-Meguro, Meguro-ku,
Tokyo 153-0064
Japan
0120 191014 or +81 3 5437 9125
support.japan@freescale.com

Asia/Pacific:

Freescale Semiconductor Hong Kong Ltd.
Technical Information Center
2 Dai King Street
Tai Po Industrial Estate
Tai Po, N.T., Hong Kong
+800 2666 8080
support.asia@freescale.com

For Literature Requests Only:

Freescale Semiconductor Literature Distribution Center
P.O. Box 5405
Denver, Colorado 80217
1-800-441-2447 or 303-675-2140
Fax: 303-675-2150
LDCForFreescaleSemiconductor@hibbertgroup.com

Information in this document is provided solely to enable system and software implementers to use Freescale Semiconductor products. There are no express or implied copyright licenses granted hereunder to design or fabricate any integrated circuits or integrated circuits based on the information in this document.

Freescale Semiconductor reserves the right to make changes without further notice to any products herein. Freescale Semiconductor makes no warranty, representation or guarantee regarding the suitability of its products for any particular purpose, nor does Freescale Semiconductor assume any liability arising out of the application or use of any product or circuit, and specifically disclaims any and all liability, including without limitation consequential or incidental damages. "Typical" parameters that may be provided in Freescale Semiconductor data sheets and/or specifications can and do vary in different applications and actual performance may vary over time. All operating parameters, including "Typicals", must be validated for each customer application by customer's technical experts. Freescale Semiconductor does not convey any license under its patent rights nor the rights of others. Freescale Semiconductor products are not designed, intended, or authorized for use as components in systems intended for surgical implant into the body, or other applications intended to support or sustain life, or for any other application in which the failure of the Freescale Semiconductor product could create a situation where personal injury or death may occur. Should Buyer purchase or use Freescale Semiconductor products for any such unintended or unauthorized application, Buyer shall indemnify and hold Freescale Semiconductor and its officers, employees, subsidiaries, affiliates, and distributors harmless against all claims, costs, damages, and expenses, and reasonable attorney fees arising out of, directly or indirectly, any claim of personal injury or death associated with such unintended or unauthorized use, even if such claim alleges that Freescale Semiconductor was negligent regarding the design or manufacture of the part.

Freescale™ and the Freescale logo are trademarks of Freescale Semiconductor, Inc. All other product or service names are the property of their respective owners.

© Freescale Semiconductor, Inc. 2005. All rights reserved.

