

1 OMAP3515/03 Applications Processor

1.1 Features

- **OMAP3515/03 Applications Processor:**
 - **OMAP™ 3 Architecture**
 - **MPU Subsystem**
 - 600-MHz ARM Cortex™-A8 Core
 - NEON™ SIMD Coprocessor
 - **2D/3D Graphics Accelerator (OMAP3515 Device Only)**
 - Tile Based Architecture Delivering 10 MPoly/sec
 - Universal Scalable Shader Engine: Multi-threaded Engine Incorporating Pixel and Vertex Shader Functionality
 - Industry Standard API Support: OpenGL ES 1.1 and 2.0, OpenVG1.0 and Direct3D Mobile
 - Fine Grained Task Switching, Load Balancing, and Power Management
 - Programmable High Quality Image Anti-Aliasing
 - **Fully Software-Compatible With ARM9™**
- **ARM Cortex™-A8 Core**
 - **ARMv7 Architecture**
 - Trust Zone®
 - Thumb®-2
 - MMU Enhancements
 - **In-Order, Dual-Issue, Superscalar Microprocessor Core**
 - **NEON™ Multimedia Architecture**
 - **Over 2x Performance of ARMv6 SIMD**
 - **Supports Both Integer and Floating Point SIMD**
 - **Jazelle® RCT Execution Environment Architecture**
 - **Dynamic Branch Prediction with Branch Target Address Cache, Global History Buffer, and 8-Entry Return Stack**
 - **Embedded Trace Macrocell (ETM) Support for Non-Invasive Debug**
- **ARM Cortex™-A8 Memory Architecture:**
 - **16K-Byte Instruction Cache (4-Way Set-Associative)**
 - **16K-Byte Data Cache (4-Way Set-Associative)**
 - **256K-Byte L2 Cache**
- **Endianess: ARM Big Endian**
- **External Memory Interfaces:**
 - **SDRAM Controller (SDRC)**
 - 16, 32-bit Memory Controller With 2G-Byte Total Address Space
 - Interfaces to Low-Power Double Data Rate (LPDDR) SDRAM
 - SDRAM Memory Scheduler (SMS) and Rotation Engine
 - **General Purpose Memory Controller (GPMC)**
 - 16-bit Wide Multiplexed Address/Data Bus
 - Up to 8 Chip Select Pins With 129M-Byte Address Space per Chip Select Pin
 - Glueless Interface to NOR Flash, NAND Flash (With ECC Hamming Code Calculation), SRAM and Pseudo-SRAM
 - Flexible Asynchronous Protocol Control for Interface to Custom Logic (FPGA, CPLD, ASICs, etc.)
 - Nonmultiplexed Address/Data Mode (Limited 2K-Byte Address Space)
- **System Direct Memory Access (sDMA) Controller (32 Logical Channels With Configurable Priority)**
- **Camera Image Signal Processing (ISP)**
 - **CCD and CMOS Imager Interface**
 - **Memory Data Input**
 - **RAW Data Interface**
 - **BT.601/BT.656 Digital YCbCr 4:2:2 (8-/16-Bit) Interface**
 - **A-Law Compression and Decompression**
 - **Preview Engine for Real-Time Image Processing**
 - **Glueless Interface to Common Video Decoders**
 - **Histogram Module/Auto-Exposure, Auto-White Balance, and Auto-Focus Engine**
 - **Resize Engine**
 - Resize Images From 1/4x to 4x
 - Separate Horizontal/Vertical Control
- **Display Subsystem**
 - **Parallel Digital Output**
 - Up to 24-Bit RGB
 - HD Maximum Resolution

PRODUCT PREVIEW



Please be aware that an important notice concerning availability, standard warranty, and use in critical applications of Texas Instruments semiconductor products and disclaimers thereto appears at the end of this document.

is a trademark of ~ Texas Instruments.

All other trademarks are the property of their respective owners.

- Supports Up to 2 LCD Panels
- Support for Remote Frame Buffer Interface (RFB) LCD Panels
- 2 10-Bit Digital-to-Analog Converters (DACs) Supporting:
 - Composite NTSC/PAL Video
 - Luma/Chroma Separate Video (S-Video)
- Rotation 90-, 180-, and 270-degrees
- Resize Images From 1/4x to 8x
- Color Space Converter
- 8-bit Alpha Blending
- Serial Communication
 - 5 Multichannel Buffered Serial Ports (McBSPs)
 - 512 Byte Transmit/Receive Buffer (McBSP1/3/4/5)
 - 5K-Byte Transmit/Receive Buffer (McBSP2)
 - SIDETONE Core Support (McBSP2 and 3 Only) For Filter, Gain, and Mix Operations
 - Direct Interface to I2S and PCM Device and TDM Buses
 - 128 Channel Transmit/Receive Mode
 - Four Master/Slave Multichannel Serial Port Interface (McSPI) Ports
 - High-Speed/Full-Speed/Low-Speed USB OTG Controller (12-/8-Pin ULPI Interface)
 - High-Speed/Full-Speed/Low-Speed Multiport USB Host Controller
 - 12-/8-Pin ULPI Interface or 6-/4-/3-Pin Serial Interface
 - Supports Transceiverless Link Logic (TLL)
 - One HDQ/1-Wire Interface
 - Three UARTs (One with Infrared Data Association [IrDA] and Consumer Infrared [CIR] Modes)
 - Three Master/Slave High-Speed Inter-Integrated Circuit (I2C) Controllers
- Removable Media Interfaces:
 - Three Multimedia Card (MMC)/ Secure Digital (SD) With Secure Data I/O (SDIO)
- Comprehensive Power, Reset, and Clock Management
 - SmartReflex™ Technology
 - Dynamic Voltage and Frequency Scaling (DVFS)
- Test Interfaces
 - IEEE-1149.1 (JTAG) Boundary-Scan Compatible
 - Embedded Trace Macro Interface (ETM)
 - Serial Data Transport Interface (SDTI)
- 12 32-bit General Purpose Timers
- 2 32-bit Watchdog Timers
- 1 32-bit 32-kHz Sync Timer
- Up to 188 General-Purpose I/O (GPIO) Pins (Multiplexed With Other Device Functions)
- 65-nm CMOS Technology
- Package-On-Package (POP) Implementation for Memory Stacking (CBB Package Only)
- Packages:
 - 515-pin PBGA Package (CBB Suffix), .5mm Ball Pitch (Top), .4mm Ball Pitch (Bottom)
 - 423-pin PBGA Package (CUS Suffix), .65mm Ball Pitch
- 3.3-V and 1.8-V I/O, 0.8-V to 1.8-V Adaptive Core Voltage
- Applications:
 - TBD

1.2 Description

OMAP3515 and OMAP3503 high-performance, applications processors are based on the enhanced OMAP™ 3 architecture.

The OMAP™ 3 architecture is designed to provide best-in-class video, image, and graphics processing sufficient to support the following:

- Streaming video
- 2D/3D mobile gaming
- Video conferencing
- High-resolution still image
- Video capture in 2.5G wireless terminals, 3G wireless terminals, and rich multimedia-featured handsets, and high-performance personal digital assistants (PDAs).

The device supports high-level operating systems (OSs), such as:

- Windows CE
- Symbian OS
- Linux
- Palm OS

This OMAP device includes state-of-the-art power-management techniques required for high-performance mobile products.

The following subsystems are part of the device:

- Microprocessor unit (MPU) subsystem based on the ARM Cortex™-A8 microprocessor
- SGX530 subsystem for 2D and 3D graphics acceleration to support display and gaming effects (3515only)
- Camera image signal processor (ISP) that supports multiple formats and interfacing options connected to a wide variety of image sensors
- Display subsystem with a wide variety of features for multiple concurrent image manipulation, and a programmable interface supporting a wide variety of displays. The display subsystem also supports NTSC/PAL video out.
- Level 3 (L3) and level 4 (L4) interconnects that provide high-bandwidth data transfers for multiple initiators to the internal and external memory controllers and to on-chip peripherals

The device also offers:

- A comprehensive power and clock-management scheme that enables high-performance, low-power operation, and ultralow-power standby features. The device also supports SmartReflex™ adaptive voltage control. This power management technique for automatic control of the operating voltage of a module reduces the active power consumption.
- Memory stacking feature using the package-on-package (POP) implementation (CBB package only)

OMAP3515/03 devices are available in a 515-pin PBGA package (CBB suffix) and a 423-pin PBGA package (CUS suffix). Some features of the CBB package are not available in the CUS package.

[Table 1-1](#) lists the differences between the CBB and CUS packages.

Table 1-1. Differences Between CBB and CUS Packages

Feature	CBB Package	CUS Package
Pin Assignments	For CBB package pin assignments, see Table 2-1, Ball Characteristics (CBB Package) .	Pin assignments are different from the CUS package. For CUS package pin assignments, see Table 2-2, Ball Characteristics (CUS Package) .
Package-On-Package (POP) Interface	POP interface supported.	POP interface not available.
GPMC	Eight chip select pins available.	Chip select pins gpmc_ncs1 and gpmc_ncs2 are not available.
	Four wait pins available.	Wait pins gpmc_wait1 and gpmc_wait2 are not available.
UART2	The following signals are available on two pins (double muxed): uart2_cts (AF6/AB26), uart2_rts (AE6/AB25), uart2_tx (AF5/AA25), and uart2_rx (AE5/AD25).	The following signals are available on one pin only: uart2_cts (V6), uart2_rts (V5), uart2_tx (W4), and uart2_rx (V4).
McBSP3	The following signals are available on three pins (triple muxed): mcbbsp3_dx (AF6/AB26/V21), mcbbsp3_dr (AE6/AB25/U21), mcbbsp3_clkx (AF5/AA25/W21), and mcbbsp3_fsx (AE5/AD25/K26).	The following signals are available on two pins only (double muxed): mcbbsp3_dx (V6/W18), mcbbsp3_dr (V5/Y18), mcbbsp3_clkx (W4/V18), and mcbbsp3_fsx (V4/AA19).
GP Timer	The following signals are available on three pins (triple muxed): gpt8_pwm_evt (N8/AD25/V3), gpt9_pwm_evt (T8/AB26/Y2), gpt10_pwm_evt (R8/AB25/Y3), and gpt11_pwm_evt (P8/AA25/Y4).	The following signals are available on two pins only (double muxed): gpt8_pwm_evt (G4/M4), gpt9_pwm_evt (F4/N4), gpt10_pwm_evt (G5/N3), and gpt11_pwm_evt (F3/M5).
McBSP4	The following signals are available on two pins (double muxed): mcbbsp4_clkx (T8/AE1), mcbbsp4_dr (R8/AD1), mcbbsp4_dx (P8/AD2), and mcbbsp4_fsx (N8/AC1).	The following signals are available on one pin only: mcbbsp4_clkx (F4), mcbbsp4_dr (G5), mcbbsp4_dx (F3), and mcbbsp4_fsx (G4).
HSUSB3_TLL	Supported.	Not Supported.
MM_FSUSB3	Supported.	Not Supported.
McSPI1	Four chip select pins are available.	Chip select pins mcspi1_cs1 and mcspi1_cs2 are not available.
MMC3	The following signals are available on two pins (double muxed): mmc3_cmd (AC3/AE10) and mmc3_clk (AB1/AF10).	The following signals are available on one pin only: mmc3_cmd (AD3) and mmc3_clk (AC1).
GPIO	A maximum of 188 GPIO pins are supported.	A maximum of 170 GPIO pins are supported. The following GPIO pins are not available: gpio_112, gpio_113, gpio_114, gpio_115, gpio_52, gpio_53, gpio_63, gpio_64, gpio_144, gpio_145, gpio_146, gpio_147, gpio_152, gpio_153, gpio_154, gpio_155, gpio_175, and gpio_176. Pin muxing restricts the total number of GPIO pins available at one time. For more details, see Table 2-4, Multiplexing Characteristics (CUS Pkg.) .
PLL	The adpll2d_dithering_en2 pin is supported.	The adpll2d_dithering_en2 pin is not supported.

This OMAP3515/03 Applications Processor data manual presents the electrical and mechanical specifications for the OMAP3515/03 Applications Processor. It consists of the following sections:

- A description of the OMAP3515/03 terminals: assignment, electrical characteristics, multiplexing, and functional description ([Section 2](#))
- A presentation of the electrical characteristics requirements: power domains, operating conditions, power consumption, and dc characteristics ([Section 3](#))
- The clock specifications: input and output clocks, DPLL and DLL ([Section 4](#))
- The video DAC specification ([Section 5](#))
- The timing requirements and switching characteristics (ac timings) of the interfaces ([Section 6](#))
- A description of thermal characteristics, device nomenclature, and mechanical data about the available packaging ([Section 7](#))

1.3 Functional Block Diagram

Figure 1-1 shows the functional block diagram of the OMAP3515/03 Applications Processor.

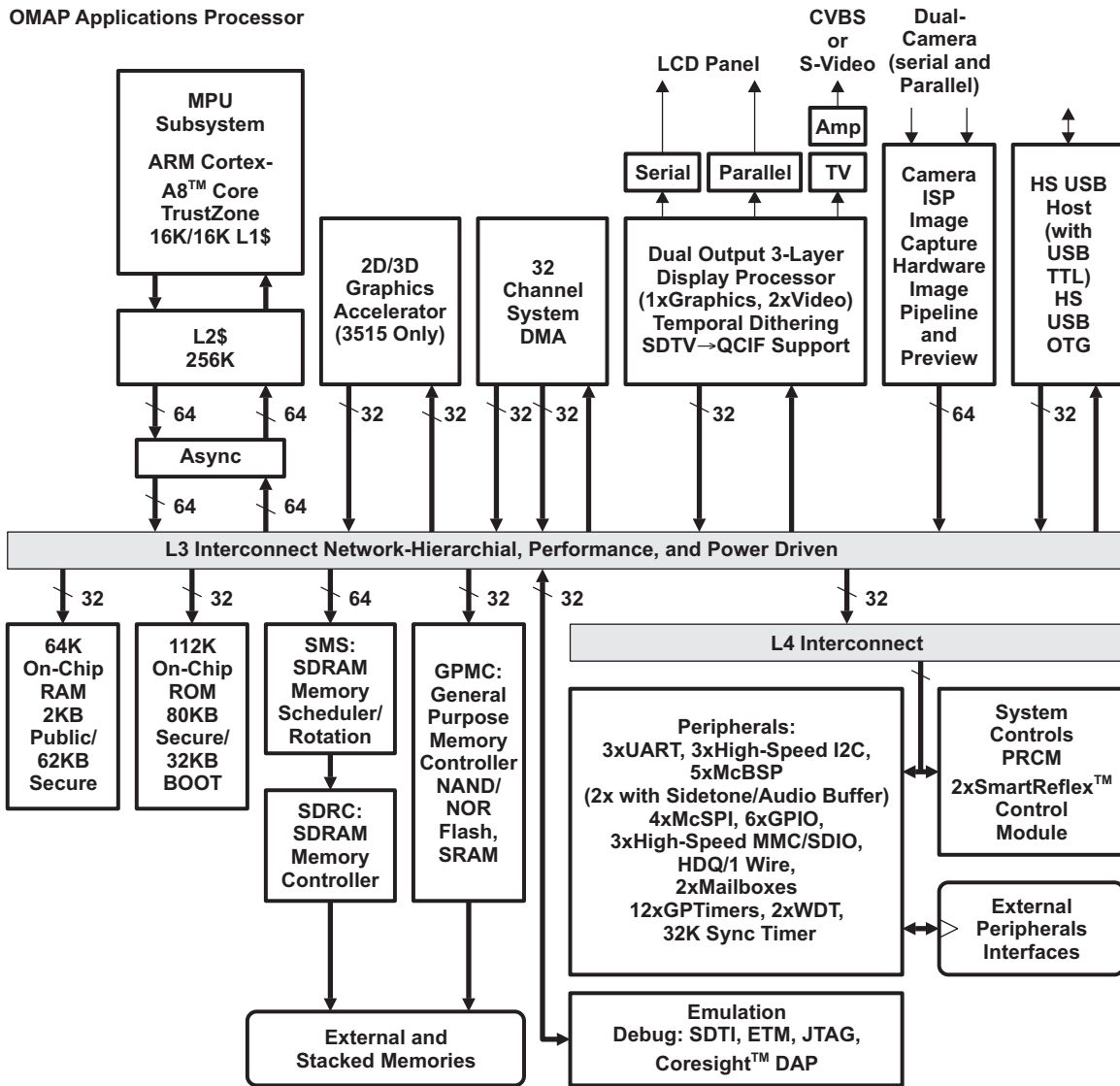

Figure 1-1. OMAP3515/03 Functional Block Diagram

PRODUCT PREVIEW

Contents

1	OMAP3515/03 Applications Processor	1	5	VIDEO DAC SPECIFICATIONS	122
1.1	Features	1	5.1	Interface Description	122
1.2	Description	3	5.2	Electrical Specifications Over Recommended Operating Conditions	124
1.3	Functional Block Diagram	5	5.3	Analog Supply (vdda_dac) Noise Requirements ..	126
2	TERMINAL DESCRIPTION	7	5.4	External Component Value Choice	127
2.1	Terminal Assignment	7	6	TIMING REQUIREMENTS AND SWITCHING CHARACTERISTICS	128
2.2	Ball Characteristics	10	6.1	Timing Test Conditions	128
2.3	Multiplexing Characteristics	57	6.2	Interface Clock Specifications	128
2.4	Signal Description	72	6.3	Timing Parameters.....	129
3	ELECTRICAL CHARACTERISTICS	96	6.4	External Memory Interfaces.....	130
3.1	Power Domains	96	6.5	Video Interfaces.....	152
3.2	Absolute Maximum Ratings	98	6.6	Serial Communications Interfaces	169
3.3	Recommended Operating Conditions	100	6.7	Removable Media Interfaces	201
3.4	DC Electrical Characteristics.....	101	6.8	Test Interfaces	216
3.5	Core Voltage Decoupling	103	7	PACKAGE CHARACTERISTICS	222
3.6	Power-up and Power-down	105	7.1	Package Thermal Resistance.....	222
4	CLOCK SPECIFICATIONS	108	7.2	Device Support.....	222
4.1	Input Clock Specifications	109			
4.2	Output Clock Specifications.....	114			
4.3	DPLL and DLL Specifications.....	116			

2 TERMINAL DESCRIPTION

2.1 Terminal Assignment

Figure 2-1, Figure 2-2, and Figure 2-3 show the ball locations for the 515- and 423- ball plastic ball grid array (PBGA) packages. Table 2-1 through Table 2-24 indicate the signal names and ball grid numbers for both packages.

Note: There are no balls present on the top of the 423-ball PBGA package.

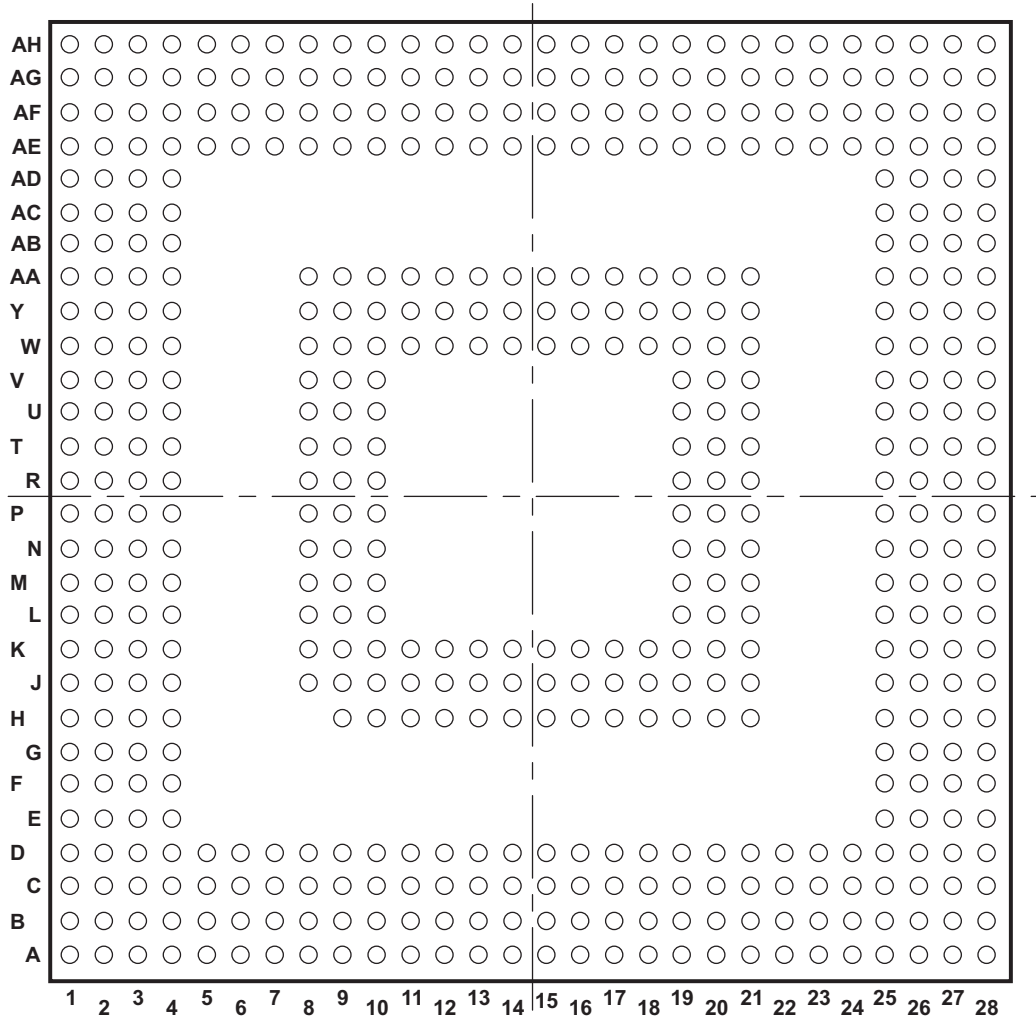

030-001

Figure 2-1. OMAP3515/03 Applications Processor CBB S-PBGA-N515 Package (Bottom View)

PRODUCT PREVIEW

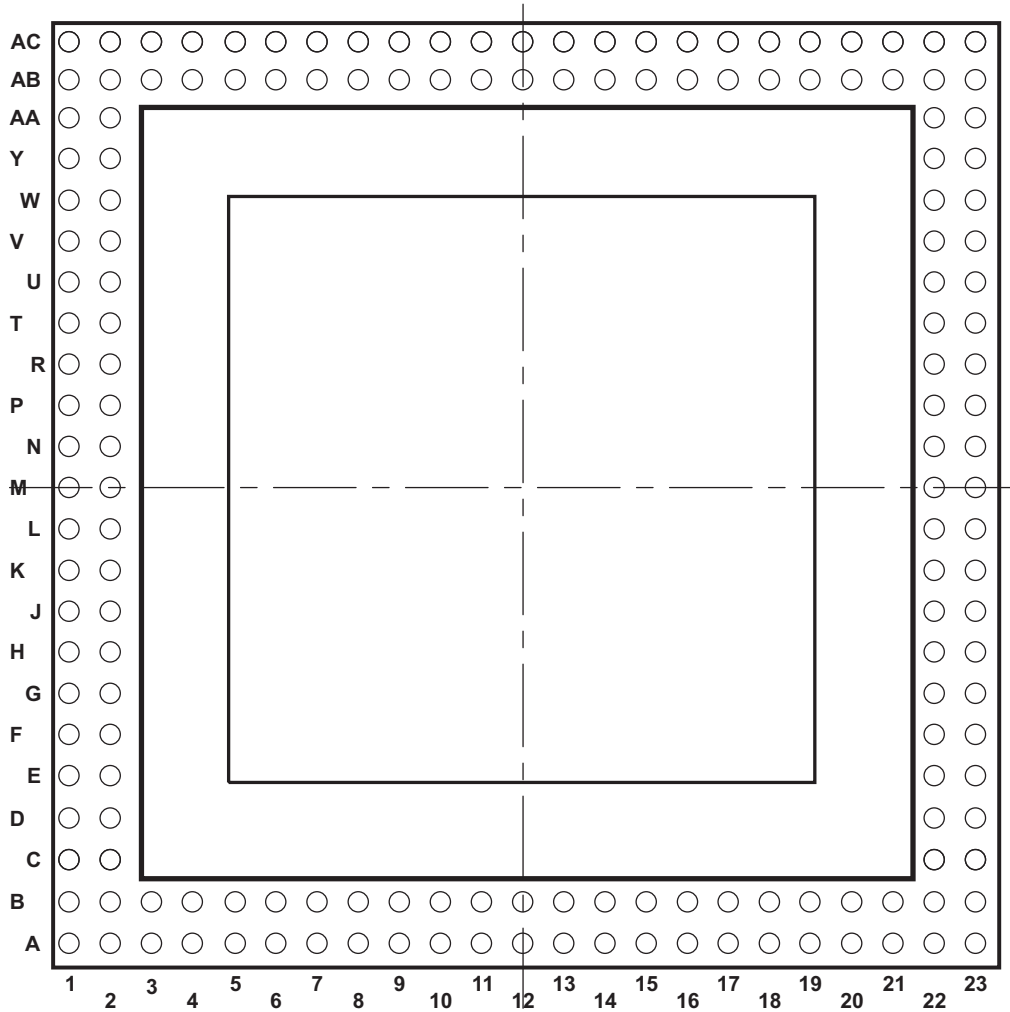

030-002

Balls A1, A2, A22, A23, AB1, AB2, AB22, AB23, AC1, AC2, AC22, AC23, B1, B2, B22, and B23 are unused.

Figure 2-2. OMAP3515/03 Applications Processor CBB S-PBGA-N515 Package (Top View)

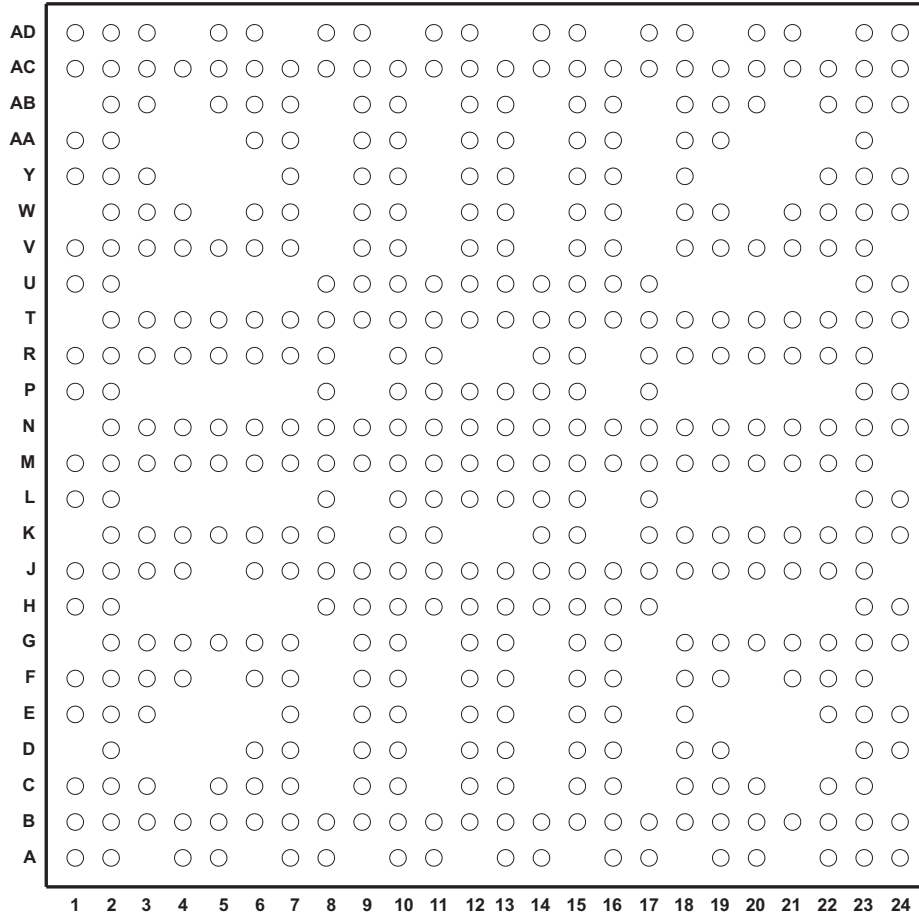

Figure 2-3. OMAP3515/03 Applications Processor CUS-PBGA-N423 Package (Bottom View)

PRODUCT PREVIEW

2.2 Ball Characteristics

Table 2-1 and Table 2-2 describe the terminal characteristics and the signals multiplexed on each pin for the CBB and CUS package, respectively. The following list describes the table column headers:

1. **BALL BOTTOM:** Ball number(s) on the bottom side associated with each signal(s) on the bottom.
2. **BALL TOP:** Ball number(s) on the top side associated with each signal(s) on the top.
3. **PIN NAME:** Names of signals multiplexed on each ball (also notice that the name of the pin is the signal name in mode 0).

Note: Table 2-1 and Table 2-2 do not take into account subsystem pin multiplexing options. Subsystem pin multiplexing options are described in Section 2.4, *Signal Descriptions*.

4. **MODE:** Multiplexing mode number.
 - a. Mode 0 is the primary mode; this means that when mode 0 is set, the function mapped on the pin corresponds to the name of the pin. There is always a function mapped on the primary mode. Notice that primary mode is not necessarily the default mode.

Note: The default mode is the mode which is automatically configured on release of the internal GLOBAL_PWRON reset; also see the RESET REL. MODE column.
 - b. Modes 1 to 7 are possible modes for alternate functions. On each pin, some modes are effectively used for alternate functions, while some modes are not used and do not correspond to a functional configuration.
5. **TYPE:** Signal direction
 - I = Input
 - O = Output
 - I/O = Input/Output
 - D = Open drain
 - DS = Differential
 - A = Analog

Note: In the safe_mode, the buffer is configured in high-impedance.

6. **BALL RESET STATE:** The state of the terminal at reset (power up).
 - 0: The buffer drives V_{OL} (pulldown/pullup resistor not activated)
0(PD): The buffer drives V_{OL} with an active pulldown resistor.
 - 1: The buffer drives V_{OH} (pulldown/pullup resistor not activated)
1(PU): The buffer drives V_{OH} with an active pullup resistor.
 - Z: High-impedance
 - L: High-impedance with an active pulldown resistor
 - H : High-impedance with an active pullup resistor
7. **BALL RESET REL. STATE:** The state of the terminal at reset release.
 - 0: The buffer drives V_{OL} (pulldown/pullup resistor not activated)
0(PD): The buffer drives V_{OL} with an active pulldown resistor.
 - 1: The buffer drives V_{OH} (pulldown/pullup resistor not activated)
1(PU): The buffer drives V_{OH} with an active pullup resistor.
 - Z: High-impedance
 - L: High-impedance with an active pulldown resistor
 - H : High-impedance with an active pullup resistor
8. **RESET REL. MODE:** This mode is automatically configured on release of the internal GLOBAL_PWRON reset.
9. **POWER:** The voltage supply that powers the terminal's I/O buffers.
10. **HYS:** Indicates if the input buffer is with hysteresis.
11. **BUFFER STRENGTH:** Drive strength of the associated output buffer.
12. **PULL U/D - TYPE:** Denotes the presence of an internal pullup or pulldown resistor. Pullup and pulldown resistors can be enabled or disabled via software.

Note: The pullup/pulldown drive strength is equal to 100 μ A except for CBB balls P27, P26, R27, and R25 and CUB balls N22, N21, N20, and P24, which the pulldown drive strength is equal to 1.8 k Ω .

13. IO CELL: IO cell information.

Note: Configuring two pins to the same input signal is not supported as it can yield unexpected results. This can be easily prevented with the proper software configuration.

Table 2-1. Ball Characteristics (CBB Pkg.)⁽¹⁾

BALL BOTTOM [1]	BALL TOP [2]	PIN NAME [3]	MODE [4]	TYPE [5]	BALL RESET STATE [6]	BALL RESET REL. STATE [7]	RESET REL. MODE [8]	POWER [9]	HYS [10]	BUFFER STRENGTH (mA) [11]	PULL U/D TYPE [12]	IO CELL [13]
D6	J2	sdrc_d0	0	IO	L	Z	0	VDDSD_MEM	Yes	4	PU/PD	LVCNOS
C6	J1	sdrc_d1	0	IO	L	Z	0	VDDSD_MEM	Yes	4	PU/PD	LVCNOS
B6	G2	sdrc_d2	0	IO	L	Z	0	VDDSD_MEM	Yes	4	PU/PD	LVCNOS
C8	G1	sdrc_d3	0	IO	L	Z	0	VDDSD_MEM	Yes	4	PU/PD	LVCNOS
C9	F2	sdrc_d4	0	IO	L	Z	0	VDDSD_MEM	Yes	4	PU/PD	LVCNOS
A7	F1	sdrc_d5	0	IO	L	Z	0	VDDSD_MEM	Yes	4	PU/PD	LVCNOS
B9	D2	sdrc_d6	0	IO	L	Z	0	VDDSD_MEM	Yes	4	PU/PD	LVCNOS
A9	D1	sdrc_d7	0	IO	L	Z	0	VDDSD_MEM	Yes	4	PU/PD	LVCNOS
C14	B13	sdrc_d8	0	IO	L	Z	0	VDDSD_MEM	Yes	4	PU/PD	LVCNOS
B14	A13	sdrc_d9	0	IO	L	Z	0	VDDSD_MEM	Yes	4	PU/PD	LVCNOS
C15	B14	sdrc_d10	0	IO	L	Z	0	VDDSD_MEM	Yes	4	PU/PD	LVCNOS
B16	A14	sdrc_d11	0	IO	L	Z	0	VDDSD_MEM	Yes	4	PU/PD	LVCNOS
D17	B16	sdrc_d12	0	IO	L	Z	0	VDDSD_MEM	Yes	4	PU/PD	LVCNOS
C17	A16	sdrc_d13	0	IO	L	Z	0	VDDSD_MEM	Yes	4	PU/PD	LVCNOS
B17	B19	sdrc_d14	0	IO	L	Z	0	VDDSD_MEM	Yes	4	PU/PD	LVCNOS
D18	A19	sdrc_d15	0	IO	L	Z	0	VDDSD_MEM	Yes	4	PU/PD	LVCNOS
D11	B3	sdrc_d16	0	IO	L	Z	0	VDDSD_MEM	Yes	4	PU/PD	LVCNOS
B10	A3	sdrc_d17	0	IO	L	Z	0	VDDSD_MEM	Yes	4	PU/PD	LVCNOS
C11	B5	sdrc_d18	0	IO	L	Z	0	VDDSD_MEM	Yes	4	PU/PD	LVCNOS
D12	A5	sdrc_d19	0	IO	L	Z	0	VDDSD_MEM	Yes	4	PU/PD	LVCNOS
C12	B8	sdrc_d20	0	IO	L	Z	0	VDDSD_MEM	Yes	4	PU/PD	LVCNOS
A11	A8	sdrc_d21	0	IO	L	Z	0	VDDSD_MEM	Yes	4	PU/PD	LVCNOS

PRODUCT PREVIEW

Table 2-1. Ball Characteristics (CBB Pkg.)⁽¹⁾ (continued)

BALL BOTTOM [1]	BALL TOP [2]	PIN NAME [3]	MODE [4]	TYPE [5]	BALL RESET STATE [6]	BALL RESET REL. STATE [7]	RESET REL. MODE [8]	POWER [9]	HYS [10]	BUFFER STRENGTH (mA) [11]	PULL U/D TYPE [12]	IO CELL [13]
B13	B9	sdr_c_d22	0	IO	L	Z	0	VDDSD_MEM	Yes	4	PU/PD	LVCNOS
D14	A9	sdr_c_d23	0	IO	L	Z	0	VDDSD_MEM	Yes	4	PU/PD	LVCNOS
C18	B21	sdr_c_d24	0	IO	L	Z	0	VDDSD_MEM	Yes	4	PU/PD	LVCNOS
A19	A21	sdr_c_d25	0	IO	L	Z	0	VDDSD_MEM	Yes	4	PU/PD	LVCNOS
B19	D22	sdr_c_d26	0	IO	L	Z	0	VDDSD_MEM	Yes	4	PU/PD	LVCNOS
B20	D23	sdr_c_d27	0	IO	L	Z	0	VDDSD_MEM	Yes	4	PU/PD	LVCNOS
D20	E22	sdr_c_d28	0	IO	L	Z	0	VDDSD_MEM	Yes	4	PU/PD	LVCNOS
A21	E23	sdr_c_d29	0	IO	L	Z	0	VDDSD_MEM	Yes	4	PU/PD	LVCNOS
B21	G22	sdr_c_d30	0	IO	L	Z	0	VDDSD_MEM	Yes	4	PU/PD	LVCNOS
C21	G23	sdr_c_d31	0	IO	L	Z	0	VDDSD_MEM	Yes	4	PU/PD	LVCNOS
H9	AB21	sdr_c_ba0	0	O	0	0	0	VDDSD_MEM	No	4	NA	LVCNOS
H10	AC21	sdr_c_ba1	0	O	0	0	0	VDDSD_MEM	No	4	NA	LVCNOS
A4	N22	sdr_c_a0	0	O	0	0	0	VDDSD_MEM	No	4	NA	LVCNOS
B4	N23	sdr_c_a1	0	O	0	0	0	VDDSD_MEM	No	4	NA	LVCNOS
B3	P22	sdr_c_a2	0	O	0	0	0	VDDSD_MEM	No	4	NA	LVCNOS
C5	P23	sdr_c_a3	0	O	0	0	0	VDDSD_MEM	No	4	NA	LVCNOS
C4	R22	sdr_c_a4	0	O	0	0	0	VDDSD_MEM	No	4	NA	LVCNOS
D5	R23	sdr_c_a5	0	O	0	0	0	VDDSD_MEM	No	4	NA	LVCNOS
C3	T22	sdr_c_a6	0	O	0	0	0	VDDSD_MEM	No	4	NA	LVCNOS
C2	T23	sdr_c_a7	0	O	0	0	0	VDDSD_MEM	No	4	NA	LVCNOS
C1	U22	sdr_c_a8	0	O	0	0	0	VDDSD_MEM	No	4	NA	LVCNOS
D4	U23	sdr_c_a9	0	O	0	0	0	VDDSD_MEM	No	4	NA	LVCNOS
D3	V22	sdr_c_a10	0	O	0	0	0	VDDSD_MEM	No	4	NA	LVCNOS
D2	V23	sdr_c_a11	0	O	0	0	0	VDDSD_MEM	No	4	NA	LVCNOS
D1	W22	sdr_c_a12	0	O	0	0	0	VDDSD_MEM	No	4	NA	LVCNOS
E2	W23	sdr_c_a13	0	O	0	0	0	VDDSD_MEM	No	4	NA	LVCNOS
E1	Y22	sdr_c_a14	0	O	0	0	0	VDDSD_MEM	No	4	NA	LVCNOS
H11	M22	sdr_c_ncs0	0	O	1	1	0	VDDSD_MEM	No	4	NA	LVCNOS
H12	M23	sdr_c_ncs1	0	O	1	1	0	VDDSD_MEM	No	4	NA	LVCNOS
A13	A11	sdr_c_clk	0	IO	L	0	0	VDDSD_MEM	Yes	4	PU/PD	LVCNOS
A14	B11	sdr_c_nclk	0	O	1	1	0	VDDSD_MEM	No	4	NA	LVCNOS
H16	J22	sdr_c_cke0	0	O	H	1	7	VDDSD_MEM	Yes	4	PU/PD	LVCNOS
		safe_mode	7									
H17	J23	sdr_c_cke1	0	O	H	1	7	VDDSD_MEM	Yes	4	PU/PD	LVCNOS
		safe_mode	7									
H14	L23	sdr_c_nras	0	O	1	1	0	VDDSD_MEM	No	4	NA	LVCNOS
H13	L22	sdr_c_ncas	0	O	1	1	0	VDDSD_MEM	No	4	NA	LVCNOS

PRODUCT PREVIEW

Table 2-1. Ball Characteristics (CBB Pkg.)⁽¹⁾ (continued)

BALL BOTTOM [1]	BALL TOP [2]	PIN NAME [3]	MODE [4]	TYPE [5]	BALL RESET STATE [6]	BALL RESET REL. STATE [7]	RESET REL. MODE [8]	POWER [9]	HYS [10]	BUFFER STRENGTH (mA) [11]	PULL U/D TYPE [12]	IO CELL [13]
H15	K23	sdrc_nwe	0	O	1	1	0	VDDDS_MEM	No	4	NA	LVC MOS
B7	C1	sdrc_dm0	0	O	0	0	0	VDDDS_MEM	No	4	NA	LVC MOS
A16	A17	sdrc_dm1	0	O	0	0	0	VDDDS_MEM	No	4	NA	LVC MOS
B11	A6	sdrc_dm2	0	O	0	0	0	VDDDS_MEM	No	4	NA	LVC MOS
C20	A20	sdrc_dm3	0	O	0	0	0	VDDDS_MEM	No	4	NA	LVC MOS
A6	C2	sdrc_dqs0	0	IO	L	Z	0	VDDDS_MEM	Yes	4	PU/PD	LVC MOS
A17	B17	sdrc_dqs1	0	IO	L	Z	0	VDDDS_MEM	Yes	4	PU/PD	LVC MOS
A10	B6	sdrc_dqs2	0	IO	L	Z	0	VDDDS_MEM	Yes	4	PU/PD	LVC MOS
A20	B20	sdrc_dqs3	0	IO	L	Z	0	VDDDS_MEM	Yes	4	PU/PD	LVC MOS
N4	AC15	gpmc_a1	0	O	L	L	7	VDDDS_MEM	Yes	4	PU/PD	LVC MOS
		gpio_34	4	IO								
		safe_mode	7									
M4	AB15	gpmc_a2	0	O	L	L	7	VDDDS_MEM	Yes	4	PU/PD	LVC MOS
		gpio_35	4	IO								
		safe_mode	7									
L4	AC16	gpmc_a3	0	O	L	L	7	VDDDS_MEM	Yes	4	PU/PD	LVC MOS
		gpio_36	4	IO								
		safe_mode	7									
K4	AB16	gpmc_a4	0	O	L	L	7	VDDDS_MEM	Yes	4	PU/PD	LVC MOS
		gpio_37	4	IO								
		safe_mode	7									
T3	AC17	gpmc_a5	0	O	L	L	7	VDDDS_MEM	Yes	4	PU/PD	LVC MOS
		gpio_38	4	IO								
		safe_mode	7									
R3	AB17	gpmc_a6	0	O	H	H	7	VDDDS_MEM	Yes	4	PU/PD	LVC MOS
		gpio_39	4	IO								
		safe_mode	7									
N3	AC18	gpmc_a7	0	O	H	H	7	VDDDS_MEM	Yes	4	PU/PD	LVC MOS
		gpio_40	4	IO								
		safe_mode	7									
M3	AB18	gpmc_a8	0	O	H	H	7	VDDDS_MEM	Yes	4	PU/PD	LVC MOS
		gpio_41	4	IO								
		safe_mode	7									
L3	AC19	gpmc_a9	0	O	H	H	7	VDDDS_MEM	Yes	4	PU/PD	LVC MOS
		sys_ndmareq2	1	I								
		gpio_42	4	IO								
		safe_mode	7									
K3	AB19	gpmc_a10	0	O	H	H	7	VDDDS_MEM	Yes	4	PU/PD	LVC MOS
		sys_ndmareq3	1	I								
		gpio_43	4	IO								

PRODUCT PREVIEW

Table 2-1. Ball Characteristics (CBB Pkg.)⁽¹⁾ (continued)

BALL BOTTOM [1]	BALL TOP [2]	PIN NAME [3]	MODE [4]	TYPE [5]	BALL RESET STATE [6]	BALL RESET REL. STATE [7]	RESET REL. MODE [8]	POWER [9]	HYS [10]	BUFFER STRENGTH (mA) [11]	PULL U/D TYPE [12]	IO CELL [13]
		safe_mode	7									
K1	M2	gpmc_d0	0	IO	H	H	0	VDDS_MEM	Yes	4	PU/PD	LVC MOS
L1	M1	gpmc_d1	0	IO	H	H	0	VDDS_MEM	Yes	4	PU/PD	LVC MOS
L2	N2	gpmc_d2	0	IO	H	H	0	VDDS_MEM	Yes	4	PU/PD	LVC MOS
P2	N1	gpmc_d3	0	IO	H	H	0	VDDS_MEM	Yes	4	PU/PD	LVC MOS
T1	R2	gpmc_d4	0	IO	H	H	0	VDDS_MEM	Yes	4	PU/PD	LVC MOS
V1	R1	gpmc_d5	0	IO	H	H	0	VDDS_MEM	Yes	4	PU/PD	LVC MOS
V2	T2	gpmc_d6	0	IO	H	H	0	VDDS_MEM	Yes	4	PU/PD	LVC MOS
W2	T1	gpmc_d7	0	IO	H	H	0	VDDS_MEM	Yes	4	PU/PD	LVC MOS
H2	AB3	gpmc_d8	0	IO	H	H	0	VDDS_MEM	Yes	4	PU/PD	LVC MOS
		gpio_44	4	IO								
		safe_mode	7									
K2	AC3	gpmc_d9	0	IO	H	H	0	VDDS_MEM	Yes	4	PU/PD	LVC MOS
		gpio_45	4	IO								
		safe_mode	7									
P1	AB4	gpmc_d10	0	IO	H	H	0	VDDS_MEM	Yes	4	PU/PD	LVC MOS
		gpio_46	4	IO								
		safe_mode	7									
R1	AC4	gpmc_d11	0	IO	H	H	0	VDDS_MEM	Yes	4	PU/PD	LVC MOS
		gpio_47	4	IO								
		safe_mode	7									
R2	AB6	gpmc_d12	0	IO	H	H	0	VDDS_MEM	Yes	4	PU/PD	LVC MOS
		gpio_48	4	IO								
		safe_mode	7									
T2	AC6	gpmc_d13	0	IO	H	H	0	VDDS_MEM	Yes	4	PU/PD	LVC MOS
		gpio_49	4	IO								
		safe_mode	7									
W1	AB7	gpmc_d14	0	IO	H	H	0	VDDS_MEM	Yes	4	PU/PD	LVC MOS
		gpio_50	4	IO								
		safe_mode	7									
Y1	AC7	gpmc_d15	0	IO	H	H	0	VDDS_MEM	Yes	4	PU/PD	LVC MOS
		gpio_51	4	IO								
		safe_mode	7									
G4	Y2	gpmc_ncs0	0	O	1	1	0	VDDS_MEM	No	4	NA	LVC MOS
H3	Y1	gpmc_ncs1	0	O	H	1	0	VDDS_MEM	Yes	4	PU/PD	LVC MOS
		gpio_52	4	IO								
		safe_mode	7									
V8	NA	gpmc_ncs2	0	O	H	H	7	VDDS_MEM	Yes	4	PU/PD	LVC MOS
		gpio_53	4	IO								

PRODUCT PREVIEW

Table 2-1. Ball Characteristics (CBB Pkg.)⁽¹⁾ (continued)

BALL BOTTOM [1]	BALL TOP [2]	PIN NAME [3]	MODE [4]	TYPE [5]	BALL RESET STATE [6]	BALL RESET REL. STATE [7]	RESET REL. MODE [8]	POWER [9]	HYS [10]	BUFFER STRENGTH (mA) [11]	PULL U/D TYPE [12]	IO CELL [13]
		safe_mode	7									
U8	NA	gpmc_ncs3	0	O	H	H	7	VDDDS_MEM	Yes	4	PU/PD	LVCMOS
		sys_ndmareq0	1	I								
		gpio_54	4	IO								
		safe_mode	7									
T8	NA	gpmc_ncs4	0	O	H	H	7	VDDDS_MEM	Yes	4	PU/PD	LVCMOS
		sys_ndmareq1	1	I								
		mcbasp4_clkx	2	IO								
		gpt9_pwm_evt	3	IO								
		gpio_55	4	IO								
		safe_mode	7									
R8	NA	gpmc_ncs5	0	O	H	H	7	VDDDS_MEM	Yes	4	PU/PD	LVCMOS
		sys_ndmareq2	1	I								
		mcbasp4_dr	2	I								
		gpt10_pwm_evt	3	IO								
		gpio_56	4	IO								
		safe_mode	7									
P8	NA	gpmc_ncs6	0	O	H	H	7	VDDDS_MEM	Yes	4	PU/PD	LVCMOS
		sys_ndmareq3	1	I								
		mcbasp4_dx	2	IO								
		gpt11_pwm_evt	3	IO								
		gpio_57	4	IO								
		safe_mode	7									
N8	NA	gpmc_ncs7	0	O	H	H	7	VDDDS_MEM	Yes	4	PU/PD	LVCMOS
		gpmc_io_dir	1	O								
		mcbasp4_fsx	2	IO								
		gpt8_pwm_evt	3	IO								
		gpio_58	4	IO								
		safe_mode	7									
T4	W2	gpmc_clk	0	O	L	0	0	VDDDS_MEM	Yes	4	PU/PD	LVCMOS
		gpio_59	4	IO								
		safe_mode	7									
F3	W1	gpmc_nadv_ale	0	O	0	0	0	VDDDS_MEM	No	4	NA	LVCMOS
G2	V2	gpmc_noe	0	O	1	1	0	VDDDS_MEM	No	4	NA	LVCMOS
F4	V1	gpmc_nwe	0	O	1	1	0	VDDDS_MEM	No	4	NA	LVCMOS
G3	AC12	gpmc_nbe0_cle	0	O	L	0	0	VDDDS_MEM	Yes	4	PU/PD	LVCMOS
		gpio_60	4	IO								

PRODUCT PREVIEW

Table 2-1. Ball Characteristics (CBB Pkg.)⁽¹⁾ (continued)

BALL BOTTOM [1]	BALL TOP [2]	PIN NAME [3]	MODE [4]	TYPE [5]	BALL RESET STATE [6]	BALL RESET REL. STATE [7]	RESET REL. MODE [8]	POWER [9]	HYS [10]	BUFFER STRENGTH (mA) [11]	PULL U/D TYPE [12]	IO CELL [13]
		safe_mode	7									
U3	NA	gpmc_nbe1	0	O	L	L	7	VDDDS_MEM	Yes	4	PU/PD	LVCMOS
		gpio_61	4	IO								
		safe_mode	7									
H1	AB10	gpmc_nwp	0	O	L	0	0	VDDDS_MEM	Yes	4	PU/PD	LVCMOS
		gpio_62	4	IO								
		safe_mode	7									
M8	AB12	gpmc_wait0	0	I	H	H	0	VDDDS_MEM	Yes	NA	PU/PD	LVCMOS
L8	AC10	gpmc_wait1	0	I	H	H	7	VDDDS_MEM	Yes	4	PU/PD	LVCMOS
		gpio_63	4	IO								
		safe_mode	7									
K8	NA	gpmc_wait2	0	I	H	H	7	VDDDS_MEM	Yes	4	PU/PD	LVCMOS
		gpio_64	4	IO								
		safe_mode	7									
J8	NA	gpmc_wait3	0	I	H	H	7	VDDDS_MEM	Yes	4	PU/PD	LVCMOS
		sys_ndmareq1	1	I								
		gpio_65	4	IO								
		safe_mode	7									
D28	NA	dss_pclk	0	O	H	H	7	VDDDS	Yes	4	PU/PD	LVCMOS
		gpio_66	4	IO								
		safe_mode	7									
D26	NA	dss_hsync	0	O	H	H	7	VDDDS	Yes	4	PU/PD	LVCMOS
		gpio_67	4	IO								
		safe_mode	7									
D27	NA	dss_vsync	0	O	H	H	7	VDDDS	Yes	4	PU/PD	LVCMOS
		gpio_68	4	IO								
		safe_mode	7									
E27	NA	dss_acbias	0	O	L	L	7	VDDDS	Yes	8	PU/PD	LVCMOS
		gpio_69	4	IO								
		safe_mode	7									
AG22	NA	dss_data0	0	IO	L	L	7	VDDDS	No	4	PU/PD	LVDS/CMOS
		uart1_cts	2	I								
		gpio_70	4	IO								
		safe_mode	7									
AH22	NA	dss_data1	0	IO	L	L	7	VDDDS	No	4	PU/PD	LVDS/CMOS
		uart1_rts	2	O								
		gpio_71	4	IO								
		safe_mode	7									
AG23	NA	dss_data2	0	IO	L	L	7	VDDDS	No	4	PU/PD	LVDS/CMOS
		gpio_72	4	IO								
		safe_mode	7									

PRODUCT PREVIEW

Table 2-1. Ball Characteristics (CBB Pkg.)⁽¹⁾ (continued)

BALL BOTTOM [1]	BALL TOP [2]	PIN NAME [3]	MODE [4]	TYPE [5]	BALL RESET STATE [6]	BALL RESET REL. STATE [7]	RESET REL. MODE [8]	POWER [9]	HYS [10]	BUFFER STRENGTH (mA) [11]	PULL U/D TYPE [12]	IO CELL [13]
AH23	NA	dss_data3	0	IO	L	L	7	VDDS	No	4	PU/PD	LVDS/CMOS
		gpio_73	4	IO								
		safe_mode	7									
AG24	NA	dss_data4	0	IO	L	L	7	VDDS	No	4	PU/PD	LVDS/CMOS
		uart3_rx_irrx	2	I								
		gpio_74	4	IO								
		safe_mode	7									
AH24	NA	dss_data5	0	IO	L	L	7	VDDS	No	4	PU/PD	LVDS/CMOS
		uart3_tx_irtx	2	O								
		gpio_75	4	IO								
		safe_mode	7									
E26	NA	dss_data6	0	IO	L	L	7	VDDS	Yes	8	PU/PD	LVCMOS
		uart1_tx	2	O								
		gpio_76	4	IO								
		safe_mode	7									
F28	NA	dss_data7	0	IO	L	L	7	VDDS	Yes	8	PU/PD	LVCMOS
		uart1_rx	2	I								
		gpio_77	4	IO								
		safe_mode	7									
F27	NA	dss_data8	0	IO	L	L	7	VDDS	Yes	8	PU/PD	LVCMOS
		gpio_78	4	IO								
		safe_mode	7									
G26	NA	dss_data9	0	IO	L	L	7	VDDS	Yes	8	PU/PD	LVCMOS
		gpio_79	4	IO								
		safe_mode	7									
AD28	NA	dss_data10	0	IO	L	L	7	VDDS	NA	4	PU/PD	LVDS/CMOS
		gpio_80	4	IO								
		safe_mode	7									
AD27	NA	dss_data11	0	IO	L	L	7	VDDS	NA	4	PU/PD	LVDS/CMOS
		gpio_81	4	IO								
		safe_mode	7									
AB28	NA	dss_data12	0	IO	L	L	7	VDDS	NA	4	PU/PD	LVDS/CMOS
		gpio_82	4	IO								
		safe_mode	7									
AB27	NA	dss_data13	0	IO	L	L	7	VDDS	NA	4	PU/PD	LVDS/CMOS
		gpio_83	4	IO								
		safe_mode	7									

PRODUCT PREVIEW

Table 2-1. Ball Characteristics (CBB Pkg.)⁽¹⁾ (continued)

BALL BOTTOM [1]	BALL TOP [2]	PIN NAME [3]	MODE [4]	TYPE [5]	BALL RESET STATE [6]	BALL RESET REL. STATE [7]	RESET REL. MODE [8]	POWER [9]	HYS [10]	BUFFER STRENGTH (mA) [11]	PULL U/D TYPE [12]	IO CELL [13]
AA28	NA	dss_data14	0	IO	L	L	7	VDDS	NA	4	PU/PD	LVDS/CMOS
		gpio_84	4	IO								
		safe_mode	7									
AA27	NA	dss_data15	0	IO	L	L	7	VDDS	NA	4	PU/PD	LVDS/CMOS
		gpio_85	4	IO								
		safe_mode	7									
G25	NA	dss_data16	0	IO	L	L	7	VDDS	Yes	8	PU/PD	LVCMOS
		gpio_86	4	IO								
		safe_mode	7									
H27	NA	dss_data17	0	IO	L	L	7	VDDS	Yes	8	PU/PD	LVCMOS
		gpio_87	4	IO								
		safe_mode	7									
H26	NA	dss_data18	0	IO	L	L	7	VDDS	Yes	8	PU/PD	LVCMOS
		mcspi3_clk	2	IO								
		dss_data0	3	IO								
		gpio_88	4	IO								
		safe_mode	7									
H25	NA	dss_data19	0	IO	L	L	7	VDDS	Yes	8	PU/PD	LVCMOS
		mcspi3_simo	2	IO								
		dss_data1	3	IO								
		gpio_89	4	IO								
		safe_mode	7									
E28	NA	dss_data20	0	O	H	H	7	VDDS	Yes	4	PU/PD	LVCMOS
		mcspi3_somi	2	IO								
		dss_data2	3	IO								
		gpio_90	4	IO								
		safe_mode	7									
J26	NA	dss_data21	0	O	L	L	7	VDDS	Yes	8	PU/PD	LVCMOS
		mcspi3_cs0	2	IO								
		dss_data3	3	IO								
		gpio_91	4	IO								
		safe_mode	7									
AC27	NA	dss_data22	0	O	L	L	7	VDDS	NA	4	PU/PD	LVDS/CMOS
		mcspi3_cs1	2	O								
		dss_data4	3	IO								
		gpio_92	4	IO								
		safe_mode	7									

PRODUCT PREVIEW

Table 2-1. Ball Characteristics (CBB Pkg.)⁽¹⁾ (continued)

BALL BOTTOM [1]	BALL TOP [2]	PIN NAME [3]	MODE [4]	TYPE [5]	BALL RESET STATE [6]	BALL RESET REL. STATE [7]	RESET REL. MODE [8]	POWER [9]	HYS [10]	BUFFER STRENGTH (mA) [11]	PULL U/D TYPE [12]	IO CELL [13]
AC28	NA	dss_data23	0	O	L	L	7	VDDS	NA	4	PU/PD	LVDS/CMOS
		dss_data5	3	IO								
		gpio_93	4	IO								
		safe_mode	7									
W28	NA	tv_out2	0	O	Z	0	0	VDDADAC		8	NA	10-bit DAC
Y28	NA	tv_out1	0	O	Z	0	0	VDDADAC		8	NA	10-bit DAC
Y27	NA	tv_vfb1	0	O	Z	NA	0	VDDADAC			NA	10-bit DAC
W27	NA	tv_vfb2	0	O	Z	NA	0	VDDADAC			NA	10-bit DAC
W26	NA	tv_vref	0	I	Z	NA	0	VDDADAC			NA	10-bit DAC
A24	NA	cam_hs	0	IO	L	L	7	VDDS	Yes	4	PU/PD	LVCMOS
		gpio_94	4	IO								
		safe_mode	7									
A23	NA	cam_vs	0	IO	L	L	7	VDDS	Yes	4	PU/PD	LVCMOS
		gpio_95	4	IO								
		safe_mode	7									
C25	NA	cam_xclka	0	O	L	L	7	VDDS	Yes	4	PU/PD	LVCMOS
		gpio_96	4	IO								
		safe_mode	7									
C27	NA	cam_pclk	0	I	L	L	7	VDDS	Yes	4	PU/PD	LVCMOS
		gpio_97	4	IO								
		safe_mode	7									
C23	NA	cam_fld	0	IO	L	L	7	VDDS	Yes	4	PU/PD	LVCMOS
		cam_global_reset	2	IO								
		gpio_98	4	IO								
		safe_mode	7									
AG17	NA	cam_d0	0	I	L	L	7	VDDS	Yes	4	PD	LVDS/CMOS
		gpio_99	4	I								
		safe_mode	7									
AH17	NA	cam_d1	0	I	L	L	7	VDDS	Yes	4	PD	LVDS/CMOS
		gpio_100	4	I								
		safe_mode	7									
B24	NA	cam_d2	0	I	L	L	7	VDDS	Yes	4	PU/PD	LVCMOS
		gpio_101	4	IO								
		safe_mode	7									
C24	NA	cam_d3	0	I	L	L	7	VDDS	Yes	4	PU/PD	LVCMOS
		gpio_102	4	IO								

PRODUCT PREVIEW

Table 2-1. Ball Characteristics (CBB Pkg.)⁽¹⁾ (continued)

BALL BOTTOM [1]	BALL TOP [2]	PIN NAME [3]	MODE [4]	TYPE [5]	BALL RESET STATE [6]	BALL RESET REL. STATE [7]	RESET REL. MODE [8]	POWER [9]	HYS [10]	BUFFER STRENGTH (mA) [11]	PULL U/D TYPE [12]	IO CELL [13]
		safe_mode	7									
D24	NA	cam_d4	0	I	L	L	7	VDD5	Yes	4	PU/PD	LVCMOS
		gpio_103	4	IO								
		safe_mode	7									
A25	NA	cam_d5	0	I	L	L	7	VDD5	Yes	4	PU/PD	LVCMOS
		gpio_104	4	IO								
		safe_mode	7									
K28	NA	cam_d6	0	I	L	L	7	VDD5	NA	4	PD	LVDS/CMOS
		gpio_105	4	IO								
		safe_mode	7									
L28	NA	cam_d7	0	I	L	L	7	VDD5	NA	4	PD	LVDS/CMOS
		gpio_106	4	IO								
		safe_mode	7									
K27	NA	cam_d8	0	I	L	L	7	VDD5	NA	4	PD	LVDS/CMOS
		gpio_107	4	IO								
		safe_mode	7									
L27	NA	cam_d9	0	I	L	L	7	VDD5	NA	4	PD	LVDS/CMOS
		gpio_108	4	IO								
		safe_mode	7									
B25	NA	cam_d10	0	I	L	L	7	VDD5	Yes	4	PU/PD	LVCMOS
		gpio_109	4	IO								
		safe_mode	7									
C26	NA	cam_d11	0	I	L	L	7	VDD5	Yes	4	PU/PD	LVCMOS
		gpio_110	4	IO								
		safe_mode	7									
B26	NA	cam_xclkb	0	O	L	L	7	VDD5	Yes	4	PU/PD	LVCMOS
		gpio_111	4	IO								
		safe_mode	7									
B23	NA	cam_wen	0	I	L	L	7	VDD5	Yes	4	PU/PD	LVCMOS
		cam_shutter	2	O								
		gpio_167	4	IO								
		safe_mode	7									
D25	NA	cam_strobe	0	O	L	L	7	VDD5	Yes	4	PU/PD	LVCMOS
		gpio_126	4	IO								
		safe_mode	7									
AG19	NA	gpio_112	4	I	L	L	7	VDD5	Yes	4	PD	LVDS/CMOS
		safe_mode	7									
AH19	NA	gpio_113	4	I	L	L	7	VDD5	Yes	4	PD	LVDS/CMOS
		safe_mode	7									

PRODUCT PREVIEW

Table 2-1. Ball Characteristics (CBB Pkg.)⁽¹⁾ (continued)

BALL BOTTOM [1]	BALL TOP [2]	PIN NAME [3]	MODE [4]	TYPE [5]	BALL RESET STATE [6]	BALL RESET REL. STATE [7]	RESET REL. MODE [8]	POWER [9]	HYS [10]	BUFFER STRENGTH (mA) [11]	PULL U/D TYPE [12]	IO CELL [13]
AG18	NA	gpio_114	4	I	L	L	7	VDDS	Yes	4	PD	LVDS/ CMOS
		safe_mode	7									
AH18	NA	gpio_115	4	I	L	L	7	VDDS	Yes	4	PD	LVDS/ CMOS
		safe_mode	7									
P21	NA	mcbasp2_fsx	0	IO	PGM	L	7	VDDS	Yes	4 ⁽²⁾	PU/ PD	LVCMOS
		gpio_116	4	IO								
		safe_mode	7									
N21	NA	mcbasp2_clkx	0	IO	PGM	L	7	VDDS	Yes	4 ⁽²⁾	PU/ PD	LVCMOS
		gpio_117	4	IO								
		safe_mode	7									
R21	NA	mcbasp2_dr	0	I	PGM	L	7	VDDS	Yes	4 ⁽²⁾	PU/ PD	LVCMOS
		gpio_118	4	IO								
		safe_mode	7									
M21	NA	mcbasp2_dx	0	IO	PGM	L	7	VDDS	Yes	4 ⁽²⁾	PU/ PD	LVCMOS
		gpio_119	4	IO								
		safe_mode	7									
N28	NA	mmc1_clk	0	O	L	L	7	MMC1_ VDDS	Yes	8	PU/ PD	LVCMOS
		ms_clk	1	O								
		gpio_120	4	IO								
		safe_mode	7									
M27	NA	mmc1_cmd	0	IO	L	L	7	MMC1_ VDDS	Yes	8	PU/ PD	LVCMOS
		ms_bs	1	O								
		gpio_121	4	IO								
		safe_mode	7									
N27	NA	mmc1_dat0	0	IO	L	L	7	MMC1_ VDDS	Yes	8	PU/ PD	LVCMOS
		ms_dat0	1	IO								
		gpio_122	4	IO								
		safe_mode	7									
N26	NA	mmc1_dat1	0	IO	L	L	7	MMC1_ VDDS	Yes	8	PU/ PD	LVCMOS
		ms_dat1	1	IO								
		gpio_123	4	IO								
		safe_mode	7									
N25	NA	mmc1_dat2	0	IO	L	L	7	MMC1_ VDDS	Yes	8	PU/ PD	LVCMOS
		ms_dat2	1	IO								
		gpio_124	4	IO								
		safe_mode	7									
P28	NA	mmc1_dat3	0	IO	L	L	7	MMC1_ VDDS	Yes	8	PU/ PD	LVCMOS
		ms_dat3	1	IO								
		gpio_125	4	IO								
		safe_mode	7									
P27	NA	mmc1_dat4	0	IO	L	L	7	VDDS	No	8	PD	LVCMOS
		gpio_126	4	IO								

PRODUCT PREVIEW

Table 2-1. Ball Characteristics (CBB Pkg.)⁽¹⁾ (continued)

BALL BOTTOM [1]	BALL TOP [2]	PIN NAME [3]	MODE [4]	TYPE [5]	BALL RESET STATE [6]	BALL RESET REL. STATE [7]	RESET REL. MODE [8]	POWER [9]	HYS [10]	BUFFER STRENGTH (mA) [11]	PULL U/D TYPE [12]	IO CELL [13]
		safe_mode	7									
P26	NA	mmc1_dat5	0	IO	L	L	7	VDDS	No	8	PD	LVCMOS
		gpio_127	4	IO								
		safe_mode	7									
R27	NA	mmc1_dat6	0	IO	L	L	7	VDDS	No	8	PD	LVCMOS
		gpio_128	4	IO								
		safe_mode	7									
R25	NA	mmc1_dat7	0	IO	L	L	7	VDDS	No	8	PD	LVCMOS
		gpio_129	4	IO								
		safe_mode	7									
AE2	NA	mmc2_clk	0	O	L	L	7	VDDS	Yes	4	PU/PD	LVCMOS
		mcspi3_clk	1	IO								
		gpio_130	4	IO								
		safe_mode	7									
AG5	NA	mmc2_cmd	0	IO	H	H	7	VDDS	Yes	4	PU/PD	LVCMOS
		mcspi3_simo	1	IO								
		gpio_131	4	IO								
		safe_mode	7									
AH5	NA	mmc2_dat0	0	IO	H	H	7	VDDS	Yes	4	PU/PD	LVCMOS
		mcspi3_somi	1	IO								
		gpio_132	4	IO								
		safe_mode	7									
AH4	NA	mmc2_dat1	0	IO	H	H	7	VDDS	Yes	4	PU/PD	LVCMOS
		gpio_133	4	IO								
		safe_mode	7									
AG4	NA	mmc2_dat2	0	IO	H	H	7	VDDS	Yes	4	PU/PD	LVCMOS
		mcspi3_cs1	1	O								
		gpio_134	4	IO								
		safe_mode	7									
AF4	NA	mmc2_dat3	0	IO	H	H	7	VDDS	Yes	4	PU/PD	LVCMOS
		mcspi3_cs0	1	IO								
		gpio_135	4	IO								
		safe_mode	7									
AE4	NA	mmc2_dat4	0	IO	L	L	7	VDDS	Yes	4	PU/PD	LVCMOS
		mmc2_dir_dat0	1	O								
		mmc3_dat0	3	IO								
		gpio_136	4	IO								
		safe_mode	7									

PRODUCT PREVIEW

Table 2-1. Ball Characteristics (CBB Pkg.)⁽¹⁾ (continued)

BALL BOTTOM [1]	BALL TOP [2]	PIN NAME [3]	MODE [4]	TYPE [5]	BALL RESET STATE [6]	BALL RESET REL. STATE [7]	RESET REL. MODE [8]	POWER [9]	HYS [10]	BUFFER STRENGTH (mA) [11]	PULL U/D TYPE [12]	IO CELL [13]
AH3	NA	mmc2_dat5	0	IO	L	L	7	VDDS	Yes	4	PU/PD	LVCMOS
		mmc2_dir_dat1	1	O								
		cam_global_reset	2	IO								
		mmc3_dat1	3	IO								
		gpio_137	4	IO								
		hsusb3_tll_stp	5	IO								
		mm3_rxdp	6	IO								
safe_mode	7											
AF3	NA	mmc2_dat6	0	IO	L	L	7	VDDS	Yes	4	PU/PD	LVCMOS
		mmc2_dir_cmd	1	O								
		cam_shutter	2	O								
		mmc3_dat2	3	IO								
		gpio_138	4	IO								
		hsusb3_tll_dir	5	IO								
		safe_mode	7									
AE3	NA	mmc2_dat7	0	IO	L	L	7	VDDS	Yes	4	PU/PD	LVCMOS
		mmc2_clkin	1	I								
		mmc3_dat3	3	IO								
		gpio_139	4	IO								
		hsusb3_tll_nxt	5	IO								
		mm3_rxdm	6	IO								
		safe_mode	7									
AF6	NA	mcbsp3_dx	0	IO	L	L	7	VDDS	Yes	4	PU/PD	LVCMOS
		uart2_cts	1	I								
		gpio_140	4	IO								
		hsusb3_tll_data4	5	IO								
		safe_mode	7									
AE6	NA	mcbsp3_dr	0	I	L	L	7	VDDS	Yes	4	PU/PD	LVCMOS
		uart2_rts	1	O								
		gpio_141	4	IO								
		hsusb3_tll_data5	5	IO								
		safe_mode	7									

PRODUCT PREVIEW

Table 2-1. Ball Characteristics (CBB Pkg.)⁽¹⁾ (continued)

BALL BOTTOM [1]	BALL TOP [2]	PIN NAME [3]	MODE [4]	TYPE [5]	BALL RESET STATE [6]	BALL RESET REL. STATE [7]	RESET REL. MODE [8]	POWER [9]	HYS [10]	BUFFER STRENGTH (mA) [11]	PULL U/D TYPE [12]	IO CELL [13]
AF5	NA	mcbbsp3_clkx	0	IO	L	L	7	VDDS	Yes	4	PU/PD	LVCMOS
		uart2_tx	1	O								
		gpio_142	4	IO								
		hsusb3_tll_data6	5	IO								
		safe_mode	7									
AE5	NA	mcbbsp3_fsx	0	IO	L	L	7	VDDS	Yes	4	PU/PD	LVCMOS
		uart2_rx	1	I								
		gpio_143	4	IO								
		hsusb3_tll_data7	5	IO								
		safe_mode	7									
AB26	NA	uart2_cts	0	I	H	H	7	VDDS	Yes	4	PU/PD	LVCMOS
		mcbbsp3_dx	1	IO								
		gpt9_pwm_evt	2	IO								
		gpio_144	4	IO								
		safe_mode	7									
AB25	NA	uart2_rts	0	O	H	H	7	VDDS	Yes	4	PU/PD	LVCMOS
		mcbbsp3_dr	1	I								
		gpt10_pwm_evt	2	IO								
		gpio_145	4	IO								
		safe_mode	7									
AA25	NA	uart2_tx	0	O	H	H	7	VDDS	Yes	4	PU/PD	LVCMOS
		mcbbsp3_clkx	1	IO								
		gpt11_pwm_evt	2	IO								
		gpio_146	4	IO								
		safe_mode	7									
AD25	NA	uart2_rx	0	I	H	H	7	VDDS	Yes	4	PU/PD	LVCMOS
		mcbbsp3_fsx	1	IO								
		gpt8_pwm_evt	2	IO								
		gpio_147	4	IO								
		safe_mode	7									
AA8	NA	uart1_tx	0	O	L	L	7	VDDS	Yes	4	PU/PD	LVCMOS
		gpio_148	4	IO								
		safe_mode	7									
AA9	NA	uart1_rts	0	O	L	L	7	VDDS	Yes	4	PU/PD	LVCMOS
		gpio_149	4	IO								
		safe_mode	7									

PRODUCT PREVIEW

Table 2-1. Ball Characteristics (CBB Pkg.)⁽¹⁾ (continued)

BALL BOTTOM [1]	BALL TOP [2]	PIN NAME [3]	MODE [4]	TYPE [5]	BALL RESET STATE [6]	BALL RESET REL. STATE [7]	RESET REL. MODE [8]	POWER [9]	HYS [10]	BUFFER STRENGTH (mA) [11]	PULL U/D TYPE [12]	IO CELL [13]
W8	NA	uart1_cts	0	I	L	L	7	VDDS	Yes	4	PU/PD	LVCMOS
		gpio_150	4	IO								
		hsusb3_tll_clk	5	O								
		safe_mode	7									
Y8	NA	uart1_rx	0	I	L	L	7	VDDS	Yes	4	PU/PD	LVCMOS
		mcbasp1_clkr	2	IO								
		mcspi4_clk	3	IO								
		gpio_151	4	IO								
		safe_mode	7									
AE1	NA	mcbasp4_clkx	0	IO	L	L	7	VDDS	Yes	4	PU/PD	LVCMOS
		gpio_152	4	IO								
		hsusb3_tll_data1	5	IO								
		mm3_txse0	6	IO								
		safe_mode	7									
AD1	NA	mcbasp4_dr	0	I	L	L	7	VDDS	Yes	4	PU/PD	LVCMOS
		gpio_153	4	IO								
		hsusb3_tll_data0	5	IO								
		mm3_rxcv	6	IO								
		safe_mode	7									
AD2	NA	mcbasp4_dx	0	IO	L	L	7	VDDS	Yes	4	PU/PD	LVCMOS
		gpio_154	4	IO								
		hsusb3_tll_data2	5	IO								
		mm3_txd	6	IO								
		safe_mode	7									
AC1	NA	mcbasp4_fsx	0	IO	L	L	7	VDDS	Yes	4	PU/PD	LVCMOS
		gpio_155	4	IO								
		hsusb3_tll_data3	5	IO								
		mm3_txen_n	6	IO								
		safe_mode	7									
Y21	NA	mcbasp1_clkr	0	IO	L	L	7	VDDS	Yes	4	PU/PD	LVCMOS
		mcspi4_clk	1	IO								
		gpio_156	4	IO								
		safe_mode	7									

PRODUCT PREVIEW

Table 2-1. Ball Characteristics (CBB Pkg.)⁽¹⁾ (continued)

BALL BOTTOM [1]	BALL TOP [2]	PIN NAME [3]	MODE [4]	TYPE [5]	BALL RESET STATE [6]	BALL RESET REL. STATE [7]	RESET REL. MODE [8]	POWER [9]	HYS [10]	BUFFER STRENGTH (mA) [11]	PULL U/D TYPE [12]	IO CELL [13]
AA21	NA	mcbbsp1_fsr	0	IO	L	L	7	VDDS	Yes	4	PU/PD	LVCMOS
		adpll2d_dithering_en1	1	I								
		cam_global_reset	2	IO								
		gpio_157	4	IO								
		safe_mode	7									
V21	NA	mcbbsp1_dx	0	IO	L	L	7	VDDS	Yes	4	PU/PD	LVCMOS
		mcspi4_simo	1	IO								
		mcbbsp3_dx	2	IO								
		gpio_158	4	IO								
		safe_mode	7									
U21	NA	mcbbsp1_dr	0	I	L	L	7	VDDS	Yes	4	PU/PD	LVCMOS
		mcspi4_somi	1	IO								
		mcbbsp3_dr	2	O								
		gpio_159	4	IO								
		safe_mode	7									
T21	NA	mcbbsp_clks	0	I	L	L	7	VDDS	Yes	4	PU/PD	LVCMOS
		cam_shutter	2	O								
		gpio_160	4	IO								
		uart1_cts	5	I								
		safe_mode	7									
K26	NA	mcbbsp1_fsx	0	IO	L	L	7	VDDS	Yes	4	PU/PD	LVCMOS
		mcspi4_cs0	1	IO								
		mcbbsp3_fsx	2	IO								
		gpio_161	4	IO								
		safe_mode	7									
W21	NA	mcbbsp1_clkx	0	IO	L	L	7	VDDS	Yes	4	PU/PD	LVCMOS
		mcbbsp3_clkx	2	IO								
		gpio_162	4	IO								
		safe_mode	7									
H18	NA	uart3_cts_rctx	0	IO	H	H	7	VDDS	Yes	4	PU/PD	LVCMOS
		gpio_163	4	IO								
		safe_mode	7									
H19	NA	uart3_rts_sd	0	O	H	H	7	VDDS	Yes	4	PU/PD	LVCMOS
		gpio_164	4	IO								
		safe_mode	7									
H20	NA	uart3_rx_irrx	0	I	H	H	7	VDDS	Yes	4	PU/PD	LVCMOS
		gpio_165	4	IO								

PRODUCT PREVIEW

Table 2-1. Ball Characteristics (CBB Pkg.)⁽¹⁾ (continued)

BALL BOTTOM [1]	BALL TOP [2]	PIN NAME [3]	MODE [4]	TYPE [5]	BALL RESET STATE [6]	BALL RESET REL. STATE [7]	RESET REL. MODE [8]	POWER [9]	HYS [10]	BUFFER STRENGTH (mA) [11]	PULL U/D TYPE [12]	IO CELL [13]
		safe_mode	7									
H21	NA	uart3_tx_irtx	0	O	H	H	7	VDDS	Yes	4	PU/PD	LVCMOS
		gpio_166	4	IO								
		safe_mode	7									
T28	NA	hsusb0_clk	0	I	L	L	7	VDDS	Yes	4	PU/PD	LVCMOS
		gpio_120	4	IO								
		safe_mode	7									
T25	NA	hsusb0_stp	0	O	H	H	7	VDDS	Yes	4	PU/PD	LVCMOS
		gpio_121	4	IO								
		safe_mode	7									
R28	NA	hsusb0_dir	0	I	L	L	7	VDDS	Yes	4	PU/PD	LVCMOS
		gpio_122	4	IO								
		safe_mode	7									
T26	NA	hsusb0_nxt	0	I	L	L	7	VDDS	Yes	4	PU/PD	LVCMOS
		gpio_124	4	IO								
		safe_mode	7									
T27	NA	hsusb0_data0	0	IO	L	L	7	VDDS	Yes	4	PU/PD	LVCMOS
		uart3_tx_irtx	2	O								
		gpio_125	4	IO								
		safe_mode	7									
U28	NA	hsusb0_data1	0	IO	L	L	7	VDDS	Yes	4	PU/PD	LVCMOS
		uart3_rx_irrx	2	I								
		gpio_130	4	IO								
		safe_mode	7									
U27	NA	hsusb0_data2	0	IO	L	L	7	VDDS	Yes	4	PU/PD	LVCMOS
		uart3_rts_sd	2	O								
		gpio_131	4	IO								
		safe_mode	7									
U26	NA	hsusb0_data3	0	IO	L	L	7	VDDS	Yes	4	PU/PD	LVCMOS
		uart3_cts_rctx	2	IO								
		gpio_169	4	IO								
		safe_mode	7									
U25	NA	hsusb0_data4	0	IO	L	L	7	VDDS	Yes	4	PU/PD	LVCMOS
		gpio_188	4	IO								
		safe_mode	7									
V28	NA	hsusb0_data5	0	IO	L	L	7	VDDS	Yes	4	PU/PD	LVCMOS
		gpio_189	4	IO								

PRODUCT PREVIEW

Table 2-1. Ball Characteristics (CBB Pkg.)⁽¹⁾ (continued)

BALL BOTTOM [1]	BALL TOP [2]	PIN NAME [3]	MODE [4]	TYPE [5]	BALL RESET STATE [6]	BALL RESET REL. STATE [7]	RESET REL. MODE [8]	POWER [9]	HYS [10]	BUFFER STRENGTH (mA) [11]	PULL U/D TYPE [12]	IO CELL [13]
		safe_mode	7									
V27	NA	hsusb0_data6	0	IO	L	L	7	VDDS	Yes	4	PU/PD	LVCMOS
		gpio_190	4	IO								
		safe_mode	7									
V26	NA	hsusb0_data7	0	IO	L	L	7	VDDS	Yes	4	PU/PD	LVCMOS
		gpio_191	4	IO								
		safe_mode	7									
K21	NA	i2c1_scl	0	IOD	H	H	0	VDDS	Yes	4	PU/PD	Open Drain
J21	NA	i2c1_sda	0	IOD	H	H	0	VDDS	Yes	4	PU/PD	Open Drain
AF15	NA	i2c2_scl	0	IOD	H	H	7	VDDS	Yes	4	PU/PD	Open Drain
		gpio_168	4	IO								
		safe_mode	7									
AE15	NA	i2c2_sda	0	IOD	H	H	7	VDDS	Yes	4	PU/PD	Open Drain
		gpio_183	4	IO								
		safe_mode	7									
AF14	NA	i2c3_scl	0	IOD	H	H	7	VDDS	Yes	4	PU/PD	Open Drain
		gpio_184	4	IO								
		safe_mode	7									
AG14	NA	i2c3_sda	0	IOD	H	H	7	VDDS	Yes	4	PU/PD	Open Drain
		gpio_185	4	IO								
		safe_mode	7									
AD26	NA	i2c4_scl	0	IOD	H	H	0	VDDS	Yes	4	PU/PD	Open Drain
		sys_nvmode1	1	O								
		safe_mode	7									
AE26	NA	i2c4_sda	0	IOD	H	H	0	VDDS	Yes	4	PU/PD	Open Drain
		sys_nvmode2	1	O								
		safe_mode	7									
J25	NA	hdq_sio	0	IOD	H	H	7	VDDS	Yes	4	PU/PD	LVCMOS
		sys_altclk	1	I								
		i2c2_sccbe	2	O								
		i2c3_sccbe	3	O								
		gpio_170	4	IO								
		safe_mode	7									
AB3	NA	mcspi1_clk	0	IO	PGM	L	7	VDDS	Yes	4 ⁽²⁾	PU/PD	LVCMOS
		mmc2_dat4	1	IO								
		gpio_171	4	IO								
		safe_mode	7									

PRODUCT PREVIEW

Table 2-1. Ball Characteristics (CBB Pkg.)⁽¹⁾ (continued)

BALL BOTTOM [1]	BALL TOP [2]	PIN NAME [3]	MODE [4]	TYPE [5]	BALL RESET STATE [6]	BALL RESET REL. STATE [7]	RESET REL. MODE [8]	POWER [9]	HYS [10]	BUFFER STRENGTH (mA) [11]	PULL U/D TYPE [12]	IO CELL [13]
AB4	NA	mcspi1_simo	0	IO	PGM	L	7	VDDS	Yes	4 ⁽²⁾	PU/PD	LVCMOS
		mmc2_dat5	1	IO								
		gpio_172	4	IO								
		safe_mode	7									
AA4	NA	mcspi1_somi	0	IO	PGM	L	7	VDDS	Yes	4 ⁽²⁾	PU/PD	LVCMOS
		mmc2_dat6	1	IO								
		gpio_173	4	IO								
		safe_mode	7									
AC2	NA	mcspi1_cs0	0	IO	PGM	H	7	VDDS	Yes	4 ⁽²⁾	PU/PD	LVCMOS
		mmc2_dat7	1	IO								
		gpio_174	4	IO								
		safe_mode	7									
AC3	NA	mcspi1_cs1	0	O	PGM	H	7	VDDS	Yes	4 ⁽²⁾	PU/PD	LVCMOS
		adpll2d_dithering_en2	1	I								
		mmc3_cmd	3	IO								
		gpio_175	4	IO								
		safe_mode	7									
AB1	NA	mcspi1_cs2	0	O	PGM	H	7	VDDS	Yes	4 ⁽²⁾	PU/PD	LVCMOS
		mmc3_clk	3	O								
		gpio_176	4	IO								
		safe_mode	7									
AB2	NA	mcspi1_cs3	0	O	H	H	7	VDDS	Yes	4	PU/PD	LVCMOS
		hsusb2_tll_data2	2	IO								
		hsusb2_data2	3	IO								
		gpio_177	4	IO								
		mm2_txdat	5	IO								
		safe_mode	7									
AA3	NA	mcspi2_clk	0	IO	L	L	7	VDDS	Yes	4	PU/PD	LVCMOS
		hsusb2_tll_data7	2	IO								
		hsusb2_data7	3	O								
		gpio_178	4	IO								
		safe_mode	7									
Y2	NA	mcspi2_simo	0	IO	L	L	7	VDDS	Yes	4	PU/PD	LVCMOS
		gpt9_pwm_evt	1	IO								
		hsusb2_tll_data4	2	IO								
		hsusb2_data4	3	I								
		gpio_179	4	IO								

PRODUCT PREVIEW

Table 2-1. Ball Characteristics (CBB Pkg.)⁽¹⁾ (continued)

BALL BOTTOM [1]	BALL TOP [2]	PIN NAME [3]	MODE [4]	TYPE [5]	BALL RESET STATE [6]	BALL RESET REL. STATE [7]	RESET REL. MODE [8]	POWER [9]	HYS [10]	BUFFER STRENGTH (mA) [11]	PULL U/D TYPE [12]	IO CELL [13]
		safe_mode	7									
Y3	NA	mcspi2_somi	0	IO	L	L	7	VDDS	Yes	4	PU/PD	LVCMOS
		gpt10_pwm_evt	1	IO								
		hsusb2_tll_data5	2	IO								
		hsusb2_data5	3	O								
		gpio_180	4	IO								
safe_mode	7											
Y4	NA	mcspi2_cs0	0	IO	H	H	7	VDDS	Yes	4	PU/PD	LVCMOS
		gpt11_pwm_evt	1	IO								
		hsusb2_tll_data6	2	IO								
		hsusb2_data6	3	O								
		gpio_181	4	IO								
safe_mode	7											
V3	NA	mcspi2_cs1	0	O	L	L	7	VDDS	Yes	4	PU/PD	LVCMOS
		gpt8_pwm_evt	1	IO								
		hsusb2_tll_data3	2	IO								
		hsusb2_data3	3	IO								
		gpio_182	4	IO								
		mm2_txen_n	5	IO								
safe_mode	7											
AE25	NA	sys_32k	0	I	Z	I	NA	VDDS	Yes	NA	NA	LVCMOS
AE17	NA	sys_xtalin	0	I	Z	I	NA	VDDS	Yes		NA	LVCMOS
AF17	NA	sys_xtalout	0	O	Z	O	NA	VDDS	Yes		NA	LVCMOS
AF25	NA	sys_clkreq	0	IO	0	1	0	VDDS	Yes	4	PU/PD	LVCMOS
		gpio_1	4	IO								
		safe_mode	7									
AF26	NA	sys_nirq	0	I	H	H	7	VDDS	Yes	4	PU/PD	LVCMOS
		gpio_0	4	IO								
		safe_mode	7									
AH25	NA	sys_nrespwron	0	I	Z	I	NA	VDDS	Yes	NA	NA	LVCMOS
AF24	NA	sys_nreswarm	0	IOD	0	1 (PU)	0	VDDS	Yes	4	PU/PD	LVCMOS
		gpio_30	4	IO								
		safe_mode	7									
AH26	NA	sys_boot0	0	I	Z	Z	0	VDDS	Yes	4	PU/PD	LVCMOS
		gpio_2	4	IO								

PRODUCT PREVIEW

Table 2-1. Ball Characteristics (CBB Pkg.)⁽¹⁾ (continued)

BALL BOTTOM [1]	BALL TOP [2]	PIN NAME [3]	MODE [4]	TYPE [5]	BALL RESET STATE [6]	BALL RESET REL. STATE [7]	RESET REL. MODE [8]	POWER [9]	HYS [10]	BUFFER STRENGTH (mA) [11]	PULL U/D TYPE [12]	IO CELL [13]
		safe_mode	7									
AG26	NA	sys_boot1	0	I	Z	Z	0	VDDS	Yes	4	PU/PD	LVCMOS
		gpio_3	4	IO								
		safe_mode	7									
AE14	NA	sys_boot2	0	I	Z	Z	0	VDDS	Yes	4	PU/PD	LVCMOS
		gpio_4	4	IO								
		safe_mode	7									
AF18	NA	sys_boot3	0	I	Z	Z	0	VDDS	Yes	4	PU/PD	LVCMOS
		gpio_5	4	IO								
		safe_mode	7									
AF19	NA	sys_boot4	0	I	Z	Z	0	VDDS	Yes	4	PU/PD	LVCMOS
		mmc2_dir_dat2	1	O								
		gpio_6	4	IO								
		safe_mode	7									
AE21	NA	sys_boot5	0	I	Z	Z	0	VDDS	Yes	4	PU/PD	LVCMOS
		mmc2_dir_dat3	1	O								
		gpio_7	4	IO								
		safe_mode	7									
AF21	NA	sys_boot6	0	I	Z	Z	0	VDDS	Yes	4	PU/PD	LVCMOS
		gpio_8	4	IO								
		safe_mode	7									
AF22	NA	sys_off_mode	0	O	0	L	7	VDDS	Yes	4	PU/PD	LVCMOS
		gpio_9	4	IO								
		safe_mode	7									
AG25	NA	sys_clkout1	0	O	L	L	7	VDDS	Yes	4	PU/PD	LVCMOS
		gpio_10	4	IO								
		safe_mode	7									
AE22	NA	sys_clkout2	0	O	L	L	7	VDDS	Yes	4	PU/PD	LVCMOS
		gpio_186	4	IO								
		safe_mode	7									
B1	NA	sys_ipmcsws	0	AI	Z	AI	NA	VDDS	NA	NA	NA	Analog
A1	NA	sys_opmcsws	0	AO	0	AO	NA	VDDS	No	NA	NA	LVCMOS
AA17	NA	jtag_nrst	0	I	L	L	0	VDDS	Yes	NA	PU/PD	LVCMOS
AA13	NA	jtag_tck	0	I	L	L	0	VDDS	Yes	NA	PU/PD	LVCMOS
AA12	NA	jtag_rtck	0	O	L	0	0	VDDS	Yes	4	PU/PD	LVCMOS
AA18	NA	jtag_tms_tm_sc	0	IO	H	H	0	VDDS	Yes	4	PU/PD	LVCMOS
AA20	NA	jtag_tdi	0	I	H	H	0	VDDS	Yes	NA	PU/PD	LVCMOS

PRODUCT PREVIEW

Table 2-1. Ball Characteristics (CBB Pkg.)⁽¹⁾ (continued)

BALL BOTTOM [1]	BALL TOP [2]	PIN NAME [3]	MODE [4]	TYPE [5]	BALL RESET STATE [6]	BALL RESET REL. STATE [7]	RESET REL. MODE [8]	POWER [9]	HYS [10]	BUFFER STRENGTH (mA) [11]	PULL U/D TYPE [12]	IO CELL [13]
AA19	NA	jtag_tdo	0	O	L	Z	0	VDDS	Yes	4	PU/PD	LVC MOS
AA11	NA	jtag_emu0	0	IO	H	H	0	VDDS	Yes	4	PU/PD	LVC MOS
		gpio_11	4	IO								
		safe_mode	7									
AA10	NA	jtag_emu1	0	IO	H	H	0	VDDS	Yes	4	PU/PD	LVC MOS
		gpio_31	4	IO								
		safe_mode	7									
AF10	NA	etk_clk	0	O	H	H	4	VDDS	Yes	4	PU/PD	LVC MOS
		mcbasp5_clkx	1	IO								
		mmc3_clk	2	O								
		hsusb1_stp	3	O								
		gpio_12	4	IO								
		mm1_rxdp	5	IO								
		hsusb1_tll_stp	6	I								
AE10	NA	etk_ctl	0	O	H	H	4	VDDS	Yes	4	PU/PD	LVC MOS
		mmc3_cmd	2	IO								
		hsusb1_clk	3	O								
		gpio_13	4	IO								
		hsusb1_tll_clk	6	O								
AF11	NA	etk_d0	0	O	H	H	4	VDDS	Yes	4	PU/PD	LVC MOS
		mcspi3_simo	1	IO								
		mmc3_dat4	2	IO								
		hsusb1_data0	3	IO								
		gpio_14	4	IO								
		mm1_rxcv	5	IO								
		hsusb1_tll_data0	6	IO								
AG12	NA	etk_d1	0	O	H	H	4	VDDS	Yes	4	PU/PD	LVC MOS
		mcspi3_somi	1	IO								
		hsusb1_data1	3	IO								
		gpio_15	4	IO								
		mm1_txse0	5	IO								
		hsusb1_tll_data1	6	IO								

PRODUCT PREVIEW

Table 2-1. Ball Characteristics (CBB Pkg.)⁽¹⁾ (continued)

BALL BOTTOM [1]	BALL TOP [2]	PIN NAME [3]	MODE [4]	TYPE [5]	BALL RESET STATE [6]	BALL RESET REL. STATE [7]	RESET REL. MODE [8]	POWER [9]	HYS [10]	BUFFER STRENGTH (mA) [11]	PULL U/D TYPE [12]	IO CELL [13]
AH12	NA	etk_d2	0	O	H	H	4	VDDS	Yes	4	PU/ PD	LVCMOS
		mcspi3_cs0	1	IO								
		hsusb1_data2	3	IO								
		gpio_16	4	IO								
		mm1_txdat	5	IO								
		hsusb1_tll_data2	6	IO								
AE13	NA	etk_d3	0	O	H	H	4	VDDS	Yes	4	PU/ PD	LVCMOS
		mcspi3_clk	1	IO								
		mmc3_dat3	2	IO								
		hsusb1_data7	3	IO								
		gpio_17	4	IO								
		hsusb1_tll_data7	6	IO								
AE11	NA	etk_d4	0	O	L	L	4	VDDS	Yes	4	PU/ PD	LVCMOS
		mcbasp5_dr	1	I								
		mmc3_dat0	2	IO								
		hsusb1_data4	3	IO								
		gpio_18	4	IO								
		hsusb1_tll_data4	6	IO								
AH9	NA	etk_d5	0	O	L	L	4	VDDS	Yes	4	PU/ PD	LVCMOS
		mcbasp5_fsx	1	IO								
		mmc3_dat1	2	IO								
		hsusb1_data5	3	IO								
		gpio_19	4	IO								
		hsusb1_tll_data5	6	IO								
AF13	NA	etk_d6	0	O	L	L	4	VDDS	Yes	4	PU/ PD	LVCMOS
		mcbasp5_dx	1	IO								
		mmc3_dat2	2	IO								
		hsusb1_data6	3	IO								
		gpio_20	4	IO								
		hsusb1_tll_data6	6	IO								
AH14	NA	etk_d7	0	O	L	L	4	VDDS	Yes	4	PU/ PD	LVCMOS
		mcspi3_cs1	1	O								
		mmc3_dat7	2	IO								
		hsusb1_data3	3	IO								
		gpio_21	4	IO								
		mm1_txen_n	5	IO								

PRODUCT PREVIEW

Table 2-1. Ball Characteristics (CBB Pkg.)⁽¹⁾ (continued)

BALL BOTTOM [1]	BALL TOP [2]	PIN NAME [3]	MODE [4]	TYPE [5]	BALL RESET STATE [6]	BALL RESET REL. STATE [7]	RESET REL. MODE [8]	POWER [9]	HYS [10]	BUFFER STRENGTH (mA) [11]	PULL U/D TYPE [12]	IO CELL [13]
		hsusb1_tll_data3	6	IO								
AF9	NA	etk_d8	0	O	L	L	4	VDDS	Yes	4	PU/PD	LVCMOS
		sys_drm_msecure	1	O								
		mmc3_dat6	2	IO								
		hsusb1_dir	3	I								
		gpio_22	4	IO								
hsusb1_tll_dir	6	O										
AG9	NA	etk_d9	0	O	L	L	4	VDDS	Yes	4	PU/PD	LVCMOS
		sys_secure_indicator	1	O								
		mmc3_dat5	2	IO								
		hsusb1_nxt	3	I								
		gpio_23	4	IO								
		mm1_rxdm	5	IO								
hsusb1_tll_nxt	6	O										
AE7	NA	etk_d10	0	O	L	L	4	VDDS	Yes	4	PU/PD	LVCMOS
		uart1_rx	2	I								
		hsusb2_clk	3	O								
		gpio_24	4	IO								
hsusb2_tll_clk	6	O										
AF7	NA	etk_d11	0	O	L	L	4	VDDS	Yes	4	PU/PD	LVCMOS
		hsusb2_stp	3	O								
		gpio_25	4	IO								
		mm2_rxdp	5	IO								
hsusb2_tll_stp	6	I										
AG7	NA	etk_d12	0	O	L	L	4	VDDS	Yes	4	PU/PD	LVCMOS
		hsusb2_dir	3	I								
		gpio_26	4	IO								
hsusb2_tll_dir	6	O										
AH7	NA	etk_d13	0	O	L	L	4	VDDS	Yes	4	PU/PD	LVCMOS
		hsusb2_nxt	3	I								
		gpio_27	4	IO								
		mm2_rxdm	5	IO								
hsusb2_tll_nxt	6	O										

PRODUCT PREVIEW

Table 2-1. Ball Characteristics (CBB Pkg.)⁽¹⁾ (continued)

BALL BOTTOM [1]	BALL TOP [2]	PIN NAME [3]	MODE [4]	TYPE [5]	BALL RESET STATE [6]	BALL RESET REL. STATE [7]	RESET REL. MODE [8]	POWER [9]	HYS [10]	BUFFER STRENGTH (mA) [11]	PULL U/D TYPE [12]	IO CELL [13]
AG8	NA	etk_d14	0	O	L	L	4	VDDS	Yes	4	PU/PD	LVCMOS
		hsusb2_data0	3	IO								
		gpio_28	4	IO								
		mm2_rxcv	5	IO								
		hsusb2_tll_data0	6	IO								
AH8	NA	etk_d15	0	O	L	L	4	VDDS	Yes	4	PU/PD	LVCMOS
		hsusb2_data1	3	IO								
		gpio_29	4	IO								
		mm2_txse0	5	IO								
		hsusb2_tll_data1	6	IO								

(1) NA in this table stands for Not Applicable.

(2) The buffer strength of this IO cell is programmable (2, 4, 6, or 8 mA) according to the selected mode; the default value is described in the above table.

Table 2-2. Ball Characteristics (CUS Pkg.)⁽¹⁾

BALL BOTTOM [1]	PIN NAME [3]	MODE [4]	TYPE [5]	BALL RESET STATE [6]	BALL RESET REL. STATE [7]	RESET REL. MODE [8]	POWER [9]	HYS [10]	BUFFER STRENGTH (mA) [11]	PULL U/D TYPE [12]	IO CELL [13]
D7	sdrc_d0	0	IO	L	Z	0	VDDSD_MEM	Yes	4	PU/ PD	LVC MOS
C5	sdrc_d1	0	IO	L	Z	0	VDDSD_MEM	Yes	4	PU/ PD	LVC MOS
C6	sdrc_d2	0	IO	L	Z	0	VDDSD_MEM	Yes	4	PU/ PD	LVC MOS
B5	sdrc_d3	0	IO	L	Z	0	VDDSD_MEM	Yes	4	PU/ PD	LVC MOS
D9	sdrc_d4	0	IO	L	Z	0	VDDSD_MEM	Yes	4	PU/ PD	LVC MOS
D10	sdrc_d5	0	IO	L	Z	0	VDDSD_MEM	Yes	4	PU/ PD	LVC MOS
C7	sdrc_d6	0	IO	L	Z	0	VDDSD_MEM	Yes	4	PU/ PD	LVC MOS
B7	sdrc_d7	0	IO	L	Z	0	VDDSD_MEM	Yes	4	PU/ PD	LVC MOS
B11	sdrc_d8	0	IO	L	Z	0	VDDSD_MEM	Yes	4	PU/ PD	LVC MOS
C12	sdrc_d9	0	IO	L	Z	0	VDDSD_MEM	Yes	4	PU/ PD	LVC MOS
B12	sdrc_d10	0	IO	L	Z	0	VDDSD_MEM	Yes	4	PU/ PD	LVC MOS
D13	sdrc_d11	0	IO	L	Z	0	VDDSD_MEM	Yes	4	PU/ PD	LVC MOS
C13	sdrc_d12	0	IO	L	Z	0	VDDSD_MEM	Yes	4	PU/ PD	LVC MOS
B14	sdrc_d13	0	IO	L	Z	0	VDDSD_MEM	Yes	4	PU/ PD	LVC MOS
A14	sdrc_d14	0	IO	L	Z	0	VDDSD_MEM	Yes	4	PU/ PD	LVC MOS
B15	sdrc_d15	0	IO	L	Z	0	VDDSD_MEM	Yes	4	PU/ PD	LVC MOS
C9	sdrc_d16	0	IO	L	Z	0	VDDSD_MEM	Yes	4	PU/ PD	LVC MOS
E12	sdrc_d17	0	IO	L	Z	0	VDDSD_MEM	Yes	4	PU/ PD	LVC MOS
B8	sdrc_d18	0	IO	L	Z	0	VDDSD_MEM	Yes	4	PU/ PD	LVC MOS
B9	sdrc_d19	0	IO	L	Z	0	VDDSD_MEM	Yes	4	PU/ PD	LVC MOS
C10	sdrc_d20	0	IO	L	Z	0	VDDSD_MEM	Yes	4	PU/ PD	LVC MOS
B10	sdrc_d21	0	IO	L	Z	0	VDDSD_MEM	Yes	4	PU/ PD	LVC MOS
D12	sdrc_d22	0	IO	L	Z	0	VDDSD_MEM	Yes	4	PU/ PD	LVC MOS
E13	sdrc_d23	0	IO	L	Z	0	VDDSD_MEM	Yes	4	PU/ PD	LVC MOS
E15	sdrc_d24	0	IO	L	Z	0	VDDSD_MEM	Yes	4	PU/ PD	LVC MOS
D15	sdrc_d25	0	IO	L	Z	0	VDDSD_MEM	Yes	4	PU/ PD	LVC MOS
C15	sdrc_d26	0	IO	L	Z	0	VDDSD_MEM	Yes	4	PU/ PD	LVC MOS
B16	sdrc_d27	0	IO	L	Z	0	VDDSD_MEM	Yes	4	PU/ PD	LVC MOS
C16	sdrc_d28	0	IO	L	Z	0	VDDSD_MEM	Yes	4	PU/ PD	LVC MOS
D16	sdrc_d29	0	IO	L	Z	0	VDDSD_MEM	Yes	4	PU/ PD	LVC MOS
B17	sdrc_d30	0	IO	L	Z	0	VDDSD_MEM	Yes	4	PU/ PD	LVC MOS
B18	sdrc_d31	0	IO	L	Z	0	VDDSD_MEM	Yes	4	PU/ PD	LVC MOS
C18	sdrc_ba0	0	O	0	0	0	VDDSD_MEM	No	4	NA	LVC MOS
D18	sdrc_ba1	0	O	0	0	0	VDDSD_MEM	No	4	NA	LVC MOS
A4	sdrc_a0	0	O	0	0	0	VDDSD_MEM	No	4	NA	LVC MOS
B4	sdrc_a1	0	O	0	0	0	VDDSD_MEM	No	4	NA	LVC MOS
D6	sdrc_a2	0	O	0	0	0	VDDSD_MEM	No	4	NA	LVC MOS
B3	sdrc_a3	0	O	0	0	0	VDDSD_MEM	No	4	NA	LVC MOS
B2	sdrc_a4	0	O	0	0	0	VDDSD_MEM	No	4	NA	LVC MOS
C3	sdrc_a5	0	O	0	0	0	VDDSD_MEM	No	4	NA	LVC MOS
E3	sdrc_a6	0	O	0	0	0	VDDSD_MEM	No	4	NA	LVC MOS
F6	sdrc_a7	0	O	0	0	0	VDDSD_MEM	No	4	NA	LVC MOS
E10	sdrc_a8	0	O	0	0	0	VDDSD_MEM	No	4	NA	LVC MOS
E9	sdrc_a9	0	O	0	0	0	VDDSD_MEM	No	4	NA	LVC MOS

PRODUCT PREVIEW

Table 2-2. Ball Characteristics (CUS Pkg.)⁽¹⁾ (continued)

BALL BOTTOM [1]	PIN NAME [3]	MODE [4]	TYPE [5]	BALL RESET STATE [6]	BALL RESET REL. STATE [7]	RESET REL. MODE [8]	POWER [9]	HYS [10]	BUFFER STRENGTH (mA) [11]	PULL U/D TYPE [12]	IO CELL [13]
E7	sdrc_a10	0	O	0	0	0	VDDSD_MEM	No	4	NA	LVC MOS
G6	sdrc_a11	0	O	0	0	0	VDDSD_MEM	No	4	NA	LVC MOS
G7	sdrc_a12	0	O	0	0	0	VDDSD_MEM	No	4	NA	LVC MOS
F7	sdrc_a13	0	O	0	0	0	VDDSD_MEM	No	4	NA	LVC MOS
F9	sdrc_a14	0	O	0	0	0	VDDSD_MEM	No	4	NA	LVC MOS
A19	sdrc_ncs0	0	O	1	1	0	VDDSD_MEM	No	4	NA	LVC MOS
B19	sdrc_ncs1	0	O	1	1	0	VDDSD_MEM	No	4	NA	LVC MOS
A10	sdrc_clk	0	IO	L	0	0	VDDSD_MEM	Yes	4	PU/ PD	LVC MOS
A11	sdrc_nclk	0	O	1	1	0	VDDSD_MEM	No	4	NA	LVC MOS
B20	sdrc_cke0	0	O	H	1	7	VDDSD_MEM	Yes	4	PU/ PD	LVC MOS
	safe_mode	7									
C20	sdrc_cke1	0	O	H	1	7	VDDSD_MEM	Yes	4	PU/ PD	LVC MOS
	safe_mode	7									
D19	sdrc_nras	0	O	1	1	0	VDDSD_MEM	No	4	NA	LVC MOS
C19	sdrc_ncas	0	O	1	1	0	VDDSD_MEM	No	4	NA	LVC MOS
A20	sdrc_nwe	0	O	1	1	0	VDDSD_MEM	No	4	NA	LVC MOS
B6	sdrc_dm0	0	O	0	0	0	VDDSD_MEM	No	4	NA	LVC MOS
B13	sdrc_dm1	0	O	0	0	0	VDDSD_MEM	No	4	NA	LVC MOS
A7	sdrc_dm2	0	O	0	0	0	VDDSD_MEM	No	4	NA	LVC MOS
A16	sdrc_dm3	0	O	0	0	0	VDDSD_MEM	No	4	NA	LVC MOS
A5	sdrc_dqs0	0	IO	L	Z	0	VDDSD_MEM	Yes	4	PU/ PD	LVC MOS
A13	sdrc_dqs1	0	IO	L	Z	0	VDDSD_MEM	Yes	4	PU/ PD	LVC MOS
A8	sdrc_dqs2	0	IO	L	Z	0	VDDSD_MEM	Yes	4	PU/ PD	LVC MOS
A17	sdrc_dqs3	0	IO	L	Z	0	VDDSD_MEM	Yes	4	PU/ PD	LVC MOS
K4	gpmc_a1	0	O	L	L	7	VDDSD_MEM	Yes	4	PU/ PD	LVC MOS
	gpio_34	4	IO								
	safe_mode	7									
K3	gpmc_a2	0	O	L	L	7	VDDSD_MEM	Yes	4	PU/ PD	LVC MOS
	gpio_35	4	IO								
	safe_mode	7									
K2	gpmc_a3	0	O	L	L	7	VDDSD_MEM	Yes	4	PU/ PD	LVC MOS
	gpio_36	4	IO								
	safe_mode	7									
J4	gpmc_a4	0	O	L	L	7	VDDSD_MEM	Yes	4	PU/ PD	LVC MOS
	gpio_37	4	IO								
	safe_mode	7									
J3	gpmc_a5	0	O	L	L	7	VDDSD_MEM	Yes	4	PU/ PD	LVC MOS
	gpio_38	4	IO								
	safe_mode	7									
J2	gpmc_a6	0	O	H	H	7	VDDSD_MEM	Yes	4	PU/ PD	LVC MOS
	gpio_39	4	IO								
	safe_mode	7									
J1	gpmc_a7	0	O	H	H	7	VDDSD_MEM	Yes	4	PU/ PD	LVC MOS
	gpio_40	4	IO								

PRODUCT PREVIEW

Table 2-2. Ball Characteristics (CUS Pkg.)⁽¹⁾ (continued)

BALL BOTTOM [1]	PIN NAME [3]	MODE [4]	TYPE [5]	BALL RESET STATE [6]	BALL RESET REL. STATE [7]	RESET REL. MODE [8]	POWER [9]	HYS [10]	BUFFER STRENGTH (mA) [11]	PULL U/D TYPE [12]	IO CELL [13]
	safe_mode	7									
H1	gpmc_a8	0	O	H	H	7	VDDSD_MEM	Yes	4	PU/ PD	LVCMOS
	gpio_41	4	IO								
	safe_mode	7									
H2	gpmc_a9	0	O	H	H	7	VDDSD_MEM	Yes	4	PU/ PD	LVCMOS
	sys_ndmareq2	1	I								
	gpio_42	4	IO								
	safe_mode	7									
G2	gpmc_a10	0	O	H	H	7	VDDSD_MEM	Yes	4	PU/ PD	LVCMOS
	sys_ndmareq3	1	I								
	gpio_43	4	IO								
	safe_mode	7									
L2	gpmc_d0	0	IO	H	H	0	VDDSD_MEM	Yes	4	PU/ PD	LVCMOS
M1	gpmc_d1	0	IO	H	H	0	VDDSD_MEM	Yes	4	PU/ PD	LVCMOS
M2	gpmc_d2	0	IO	H	H	0	VDDSD_MEM	Yes	4	PU/ PD	LVCMOS
N2	gpmc_d3	0	IO	H	H	0	VDDSD_MEM	Yes	4	PU/ PD	LVCMOS
M3	gpmc_d4	0	IO	H	H	0	VDDSD_MEM	Yes	4	PU/ PD	LVCMOS
P1	gpmc_d5	0	IO	H	H	0	VDDSD_MEM	Yes	4	PU/ PD	LVCMOS
P2	gpmc_d6	0	IO	H	H	0	VDDSD_MEM	Yes	4	PU/ PD	LVCMOS
R1	gpmc_d7	0	IO	H	H	0	VDDSD_MEM	Yes	4	PU/ PD	LVCMOS
R2	gpmc_d8	0	IO	H	H	0	VDDSD_MEM	Yes	4	PU/ PD	LVCMOS
	gpio_44	4	IO								
	safe_mode	7									
T2	gpmc_d9	0	IO	H	H	0	VDDSD_MEM	Yes	4	PU/ PD	LVCMOS
	gpio_45	4	IO								
	safe_mode	7									
U1	gpmc_d10	0	IO	H	H	0	VDDSD_MEM	Yes	4	PU/ PD	LVCMOS
	gpio_46	4	IO								
	safe_mode	7									
R3	gpmc_d11	0	IO	H	H	0	VDDSD_MEM	Yes	4	PU/ PD	LVCMOS
	gpio_47	4	IO								
	safe_mode	7									
T3	gpmc_d12	0	IO	H	H	0	VDDSD_MEM	Yes	4	PU/ PD	LVCMOS
	gpio_48	4	IO								
	safe_mode	7									
U2	gpmc_d13	0	IO	H	H	0	VDDSD_MEM	Yes	4	PU/ PD	LVCMOS
	gpio_49	4	IO								
	safe_mode	7									
V1	gpmc_d14	0	IO	H	H	0	VDDSD_MEM	Yes	4	PU/ PD	LVCMOS
	gpio_50	4	IO								
	safe_mode	7									
V2	gpmc_d15	0	IO	H	H	0	VDDSD_MEM	Yes	4	PU/ PD	LVCMOS
	gpio_51	4	IO								

PRODUCT PREVIEW

Table 2-2. Ball Characteristics (CUS Pkg.)⁽¹⁾ (continued)

BALL BOTTOM [1]	PIN NAME [3]	MODE [4]	TYPE [5]	BALL RESET STATE [6]	BALL RESET REL. STATE [7]	RESET REL. MODE [8]	POWER [9]	HYS [10]	BUFFER STRENGTH (mA) [11]	PULL U/D TYPE [12]	IO CELL [13]
	safe_mode	7									
E2	gpmc_ncs0	0	O	1	1	0	VDDS_MEM	No	4	NA	LVC MOS
D2	gpmc_ncs3	0	O	H	H	7	VDDS_MEM	Yes	4	PU/ PD	LVC MOS
	sys_ndmareq0	1	I								
	gpio_54	4	IO								
	safe_mode	7									
F4	gpmc_ncs4	0	O	H	H	7	VDDS_MEM	Yes	4	PU/ PD	LVC MOS
	sys_ndmareq1	1	I								
	mcbasp4_clkx	2	IO								
	gpt9_pwm_evt	3	IO								
	gpio_55	4	IO								
	safe_mode	7									
G5	gpmc_ncs5	0	O	H	H	7	VDDS_MEM	Yes	4	PU/ PD	LVC MOS
	sys_ndmareq2	1	I								
	mcbasp4_dr	2	I								
	gpt10_pwm_evt	3	IO								
	gpio_56	4	IO								
	safe_mode	7									
F3	gpmc_ncs6	0	O	H	H	7	VDDS_MEM	Yes	4	PU/ PD	LVC MOS
	sys_ndmareq3	1	I								
	mcbasp4_dx	2	IO								
	gpt11_pwm_evt	3	IO								
	gpio_57	4	IO								
	safe_mode	7									
G4	gpmc_ncs7	0	O	H	H	7	VDDS_MEM	Yes	4	PU/ PD	LVC MOS
	gpmc_io_dir	1	O								
	mcbasp4_fsx	2	IO								
	gpt8_pwm_evt	3	IO								
	gpio_58	4	IO								
	safe_mode	7									
W2	gpmc_clk	0	O	L	0	0	VDDS_MEM	Yes	4	PU/ PD	LVC MOS
	gpio_59	4	IO								
	safe_mode	7									
F1	gpmc_nadv_ale	0	O	0	0	0	VDDS_MEM	No	4	NA	LVC MOS
F2	gpmc_noe	0	O	1	1	0	VDDS_MEM	No	4	NA	LVC MOS
G3	gpmc_nwe	0	O	1	1	0	VDDS_MEM	No	4	NA	LVC MOS

PRODUCT PREVIEW

Table 2-2. Ball Characteristics (CUS Pkg.)⁽¹⁾ (continued)

BALL BOTTOM [1]	PIN NAME [3]	MODE [4]	TYPE [5]	BALL RESET STATE [6]	BALL RESET REL. STATE [7]	RESET REL. MODE [8]	POWER [9]	HYS [10]	BUFFER STRENGTH (mA) [11]	PULL U/D TYPE [12]	IO CELL [13]
K5	gpmc_nbe0_cle	0	O	L	0	0	VDDS_MEM	Yes	4	PU/ PD	LVC MOS
	gpio_60	4	IO								
	safe_mode	7									
L1	gpmc_nbe1	0	O	L	L	7	VDDS_MEM	Yes	4	PU/ PD	LVC MOS
	gpio_61	4	IO								
	safe_mode	7									
E1	gpmc_nwp	0	O	L	0	0	VDDS_MEM	Yes	4	PU/ PD	LVC MOS
	gpio_62	4	IO								
	safe_mode	7									
C1	gpmc_wait0	0	I	H	H	0	VDDS_MEM	Yes	NA	PU/ PD	LVC MOS
C2	gpmc_wait3	0	I	H	H	7	VDDS_MEM	Yes	4	PU/ PD	LVC MOS
	sys_ndmareq1	1	I								
	gpio_65	4	IO								
	safe_mode	7									
G22	dss_pclk	0	O	H	H	7	VDDS	Yes	4	PU/ PD	LVC MOS
	gpio_66	4	IO								
	safe_mode	7									
E22	dss_hsync	0	O	H	H	7	VDDS	Yes	4	PU/ PD	LVC MOS
	gpio_67	4	IO								
	safe_mode	7									
F22	dss_vsync	0	O	H	H	7	VDDS	Yes	4	PU/ PD	LVC MOS
	gpio_68	4	IO								
	safe_mode	7									
J21	dss_acbias	0	O	L	L	7	VDDS	Yes	8	PU/ PD	LVC MOS
	gpio_69	4	IO								
	safe_mode	7									
AC19	dss_data0	0	IO	L	L	7	VDDS	No	4	PU/ PD	LVDS/CMOS
	uart1_cts	2	I								
	gpio_70	4	IO								
	safe_mode	7									
AB19	dss_data1	0	IO	L	L	7	VDDS	No	4	PU/ PD	LVDS/CMOS
	uart1_rts	2	O								
	gpio_71	4	IO								
	safe_mode	7									
AD20	dss_data2	0	IO	L	L	7	VDDS	No	4	PU/ PD	LVDS/CMOS
	gpio_72	4	IO								
	safe_mode	7									
AC20	dss_data3	0	IO	L	L	7	VDDS	No	4	PU/ PD	LVDS/CMOS
	gpio_73	4	IO								
	safe_mode	7									

PRODUCT PREVIEW

Table 2-2. Ball Characteristics (CUS Pkg.)⁽¹⁾ (continued)

BALL BOTTOM [1]	PIN NAME [3]	MODE [4]	TYPE [5]	BALL RESET STATE [6]	BALL RESET REL. STATE [7]	RESET REL. MODE [8]	POWER [9]	HYS [10]	BUFFER STRENGTH (mA) [11]	PULL U/D TYPE [12]	IO CELL [13]
AD21	dss_data4	0	IO	L	L	7	VDDS	No	4	PU/ PD	LVDS/ CMOS
	uart3_rx_ irrx	2	I								
	gpio_74	4	IO								
	safe_mode	7									
AC21	dss_data5	0	IO	L	L	7	VDDS	No	4	PU/ PD	LVDS/ CMOS
	uart3_tx_ irtx	2	O								
	gpio_75	4	IO								
	safe_mode	7									
D24	dss_data6	0	IO	L	L	7	VDDS	Yes	8	PU/ PD	LVCMOS
	uart1_tx	2	O								
	gpio_76	4	IO								
	safe_mode	7									
E23	dss_data7	0	IO	L	L	7	VDDS	Yes	8	PU/ PD	LVCMOS
	uart1_rx	2	I								
	gpio_77	4	IO								
	safe_mode	7									
E24	dss_data8	0	IO	L	L	7	VDDS	Yes	8	PU/ PD	LVCMOS
	gpio_78	4	IO								
	safe_mode	7									
F23	dss_data9	0	IO	L	L	7	VDDS	Yes	8	PU/ PD	LVCMOS
	gpio_79	4	IO								
	safe_mode	7									
AC22	dss_data10	0	IO	L	L	7	VDDS	NA	4	PU/ PD	LVDS/ CMOS
	gpio_80	4	IO								
	safe_mode	7									
AC23	dss_data11	0	IO	L	L	7	VDDS	NA	4	PU/ PD	LVDS/ CMOS
	gpio_81	4	IO								
	safe_mode	7									
AB22	dss_data12	0	IO	L	L	7	VDDS	NA	4	PU/ PD	LVDS/ CMOS
	gpio_82	4	IO								
	safe_mode	7									
Y22	dss_data13	0	IO	L	L	7	VDDS	NA	4	PU/ PD	LVDS/ CMOS
	gpio_83	4	IO								
	safe_mode	7									
W22	dss_data14	0	IO	L	L	7	VDDS	NA	4	PU/ PD	LVDS/ CMOS
	gpio_84	4	IO								
	safe_mode	7									

PRODUCT PREVIEW

Table 2-2. Ball Characteristics (CUS Pkg.)⁽¹⁾ (continued)

BALL BOTTOM [1]	PIN NAME [3]	MODE [4]	TYPE [5]	BALL RESET STATE [6]	BALL RESET REL. STATE [7]	RESET REL. MODE [8]	POWER [9]	HYS [10]	BUFFER STRENGTH (mA) [11]	PULL U/D TYPE [12]	IO CELL [13]
V22	dss_data15	0	IO	L	L	7	VDDS	NA	4	PU/ PD	LVDS/ CMOS
	gpio_85	4	IO								
	safe_mode	7									
J22	dss_data16	0	IO	L	L	7	VDDS	Yes	8	PU/ PD	LVCMOS
	gpio_86	4	IO								
	safe_mode	7									
G23	dss_data17	0	IO	L	L	7	VDDS	Yes	8	PU/ PD	LVCMOS
	gpio_87	4	IO								
	safe_mode	7									
G24	dss_data18	0	IO	L	L	7	VDDS	Yes	8	PU/ PD	LVCMOS
	mcspi3_clk	2	IO								
	dss_data0	3	IO								
	gpio_88	4	IO								
	safe_mode	7									
H23	dss_data19	0	IO	L	L	7	VDDS	Yes	8	PU/ PD	LVCMOS
	mcspi3_simo	2	IO								
	dss_data1	3	IO								
	gpio_89	4	IO								
	safe_mode	7									
D23	dss_data20	0	O	H	H	7	VDDS	Yes	4	PU/ PD	LVCMOS
	mcspi3_somi	2	IO								
	dss_data2	3	IO								
	gpio_90	4	IO								
	safe_mode	7									
K22	dss_data21	0	O	L	L	7	VDDS	Yes	8	PU/ PD	LVCMOS
	mcspi3_cs0	2	IO								
	dss_data3	3	IO								
	gpio_91	4	IO								
	safe_mode	7									
V21	dss_data22	0	O	L	L	7	VDDS	NA	4	PU/ PD	LVDS/ CMOS
	mcspi3_cs1	2	O								
	dss_data4	3	IO								
	gpio_92	4	IO								
	safe_mode	7									
W21	dss_data23	0	O	L	L	7	VDDS	NA	4	PU/ PD	LVDS/ CMOS
	dss_data5	3	IO								
	gpio_93	4	IO								
	safe_mode	7									
AA23	tv_out2	0	O	Z	0	0	VDDADAC		8	NA	10-bit DAC
AB24	tv_out1	0	O	Z	0	0	VDDADAC		8	NA	10-bit DAC
AB23	tv_vfb1	0	O	Z	NA	0	VDDADAC			NA	10-bit DAC

PRODUCT PREVIEW

Table 2-2. Ball Characteristics (CUS Pkg.)⁽¹⁾ (continued)

BALL BOTTOM [1]	PIN NAME [3]	MODE [4]	TYPE [5]	BALL RESET STATE [6]	BALL RESET REL. STATE [7]	RESET REL. MODE [8]	POWER [9]	HYS [10]	BUFFER STRENGTH (mA) [11]	PULL U/D TYPE [12]	IO CELL [13]
Y23	tv_vfb2	0	O	Z	NA	0	VDDADAC			NA	10-bit DAC
Y24	tv_vref	0	I	Z	NA	0	VDDADAC			NA	10-bit DAC
A22	cam_hs	0	IO	L	L	7	VDDDS	Yes	4	PU/ PD	LVCMOS
	gpio_94	4	IO								
	safe_mode	7									
E18	cam_vs	0	IO	L	L	7	VDDDS	Yes	4	PU/ PD	LVCMOS
	gpio_95	4	IO								
	safe_mode	7									
B22	cam_xclka	0	O	L	L	7	VDDDS	Yes	4	PU/ PD	LVCMOS
	gpio_96	4	IO								
	safe_mode	7									
J19	cam_pclk	0	I	L	L	7	VDDDS	Yes	4	PU/ PD	LVCMOS
	gpio_97	4	IO								
	safe_mode	7									
H24	cam_fld	0	IO	L	L	7	VDDDS	Yes	4	PU/ PD	LVCMOS
	cam_global_reset	2	IO								
	gpio_98	4	IO								
	safe_mode	7									
AB18	cam_d0	0	I	L	L	7	VDDDS	Yes	4	PD	LVDS/CMOS
	gpio_99	4	I								
	safe_mode	7									
AC18	cam_d1	0	I	L	L	7	VDDDS	Yes	4	PD	LVDS/CMOS
	gpio_100	4	I								
	safe_mode	7									
G19	cam_d2	0	I	L	L	7	VDDDS	Yes	4	PU/ PD	LVCMOS
	gpio_101	4	IO								
	safe_mode	7									
F19	cam_d3	0	I	L	L	7	VDDDS	Yes	4	PU/ PD	LVCMOS
	gpio_102	4	IO								
	safe_mode	7									
G20	cam_d4	0	I	L	L	7	VDDDS	Yes	4	PU/ PD	LVCMOS
	gpio_103	4	IO								
	safe_mode	7									
B21	cam_d5	0	I	L	L	7	VDDDS	Yes	4	PU/ PD	LVCMOS
	gpio_104	4	IO								
	safe_mode	7									
L24	cam_d6	0	I	L	L	7	VDDDS	NA	4	PD	LVDS/CMOS
	gpio_105	4	IO								
	safe_mode	7									
K24	cam_d7	0	I	L	L	7	VDDDS	NA	4	PD	LVDS/CMOS
	gpio_106	4	IO								
	safe_mode	7									

PRODUCT PREVIEW

Table 2-2. Ball Characteristics (CUS Pkg.)⁽¹⁾ (continued)

BALL BOTTOM [1]	PIN NAME [3]	MODE [4]	TYPE [5]	BALL RESET STATE [6]	BALL RESET REL. STATE [7]	RESET REL. MODE [8]	POWER [9]	HYS [10]	BUFFER STRENGTH (mA) [11]	PULL U/D TYPE [12]	IO CELL [13]
J23	cam_d8	0	I	L	L	7	VDDS	NA	4	PD	LVDS/CMOS
	gpio_107	4	IO								
	safe_mode	7									
K23	cam_d9	0	I	L	L	7	VDDS	NA	4	PD	LVDS/CMOS
	gpio_108	4	IO								
	safe_mode	7									
F21	cam_d10	0	I	L	L	7	VDDS	Yes	4	PU/ PD	LVCMOS
	gpio_109	4	IO								
	safe_mode	7									
G21	cam_d11	0	I	L	L	7	VDDS	Yes	4	PU/ PD	LVCMOS
	gpio_110	4	IO								
	safe_mode	7									
C22	cam_xclkb	0	O	L	L	7	VDDS	Yes	4	PU/ PD	LVCMOS
	gpio_111	4	IO								
	safe_mode	7									
F18	cam_wen	0	I	L	L	7	VDDS	Yes	4	PU/ PD	LVCMOS
	cam_shutter	2	O								
	gpio_167	4	IO								
	safe_mode	7									
J20	cam_strobe	0	O	L	L	7	VDDS	Yes	4	PU/ PD	LVCMOS
	gpio_126	4	IO								
	safe_mode	7									
V20	mcbasp2_fsx	0	IO	PGM	L	7	VDDS	Yes	4 ⁽²⁾	PU/ PD	LVCMOS
	gpio_116	4	IO								
	safe_mode	7									
T21	mcbasp2_clkx	0	IO	PGM	L	7	VDDS	Yes	4 ⁽²⁾	PU/ PD	LVCMOS
	gpio_117	4	IO								
	safe_mode	7									
V19	mcbasp2_dr	0	I	PGM	L	7	VDDS	Yes	4 ⁽²⁾	PU/ PD	LVCMOS
	gpio_118	4	IO								
	safe_mode	7									
R20	mcbasp2_dx	0	IO	PGM	L	7	VDDS	Yes	4 ⁽²⁾	PU/ PD	LVCMOS
	gpio_119	4	IO								
	safe_mode	7									
M23	mmc1_clk	0	O	L	L	7	MMC1_VDDS	Yes	8	PU/ PD	LVCMOS
	ms_clk	1	O								
	gpio_120	4	IO								
	safe_mode	7									
L23	mmc1_cmd	0	IO	L	L	7	MMC1_VDDS	Yes	8	PU/ PD	LVCMOS
	ms_bs	1	O								
	gpio_121	4	IO								
	safe_mode	7									

PRODUCT PREVIEW

Table 2-2. Ball Characteristics (CUS Pkg.)⁽¹⁾ (continued)

BALL BOTTOM [1]	PIN NAME [3]	MODE [4]	TYPE [5]	BALL RESET STATE [6]	BALL RESET REL. STATE [7]	RESET REL. MODE [8]	POWER [9]	HYS [10]	BUFFER STRENGTH (mA) [11]	PULL U/D TYPE [12]	IO CELL [13]
M22	mmc1_dat0	0	IO	L	L	7	MMC1_VDDS	Yes	8	PU/ PD	LVCMOS
	ms_dat0	1	IO								
	gpio_122	4	IO								
	safe_mode	7									
M21	mmc1_dat1	0	IO	L	L	7	MMC1_VDDS	Yes	8	PU/ PD	LVCMOS
	ms_dat1	1	IO								
	gpio_123	4	IO								
	safe_mode	7									
M20	mmc1_dat2	0	IO	L	L	7	MMC1_VDDS	Yes	8	PU/ PD	LVCMOS
	ms_dat2	1	IO								
	gpio_124	4	IO								
	safe_mode	7									
N23	mmc1_dat3	0	IO	L	L	7	MMC1_VDDS	Yes	8	PU/ PD	LVCMOS
	ms_dat3	1	IO								
	gpio_125	4	IO								
	safe_mode	7									
N22	mmc1_dat4	0	IO	L	L	7	VDDS	No	8	PD	LVCMOS
	gpio_126	4	IO								
	safe_mode	7									
N21	mmc1_dat5	0	IO	L	L	7	VDDS	No	8	PD	LVCMOS
	gpio_127	4	IO								
	safe_mode	7									
N20	mmc1_dat6	0	IO	L	L	7	VDDS	No	8	PD	LVCMOS
	gpio_128	4	IO								
	safe_mode	7									
P24	mmc1_dat7	0	IO	L	L	7	VDDS	No	8	PD	LVCMOS
	gpio_129	4	IO								
	safe_mode	7									
Y1	mmc2_clk	0	O	L	L	7	VDDS	Yes	4	PU/ PD	LVCMOS
	mcspi3_clk	1	IO								
	gpio_130	4	IO								
	safe_mode	7									
AB5	mmc2_cmd	0	IO	H	H	7	VDDS	Yes	4	PU/ PD	LVCMOS
	mcspi3_simo	1	IO								
	gpio_131	4	IO								
	safe_mode	7									
AB3	mmc2_dat0	0	IO	H	H	7	VDDS	Yes	4	PU/ PD	LVCMOS
	mcspi3_somi	1	IO								
	gpio_132	4	IO								
	safe_mode	7									
Y3	mmc2_dat1	0	IO	H	H	7	VDDS	Yes	4	PU/ PD	LVCMOS
	gpio_133	4	IO								
	safe_mode	7									

PRODUCT PREVIEW

Table 2-2. Ball Characteristics (CUS Pkg.)⁽¹⁾ (continued)

BALL BOTTOM [1]	PIN NAME [3]	MODE [4]	TYPE [5]	BALL RESET STATE [6]	BALL RESET REL. STATE [7]	RESET REL. MODE [8]	POWER [9]	HYS [10]	BUFFER STRENGTH (mA) [11]	PULL U/D TYPE [12]	IO CELL [13]
W3	mmc2_dat2	0	IO	H	H	7	VDDS	Yes	4	PU/ PD	LVCMOS
	mcspi3_cs1	1	O								
	gpio_134	4	IO								
	safe_mode	7									
V3	mmc2_dat3	0	IO	H	H	7	VDDS	Yes	4	PU/ PD	LVCMOS
	mcspi3_cs0	1	IO								
	gpio_135	4	IO								
	safe_mode	7									
AB2	mmc2_dat4	0	IO	L	L	7	VDDS	Yes	4	PU/ PD	LVCMOS
	mmc2_dir_d at0	1	O								
	mmc3_dat0	3	IO								
	gpio_136	4	IO								
	safe_mode	7									
AA2	mmc2_dat5	0	IO	L	L	7	VDDS	Yes	4	PU/ PD	LVCMOS
	mmc2_dir_d at1	1	O								
	cam_global_reset	2	IO								
	mmc3_dat1	3	IO								
	gpio_137	4	IO								
	safe_mode	7									
Y2	mmc2_dat6	0	IO	L	L	7	VDDS	Yes	4	PU/ PD	LVCMOS
	mmc2_dir_cmd	1	O								
	cam_shutter	2	O								
	mmc3_dat2	3	IO								
	gpio_138	4	IO								
	safe_mode	7									
AA1	mmc2_dat7	0	IO	L	L	7	VDDS	Yes	4	PU/ PD	LVCMOS
	mmc2_clkln	1	I								
	mmc3_dat3	3	IO								
	gpio_139	4	IO								
	safe_mode	7									
V6	mcbasp3_dx	0	IO	L	L	7	VDDS	Yes	4	PU/ PD	LVCMOS
	uart2_cts	1	I								
	gpio_140	4	IO								
	safe_mode	7									
V5	mcbasp3_dr	0	I	L	L	7	VDDS	Yes	4	PU/ PD	LVCMOS
	uart2_rts	1	O								
	gpio_141	4	IO								
	safe_mode	7									

PRODUCT PREVIEW

Table 2-2. Ball Characteristics (CUS Pkg.)⁽¹⁾ (continued)

BALL BOTTOM [1]	PIN NAME [3]	MODE [4]	TYPE [5]	BALL RESET STATE [6]	BALL RESET REL. STATE [7]	RESET REL. MODE [8]	POWER [9]	HYS [10]	BUFFER STRENGTH (mA) [11]	PULL U/D TYPE [12]	IO CELL [13]
W4	mcbasp3_clkx	0	IO	L	L	7	VDDS	Yes	4	PU/ PD	LVCMOS
	uart2_tx	1	O								
	gpio_142	4	IO								
	safe_mode	7									
V4	mcbasp3_fsx	0	IO	L	L	7	VDDS	Yes	4	PU/ PD	LVCMOS
	uart2_rx	1	I								
	gpio_143	4	IO								
	safe_mode	7									
W7	uart1_tx	0	O	L	L	7	VDDS	Yes	4	PU/ PD	LVCMOS
	gpio_148	4	IO								
	safe_mode	7									
W6	uart1_rts	0	O	L	L	7	VDDS	Yes	4	PU/ PD	LVCMOS
	gpio_149	4	IO								
	safe_mode	7									
AC2	uart1_cts	0	I	L	L	7	VDDS	Yes	4	PU/ PD	LVCMOS
	gpio_150	4	IO								
	safe_mode	7									
V7	uart1_rx	0	I	L	L	7	VDDS	Yes	4	PU/ PD	LVCMOS
	mcbasp1_clkr	2	IO								
	mcspi4_clk	3	IO								
	gpio_151	4	IO								
	safe_mode	7									
W19	mcbasp1_clkr	0	IO	L	L	7	VDDS	Yes	4	PU/ PD	LVCMOS
	mcspi4_clk	1	IO								
	gpio_156	4	IO								
	safe_mode	7									
AB20	mcbasp1_fsr	0	IO	L	L	7	VDDS	Yes	4	PU/ PD	LVCMOS
	adpll2d_dithering_en1	1	I								
	cam_global_reset	2	IO								
	gpio_157	4	IO								
	safe_mode	7									
W18	mcbasp1_dx	0	IO	L	L	7	VDDS	Yes	4	PU/ PD	LVCMOS
	mcspi4_simo	1	IO								
	mcbasp3_dx	2	IO								
	gpio_158	4	IO								
	safe_mode	7									
Y18	mcbasp1_dr	0	I	L	L	7	VDDS	Yes	4	PU/ PD	LVCMOS
	mcspi4_somi	1	IO								
	mcbasp3_dr	2	O								

PRODUCT PREVIEW

Table 2-2. Ball Characteristics (CUS Pkg.)⁽¹⁾ (continued)

BALL BOTTOM [1]	PIN NAME [3]	MODE [4]	TYPE [5]	BALL RESET STATE [6]	BALL RESET REL. STATE [7]	RESET REL. MODE [8]	POWER [9]	HYS [10]	BUFFER STRENGTH (mA) [11]	PULL U/D TYPE [12]	IO CELL [13]
	gpio_159	4	IO								
	safe_mode	7									
AA18	mcbasp_clks	0	I	L	L	7	VDDS	Yes	4	PU/ PD	LVC MOS
	cam_shutter	2	O								
	gpio_160	4	IO								
	uart1_cts	5	I								
	safe_mode	7									
AA19	mcbasp1_fsx	0	IO	L	L	7	VDDS	Yes	4	PU/ PD	LVC MOS
	mcspi4_cs0	1	IO								
	mcbasp3_fsx	2	IO								
	gpio_161	4	IO								
	safe_mode	7									
V18	mcbasp1_clkx	0	IO	L	L	7	VDDS	Yes	4	PU/ PD	LVC MOS
	mcbasp3_clkx	2	IO								
	gpio_162	4	IO								
	safe_mode	7									
A23	uart3_cts_rctx	0	IO	H	H	7	VDDS	Yes	4	PU/ PD	LVC MOS
	gpio_163	4	IO								
	safe_mode	7									
B23	uart3_rts_sd	0	O	H	H	7	VDDS	Yes	4	PU/ PD	LVC MOS
	gpio_164	4	IO								
	safe_mode	7									
B24	uart3_rx_irrx	0	I	H	H	7	VDDS	Yes	4	PU/ PD	LVC MOS
	gpio_165	4	IO								
	safe_mode	7									
C23	uart3_tx_irtx	0	O	H	H	7	VDDS	Yes	4	PU/ PD	LVC MOS
	gpio_166	4	IO								
	safe_mode	7									
R21	hsusb0_clk	0	I	L	L	7	VDDS	Yes	4	PU/ PD	LVC MOS
	gpio_120	4	IO								
	safe_mode	7									
R23	hsusb0_stp	0	O	H	H	7	VDDS	Yes	4	PU/ PD	LVC MOS
	gpio_121	4	IO								
	safe_mode	7									
P23	hsusb0_dir	0	I	L	L	7	VDDS	Yes	4	PU/ PD	LVC MOS
	gpio_122	4	IO								
	safe_mode	7									
R22	hsusb0_nxt	0	I	L	L	7	VDDS	Yes	4	PU/ PD	LVC MOS
	gpio_124	4	IO								

PRODUCT PREVIEW

Table 2-2. Ball Characteristics (CUS Pkg.)⁽¹⁾ (continued)

BALL BOTTOM [1]	PIN NAME [3]	MODE [4]	TYPE [5]	BALL RESET STATE [6]	BALL RESET REL. STATE [7]	RESET REL. MODE [8]	POWER [9]	HYS [10]	BUFFER STRENGTH (mA) [11]	PULL U/D TYPE [12]	IO CELL [13]
	safe_mode	7									
T24	hsusb0_data0	0	IO	L	L	7	VDDS	Yes	4	PU/ PD	LVC MOS
	uart3_tx_irtx	2	O								
	gpio_125	4	IO								
	safe_mode	7									
T23	hsusb0_data1	0	IO	L	L	7	VDDS	Yes	4	PU/ PD	LVC MOS
	uart3_rx_irrx	2	I								
	gpio_130	4	IO								
	safe_mode	7									
U24	hsusb0_data2	0	IO	L	L	7	VDDS	Yes	4	PU/ PD	LVC MOS
	uart3_rts_sd	2	O								
	gpio_131	4	IO								
	safe_mode	7									
U23	hsusb0_data3	0	IO	L	L	7	VDDS	Yes	4	PU/ PD	LVC MOS
	uart3_cts_rctx	2	IO								
	gpio_169	4	IO								
	safe_mode	7									
W24	hsusb0_data4	0	IO	L	L	7	VDDS	Yes	4	PU/ PD	LVC MOS
	gpio_188	4	IO								
	safe_mode	7									
V23	hsusb0_data5	0	IO	L	L	7	VDDS	Yes	4	PU/ PD	LVC MOS
	gpio_189	4	IO								
	safe_mode	7									
W23	hsusb0_data6	0	IO	L	L	7	VDDS	Yes	4	PU/ PD	LVC MOS
	gpio_190	4	IO								
	safe_mode	7									
T22	hsusb0_data7	0	IO	L	L	7	VDDS	Yes	4	PU/ PD	LVC MOS
	gpio_191	4	IO								
	safe_mode	7									
K20	i2c1_scl	0	IOD	H	H	0	VDDS	Yes	4	PU/ PD	Open Drain
K21	i2c1_sda	0	IOD	H	H	0	VDDS	Yes	4	PU/ PD	Open Drain
AC15	i2c2_scl	0	IOD	H	H	7	VDDS	Yes	4	PU/ PD	Open Drain
	gpio_168	4	IO								
	safe_mode	7									
AC14	i2c2_sda	0	IOD	H	H	7	VDDS	Yes	4	PU/ PD	Open Drain
	gpio_183	4	IO								

PRODUCT PREVIEW

Table 2-2. Ball Characteristics (CUS Pkg.)⁽¹⁾ (continued)

BALL BOTTOM [1]	PIN NAME [3]	MODE [4]	TYPE [5]	BALL RESET STATE [6]	BALL RESET REL. STATE [7]	RESET REL. MODE [8]	POWER [9]	HYS [10]	BUFFER STRENGTH (mA) [11]	PULL U/D TYPE [12]	IO CELL [13]
	safe_mode	7									
AC13	i2c3_scl	0	IOD	H	H	7	VDDS	Yes	4	PU/ PD	Open Drain
	gpio_184	4	IO								
	safe_mode	7									
AC12	i2c3_sda	0	IOD	H	H	7	VDDS	Yes	4	PU/ PD	Open Drain
	gpio_185	4	IO								
	safe_mode	7									
Y16	i2c4_scl	0	IOD	H	H	0	VDDS	Yes	4	PU/ PD	Open Drain
	sys_nvmode1	1	O								
	safe_mode	7									
Y15	i2c4_sda	0	IOD	H	H	0	VDDS	Yes	4	PU/ PD	Open Drain
	sys_nvmode2	1	O								
	safe_mode	7									
A24	hdq_sio	0	IOD	H	H	7	VDDS	Yes	4	PU/ PD	LVCMOS
	sys_altclk	1	I								
	i2c2_sccb2	2	O								
	i2c3_sccb2	3	O								
	gpio_170	4	IO								
	safe_mode	7									
T5	mcspi1_clk	0	IO	PGM	L	7	VDDS	Yes	4 ⁽²⁾	PU/ PD	LVCMOS
	mmc2_dat4	1	IO								
	gpio_171	4	IO								
	safe_mode	7									
R4	mcspi1_simo	0	IO	PGM	L	7	VDDS	Yes	4 ⁽²⁾	PU/ PD	LVCMOS
	mmc2_dat5	1	IO								
	gpio_172	4	IO								
	safe_mode	7									
T4	mcspi1_somi	0	IO	PGM	L	7	VDDS	Yes	4 ⁽²⁾	PU/ PD	LVCMOS
	mmc2_dat6	1	IO								
	gpio_173	4	IO								
	safe_mode	7									
T6	mcspi1_cs0	0	IO	PGM	H	7	VDDS	Yes	4 ⁽²⁾	PU/ PD	LVCMOS
	mmc2_dat7	1	IO								
	gpio_174	4	IO								
	safe_mode	7									
R5	mcspi1_cs3	0	O	H	H	7	VDDS	Yes	4	PU/ PD	LVCMOS
	hsusb2_tll_data2	2	IO								
	hsusb2_data2	3	IO								
	gpio_177	4	IO								
	mm2_txdat	5	IO								

PRODUCT PREVIEW

Table 2-2. Ball Characteristics (CUS Pkg.)⁽¹⁾ (continued)

BALL BOTTOM [1]	PIN NAME [3]	MODE [4]	TYPE [5]	BALL RESET STATE [6]	BALL RESET REL. STATE [7]	RESET REL. MODE [8]	POWER [9]	HYS [10]	BUFFER STRENGTH (mA) [11]	PULL U/D TYPE [12]	IO CELL [13]
	safe_mode	7									
N5	mcspi2_clk	0	IO	L	L	7	VDDS	Yes	4	PU/ PD	LVC MOS
	hsusb2_tll_data7	2	IO								
	hsusb2_data7	3	O								
	gpio_178	4	IO								
	safe_mode	7									
N4	mcspi2_simo	0	IO	L	L	7	VDDS	Yes	4	PU/ PD	LVC MOS
	gpt9_pwm_evt	1	IO								
	hsusb2_tll_data4	2	IO								
	hsusb2_data4	3	I								
	gpio_179	4	IO								
	safe_mode	7									
N3	mcspi2_somi	0	IO	L	L	7	VDDS	Yes	4	PU/ PD	LVC MOS
	gpt10_pwm_evt	1	IO								
	hsusb2_tll_data5	2	IO								
	hsusb2_data5	3	O								
	gpio_180	4	IO								
	safe_mode	7									
M5	mcspi2_cs0	0	IO	H	H	7	VDDS	Yes	4	PU/ PD	LVC MOS
	gpt11_pwm_evt	1	IO								
	hsusb2_tll_data6	2	IO								
	hsusb2_data6	3	O								
	gpio_181	4	IO								
	safe_mode	7									
M4	mcspi2_cs1	0	O	L	L	7	VDDS	Yes	4	PU/ PD	LVC MOS
	gpt8_pwm_evt	1	IO								
	hsusb2_tll_data3	2	IO								
	hsusb2_data3	3	IO								
	gpio_182	4	IO								
	mm2_txen_n	5	IO								
	safe_mode	7									
AA16	sys_32k	0	I	Z	I	NA	VDDS	Yes	NA	NA	LVC MOS
AD15	sys_xtalin	0	I	Z	I	NA	VDDS	Yes	NA	NA	LVC MOS

PRODUCT PREVIEW

Table 2-2. Ball Characteristics (CUS Pkg.)⁽¹⁾ (continued)

BALL BOTTOM [1]	PIN NAME [3]	MODE [4]	TYPE [5]	BALL RESET STATE [6]	BALL RESET REL. STATE [7]	RESET REL. MODE [8]	POWER [9]	HYS [10]	BUFFER STRENGTH (mA) [11]	PULL U/D TYPE [12]	IO CELL [13]
AD14	sys_xtalout	0	O	Z	O	NA	VDDS	Yes		NA	LVC MOS
Y13	sys_clkreq	0	IO	0	1	0	VDDS	Yes	4	PU/ PD	LVC MOS
	gpio_1	4	IO								
	safe_mode	7									
W16	sys_nirq	0	I	H	H	7	VDDS	Yes	4	PU/ PD	LVC MOS
	gpio_0	4	IO								
	safe_mode	7									
AA10	sys_nrespwrn	0	I	Z	I	NA	VDDS	Yes	NA	NA	LVC MOS
Y10	sys_nreswarm	0	IOD	0	1 (PU)	0	VDDS	Yes	4	PU/ PD	LVC MOS
	gpio_30	4	IO								
	safe_mode	7									
AB12	sys_boot0	0	I	Z	Z	0	VDDS	Yes	4	PU/ PD	LVC MOS
	gpio_2	4	IO								
	safe_mode	7									
AC16	sys_boot1	0	I	Z	Z	0	VDDS	Yes	4	PU/ PD	LVC MOS
	gpio_3	4	IO								
	safe_mode	7									
AD17	sys_boot2	0	I	Z	Z	0	VDDS	Yes	4	PU/ PD	LVC MOS
	gpio_4	4	IO								
	safe_mode	7									
AD18	sys_boot3	0	I	Z	Z	0	VDDS	Yes	4	PU/ PD	LVC MOS
	gpio_5	4	IO								
	safe_mode	7									
AC17	sys_boot4	0	I	Z	Z	0	VDDS	Yes	4	PU/ PD	LVC MOS
	mmc2_dir_d at2	1	O								
	gpio_6	4	IO								
	safe_mode	7									
AB16	sys_boot5	0	I	Z	Z	0	VDDS	Yes	4	PU/ PD	LVC MOS
	mmc2_dir_d at3	1	O								
	gpio_7	4	IO								
	safe_mode	7									
AA15	sys_boot6	0	I	Z	Z	0	VDDS	Yes	4	PU/ PD	LVC MOS
	gpio_8	4	IO								
	safe_mode	7									
AD23	sys_off_mode	0	O	0	L	7	VDDS	Yes	4	PU/ PD	LVC MOS
	gpio_9	4	IO								
	safe_mode	7									
Y7	sys_clkout1	0	O	L	L	7	VDDS	Yes	4	PU/ PD	LVC MOS
	gpio_10	4	IO								
	safe_mode	7									

PRODUCT PREVIEW

Table 2-2. Ball Characteristics (CUS Pkg.)⁽¹⁾ (continued)

BALL BOTTOM [1]	PIN NAME [3]	MODE [4]	TYPE [5]	BALL RESET STATE [6]	BALL RESET REL. STATE [7]	RESET REL. MODE [8]	POWER [9]	HYS [10]	BUFFER STRENGTH (mA) [11]	PULL U/D TYPE [12]	IO CELL [13]
AA6	sys_clkout2	0	O	L	L	7	VDDS	Yes	4	PU/ PD	LVCMOS
	gpio_186	4	IO								
	safe_mode	7									
A1	sys_ipmcsws	0	AI	Z	AI	NA	VDDS	NA	NA	NA	Analog
A2	sys_opmcsws	0	AO	0	AO	NA	VDDS	No	NA	NA	LVCMOS
AB7	jtag_ntrst	0	I	L	L	0	VDDS	Yes	NA	PU/ PD	LVCMOS
AB6	jtag_tck	0	I	L	L	0	VDDS	Yes	NA	PU/ PD	LVCMOS
AA7	jtag_rtck	0	O	L	0	0	VDDS	Yes	4	PU/ PD	LVCMOS
AA9	jtag_tms_tm_sc	0	IO	H	H	0	VDDS	Yes	4	PU/ PD	LVCMOS
AB10	jtag_tdi	0	I	H	H	0	VDDS	Yes	NA	PU/ PD	LVCMOS
AB9	jtag_tdo	0	O	L	Z	0	VDDS	Yes	4	PU/ PD	LVCMOS
AC24	jtag_emu0	0	IO	H	H	0	VDDS	Yes	4	PU/ PD	LVCMOS
	gpio_11	4	IO								
	safe_mode	7									
AD24	jtag_emu1	0	IO	H	H	0	VDDS	Yes	4	PU/ PD	LVCMOS
	gpio_31	4	IO								
	safe_mode	7									
AC1	etk_clk	0	O	H	H	4	VDDS	Yes	4	PU/ PD	LVCMOS
	mcbsp5_clkx	1	IO								
	mmc3_clk	2	O								
	hsusb1_stp	3	O								
	gpio_12	4	IO								
	mm1_rxdp	5	IO								
	hsusb1_tll_stp	6	I								
AD3	etk_ctl	0	O	H	H	4	VDDS	Yes	4	PU/ PD	LVCMOS
	mmc3_cmd	2	IO								
	hsusb1_clk	3	O								
	gpio_13	4	IO								
	hsusb1_tll_clk	6	O								
AD6	etk_d0	0	O	H	H	4	VDDS	Yes	4	PU/ PD	LVCMOS
	mcspi3_simo	1	IO								
	mmc3_dat4	2	IO								
	hsusb1_data0	3	IO								
	gpio_14	4	IO								
	mm1_rxcv	5	IO								
	hsusb1_tll_data0	6	IO								

PRODUCT PREVIEW

Table 2-2. Ball Characteristics (CUS Pkg.)⁽¹⁾ (continued)

BALL BOTTOM [1]	PIN NAME [3]	MODE [4]	TYPE [5]	BALL RESET STATE [6]	BALL RESET REL. STATE [7]	RESET REL. MODE [8]	POWER [9]	HYS [10]	BUFFER STRENGTH (mA) [11]	PULL U/D TYPE [12]	IO CELL [13]
AC6	etk_d1	0	O	H	H	4	VDDS	Yes	4	PU/ PD	LVCMOS
	mcspi3_somi	1	IO								
	hsusb1_data1	3	IO								
	gpio_15	4	IO								
	mm1_txse0	5	IO								
	hsusb1_tll_data1	6	IO								
AC7	etk_d2	0	O	H	H	4	VDDS	Yes	4	PU/ PD	LVCMOS
	mcspi3_cs0	1	IO								
	hsusb1_data2	3	IO								
	gpio_16	4	IO								
	mm1_txdat	5	IO								
	hsusb1_tll_data2	6	IO								
AD8	etk_d3	0	O	H	H	4	VDDS	Yes	4	PU/ PD	LVCMOS
	mcspi3_clk	1	IO								
	mmc3_dat3	2	IO								
	hsusb1_data7	3	IO								
	gpio_17	4	IO								
	hsusb1_tll_data7	6	IO								
AC5	etk_d4	0	O	L	L	4	VDDS	Yes	4	PU/ PD	LVCMOS
	mcbbsp5_dr	1	I								
	mmc3_dat0	2	IO								
	hsusb1_data4	3	IO								
	gpio_18	4	IO								
	hsusb1_tll_data4	6	IO								
AD2	etk_d5	0	O	L	L	4	VDDS	Yes	4	PU/ PD	LVCMOS
	mcbbsp5_fsx	1	IO								
	mmc3_dat1	2	IO								
	hsusb1_data5	3	IO								
	gpio_19	4	IO								
	hsusb1_tll_data5	6	IO								
AC8	etk_d6	0	O	L	L	4	VDDS	Yes	4	PU/ PD	LVCMOS
	mcbbsp5_dx	1	IO								
	mmc3_dat2	2	IO								
	hsusb1_data6	3	IO								
	gpio_20	4	IO								

PRODUCT PREVIEW

Table 2-2. Ball Characteristics (CUS Pkg.)⁽¹⁾ (continued)

BALL BOTTOM [1]	PIN NAME [3]	MODE [4]	TYPE [5]	BALL RESET STATE [6]	BALL RESET REL. STATE [7]	RESET REL. MODE [8]	POWER [9]	HYS [10]	BUFFER STRENGTH (mA) [11]	PULL U/D TYPE [12]	IO CELL [13]
	hsusb1_tll_data6	6	IO								
AD9	etk_d7	0	O	L	L	4	VDDS	Yes	4	PU/ PD	LVC MOS
	mcspi3_cs1	1	O								
	mmc3_dat7	2	IO								
	hsusb1_data3	3	IO								
	gpio_21	4	IO								
	mm1_txen_n	5	IO								
	hsusb1_tll_data3	6	IO								
AC4	etk_d8	0	O	L	L	4	VDDS	Yes	4	PU/ PD	LVC MOS
	sys_drm_msecure	1	O								
	mmc3_dat6	2	IO								
	hsusb1_dir	3	I								
	gpio_22	4	IO								
	hsusb1_tll_dir	6	O								
AD5	etk_d9	0	O	L	L	4	VDDS	Yes	4	PU/ PD	LVC MOS
	sys_secure_indicator	1	O								
	mmc3_dat5	2	IO								
	hsusb1_nxt	3	I								
	gpio_23	4	IO								
	mm1_rxdm	5	IO								
	hsusb1_tll_nxt	6	O								
AC3	etk_d10	0	O	L	L	4	VDDS	Yes	4	PU/ PD	LVC MOS
	uart1_rx	2	I								
	hsusb2_clk	3	O								
	gpio_24	4	IO								
	hsusb2_tll_clk	6	O								
AC9	etk_d11	0	O	L	L	4	VDDS	Yes	4	PU/ PD	LVC MOS
	hsusb2_stp	3	O								
	gpio_25	4	IO								
	mm2_rxdp	5	IO								
	hsusb2_tll_stp	6	I								
AC10	etk_d12	0	O	L	L	4	VDDS	Yes	4	PU/ PD	LVC MOS
	hsusb2_dir	3	I								
	gpio_26	4	IO								
	hsusb2_tll_dir	6	O								

PRODUCT PREVIEW

Table 2-2. Ball Characteristics (CUS Pkg.)⁽¹⁾ (continued)

BALL BOTTOM [1]	PIN NAME [3]	MODE [4]	TYPE [5]	BALL RESET STATE [6]	BALL RESET REL. STATE [7]	RESET REL. MODE [8]	POWER [9]	HYS [10]	BUFFER STRENGTH (mA) [11]	PULL U/D TYPE [12]	IO CELL [13]
AD11	etk_d13	0	O	L	L	4	VDDS	Yes	4	PU/ PD	LVCMOS
	hsusb2_nxt	3	I								
	gpio_27	4	IO								
	mm2_rxdm	5	IO								
	hsusb2_tll_nxt	6	O								
AC11	etk_d14	0	O	L	L	4	VDDS	Yes	4	PU/ PD	LVCMOS
	hsusb2_data0	3	IO								
	gpio_28	4	IO								
	mm2_rxcv	5	IO								
	hsusb2_tll_data0	6	IO								
AD12	etk_d15	0	O	L	L	4	VDDS	Yes	4	PU/ PD	LVCMOS
	hsusb2_data1	3	IO								
	gpio_29	4	IO								
	mm2_txse0	5	IO								
	hsusb2_tll_data1	6	IO								

(1) NA in this table stands for Not Applicable.

(2) The buffer strength of this IO cell is programmable (2, 4, 6, or 8 mA) according to the selected mode; the default value is described in the above table.

PRODUCT PREVIEW

2.3 Multiplexing Characteristics

Table 2-3 and Table 2-4 provide a description of the OMAP3515/03 multiplexing on the CBB and CUS packages, respectively.

Note: Table 2-3 and Table 2-4 do not take into account subsystem pin multiplexing options. Subsystem pin multiplexing options are described in Section 2.4, *Signal Description*.

Table 2-3. Multiplexing Characteristics (CBB Pkg.)⁽¹⁾

Ball Bottom	Ball Top	Mode 0	Mode 1	Mode 2	Mode 3	Mode 4	Mode 5	Mode 6	Mode 7
D6	J2	sdrc_d0	-	-	-	-	-	-	-
C6	J1	sdrc_d1	-	-	-	-	-	-	-
B6	G2	sdrc_d2	-	-	-	-	-	-	-
C8	G1	sdrc_d3	-	-	-	-	-	-	-
C9	F2	sdrc_d4	-	-	-	-	-	-	-
A7	F1	sdrc_d5	-	-	-	-	-	-	-
B9	D2	sdrc_d6	-	-	-	-	-	-	-
A9	D1	sdrc_d7	-	-	-	-	-	-	-
C14	B13	sdrc_d8	-	-	-	-	-	-	-
B14	A13	sdrc_d9	-	-	-	-	-	-	-
C15	B14	sdrc_d10	-	-	-	-	-	-	-
B16	A14	sdrc_d11	-	-	-	-	-	-	-
D17	B16	sdrc_d12	-	-	-	-	-	-	-
C17	A16	sdrc_d13	-	-	-	-	-	-	-
B17	B19	sdrc_d14	-	-	-	-	-	-	-
D18	A19	sdrc_d15	-	-	-	-	-	-	-
D11	B3	sdrc_d16	-	-	-	-	-	-	-
B10	A3	sdrc_d17	-	-	-	-	-	-	-
C11	B5	sdrc_d18	-	-	-	-	-	-	-
D12	A5	sdrc_d19	-	-	-	-	-	-	-
C12	B8	sdrc_d20	-	-	-	-	-	-	-
A11	A8	sdrc_d21	-	-	-	-	-	-	-
B13	B9	sdrc_d22	-	-	-	-	-	-	-
D14	A9	sdrc_d23	-	-	-	-	-	-	-
C18	B21	sdrc_d24	-	-	-	-	-	-	-
A19	A21	sdrc_d25	-	-	-	-	-	-	-
B19	D22	sdrc_d26	-	-	-	-	-	-	-
B20	D23	sdrc_d27	-	-	-	-	-	-	-
D20	E22	sdrc_d28	-	-	-	-	-	-	-
A21	E23	sdrc_d29	-	-	-	-	-	-	-
B21	G22	sdrc_d30	-	-	-	-	-	-	-
C21	G23	sdrc_d31	-	-	-	-	-	-	-
H9	AB21	sdrc_ba0	-	-	-	-	-	-	-
H10	AC21	sdrc_ba1	-	-	-	-	-	-	-
A4	N22	sdrc_a0	-	-	-	-	-	-	-
B4	N 23	sdrc_a1	-	-	-	-	-	-	-
B3	P22	sdrc_a2	-	-	-	-	-	-	-
C5	P23	sdrc_a3	-	-	-	-	-	-	-
C4	R22	sdrc_a4	-	-	-	-	-	-	-
D5	R23	sdrc_a5	-	-	-	-	-	-	-

PRODUCT PREVIEW

Table 2-3. Multiplexing Characteristics (CBB Pkg.)⁽¹⁾ (continued)

Ball Bottom	Ball Top	Mode 0	Mode 1	Mode 2	Mode 3	Mode 4	Mode 5	Mode 6	Mode 7
C3	T22	sdrc_a6	-	-	-	-	-	-	-
C2	T23	sdrc_a7	-	-	-	-	-	-	-
C1	U22	sdrc_a8	-	-	-	-	-	-	-
D4	U23	sdrc_a9	-	-	-	-	-	-	-
D3	V22	sdrc_a10	-	-	-	-	-	-	-
D2	V23	sdrc_a11	-	-	-	-	-	-	-
D1	W22	sdrc_a12	-	-	-	-	-	-	-
E2	W23	sdrc_a13	-	-	-	-	-	-	-
E1	Y22	sdrc_a14	-	-	-	-	-	-	-
H11	M22	sdrc_ncs0	-	-	-	-	-	-	-
H12	M23	sdrc_ncs1	-	-	-	-	-	-	-
A13	A11	sdrc_clk	-	-	-	-	-	-	-
A14	B11	sdrc_nclk	-	-	-	-	-	-	-
H16	J22	sdrc_cke0	-	-	-	-	-	-	safe_mode
H17	J23	sdrc_cke1	-	-	-	-	-	-	safe_mode
H14	L23	sdrc_nras	-	-	-	-	-	-	-
H13	L22	sdrc_ncas	-	-	-	-	-	-	-
H15	K23	sdrc_nwe	-	-	-	-	-	-	-
B7	C1	sdrc_dm0	-	-	-	-	-	-	-
A16	A17	sdrc_dm1	-	-	-	-	-	-	-
B11	A6	sdrc_dm2	-	-	-	-	-	-	-
C20	A20	sdrc_dm3	-	-	-	-	-	-	-
A6	C2	sdrc_dqs0	-	-	-	-	-	-	-
A17	B17	sdrc_dqs1	-	-	-	-	-	-	-
A10	B6	sdrc_dqs2	-	-	-	-	-	-	-
A20	B20	sdrc_dqs3	-	-	-	-	-	-	-
N4	AC15	gpmc_a1	-	-	-	gpio_34	-	-	safe_mode
M4	AB15	gpmc_a2	-	-	-	gpio_35	-	-	safe_mode
L4	AC16	gpmc_a3	-	-	-	gpio_36	-	-	safe_mode
K4	AB16	gpmc_a4	-	-	-	gpio_37	-	-	safe_mode
T3	AC17	gpmc_a5	-	-	-	gpio_38	-	-	safe_mode
R3	AB17	gpmc_a6	-	-	-	gpio_39	-	-	safe_mode
N3	AC18	gpmc_a7	-	-	-	gpio_40	-	-	safe_mode
M3	AB18	gpmc_a8	-	-	-	gpio_41	-	-	safe_mode
L3	AC19	gpmc_a9	sys_ndmareq2	-	-	gpio_42	-	-	safe_mode
K3	AB19	gpmc_a10	sys_ndmareq3	-	-	gpio_43	-	-	safe_mode
K1	M2	gpmc_d0	-	-	-	-	-	-	-
L1	M1	gpmc_d1	-	-	-	-	-	-	-
L2	N2	gpmc_d2	-	-	-	-	-	-	-
P2	N 1	gpmc_d3	-	-	-	-	-	-	-
T1	R2	gpmc_d4	-	-	-	-	-	-	-
V1	R1	gpmc_d5	-	-	-	-	-	-	-
V2	T2	gpmc_d6	-	-	-	-	-	-	-
W2	T1	gpmc_d7	-	-	-	-	-	-	-
H2	AB3	gpmc_d8	-	-	-	gpio_44	-	-	safe_mode

PRODUCT PREVIEW

Table 2-3. Multiplexing Characteristics (CBB Pkg.)⁽¹⁾ (continued)

Ball Bottom	Ball Top	Mode 0	Mode 1	Mode 2	Mode 3	Mode 4	Mode 5	Mode 6	Mode 7
K2	AC3	gpmc_d9	-	-	-	gpio_45	-	-	safe_mode
P1	AB4	gpmc_d10	-	-	-	gpio_46	-	-	safe_mode
R1	AC4	gpmc_d11	-	-	-	gpio_47	-	-	safe_mode
R2	AB6	gpmc_d12	-	-	-	gpio_48	-	-	safe_mode
T2	AC6	gpmc_d13	-	-	-	gpio_49	-	-	safe_mode
W1	AB7	gpmc_d14	-	-	-	gpio_50	-	-	safe_mode
Y1	AC7	gpmc_d15	-	-	-	gpio_51	-	-	safe_mode
G4	Y2	gpmc_ncs0	-	-	-	-	-	-	-
H3	Y1	gpmc_ncs1	-	-	-	gpio_52	-	-	safe_mode
V8	NA	gpmc_ncs2	-	-	-	gpio_53	-	-	safe_mode
U8	NA	gpmc_ncs3	sys_ ndmareq0	-	-	gpio_54	-	-	safe_mode
T8	NA	gpmc_ncs4	sys_ ndmareq1	mcbsp4_clkx	gpt9_pwm_ evt	gpio_55	-	-	safe_mode
R8	NA	gpmc_ncs5	sys_ ndmareq2	mcbsp4_dr	gpt10_pwm_ evt	gpio_56	-	-	safe_mode
P8	NA	gpmc_ncs6	sys_ ndmareq3	mcbsp4_dx	gpt11_pwm_ evt	gpio_57	-	-	safe_mode
N8	NA	gpmc_ncs7	gpmc_io_dir	mcbsp4_fsx	gpt8_pwm_ evt	gpio_58	-	-	safe_mode
T4	W2	gpmc_clk	-	-	-	gpio_59	-	-	safe_mode
F3	W1	gpmc_nadv_ ale	-	-	-	-	-	-	-
G2	V2	gpmc_noe	-	-	-	-	-	-	-
F4	V1	gpmc_nwe	-	-	-	-	-	-	-
G3	AC12	gpmc_nbe0_ cle	-	-	-	gpio_60	-	-	safe_mode
U3	NA	gpmc_nbe1	-	-	-	gpio_61	-	-	safe_mode
H1	AB10	gpmc_nwp	-	-	-	gpio_62	-	-	safe_mode
M8	AB12	gpmc_wait0	-	-	-	-	-	-	-
L8	AC10	gpmc_wait1	-	-	-	gpio_63	-	-	safe_mode
K8	NA	gpmc_wait2	-	-	-	gpio_64	-	-	safe_mode
J8	NA	gpmc_wait3	sys_ ndmareq1	-	-	gpio_65	-	-	safe_mode
D28	NA	dss_pclk	-	-	-	gpio_66	-	-	safe_mode
D26	NA	dss_hsync	-	-	-	gpio_67	-	-	safe_mode
D27	NA	dss_vsync	-	-	-	gpio_68	-	-	safe_mode
E27	NA	dss_acbias	-	-	-	gpio_69	-	-	safe_mode
AG22	NA	dss_data0	-	uart1_cts	-	gpio_70	-	-	safe_mode
AH22	NA	dss_data1	-	uart1_rts	-	gpio_71	-	-	safe_mode
AG23	NA	dss_data2	-	-	-	gpio_72	-	-	safe_mode
AH23	NA	dss_data3	-	-	-	gpio_73	-	-	safe_mode
AG24	NA	dss_data4	-	uart3_rx_irrx	-	gpio_74	-	-	safe_mode
AH24	NA	dss_data5	-	uart3_tx_irtx	-	gpio_75	-	-	safe_mode
E26	NA	dss_data6	-	uart1_tx	-	gpio_76	-	-	safe_mode
F28	NA	dss_data7	-	uart1_rx	-	gpio_77	-	-	safe_mode
F27	NA	dss_data8	-	-	-	gpio_78	-	-	safe_mode
G26	NA	dss_data9	-	-	-	gpio_79	-	-	safe_mode
AD28	NA	dss_data10	-	-	-	gpio_80	-	-	safe_mode

PRODUCT PREVIEW

Table 2-3. Multiplexing Characteristics (CBB Pkg.)⁽¹⁾ (continued)

Ball Bottom	Ball Top	Mode 0	Mode 1	Mode 2	Mode 3	Mode 4	Mode 5	Mode 6	Mode 7
AD27	NA	dss_data11	-	-	-	gpio_81	-	-	safe_mode
AB28	NA	dss_data12	-	-	-	gpio_82	-	-	safe_mode
AB27	NA	dss_data13	-	-	-	gpio_83	-	-	safe_mode
AA28	NA	dss_data14	-	-	-	gpio_84	-	-	safe_mode
AA27	NA	dss_data15	-	-	-	gpio_85	-	-	safe_mode
G25	NA	dss_data16	-	-	-	gpio_86	-	-	safe_mode
H27	NA	dss_data17	-	-	-	gpio_87	-	-	safe_mode
H26	NA	dss_data18	-	mcspi3_clk	dss_data0	gpio_88	-	-	safe_mode
H25	NA	dss_data19	-	mcspi3_simo	dss_data1	gpio_89	-	-	safe_mode
E28	NA	dss_data20	-	mcspi3_somi	dss_data2	gpio_90	-	-	safe_mode
J26	NA	dss_data21	-	mcspi3_cs0	dss_data3	gpio_91	-	-	safe_mode
AC27	NA	dss_data22	-	mcspi3_cs1	dss_data4	gpio_92	-	-	safe_mode
AC28	NA	dss_data23	-	-	dss_data5	gpio_93	-	-	safe_mode
W28	NA	tv_out2	-	-	-	-	-	-	-
Y28	NA	tv_out1	-	-	-	-	-	-	-
Y27	NA	tv_vfb1	-	-	-	-	-	-	-
W27	NA	tv_vfb2	-	-	-	-	-	-	-
W26	NA	tv_vref	-	-	-	-	-	-	-
A24	NA	cam_hs	-	-	-	gpio_94	-	-	safe_mode
A23	NA	cam_vs	-	-	-	gpio_95	-	-	safe_mode
C25	NA	cam_xclka	-	-	-	gpio_96	-	-	safe_mode
C27	NA	cam_pclk	-	-	-	gpio_97	-	-	safe_mode
C23	NA	cam_fld	-	cam_global_reset	-	gpio_98	-	-	safe_mode
AG17	NA	cam_d0	-	-	-	gpio_99	-	-	safe_mode
AH17	NA	cam_d1	-	-	-	gpio_100	-	-	safe_mode
B24	NA	cam_d2	-	-	-	gpio_101	-	-	safe_mode
C24	NA	cam_d3	-	-	-	gpio_102	-	-	safe_mode
D24	NA	cam_d4	-	-	-	gpio_103	-	-	safe_mode
A25	NA	cam_d5	-	-	-	gpio_104	-	-	safe_mode
K28	NA	cam_d6	-	-	-	gpio_105	-	-	safe_mode
L28	NA	cam_d7	-	-	-	gpio_106	-	-	safe_mode
K27	NA	cam_d8	-	-	-	gpio_107	-	-	safe_mode
L27	NA	cam_d9	-	-	-	gpio_108	-	-	safe_mode
B25	NA	cam_d10	-	-	-	gpio_109	-	-	safe_mode
C26	NA	cam_d11	-	-	-	gpio_110	-	-	safe_mode
B26	NA	cam_xclkb	-	-	-	gpio_111	-	-	safe_mode
B23	NA	cam_wen	-	cam_shutter	-	gpio_167	-	-	safe_mode
D25	NA	cam_strobe	-	-	-	gpio_126	-	-	safe_mode
AG19	NA	-	-	-	-	gpio_112	-	-	safe_mode
AH19	NA	-	-	-	-	gpio_113	-	-	safe_mode
AG18	NA	-	-	-	-	gpio_114	-	-	safe_mode
AH18	NA	-	-	-	-	gpio_115	-	-	safe_mode
P21	NA	mcbasp2_fsx	-	-	-	gpio_116	-	-	safe_mode
N21	NA	mcbasp2_clkx	-	-	-	gpio_117	-	-	safe_mode
R21	NA	mcbasp2_dr	-	-	-	gpio_118	-	-	safe_mode
M21	NA	mcbasp2_dx	-	-	-	gpio_119	-	-	safe_mode

PRODUCT PREVIEW

Table 2-3. Multiplexing Characteristics (CBB Pkg.)⁽¹⁾ (continued)

Ball Bottom	Ball Top	Mode 0	Mode 1	Mode 2	Mode 3	Mode 4	Mode 5	Mode 6	Mode 7
N28	N A	mmc1_clk	ms_clk	-	-	gpio_120	-	-	safe_mode
M27	NA	mmc1_cmd	ms_bs	-	-	gpio_121	-	-	safe_mode
N27	NA	mmc1_dat0	ms_dat0	-	-	gpio_122	-	-	safe_mode
N26	NA	mmc1_dat1	ms_dat1	-	-	gpio_123	-	-	safe_mode
N25	NA	mmc1_dat2	ms_dat2	-	-	gpio_124	-	-	safe_mode
P28	NA	mmc1_dat3	ms_dat3	-	-	gpio_125	-	-	safe_mode
P27	NA	mmc1_dat4	-	-	-	gpio_126	-	-	safe_mode
P26	NA	mmc1_dat5	-	-	-	gpio_127	-	-	safe_mode
R27	NA	mmc1_dat6	-	-	-	gpio_128	-	-	safe_mode
R25	NA	mmc1_dat7	-	-	-	gpio_129	-	-	safe_mode
AE2	NA	mmc2_clk	mcspi3_clk	-	-	gpio_130	-	-	safe_mode
AG5	NA	mmc2_cmd	mcspi3_simo	-	-	gpio_131	-	-	safe_mode
AH5	NA	mmc2_dat0	mcspi3_somi	-	-	gpio_132	-	-	safe_mode
AH4	NA	mmc2_dat1	-	-	-	gpio_133	-	-	safe_mode
AG4	NA	mmc2_dat2	mcspi3_cs1	-	-	gpio_134	-	-	safe_mode
AF4	NA	mmc2_dat3	mcspi3_cs0	-	-	gpio_135	-	-	safe_mode
AE4	NA	mmc2_dat4	mmc2_dir_dat0	-	mmc3_dat0	gpio_136	-	-	safe_mode
AH3	NA	mmc2_dat5	mmc2_dir_dat1	cam_global_reset	mmc3_dat1	gpio_137	hsusb3_tll_stp	mm3_rxdp	safe_mode
AF3	NA	mmc2_dat6	mmc2_dir_cmd	cam_shutter	mmc3_dat2	gpio_138	hsusb3_tll_dir	-	safe_mode
AE3	NA	mmc2_dat7	mmc2_clkin	-	mmc3_dat3	gpio_139	hsusb3_tll_nxt	mm3_rxdm	safe_mode
AF6	NA	mcbsp3_dx	uart2_cts	-	-	gpio_140	hsusb3_tll_data4	-	safe_mode
AE6	NA	mcbsp3_dr	uart2_rts	-	-	gpio_141	hsusb3_tll_data5	-	safe_mode
AF5	NA	mcbsp3_clkx	uart2_tx	-	-	gpio_142	hsusb3_tll_data6	-	safe_mode
AE5	NA	mcbsp3_fsx	uart2_rx	-	-	gpio_143	hsusb3_tll_data7	-	safe_mode
AB26	NA	uart2_cts	mcbsp3_dx	gpt9_pwm_evt	-	gpio_144	-	-	safe_mode
AB25	NA	uart2_rts	mcbsp3_dr	gpt10_pwm_evt	-	gpio_145	-	-	safe_mode
AA25	NA	uart2_tx	mcbsp3_clkx	gpt11_pwm_evt	-	gpio_146	-	-	safe_mode
AD25	NA	uart2_rx	mcbsp3_fsx	gpt8_pwm_evt	-	gpio_147	-	-	safe_mode
AA8	NA	uart1_tx	-	-	-	gpio_148	-	-	safe_mode
AA9	NA	uart1_rts	-	-	-	gpio_149	-	-	safe_mode
W8	NA	uart1_cts	-	-	-	gpio_150	hsusb3_tll_clk	-	safe_mode
Y8	NA	uart1_rx	-	mcbsp1_clkr	mcspi4_clk	gpio_151	-	-	safe_mode
AE1	NA	mcbsp4_clkx	-	-	-	gpio_152	hsusb3_tll_data1	mm3_txse0	safe_mode
AD1	NA	mcbsp4_dr	-	-	-	gpio_153	hsusb3_tll_data0	mm3_rxcv	safe_mode
AD2	NA	mcbsp4_dx	-	-	-	gpio_154	hsusb3_tll_data2	mm3_txdat	safe_mode

PRODUCT PREVIEW

Table 2-3. Multiplexing Characteristics (CBB Pkg.)⁽¹⁾ (continued)

Ball Bottom	Ball Top	Mode 0	Mode 1	Mode 2	Mode 3	Mode 4	Mode 5	Mode 6	Mode 7
AC1	NA	mcbbsp4_fsx	-	-	-	gpio_155	hsusb3_tll_data3	mm3_txen_n	safe_mode
Y21	NA	mcbbsp1_clkr	mcspi4_clk	-	-	gpio_156	-	-	safe_mode
AA21	NA	mcbbsp1_fsr	adpll2d_dithering_en1	cam_global_reset	-	gpio_157	-	-	safe_mode
V21	NA	mcbbsp1_dx	mcspi4_simo	mcbbsp3_dx	-	gpio_158	-	-	safe_mode
U21	NA	mcbbsp1_dr	mcspi4_somi	mcbbsp3_dr	-	gpio_159	-	-	safe_mode
T21	NA	mcbbsp_clks	-	cam_shutter	-	gpio_160	uart1_cts	-	safe_mode
K26	NA	mcbbsp1_fsx	mcspi4_cs0	mcbbsp3_fsx	-	gpio_161	-	-	safe_mode
W21	NA	mcbbsp1_clkx	-	mcbbsp3_clkx	-	gpio_162	-	-	safe_mode
H18	NA	uart3_cts_rctx	-	-	-	gpio_163	-	-	safe_mode
H19	NA	uart3_rts_sd	-	-	-	gpio_164	-	-	safe_mode
H20	NA	uart3_rx_irrx	-	-	-	gpio_165	-	-	safe_mode
H21	NA	uart3_tx_irtx	-	-	-	gpio_166	-	-	safe_mode
T28	NA	hsusb0_clk	-	-	-	gpio_120	-	-	safe_mode
T25	NA	hsusb0_stp	-	-	-	gpio_121	-	-	safe_mode
R28	NA	hsusb0_dir	-	-	-	gpio_122	-	-	safe_mode
T26	NA	hsusb0_nxt	-	-	-	gpio_124	-	-	safe_mode
T27	NA	hsusb0_data0	-	uart3_tx_irtx	-	gpio_125	-	-	safe_mode
U28	NA	hsusb0_data1	-	uart3_rx_irrx	-	gpio_130	-	-	safe_mode
U27	NA	hsusb0_data2	-	uart3_rts_sd	-	gpio_131	-	-	safe_mode
U26	NA	hsusb0_data3	-	uart3_cts_rctx	-	gpio_169	-	-	safe_mode
U25	NA	hsusb0_data4	-	-	-	gpio_188	-	-	safe_mode
V28	NA	hsusb0_data5	-	-	-	gpio_189	-	-	safe_mode
V27	NA	hsusb0_data6	-	-	-	gpio_190	-	-	safe_mode
V26	NA	hsusb0_data7	-	-	-	gpio_191	-	-	safe_mode
K21	NA	i2c1_scl	-	-	-	-	-	-	-
J21	NA	i2c1_sda	-	-	-	-	-	-	-
AF15	NA	i2c2_scl	-	-	-	gpio_168	-	-	safe_mode
AE15	NA	i2c2_sda	-	-	-	gpio_183	-	-	safe_mode
AF14	NA	i2c3_scl	-	-	-	gpio_184	-	-	safe_mode
AG14	NA	i2c3_sda	-	-	-	gpio_185	-	-	safe_mode
AD26	NA	i2c4_scl	sys_nvmode1	-	-	-	-	-	safe_mode
AE26	NA	i2c4_sda	sys_nvmode2	-	-	-	-	-	safe_mode
J25	NA	hdq_sio	sys_altclk	i2c2_sccbe	i2c3_sccbe	gpio_170	-	-	safe_mode
AB3	NA	mcspi1_clk	mmc2_dat4	-	-	gpio_171	-	-	safe_mode
AB4	NA	mcspi1_simo	mmc2_dat5	-	-	gpio_172	-	-	safe_mode
AA4	NA	mcspi1_somi	mmc2_dat6	-	-	gpio_173	-	-	safe_mode
AC2	NA	mcspi1_cs0	mmc2_dat7	-	-	gpio_174	-	-	safe_mode

PRODUCT PREVIEW

Table 2-3. Multiplexing Characteristics (CBB Pkg.)⁽¹⁾ (continued)

Ball Bottom	Ball Top	Mode 0	Mode 1	Mode 2	Mode 3	Mode 4	Mode 5	Mode 6	Mode 7
AC3	NA	mcspi1_cs1	adpll2d_dithering_en2	-	mmc3_cmd	gpio_175	-	-	safe_mode
AB1	NA	mcspi1_cs2	-	-	mmc3_clk	gpio_176	-	-	safe_mode
AB2	NA	mcspi1_cs3	-	hsusb2_tll_data2	hsusb2_data2	gpio_177	mm2_txdat	-	safe_mode
AA3	NA	mcspi2_clk	-	hsusb2_tll_data7	hsusb2_data7	gpio_178	-	-	safe_mode
Y2	NA	mcspi2_simo	gpt9_pwm_evt	hsusb2_tll_data4	hsusb2_data4	gpio_179	-	-	safe_mode
Y3	NA	mcspi2_somi	gpt10_pwm_evt	hsusb2_tll_data5	hsusb2_data5	gpio_180	-	-	safe_mode
Y4	NA	mcspi2_cs0	gpt11_pwm_evt	hsusb2_tll_data6	hsusb2_data6	gpio_181	-	-	safe_mode
V3	NA	mcspi2_cs1	gpt8_pwm_evt	hsusb2_tll_data3	hsusb2_data3	gpio_182	mm2_txen_n	-	safe_mode
AE25	NA	sys_32k	-	-	-	-	-	-	-
AE17	NA	sys_xtalin	-	-	-	-	-	-	-
AF17	NA	sys_xtalout	-	-	-	-	-	-	-
AF25	NA	sys_clkreq	-	-	-	gpio_1	-	-	safe_mode
AF26	NA	sys_nirq	-	-	-	gpio_0	-	-	safe_mode
AH25	NA	sys_nrespwr_on	-	-	-	-	-	-	-
AF24	NA	sys_nreswarm	-	-	-	gpio_30	-	-	safe_mode
AH26	NA	sys_boot0	-	-	-	gpio_2	-	-	safe_mode
AG26	NA	sys_boot1	-	-	-	gpio_3	-	-	safe_mode
AE14	NA	sys_boot2	-	-	-	gpio_4	-	-	safe_mode
AF18	NA	sys_boot3	-	-	-	gpio_5	-	-	safe_mode
AF19	NA	sys_boot4	mmc2_dir_dat2	-	-	gpio_6	-	-	safe_mode
AE21	NA	sys_boot5	mmc2_dir_dat3	-	-	gpio_7	-	-	safe_mode
AF21	NA	sys_boot6	-	-	-	gpio_8	-	-	safe_mode
AF22	NA	sys_off_mode	-	-	-	gpio_9	-	-	safe_mode
AG25	NA	sys_clkout1	-	-	-	gpio_10	-	-	safe_mode
AE22	NA	sys_clkout2	-	-	-	gpio_186	-	-	safe_mode
B1	NA	sys_ipmcsws	-	-	-	-	-	-	-
A1	NA	sys_opmcsws	-	-	-	-	-	-	-
AA17	NA	jtag_nrst	-	-	-	-	-	-	-
AA13	NA	jtag_tck	-	-	-	-	-	-	-
AA12	NA	jtag_rtck	-	-	-	-	-	-	-
AA18	NA	jtag_tms_tmsc	-	-	-	-	-	-	-
AA20	NA	jtag_tdi	-	-	-	-	-	-	-
AA19	NA	jtag_tdo	-	-	-	-	-	-	-
AA11	NA	jtag_emu0	-	-	-	gpio_11	-	-	safe_mode
AA10	NA	jtag_emu1	-	-	-	gpio_31	-	-	safe_mode

PRODUCT PREVIEW

Table 2-3. Multiplexing Characteristics (CBB Pkg.)⁽¹⁾ (continued)

Ball Bottom	Ball Top	Mode 0	Mode 1	Mode 2	Mode 3	Mode 4	Mode 5	Mode 6	Mode 7
AF10	NA	etk_clk	mcbasp5_clkx	mmc3_clk	hsusb1_stp	gpio_12	mm1_rxdp	hsusb1_tll_stp	-
AE10	NA	etk_ctl	-	mmc3_cmd	hsusb1_clk	gpio_13	-	hsusb1_tll_clk	-
AF11	NA	etk_d0	mcspi3_simo	mmc3_dat4	hsusb1_data0	gpio_14	mm1_rxcv	hsusb1_tll_data0	-
AG12	NA	etk_d1	mcspi3_somi	-	hsusb1_data1	gpio_15	mm1_txse0	hsusb1_tll_data1	-
AH12	NA	etk_d2	mcspi3_cs0	-	hsusb1_data2	gpio_16	mm1_txdat	hsusb1_tll_data2	-
AE13	NA	etk_d3	mcspi3_clk	mmc3_dat3	hsusb1_data7	gpio_17	-	hsusb1_tll_data7	-
AE11	NA	etk_d4	mcbasp5_dr	mmc3_dat0	hsusb1_data4	gpio_18	-	hsusb1_tll_data4	-
AH9	NA	etk_d5	mcbasp5_fsx	mmc3_dat1	hsusb1_data5	gpio_19	-	hsusb1_tll_data5	-
AF13	NA	etk_d6	mcbasp5_dx	mmc3_dat2	hsusb1_data6	gpio_20	-	hsusb1_tll_data6	-
AH14	NA	etk_d7	mcspi3_cs1	mmc3_dat7	hsusb1_data3	gpio_21	mm1_txen_n	hsusb1_tll_data3	-
AF9	NA	etk_d8	sys_drm_msecure	mmc3_dat6	hsusb1_dir	gpio_22	-	hsusb1_tll_dir	-
AG9	NA	etk_d9	sys_secure_indicator	mmc3_dat5	hsusb1_nxt	gpio_23	mm1_rxdm	hsusb1_tll_nxt	-
AE7	NA	etk_d10	-	uart1_rx	hsusb2_clk	gpio_24	-	hsusb2_tll_clk	-
AF7	NA	etk_d11	-	-	hsusb2_stp	gpio_25	mm2_rxdp	hsusb2_tll_stp	-
AG7	NA	etk_d12	-	-	hsusb2_dir	gpio_26	-	hsusb2_tll_dir	-
AH7	NA	etk_d13	-	-	hsusb2_nxt	gpio_27	mm2_rxdm	hsusb2_tll_nxt	-
AG8	NA	etk_d14	-	-	hsusb2_data0	gpio_28	mm2_rxcv	hsusb2_tll_data0	-
AH8	NA	etk_d15	-	-	hsusb2_data1	gpio_29	mm2_txse0	hsusb2_tll_data1	-

(1) NA in table stands for Not Applicable.

Table 2-4. Multiplexing Characteristics (CUS Pkg.)⁽¹⁾

Ball Bottom	Mode 0	Mode 1	Mode 2	Mode 3	Mode 4	Mode 5	Mode 6	Mode 7
D7	sdrc_d0	-	-	-	-	-	-	-
C5	sdrc_d1	-	-	-	-	-	-	-
C6	sdrc_d2	-	-	-	-	-	-	-
B5	sdrc_d3	-	-	-	-	-	-	-
D9	sdrc_d4	-	-	-	-	-	-	-
D10	sdrc_d5	-	-	-	-	-	-	-
C7	sdrc_d6	-	-	-	-	-	-	-
B7	sdrc_d7	-	-	-	-	-	-	-
B11	sdrc_d8	-	-	-	-	-	-	-
C12	sdrc_d9	-	-	-	-	-	-	-
B12	sdrc_d10	-	-	-	-	-	-	-
D13	sdrc_d11	-	-	-	-	-	-	-
C13	sdrc_d12	-	-	-	-	-	-	-
B14	sdrc_d13	-	-	-	-	-	-	-
A14	sdrc_d14	-	-	-	-	-	-	-
B15	sdrc_d15	-	-	-	-	-	-	-
C9	sdrc_d16	-	-	-	-	-	-	-
E12	sdrc_d17	-	-	-	-	-	-	-
B8	sdrc_d18	-	-	-	-	-	-	-
B9	sdrc_d19	-	-	-	-	-	-	-
C10	sdrc_d20	-	-	-	-	-	-	-
B10	sdrc_d21	-	-	-	-	-	-	-
D12	sdrc_d22	-	-	-	-	-	-	-
E13	sdrc_d23	-	-	-	-	-	-	-
E15	sdrc_d24	-	-	-	-	-	-	-
D15	sdrc_d25	-	-	-	-	-	-	-
C15	sdrc_d26	-	-	-	-	-	-	-
B16	sdrc_d27	-	-	-	-	-	-	-
C16	sdrc_d28	-	-	-	-	-	-	-
D16	sdrc_d29	-	-	-	-	-	-	-
B17	sdrc_d30	-	-	-	-	-	-	-
B18	sdrc_d31	-	-	-	-	-	-	-
C18	sdrc_ba0	-	-	-	-	-	-	-
D18	sdrc_ba1	-	-	-	-	-	-	-
A4	sdrc_a0	-	-	-	-	-	-	-
B4	sdrc_a1	-	-	-	-	-	-	-
D6	sdrc_a2	-	-	-	-	-	-	-
B3	sdrc_a3	-	-	-	-	-	-	-
B2	sdrc_a4	-	-	-	-	-	-	-
C3	sdrc_a5	-	-	-	-	-	-	-
E3	sdrc_a6	-	-	-	-	-	-	-
F6	sdrc_a7	-	-	-	-	-	-	-
E10	sdrc_a8	-	-	-	-	-	-	-
E9	sdrc_a9	-	-	-	-	-	-	-
E7	sdrc_a10	-	-	-	-	-	-	-
G6	sdrc_a11	-	-	-	-	-	-	-

PRODUCT PREVIEW

Table 2-4. Multiplexing Characteristics (CUS Pkg.)⁽¹⁾ (continued)

Ball Bottom	Mode 0	Mode 1	Mode 2	Mode 3	Mode 4	Mode 5	Mode 6	Mode 7
G7	sdrc_a12	-	-	-	-	-	-	-
F7	sdrc_a13	-	-	-	-	-	-	-
F9	sdrc_a14	-	-	-	-	-	-	-
A19	sdrc_ncs0	-	-	-	-	-	-	-
B19	sdrc_ncs1	-	-	-	-	-	-	-
A10	sdrc_clk	-	-	-	-	-	-	-
A11	sdrc_nclk	-	-	-	-	-	-	-
B20	sdrc_cke0	-	-	-	-	-	-	safe_mode
C20	sdrc_cke1	-	-	-	-	-	-	safe_mode
D19	sdrc_nras	-	-	-	-	-	-	-
C19	sdrc_ncas	-	-	-	-	-	-	-
A20	sdrc_nwe	-	-	-	-	-	-	-
B6	sdrc_dm0	-	-	-	-	-	-	-
B13	sdrc_dm1	-	-	-	-	-	-	-
A7	sdrc_dm2	-	-	-	-	-	-	-
A16	sdrc_dm3	-	-	-	-	-	-	-
A5	sdrc_dqs0	-	-	-	-	-	-	-
A13	sdrc_dqs1	-	-	-	-	-	-	-
A8	sdrc_dqs2	-	-	-	-	-	-	-
A17	sdrc_dqs3	-	-	-	-	-	-	-
K4	gpmc_a1	-	-	-	gpio_34	-	-	safe_mode
K3	gpmc_a2	-	-	-	gpio_35	-	-	safe_mode
K2	gpmc_a3	-	-	-	gpio_36	-	-	safe_mode
J4	gpmc_a4	-	-	-	gpio_37	-	-	safe_mode
J3	gpmc_a5	-	-	-	gpio_38	-	-	safe_mode
J2	gpmc_a6	-	-	-	gpio_39	-	-	safe_mode
J1	gpmc_a7	-	-	-	gpio_40	-	-	safe_mode
H1	gpmc_a8	-	-	-	gpio_41	-	-	safe_mode
H2	gpmc_a9	sys_ndmareq2	-	-	gpio_42	-	-	safe_mode
G2	gpmc_a10	sys_ndmareq3	-	-	gpio_43	-	-	safe_mode
L2	gpmc_d0	-	-	-	-	-	-	-
M1	gpmc_d1	-	-	-	-	-	-	-
M2	gpmc_d2	-	-	-	-	-	-	-
N2	gpmc_d3	-	-	-	-	-	-	-
M3	gpmc_d4	-	-	-	-	-	-	-
P1	gpmc_d5	-	-	-	-	-	-	-
P2	gpmc_d6	-	-	-	-	-	-	-
R1	gpmc_d7	-	-	-	-	-	-	-
R2	gpmc_d8	-	-	-	gpio_44	-	-	safe_mode
T2	gpmc_d9	-	-	-	gpio_45	-	-	safe_mode
U1	gpmc_d10	-	-	-	gpio_46	-	-	safe_mode
R3	gpmc_d11	-	-	-	gpio_47	-	-	safe_mode
T3	gpmc_d12	-	-	-	gpio_48	-	-	safe_mode
U2	gpmc_d13	-	-	-	gpio_49	-	-	safe_mode
V1	gpmc_d14	-	-	-	gpio_50	-	-	safe_mode

PRODUCT PREVIEW

Table 2-4. Multiplexing Characteristics (CUS Pkg.)⁽¹⁾ (continued)

Ball Bottom	Mode 0	Mode 1	Mode 2	Mode 3	Mode 4	Mode 5	Mode 6	Mode 7
V2	gpmc_d15	-	-	-	gpio_51	-	-	safe_mode
E2	gpmc_ncs0	-	-	-	-	-	-	-
D2	gpmc_ncs3	sys_ndmareq0	-	-	gpio_54	-	-	safe_mode
F4	gpmc_ncs4	sys_ndmareq1	mcbsp4_clkx	gpt9_pwm_evt	gpio_55	-	-	safe_mode
G5	gpmc_ncs5	sys_ndmareq2	mcbsp4_dr	gpt10_pwm_evt	gpio_56	-	-	safe_mode
F3	gpmc_ncs6	sys_ndmareq3	mcbsp4_dx	gpt11_pwm_evt	gpio_57	-	-	safe_mode
G4	gpmc_ncs7	gpmc_io_dir	mcbsp4_fsx	gpt8_pwm_evt	gpio_58	-	-	safe_mode
W2	gpmc_clk	-	-	-	gpio_59	-	-	safe_mode
F1	gpmc_nadv_a le	-	-	-	-	-	-	-
F2	gpmc_noe	-	-	-	-	-	-	-
G3	gpmc_nwe	-	-	-	-	-	-	-
K5	gpmc_nbe0_c le	-	-	-	gpio_60	-	-	safe_mode
L1	gpmc_nbe1	-	-	-	gpio_61	-	-	safe_mode
E1	gpmc_nwp	-	-	-	gpio_62	-	-	safe_mode
C1	gpmc_wait0	-	-	-	-	-	-	-
C2	gpmc_wait3	sys_ndmareq1	-	-	gpio_65	-	-	safe_mode
G22	dss_pclk	-	-	-	gpio_66	-	-	safe_mode
E22	dss_hsync	-	-	-	gpio_67	-	-	safe_mode
F22	dss_vsync	-	-	-	gpio_68	-	-	safe_mode
J21	dss_acbias	-	-	-	gpio_69	-	-	safe_mode
AC19	dss_data0	-	uart1_cts	-	gpio_70	-	-	safe_mode
AB19	dss_data1	-	uart1_rts	-	gpio_71	-	-	safe_mode
AD20	dss_data2	-	-	-	gpio_72	-	-	safe_mode
AC20	dss_data3	-	-	-	gpio_73	-	-	safe_mode
AD21	dss_data4	-	uart3_rx_irrx	-	gpio_74	-	-	safe_mode
AC21	dss_data5	-	uart3_tx_irtx	-	gpio_75	-	-	safe_mode
D24	dss_data6	-	uart1_tx	-	gpio_76	-	-	safe_mode
E23	dss_data7	-	uart1_rx	-	gpio_77	-	-	safe_mode
E24	dss_data8	-	-	-	gpio_78	-	-	safe_mode
F23	dss_data9	-	-	-	gpio_79	-	-	safe_mode
AC22	dss_data10	-	-	-	gpio_80	-	-	safe_mode
AC23	dss_data11	-	-	-	gpio_81	-	-	safe_mode
AB22	dss_data12	-	-	-	gpio_82	-	-	safe_mode
Y22	dss_data13	-	-	-	gpio_83	-	-	safe_mode
W22	dss_data14	-	-	-	gpio_84	-	-	safe_mode
V22	dss_data15	-	-	-	gpio_85	-	-	safe_mode
J22	dss_data16	-	-	-	gpio_86	-	-	safe_mode
G23	dss_data17	-	-	-	gpio_87	-	-	safe_mode
G24	dss_data18	-	mcspi3_clk	dss_data0	gpio_88	-	-	safe_mode
H23	dss_data19	-	mcspi3_simo	dss_data1	gpio_89	-	-	safe_mode
D23	dss_data20	-	mcspi3_somi	dss_data2	gpio_90	-	-	safe_mode

PRODUCT PREVIEW

Table 2-4. Multiplexing Characteristics (CUS Pkg.)⁽¹⁾ (continued)

Ball Bottom	Mode 0	Mode 1	Mode 2	Mode 3	Mode 4	Mode 5	Mode 6	Mode 7
K22	dss_data21	-	mcspi3_cs0	dss_data3	gpio_91	-	-	safe_mode
V21	dss_data22	-	mcspi3_cs1	dss_data4	gpio_92	-	-	safe_mode
W21	dss_data23	-	-	dss_data5	gpio_93	-	-	safe_mode
AA23	tv_out2	-	-	-	-	-	-	-
AB24	tv_out1	-	-	-	-	-	-	-
AB23	tv_vfb1	-	-	-	-	-	-	-
Y23	tv_vfb2	-	-	-	-	-	-	-
Y24	tv_vref	-	-	-	-	-	-	-
A22	cam_hs	-	-	-	gpio_94	-	-	safe_mode
E18	cam_vs	-	-	-	gpio_95	-	-	safe_mode
B22	cam_xclka	-	-	-	gpio_96	-	-	safe_mode
J19	cam_pclk	-	-	-	gpio_97	-	-	safe_mode
H24	cam_fld	-	cam_global_r eset	-	gpio_98	-	-	safe_mode
AB18	cam_d0	-	-	-	gpio_99	-	-	safe_mode
AC18	cam_d1	-	-	-	gpio_100	-	-	safe_mode
G19	cam_d2	-	-	-	gpio_101	-	-	safe_mode
F19	cam_d3	-	-	-	gpio_102	-	-	safe_mode
G20	cam_d4	-	-	-	gpio_103	-	-	safe_mode
B21	cam_d5	-	-	-	gpio_104	-	-	safe_mode
L24	cam_d6	-	-	-	gpio_105	-	-	safe_mode
K24	cam_d7	-	-	-	gpio_106	-	-	safe_mode
J23	cam_d8	-	-	-	gpio_107	-	-	safe_mode
K23	cam_d9	-	-	-	gpio_108	-	-	safe_mode
F21	cam_d10	-	-	-	gpio_109	-	-	safe_mode
G21	cam_d11	-	-	-	gpio_110	-	-	safe_mode
C22	cam_xclkb	-	-	-	gpio_111	-	-	safe_mode
F18	cam_wen	-	cam_shutter	-	gpio_167	-	-	safe_mode
J20	cam_strobe	-	-	-	gpio_126	-	-	safe_mode
V20	mcbasp2_fsx	-	-	-	gpio_116	-	-	safe_mode
T21	mcbasp2_clkx	-	-	-	gpio_117	-	-	safe_mode
V19	mcbasp2_dr	-	-	-	gpio_118	-	-	safe_mode
R20	mcbasp2_dx	-	-	-	gpio_119	-	-	safe_mode
M23	mmc1_clk	ms_clk	-	-	gpio_120	-	-	safe_mode
L23	mmc1_cmd	ms_bs	-	-	gpio_121	-	-	safe_mode
M22	mmc1_dat0	ms_dat0	-	-	gpio_122	-	-	safe_mode
M21	mmc1_dat1	ms_dat1	-	-	gpio_123	-	-	safe_mode
M20	mmc1_dat2	ms_dat2	-	-	gpio_124	-	-	safe_mode
N23	mmc1_dat3	ms_dat3	-	-	gpio_125	-	-	safe_mode
N22	mmc1_dat4	-	-	-	gpio_126	-	-	safe_mode
N21	mmc1_dat5	-	-	-	gpio_127	-	-	safe_mode
N20	mmc1_dat6	-	-	-	gpio_128	-	-	safe_mode
P24	mmc1_dat7	-	-	-	gpio_129	-	-	safe_mode
Y1	mmc2_clk	mcspi3_clk	-	-	gpio_130	-	-	safe_mode
AB5	mmc2_cmd	mcspi3_simo	-	-	gpio_131	-	-	safe_mode
AB3	mmc2_dat0	mcspi3_somi	-	-	gpio_132	-	-	safe_mode
Y3	mmc2_dat1	-	-	-	gpio_133	-	-	safe_mode

PRODUCT PREVIEW

Table 2-4. Multiplexing Characteristics (CUS Pkg.)⁽¹⁾ (continued)

Ball Bottom	Mode 0	Mode 1	Mode 2	Mode 3	Mode 4	Mode 5	Mode 6	Mode 7
W3	mmc2_dat2	mcspi3_cs1	-	-	gpio_134	-	-	safe_mode
V3	mmc2_dat3	mcspi3_cs0	-	-	gpio_135	-	-	safe_mode
AB2	mmc2_dat4	mmc2_dir_dat0	-	mmc3_dat0	gpio_136	-	-	safe_mode
AA2	mmc2_dat5	mmc2_dir_dat1	cam_global_r eset	mmc3_dat1	gpio_137	-	-	safe_mode
Y2	mmc2_dat6	mmc2_dir_cmd	cam_shutter	mmc3_dat2	gpio_138	-	-	safe_mode
AA1	mmc2_dat7	mmc2_clkln	-	mmc3_dat3	gpio_139	-	-	safe_mode
V6	mcbasp3_dx	uart2_cts	-	-	gpio_140	-	-	safe_mode
V5	mcbasp3_dr	uart2_rts	-	-	gpio_141	-	-	safe_mode
W4	mcbasp3_clkx	uart2_tx	-	-	gpio_142	-	-	safe_mode
V4	mcbasp3_fsx	uart2_rx	-	-	gpio_143	-	-	safe_mode
W7	uart1_tx	-	-	-	gpio_148	-	-	safe_mode
W6	uart1_rts	-	-	-	gpio_149	-	-	safe_mode
AC2	uart1_cts	-	-	-	gpio_150	-	-	safe_mode
V7	uart1_rx	-	mcbasp1_clkr	mcspi4_clk	gpio_151	-	-	safe_mode
W19	mcbasp1_clkr	mcspi4_clk	-	-	gpio_156	-	-	safe_mode
AB20	mcbasp1_fsr	adpll2d_dithering_en1	cam_global_r eset	-	gpio_157	-	-	safe_mode
W18	mcbasp1_dx	mcspi4_simo	mcbasp3_dx	-	gpio_158	-	-	safe_mode
Y18	mcbasp1_dr	mcspi4_somi	mcbasp3_dr	-	gpio_159	-	-	safe_mode
AA18	mcbasp_clks	-	cam_shutter	-	gpio_160	uart1_cts	-	safe_mode
AA19	mcbasp1_fsx	mcspi4_cs0	mcbasp3_fsx	-	gpio_161	-	-	safe_mode
V18	mcbasp1_clkx	-	mcbasp3_clkx	-	gpio_162	-	-	safe_mode
A23	uart3_cts_rctx	-	-	-	gpio_163	-	-	safe_mode
B23	uart3_rts_sd	-	-	-	gpio_164	-	-	safe_mode
B24	uart3_rx_irrx	-	-	-	gpio_165	-	-	safe_mode
C23	uart3_tx_irtx	-	-	-	gpio_166	-	-	safe_mode
R21	hsusb0_clk	-	-	-	gpio_120	-	-	safe_mode
R23	hsusb0_stp	-	-	-	gpio_121	-	-	safe_mode
P23	hsusb0_dir	-	-	-	gpio_122	-	-	safe_mode
R22	hsusb0_nxt	-	-	-	gpio_124	-	-	safe_mode
T24	hsusb0_data0	-	uart3_tx_irtx	-	gpio_125	-	-	safe_mode
T23	hsusb0_data1	-	uart3_rx_irrx	-	gpio_130	-	-	safe_mode
U24	hsusb0_data2	-	uart3_rts_sd	-	gpio_131	-	-	safe_mode
U23	hsusb0_data3	-	uart3_cts_rctx	-	gpio_169	-	-	safe_mode
W24	hsusb0_data4	-	-	-	gpio_188	-	-	safe_mode
V23	hsusb0_data5	-	-	-	gpio_189	-	-	safe_mode
W23	hsusb0_data6	-	-	-	gpio_190	-	-	safe_mode
T22	hsusb0_data7	-	-	-	gpio_191	-	-	safe_mode
K20	i2c1_scl	-	-	-	-	-	-	-

PRODUCT PREVIEW

Table 2-4. Multiplexing Characteristics (CUS Pkg.)⁽¹⁾ (continued)

Ball Bottom	Mode 0	Mode 1	Mode 2	Mode 3	Mode 4	Mode 5	Mode 6	Mode 7
K21	i2c1_sda	-	-	-	-	-	-	-
AC15	i2c2_scl	-	-	-	gpio_168	-	-	safe_mode
AC14	i2c2_sda	-	-	-	gpio_183	-	-	safe_mode
AC13	i2c3_scl	-	-	-	gpio_184	-	-	safe_mode
AC12	i2c3_sda	-	-	-	gpio_185	-	-	safe_mode
Y16	i2c4_scl	sys_nvmode1	-	-	-	-	-	safe_mode
Y15	i2c4_sda	sys_nvmode2	-	-	-	-	-	safe_mode
A24	hdq_sio	sys_altclk	i2c2_sccbe	i2c3_sccbe	gpio_170	-	-	safe_mode
T5	mcspi1_clk	mmc2_dat4	-	-	gpio_171	-	-	safe_mode
R4	mcspi1_simo	mmc2_dat5	-	-	gpio_172	-	-	safe_mode
T4	mcspi1_somi	mmc2_dat6	-	-	gpio_173	-	-	safe_mode
T6	mcspi1_cs0	mmc2_dat7	-	-	gpio_174	-	-	safe_mode
R5	mcspi1_cs3	-	hsusb2_tll_data2	hsusb2_data2	gpio_177	mm2_txdat	-	safe_mode
N5	mcspi2_clk	-	hsusb2_tll_data7	hsusb2_data7	gpio_178	-	-	safe_mode
N4	mcspi2_simo	gpt9_pwm_evt	hsusb2_tll_data4	hsusb2_data4	gpio_179	-	-	safe_mode
N3	mcspi2_somi	gpt10_pwm_evt	hsusb2_tll_data5	hsusb2_data5	gpio_180	-	-	safe_mode
M5	mcspi2_cs0	gpt11_pwm_evt	hsusb2_tll_data6	hsusb2_data6	gpio_181	-	-	safe_mode
M4	mcspi2_cs1	gpt8_pwm_evt	hsusb2_tll_data3	hsusb2_data3	gpio_182	mm2_txen_n	-	safe_mode
AA16	sys_32k	-	-	-	-	-	-	-
AD15	sys_xtalin	-	-	-	-	-	-	-
AD14	sys_xtalout	-	-	-	-	-	-	-
Y13	sys_clkreq	-	-	-	gpio_1	-	-	safe_mode
W16	sys_nirq	-	-	-	gpio_0	-	-	safe_mode
AA10	sys_nrespwrn	-	-	-	-	-	-	-
Y10	sys_nreswarm	-	-	-	gpio_30	-	-	safe_mode
AB12	sys_boot0	-	-	-	gpio_2	-	-	safe_mode
AC16	sys_boot1	-	-	-	gpio_3	-	-	safe_mode
AD17	sys_boot2	-	-	-	gpio_4	-	-	safe_mode
AD18	sys_boot3	-	-	-	gpio_5	-	-	safe_mode
AC17	sys_boot4	mmc2_dir_dat2	-	-	gpio_6	-	-	safe_mode
AB16	sys_boot5	mmc2_dir_dat3	-	-	gpio_7	-	-	safe_mode
AA15	sys_boot6	-	-	-	gpio_8	-	-	safe_mode
AD23	sys_off_mode	-	-	-	gpio_9	-	-	safe_mode
Y7	sys_clkout1	-	-	-	gpio_10	-	-	safe_mode
AA6	sys_clkout2	-	-	-	gpio_186	-	-	safe_mode
A1	sys_ipmcsws	-	-	-	-	-	-	-
A2	sys_opmcsws	-	-	-	-	-	-	-

PRODUCT PREVIEW

Table 2-4. Multiplexing Characteristics (CUS Pkg.)⁽¹⁾ (continued)

Ball Bottom	Mode 0	Mode 1	Mode 2	Mode 3	Mode 4	Mode 5	Mode 6	Mode 7
AB7	jtag_nrst	-	-	-	-	-	-	-
AB6	jtag_tck	-	-	-	-	-	-	-
AA7	jtag_rtck	-	-	-	-	-	-	-
AA9	jtag_tms_tmsc	-	-	-	-	-	-	-
AB10	jtag_tdi	-	-	-	-	-	-	-
AB9	jtag_tdo	-	-	-	-	-	-	-
AC24	jtag_emu0	-	-	-	gpio_11	-	-	safe_mode
AD24	jtag_emu1	-	-	-	gpio_31	-	-	safe_mode
AC1	etk_clk	mcbasp5_clkx	mmc3_clk	hsusb1_stp	gpio_12	mm1_rxdp	hsusb1_tll_stp	-
AD3	etk_ctl	-	mmc3_cmd	hsusb1_clk	gpio_13	-	hsusb1_tll_clk	-
AD6	etk_d0	mcspi3_simo	mmc3_dat4	hsusb1_data0	gpio_14	mm1_rxcv	hsusb1_tll_data0	-
AC6	etk_d1	mcspi3_somi	-	hsusb1_data1	gpio_15	mm1_txse0	hsusb1_tll_data1	-
AC7	etk_d2	mcspi3_cs0	-	hsusb1_data2	gpio_16	mm1_txdat	hsusb1_tll_data2	-
AD8	etk_d3	mcspi3_clk	mmc3_dat3	hsusb1_data7	gpio_17	-	hsusb1_tll_data7	-
AC5	etk_d4	mcbasp5_dr	mmc3_dat0	hsusb1_data4	gpio_18	-	hsusb1_tll_data4	-
AD2	etk_d5	mcbasp5_fsx	mmc3_dat1	hsusb1_data5	gpio_19	-	hsusb1_tll_data5	-
AC8	etk_d6	mcbasp5_dx	mmc3_dat2	hsusb1_data6	gpio_20	-	hsusb1_tll_data6	-
AD9	etk_d7	mcspi3_cs1	mmc3_dat7	hsusb1_data3	gpio_21	mm1_txen_n	hsusb1_tll_data3	-
AC4	etk_d8	sys_drm_msecure	mmc3_dat6	hsusb1_dir	gpio_22	-	hsusb1_tll_dir	-
AD5	etk_d9	sys_secure_indicator	mmc3_dat5	hsusb1_nxt	gpio_23	mm1_rxdm	hsusb1_tll_nxt	-
AC3	etk_d10	-	uart1_rx	hsusb2_clk	gpio_24	-	hsusb2_tll_clk	-
AC9	etk_d11	-	-	hsusb2_stp	gpio_25	mm2_rxdp	hsusb2_tll_stp	-
AC10	etk_d12	-	-	hsusb2_dir	gpio_26	-	hsusb2_tll_dir	-
AD11	etk_d13	-	-	hsusb2_nxt	gpio_27	mm2_rxdm	hsusb2_tll_nxt	-
AC11	etk_d14	-	-	hsusb2_data0	gpio_28	mm2_rxcv	hsusb2_tll_data0	-
AD12	etk_d15	-	-	hsusb2_data1	gpio_29	mm2_txse0	hsusb2_tll_data1	-

(1) NA in table stands for Not Applicable.

PRODUCT PREVIEW

2.4 Signal Description

Many signals are available on multiple pins according to the software configuration of the pin multiplexing options.

1. **SIGNAL NAME:** The signal name
2. **DESCRIPTION:** Description of the signal
3. **TYPE:** Type = Ball type for this specific function:
 - I = Input
 - O = Output
 - Z = High-impedance
 - D = Open Drain
 - DS = Differential
 - A = Analog
4. **BALL BOTTOM:** Associated ball(s) bottom
5. **BALL TOP:** Associated ball(s) top
6. **SUBSYSTEM PIN MULTIPLEXING:** Contains a list of the pin multiplexing options at the module/subsystem level. The pin function is selected at the module/system level.

Note: The Subsystem Multiplexing Signals are not described in [Table 2-1](#) through [Table 2-4](#).

2.4.1 External Memory Interfaces

Table 2-5. External Memory Interfaces – GPMC Signals Description

SIGNAL NAME [1]	DESCRIPTION [2]	TYPE [3]	BALL BOTTOM (CBB Pkg.) [4]	BALL TOP (CBB Pkg.) [5]	BALL BOTTOM (CUS Pkg.) [4]	SUBSYSTEM PIN MULTIPLEXING [6]
gpmc_a1	General-purpose memory address bit 1	O	N4 / K1	AC15 / M2	K4/ L2	gpmc_a17/ gpmc_d0
gpmc_a2	General-purpose memory address bit 2	O	M4 / L1	AB15 / M1	K3/ M1	gpmc_a18/ gpmc_d1
gpmc_a3	General-purpose memory address bit 3	O	L4 / L2	AC16 / N2	K2/ M2	gpmc_a19/ gpmc_d2
gpmc_a4	General-purpose memory address bit 4	O	K4 / P2	AB16 / N1	J4/ N2	gpmc_a20/ gpmc_d3
gpmc_a5	General-purpose memory address bit 5	O	T3 / T1	AC17 / R2	J3/ M3	gpmc_a21/ gpmc_d4
gpmc_a6	General-purpose memory address bit 6	O	R3 / V1	AB17 / R1	J2/ P1	gpmc_a22/ gpmc_d5
gpmc_a7	General-purpose memory address bit 7	O	N3 / V2	AC18 / T2	J1/ P2	gpmc_a23/ gpmc_d6
gpmc_a8	General-purpose memory address bit 8	O	M3 / W2	AB18 / T1	H1/ R1	gpmc_a24/ gpmc_d7
gpmc_a9	General-purpose memory address bit 9	O	L3 / H2	AC19 / AB3	H2/ R2	gpmc_a25/ gpmc_d8
gpmc_a10	General-purpose memory address bit 10	O	K3 / K2	AB19 / AC3	G2/ T2	gpmc_a26/ gpmc_d9
gpmc_a11	General-purpose memory address bit 11	O	P1	AB4	U1	gpmc_d10
gpmc_a12	General-purpose memory address bit 12	O	R1	AC4	R3	gpmc_d11
gpmc_a13	General-purpose memory address bit 13	O	R2	AB6	T3	gpmc_d12
gpmc_a14	General-purpose memory address bit 14	O	T2	AC6	U2	gpmc_d13
gpmc_a15	General-purpose memory address bit 15	O	W1	AB7	V1	gpmc_d14
gpmc_a16	General-purpose memory address bit 16	O	Y1	AC7	V2	gpmc_d15
gpmc_a17	General-purpose memory address bit 17	O	N4	AC15	K4	gpmc_a1

Table 2-5. External Memory Interfaces – GPMC Signals Description (continued)

SIGNAL NAME [1]	DESCRIPTION [2]	TYPE [3]	BALL BOTTOM (CBB Pkg.) [4]	BALL TOP (CBB Pkg.) [5]	BALL BOTTOM (CUS Pkg.) [4]	SUBSYSTEM PIN MULTIPLEXING [6]
gpmc_a18	General-purpose memory address bit 18	O	M4	AB15	K3	gpmc_a2
gpmc_a19	General-purpose memory address bit 19	O	L4	AC16	K2	gpmc_a3
gpmc_a20	General-purpose memory address bit 20	O	K4	AB16	J4	gpmc_a4
gpmc_a21	General-purpose memory address bit 21	O	T3	AC17	J3	gpmc_a5
gpmc_a22	General-purpose memory address bit 22	O	R3	AB17	J2	gpmc_a6
gpmc_a23	General-purpose memory address bit 23	O	N3	AC18	J1	gpmc_a7
gpmc_a24	General-purpose memory address bit 24	O	M3	AB18	H1	gpmc_a8
gpmc_a25	General-purpose memory address bit 25	O	L3	AC19	H2	gpmc_a9
gpmc_a26	General-purpose memory address bit 26	O	K3	AB19	G2	gpmc_a10
gpmc_d0	GPMC Data bit 0	IO	K1	M2	L2	gpmc_a1/ gpmc_d0
gpmc_d1	GPMC Data bit 1	IO	L1	M1	M1	gpmc_a2/ gpmc_d1
gpmc_d2	GPMC Data bit 2	IO	L2	N2	M2	gpmc_a3/ gpmc_d2
gpmc_d3	GPMC Data bit 3	IO	P2	N1	N2	gpmc_a4/ gpmc_d3
gpmc_d4	GPMC Data bit 4	IO	T1	R2	M3	gpmc_a5/ gpmc_d4
gpmc_d5	GPMC Data bit 5	IO	V1	R1	P1	gpmc_a6/ gpmc_d5
gpmc_d6	GPMC Data bit 6	IO	V2	T2	P2	gpmc_a7 /gpmc_d6
gpmc_d7	GPMC Data bit 7	IO	W2	T1	R1	gpmc_a8/ gpmc_d7
gpmc_d8	GPMC Data bit 8	IO	H2	AB3	R2	gpmc_a9/ gpmc_d8
gpmc_d9	GPMC Data bit 9	IO	K2	AC3	T2	gpmc_a10/ gpmc_d9
gpmc_d10	GPMC Data bit 10	IO	P1	AB4	U1	gpmc_a11/ gpmc_d10
gpmc_d11	GPMC Data bit 11	IO	R1	AC4	R3	gpmc_a12/ gpmc_d11
gpmc_d12	GPMC Data bit 12	IO	R2	AB6	T3	gpmc_a13/ gpmc_d12
gpmc_d13	GPMC Data bit 13	IO	T2	AC6	U2	gpmc_a14/ gpmc_d13
gpmc_d14	GPMC Data bit 14	IO	W1	AB7	V1	gpmc_a15/ gpmc_d14
gpmc_d15	GPMC Data bit 15	IO	Y1	AC7	V2	gpmc_a16/ gpmc_d15
gpmc_ncs0	GPMC Chip Select bit 0	O	G4	Y2	E2	-
gpmc_ncs1	GPMC Chip Select bit 1	O	H3	Y1	NA	-
gpmc_ncs2	GPMC Chip Select bit 2	O	V8	NA	NA	-
gpmc_ncs3	GPMC Chip Select bit 3	O	U8	NA	D2	-
gpmc_ncs4	GPMC Chip Select bit 4	O	T8	NA	F4	-
gpmc_ncs5	GPMC Chip Select bit 5	O	R8	NA	G5	-
gpmc_ncs6	GPMC Chip Select bit 6	O	P8	NA	F3	-
gpmc_ncs7	GPMC Chip Select bit 7	O	N8	NA	G4	-
gpmc_io_dir	GPMC IO direction control for use with external transceivers	O	N8	NA	G4	-
gpmc_clk	GPMC clock	O	T4	W2	W2	-
gpmc_nadv_al e	Address Valid or Address Latch Enable	O	F3	W1	F1	-
gpmc_noe	Output Enable	O	G2	V2	F2	-
gpmc_nwe	Write Enable	O	F4	V1	G3	-

PRODUCT PREVIEW

Table 2-5. External Memory Interfaces – GPMC Signals Description (continued)

SIGNAL NAME [1]	DESCRIPTION [2]	TYPE [3]	BALL BOTTOM (CBB Pkg.) [4]	BALL TOP (CBB Pkg.) [5]	BALL BOTTOM (CUS Pkg.) [4]	SUBSYSTEM PIN MULTIPLEXING [6]
gpmc_nbe0_cle	Lower Byte Enable. Also used for Command Latch Enable	O	G3	AC12	K5	-
gpmc_nbe1	Upper Byte Enable	O	U3	NA	L1	-
gpmc_nwp	Flash Write Protect	O	H1	AB10	E1	-
gpmc_wait0	External indication of wait	I	M8	AB12	C1	-
gpmc_wait1	External indication of wait	I	L8	AC10	NA	-
gpmc_wait2	External indication of wait	I	K8	NA	NA	-
gpmc_wait3	External indication of wait	I	J8	NA	C2	-

Table 2-6. External Memory Interfaces – SDRAM Signals Description

SIGNAL NAME	DESCRIPTION	TYPE ⁽¹⁾	BALL BOTTOM (CBB Pkg.)	BALL TOP (CBB Pkg.)	BALL BOTTOM (CUS Pkg.)
sdrc_d0	SDRAM data bit 0	IO	D6	J2	D7
sdrc_d1	SDRAM data bit 1	IO	C6	J1	C5
sdrc_d2	SDRAM data bit 2	IO	B6	G2	C6
sdrc_d3	SDRAM data bit 3	IO	C8	G1	B5
sdrc_d4	SDRAM data bit 4	IO	C9	F2	D9
sdrc_d5	SDRAM data bit 5	IO	A7	F1	D10
sdrc_d6	SDRAM data bit 6	IO	B9	D2	C7
sdrc_d7	SDRAM data bit 7	IO	A9	D1	B7
sdrc_d8	SDRAM data bit 8	IO	C14	B13	B11
sdrc_d9	SDRAM data bit 9	IO	B14	A13	C12
sdrc_d10	SDRAM data bit 10	IO	C15	B14	B12
sdrc_d11	SDRAM data bit 11	IO	B16	A14	D13
sdrc_d12	SDRAM data bit 12	IO	D17	B16	C13
sdrc_d13	SDRAM data bit 13	IO	C17	A16	B14
sdrc_d14	SDRAM data bit 14	IO	B17	B19	A14
sdrc_d15	SDRAM data bit 15	IO	D18	A19	B15
sdrc_d16	SDRAM data bit 16	IO	D11	B3	C9
sdrc_d17	SDRAM data bit 17	IO	B10	A3	E12
sdrc_d18	SDRAM data bit 18	IO	C11	B5	B8
sdrc_d19	SDRAM data bit 19	IO	D12	A5	B9
sdrc_d20	SDRAM data bit 20	IO	C12	B8	C10
sdrc_d21	SDRAM data bit 21	IO	A11	A8	B10
sdrc_d22	SDRAM data bit 22	IO	B13	B9	D12
sdrc_d23	SDRAM data bit 23	IO	D14	A9	E13
sdrc_d24	SDRAM data bit 24	IO	C18	B21	E15
sdrc_d25	SDRAM data bit 25	IO	A19	A21	D15
sdrc_d26	SDRAM data bit 26	IO	B19	D22	C15
sdrc_d27	SDRAM data bit 27	IO	B20	D23	B16
sdrc_d28	SDRAM data bit 28	IO	D20	E22	C16
sdrc_d29	SDRAM data bit 29	IO	A21	E23	D16
sdrc_d30	SDRAM data bit 30	IO	B21	G22	B17
sdrc_d31	SDRAM data bit 31	IO	C21	G23	B18
sdrc_ba0	SDRAM bank select 0	O	H9	AB21	C18

PRODUCT PREVIEW

Table 2-6. External Memory Interfaces – SDRAM Signals Description (continued)

SIGNAL NAME	DESCRIPTION	TYPE ⁽¹⁾	BALL BOTTOM (CBB Pkg.)	BALL TOP (CBB Pkg.)	BALL BOTTOM (CUS Pkg.)
sdrc_ba1	SDRAM bank select 1	O	H10	AC21	D18
sdrc_a0	SDRAM address bit 0	O	A4	N22	A4
sdrc_a1	SDRAM address bit 1	O	B4	N23	B4
sdrc_a2	SDRAM address bit 2	O	B3	P22	D6
sdrc_a3	SDRAM address bit 3	O	C5	P23	B3
sdrc_a4	SDRAM address bit 4	O	C4	R22	B2
sdrc_a5	SDRAM address bit 5	O	D5	R23	C3
sdrc_a6	SDRAM address bit 6	O	C3	T22	E3
sdrc_a7	SDRAM address bit 7	O	C2	T23	F6
sdrc_a8	SDRAM address bit 8	O	C1	U22	E10
sdrc_a9	SDRAM address bit 9	O	D4	U23	E9
sdrc_a10	SDRAM address bit 10	O	D3	V22	E7
sdrc_a11	SDRAM address bit 11	O	D2	V23	G6
sdrc_a12	SDRAM address bit 12	O	D1	W22	G7
sdrc_a13	SDRAM address bit 13	O	E2	W23	F7
sdrc_a14	SDRAM address bit 14	O	E1	Y22	F9
sdrc_ncs0	Chip select 0	O	H11	M22	A19
sdrc_ncs1	Chip select 1	O	H12	M23	B19
sdrc_clk	Clock	IO	A13	A11	A10
sdrc_nclk	Clock Invert	O	A14	B11	A11
sdrc_cke0	Clock Enable 0	O	H16	J22	B20
sdrc_cke1	Clock Enable 1	O	H17	J23	C20
sdrc_nras	SDRAM Row Access	O	H14	L23	D19
sdrc_ncas	SDRAM column address strobe	O	H13	L22	C19
sdrc_nwe	SDRAM write enable	O	H15	K23	A20
sdrc_dm0	Data Mask 0	O	B7	C1	B6
sdrc_dm1	Data Mask 1	O	A16	A17	B13
sdrc_dm2	Data Mask 2	O	B11	A6	A7
sdrc_dm3	Data Mask 3	O	C20	A20	A16
sdrc_dqs0	Data Strobe 0	IO	A6	C2	A5
sdrc_dqs1	Data Strobe 1	IO	A17	B17	A13
sdrc_dqs2	Data Strobe 2	IO	A10	B6	A8
sdrc_dqs3	Data Strobe 3	IO	A20	B20	A17

(1) Type = Ball type for this specific function (I = Input, O = Output, Z = high-impedance, D = Open Drain, DS = Differential, A = Analog).

PRODUCT PREVIEW

2.4.2 Video Interfaces

Table 2-7. Video Interfaces – CAM Signals Description

SIGNAL NAME	DESCRIPTION	TYPE ⁽¹⁾	BALL BOTTOM (CBB Pkg.)	BALL BOTTOM (CUS Pkg.)
cam_hs	Camera Horizontal Synchronization	IO	A24	A22
cam_vs	Camera Vertical Synchronization	IO	A23	E18
cam_xclka	Camera Clock Output a	O	C25	B22
cam_xclkb	Camera Clock Output b	O	B26	C22
cam_d0	Camera digital image data bit 0	I	AG17	AB18
cam_d1	Camera digital image data bit 1	I	AH17	AC18
cam_d2	Camera digital image data bit 2	I	B24	G19
cam_d3	Camera digital image data bit 3	I	C24	F19
cam_d4	Camera digital image data bit 4	I	D24	G20
cam_d5	Camera digital image data bit 5	I	A25	B21
cam_d6	Camera digital image data bit 6	I	K28	L24
cam_d7	Camera digital image data bit 7	I	L28	K24
cam_d8	Camera digital image data bit 8	I	K27	J23
cam_d9	Camera digital image data bit 9	I	L27	K23
cam_d10	Camera digital image data bit 10	I	B25	F21
cam_d11	Camera digital image data bit 11	I	C26	G21
cam_fld	Camera field identification	IO	C23	H24
cam_pclk	Camera pixel clock	I	C27	J19
cam_wen	Camera Write Enable	I	B23	F18
cam_strobe	Flash strobe control signal	O	D25	J20
cam_global_reset	Global reset is used strobe synchronization	IO	C23 / AH3 / AA21	H24/ AA2/ AB20
cam_shutter	Mechanical shutter control signal	O	B23 / AF3 / T21	F18/ Y2/ AA18

(1) Type = Ball type for this specific function (I = Input, O = Output, Z = high-impedance, D = Open Drain, DS = Differential, A = Analog).

Table 2-8. Video Interfaces – DSS Signals Description

SIGNAL NAME	DESCRIPTION	TYPE ⁽¹⁾	BALL BOTTOM (CBB Pkg.)	BALL BOTTOM (CUS Pkg.)
dss_pclk	LCD Pixel Clock	O	D28	G22
dss_hsync	LCD Horizontal Synchronization	O	D26	E22
dss_vsync	LCD Vertical Synchronization	O	D27	F22
dss_acbias	AC bias control (STN) or pixel data enable (TFT) output	O	E27	J21
dss_data0	LCD Pixel Data bit 0	IO	AG22 / H26	AC19
dss_data1	LCD Pixel Data bit 1	IO	AH22 / H25	AB19
dss_data2	LCD Pixel Data bit 2	IO	AG23 / E28	AD20
dss_data3	LCD Pixel Data bit 3	IO	AH23 / J26	AC20
dss_data4	LCD Pixel Data bit 4	IO	AG24 / AC27	AD21
dss_data5	LCD Pixel Data bit 5	IO	AH24 / AC28	AC21
dss_data6	LCD Pixel Data bit 6	IO	E26	D24
dss_data7	LCD Pixel Data bit 7	IO	F28	E23
dss_data8	LCD Pixel Data bit 8	IO	F27	E24
dss_data9	LCD Pixel Data bit 9	IO	G26	F23
dss_data10	LCD Pixel Data bit 10	IO	AD28	AC22
dss_data11	LCD Pixel Data bit 11	IO	AD27	AC23

Table 2-8. Video Interfaces – DSS Signals Description (continued)

SIGNAL NAME	DESCRIPTION	TYPE ⁽¹⁾	BALL BOTTOM (CBB Pkg.)	BALL BOTTOM (CUS Pkg.)
dss_data12	LCD Pixel Data bit 12	IO	AB28	AB22
dss_data13	LCD Pixel Data bit 13	IO	AB27	Y22
dss_data14	LCD Pixel Data bit 14	IO	AA28	W22
dss_data15	LCD Pixel Data bit 15	IO	AA27	V22
dss_data16	LCD Pixel Data bit 16	IO	G25	J22
dss_data17	LCD Pixel Data bit 17	IO	H27	G23
dss_data18	LCD Pixel Data bit 18	IO	H26	G24
dss_data19	LCD Pixel Data bit 19	IO	H25	H23
dss_data20	LCD Pixel Data bit 20	O	E28	D23
dss_data21	LCD Pixel Data bit 21	O	J26	K22
dss_data22	LCD Pixel Data bit 22	O	AC27	V21
dss_data23	LCD Pixel Data bit 23	O	AC28	W21

(1) Type = Ball type for this specific function (I = Input, O = Output, Z = high-impedance, D = Open Drain, DS = Differential, A = Analog).

Table 2-9. Video Interfaces – RFBI Signals Description

SIGNAL NAME	DESCRIPTION	TYPE ⁽¹⁾	BALL BOTTOM (CBB Pkg.)	BALL BOTTOM (CUS Pkg.)	SUBSYSTEM PIN MULTIPLEXING ⁽²⁾
rfbi_a0	RFBI command/data control	O	E27	J21	dss_acbias
rfbi_cs0	1st LCD chip select	O	D26	E22	dss_hsync
rfbi_da0	RFBI data bus 0	IO	AG22	AC19	dss_data0
rfbi_da1	RFBI data bus 1	IO	AH22	AB19	dss_data1
rfbi_da2	RFBI data bus 2	IO	AG23	AD20	dss_data2
rfbi_da3	RFBI data bus 3	IO	AH23	AC20	dss_data3
rfbi_da4	RFBI data bus 4	IO	AG24	AD21	dss_data4
rfbi_da5	RFBI data bus 5	IO	AH24	AC21	dss_data5
rfbi_da6	RFBI data bus 6	IO	E26	D24	dss_data6
rfbi_da7	RFBI data bus 7	IO	F28	E23	dss_data7
rfbi_da8	RFBI data bus 8	IO	F27	E24	dss_data8
rfbi_da9	RFBI data bus 9	IO	G26	F23	dss_data9
rfbi_da10	RFBI data bus 10	IO	AD28	AC22	dss_data10
rfbi_da11	RFBI data bus 11	IO	AD27	AC23	dss_data11
rfbi_da12	RFBI data bus 12	IO	AB28	AB22	dss_data12
rfbi_da13	RFBI data bus 13	IO	AB27	Y22	dss_data13
rfbi_da14	RFBI data bus 14	IO	AA28	W22	dss_data14
rfbi_da15	RFBI data bus 15	IO	AA27	V22	dss_data15
rfbi_rd	Read enable for RFBI	O	D28	G22	dss_pclk
rfbi_wr	Write Enable for RFBI	O	D27	F22	dss_vsync
rfbi_te_vsync0	tearing effect removal and Vsync input from 1st LCD	I	G25	J22	dss_data16
rfbi_hsync0	Hsync for 1st LCD	I	H27	G23	dss_data17

(1) Type = Ball type for this specific function (I = Input, O = Output, Z = high-impedance, D = Open Drain, DS = Differential, A = Analog).

(2) The subsystem pin multiplexing options are not described in [Table 2-1](#) and [Table 2-3](#).

Table 2-10. Video Interfaces – TV Signals Description

SIGNAL NAME	DESCRIPTION	TYPE ⁽¹⁾	BALL BOTTOM (CBB Pkg.)	BALL BOTTOM (CUS Pkg.)
tv_out1	TV analog output Composite: tv_out1	O	Y28	AB24
tv_out2	TV analog output S-VIDEO: tv_out2	O	W28	AA23
tv_vfb1	tv_vfb1: Feedback through external resistor to composite	O	Y27	AB23
tv_vfb2	tv_vfb2: Feedback through external resistor to S-VIDEO	O	W27	Y23
tv_vref	External capacitor	I	W26	Y24

(1) Type = Ball type for this specific function (I = Input, O = Output, Z = high-impedance, D = Open Drain, DS = Differential, A = Analog).

2.4.3 Serial Communication Interfaces

Table 2-11. Serial Communication Interfaces – HDQ/1-Wire Signals Description

SIGNAL NAME	DESCRIPTION	TYPE ⁽¹⁾	BALL BOTTOM (CBB Pkg.)	BALL BOTTOM (CUS Pkg.)
hdq_sio	Bidirectional HDQ 1-Wire control and data Interface. Output is open drain.	IOD	J25	A24

1. Type = Ball type for this specific function (I = Input, O = Output, Z = high-impedance, D = Open Drain, DS = Differential, A = Analog).

Table 2-12. Serial Communication Interfaces – I²C Signals Description

SIGNAL NAME	DESCRIPTION	TYPE ⁽¹⁾	BALL BOTTOM (CBB Pkg.)	BALL BOTTOM (CUS Pkg.)
INTER-INTEGRATED CIRCUIT INTERFACE (I2C1)				
i2c1_scl	I ² C Master Serial clock. Output is open drain.	IOD	K21	K20
i2c1_sda	I ² C Serial Bidirectional Data. Output is open drain.	IOD	J21	K21
INTER-INTEGRATED CIRCUIT INTERFACE (I2C3)				
i2c3_scl	I ² C Master Serial clock. Output is open drain.	IOD	AF14	AC13
i2c3_sda	I ² C Serial Bidirectional Data. Output is open drain.	IOD	AG14	AC12
i2c3_sccbe	TBD	O	J25	A24
INTER-INTEGRATED CIRCUIT INTERFACE (I2C2)				
i2c2_scl	I ² C Master Serial clock. Output is open drain.	IOD	AF15	AC15
i2c2_sda	I ² C Serial Bidirectional Data. Output is open drain.	IOD	AE15	AC14
i2c2_sccbe	TBD	O	J25	A24
i2c4_scl	I ² C Master Serial clock. Output is open drain.	IOD	AD26	Y16
i2c4_sda	I ² C Serial Bidirectional Data. Output is open drain.	IOD	AE26	Y15

(1) Type = Ball type for this specific function (I = Input, O = Output, Z = high-impedance, D = Open Drain, DS = Differential, A = Analog).

Table 2-13. Serial Communication Interfaces – McBSP LP Signals Description

SIGNAL NAME	DESCRIPTION	TYPE ⁽¹⁾	BALL BOTTOM (CBB Pkg.)	BALL BOTTOM (CUS Pkg.)
MULTICHANNEL SERIAL (McBSP LP 1)				
mcbasp1_dr	Received serial data	I	U21	Y18
mcbasp1_clk	Receive Clock	IO	Y8 / Y21	V7 / W19
mcbasp1_fsr	Receive frame synchronization	IO	AA21	AB20
mcbasp1_dx	Transmitted serial data	IO	V21	W18
mcbasp1_clkx	Transmit clock	IO	W21	V18
mcbasp1_fsx	Transmit frame synchronization	IO	K26	AA19
mcbasp_clks	External clock input (shared by McBSP1, 2, 3, 4, and 5)	I	T21	AA18
MULTICHANNEL SERIAL (McBSP LP 2)				
mcbasp2_dr	Received serial data	I	R21	V19
mcbasp2_dx	Transmitted serial data	IO	M21	R20
mcbasp2_clkx	Combined serial clock	IO	N21	T2

Table 2-13. Serial Communication Interfaces – McBSP LP Signals Description (continued)

SIGNAL NAME	DESCRIPTION	TYPE ⁽¹⁾	BALL BOTTOM (CBB Pkg.)	BALL BOTTOM (CUS Pkg.)
mcbasp2_fsx	Combined frame synchronization	IO	P21	V20
MULTICHANNEL SERIAL (McBSP LP 3)				
mcbasp3_dr	Received serial data	I	AE6 / AB25 / U21	V5 / Y18
mcbasp3_dx	Transmitted serial data	IO	AF6 / AB26 / V21	V6 / W18
mcbasp3_clkx	Combined serial clock	IO	AF5 / AA25 / W21	W4 / V18
mcbasp3_fsx	Combined frame synchronization	IO	AE5 / AD25 / K26	V4 / AA19
MULTICHANNEL SERIAL (McBSP LP 4)				
mcbasp4_dr	Received serial data	I	R8 / AD1	G5
mcbasp4_dx	Transmitted serial data	IO	P8 / AD2	F3
mcbasp4_clkx	Combined serial clock	IO	T8 / AE1	F4
mcbasp4_fsx	Combined frame synchronization	IO	N8 / AC1	G4
MULTICHANNEL SERIAL (McBSP LP 5)				
mcbasp5_dr	Received serial data	I	AE11	AC5
mcbasp5_dx	Transmitted serial data	IO	AF13	AC8
mcbasp5_clkx	Combined serial clock	IO	AF10	AC1
mcbasp5_fsx	Combined frame synchronization	IO	AH9	AD2

(1) Type = Ball type for this specific function (I = Input, O = Output, Z = high-impedance, D = Open Drain, DS = Differential, A = Analog)

Table 2-14. Serial Communication Interfaces – McSPI Signals Description

SIGNAL NAME	DESCRIPTION	TYPE ⁽¹⁾	BALL BOTTOM (CBB Pkg.)	BALL BOTTOM (CUS Pkg.)
MULTICHANNEL SERIAL PORT INTERFACE (McSPI1)				
mcspi1_clk	SPI Clock	IO	AB3	T5
mcspi1_simo	Slave data in, master data out	IO	AB4	R4
mcspi1_somi	Slave data out, master data in	IO	AA4	T4
mcspi1_cs0	SPI Enable 0, polarity configured by software	IO	AC2	T6
mcspi1_cs1	SPI Enable 1, polarity configured by software	O	AC3	NA
mcspi1_cs2	SPI Enable 2, polarity configured by software	O	AB1	NA
mcspi1_cs3	SPI Enable 3, polarity configured by software	O	AB2	R5
MULTICHANNEL SERIAL PORT INTERFACE (McSPI2)				
mcspi2_clk	SPI Clock	IO	AA3	N5
mcspi2_simo	Slave data in, master data out	IO	Y2	N4
mcspi2_somi	Slave data out, master data in	IO	Y3	N3
mcspi2_cs0	SPI Enable 0, polarity configured by software	IO	Y4	M5
mcspi2_cs1	SPI Enable 1, polarity configured by software	O	V3	M4
MULTICHANNEL SERIAL PORT INTERFACE (McSPI3)				
mcspi3_clk	SPI Clock	IO	H26 / AE2 / AE13	G24 / Y1 / AD8
mcspi3_simo	Slave data in, master data out	IO	H25 / AG5 / AF11	H23 / AB5 / AD6
mcspi3_somi	Slave data out, master data in	IO	E28 / AH5 / AG12	D23 / AB3 / AC6
mcspi3_cs0	SPI Enable 0, polarity configured by software	IO	J26 / AF4 / AH12	K22 / V3 / AC7
mcspi3_cs1	SPI Enable 1, polarity configured by software	O	AC27 / AG4 / AH14	V21 / W3 / AD9

Table 2-14. Serial Communication Interfaces – McSPI Signals Description (continued)

SIGNAL NAME	DESCRIPTION	TYPE ⁽¹⁾	BALL BOTTOM (CBB Pkg.)	BALL BOTTOM (CUS Pkg.)
MULTICHANNEL SERIAL PORT INTERFACE (McSPI4)				
mcspi4_clk	SPI Clock	IO	Y8 / Y21	V7 / W19
mcspi4_simo	Slave data in, master data out	IO	V21	W18
mcspi4_somi	Slave data out, master data in	IO	U21	Y18
mcspi4_cs0	SPI Enable 0, polarity configured by software	IO	K26	AA19

(1) Type = Ball type for this specific function (I = Input, O = Output, Z = high-impedance, D = Open Drain, DS = Differential, A = Analog)

Table 2-15. Serial Communication Interfaces – UARTs Signals Description

SIGNAL NAME	DESCRIPTION	TYPE ⁽¹⁾	BALL BOTTOM (CBB Pkg.)	BALL BOTTOM (CUS Pkg.)
UNIVERSAL ASYNCHRONOUS RECEIVER/TRANSMITTER (UART1)				
uart1_cts	UART1 Clear To Send	I	AG22 / W8 / T21	AC19 / AC2 / AA18
uart1_rts	UART1 Request To Send	O	AH22 / AA9	W6 / AB19
uart1_rx	UART1 Receive data	I	F28 / Y8 / AE7	E23 / V7 / AC3
uart1_tx	UART1 Transmit data	O	E26 / AA8	D24 / W7
UNIVERSAL ASYNCHRONOUS RECEIVER/TRANSMITTER (UART2)				
uart2_cts	UART2 Clear To Send	I	AF6 / AB26	V6
uart2_rts	UART2 Request To Send	O	AE6 / AB25	V5
uart2_rx	UART2 Receive data	I	AE5 / AD25	V4
uart2_tx	UART2 Transmit data	O	AF5 / AA25	W4
UNIVERSAL ASYNCHRONOUS RECEIVER/TRANSMITTER (UART3) / IrDA				
uart3_cts_rctx	UART3 Clear To Send (input), Remote TX (output)	IO	H18 / U26	A23 / U23
uart3_rts_sd	UART3 Request To Send, IR enable	O	H19 / U27	B23 / U24
uart3_rx_irrx	UART3 Receive data, IR and Remote RX	I	AG24 / H20 / U28	AD21 / B24 / T23
uart3_tx_irtx	UART3 Transmit data, IR TX	O	AH24 / H21 / T27	AC21 / C23 / T24

(1) Type = Ball type for this specific function (I = Input, O = Output, Z = high-impedance, D = Open Drain, DS = Differential, A = Analog)

Table 2-16. Serial Communication Interfaces – USB Signals Description

SIGNAL NAME	DESCRIPTION	TYPE ⁽¹⁾	BALL BOTTOM (CBB Pkg.)	BALL BOTTOM (CUS Pkg.)
HIGH-SPEED UNIVERSAL SERIAL BUS INTERFACE (HSUSB0)				
hsusb0_clk	Dedicated for external transceiver 60-MHz clock input from PHY	I	T28	R21
hsusb0_stp	Dedicated for external transceiver Stop signal	O	T25	R23
hsusb0_dir	Dedicated for external transceiver Data direction control from PHY	I	R28	P23
hsusb0_nxt	Dedicated for external transceiver Next signal from PHY	I	T26	R22
hsusb0_data0	Dedicated for external transceiver Bidirectional data bus	IO	T27	T24
hsusb0_data1	Dedicated for external transceiver Bidirectional data bus	IO	U28	T23
hsusb0_data2	Dedicated for external transceiver Bidirectional data bus	IO	U27	U24
hsusb0_data3	Dedicated for external transceiver Bidirectional data bus	IO	U26	U23
hsusb0_data4	Dedicated for external transceiver Bidirectional data bus additional signals for 12-pin ULPI operation	IO	U25	W24
hsusb0_data5	Dedicated for external transceiver Bidirectional data bus additional signals for 12-pin ULPI operation	IO	V28	V23

Table 2-16. Serial Communication Interfaces – USB Signals Description (continued)

SIGNAL NAME	DESCRIPTION	TYPE ⁽¹⁾	BALL BOTTOM (CBB Pkg.)	BALL BOTTOM (CUS Pkg.)
hsusb0_data6	Dedicated for external transceiver Bidirectional data bus additional signals for 12-pin ULPI operation	IO	V27	W23
hsusb0_data7	Dedicated for external transceiver Bidirectional data bus additional signals for 12-pin ULPI operation	IO	V26	T22
MM_FSUSB3				
mm3_rxdm	Vminus receive data (not used in 3- or 4-pin configurations)	IO	AE3	NA
mm3_rxdp	Vplus receive data (not used in 3- or 4-pin configurations)	IO	AH3	NA
mm3_rxcv	Differential receiver signal input (not used in 3-pin mode)	IO	AD1	NA
mm3_txse0	Single-ended zero. Used as VM in 4-pin VP_VM mode.	IO	AE1	NA
mm3_txdat	USB data. Used as VP in 4-pin VP_VM mode.	IO	AD2	NA
mm3_txen_n	Transmit enable	IO	AC1	NA
MM_FSUSB2				
mm2_rxdm	Vminus receive data (not used in 3- or 4-pin configurations)	IO	AH7	AD11
mm2_rxdp	Vplus receive data (not used in 3- or 4-pin configurations)	IO	AF7	AC9
mm2_rxcv	Differential receiver signal input (not used in 3-pin mode)	IO	AG8	AC11
mm2_txse0	Single-ended zero. Used as VM in 4-pin VP_VM mode.	IO	AH8	AD12
mm2_txdat	USB data. Used as VP in 4-pin VP_VM mode.	IO	AB2	R5
mm2_txen_n	Transmit enable	IO	V3	M4
MM_FSUSB1				
mm1_rxdm	Vminus receive data (not used in 3- or 4-pin configurations)	IO	AG9	AD5
mm1_rxdp	Vplus receive data (not used in 3- or 4-pin configurations)	IO	AF10	AC1
mm1_rxcv	Differential receiver signal input (not used in 3-pin mode)	IO	AF11	AD6
mm1_txse0	Single-ended zero. Used as VM in 4-pin VP_VM mode.	IO	AG12	AC6
mm1_txdat	USB data. Used as VP in 4-pin VP_VM mode.	IO	AH12	AC7
mm1_txen_n	Transmit enable	IO	AH14	AD9
HSUSB3_TLL				
hsusb3_tll_clk	Dedicated for external transceiver 60-MHz clock input from PHY	O	W8	NA
hsusb3_tll_stp	Dedicated for external transceiver Stop signal	I	AH3	NA
hsusb3_tll_dir	dedicated for external transceiver Data direction control from PHY	O	AF3	NA
hsusb3_tll_nxt	Dedicated for external transceiver Next signal from PHY	O	AE3	NA
hsusb3_tll_data0	Dedicated for external transceiver Bidirectional data bus	IO	AD1	NA
hsusb3_tll_data1	Dedicated for external transceiver Bidirectional data bus	IO	AE1	NA
hsusb3_tll_data2	Dedicated for external transceiver Bidirectional data bus	IO	AD2	NA
hsusb3_tll_data3	Dedicated for external transceiver Bidirectional data bus	IO	AC1	NA
hsusb3_tll_data4	Dedicated for external transceiver Bidirectional data bus	IO	AF6	NA
hsusb3_tll_data5	Dedicated for external transceiver Bidirectional data bus	IO	AE6	NA
hsusb3_tll_data6	Dedicated for external transceiver Bidirectional data bus	IO	AF5	NA
hsusb3_tll_data7	Dedicated for external transceiver Bidirectional data bus	IO	AE5	NA
HSUSB2				
hsusb2_clk	Dedicated for external transceiver 60-MHz clock input from PHY	O	AE7	AC3
hsusb2_stp	Dedicated for external transceiver Stop signal	O	AF7	AC9
hsusb2_dir	Dedicated for external transceiver Data direction control from PHY	I	AG7	AC10
hsusb2_nxt	Dedicated for external transceiver Next signal from PHY	I	AH7	AD11
hsusb2_data0	Dedicated for external transceiver Bidirectional data bus	IO	AG8	AC11

PRODUCT PREVIEW

Table 2-16. Serial Communication Interfaces – USB Signals Description (continued)

SIGNAL NAME	DESCRIPTION	TYPE ⁽¹⁾	BALL BOTTOM (CBB Pkg.)	BALL BOTTOM (CUS Pkg.)
hsusb2_data1	Dedicated for external transceiver Bidirectional data bus	IO	AH8	AD12
hsusb2_data2	Dedicated for external transceiver Bidirectional data bus	IO	AB2	R5
hsusb2_data3	Dedicated for external transceiver Bidirectional data bus	IO	V3	M4
hsusb2_data4	Dedicated for external transceiver Bidirectional data bus additional signals for 12-pin ULPI operation	IO	Y2	N4
hsusb2_data5	Dedicated for external transceiver Bidirectional data bus additional signals for 12-pin ULPI operation	IO	Y3	N3
hsusb2_data6	Dedicated for external transceiver Bidirectional data bus additional signals for 12-pin ULPI operation	IO	Y4	M5
hsusb2_data7	Dedicated for external transceiver Bidirectional data bus additional signals for 12-pin ULPI operation	IO	AA3	N5
HSUSB2_TLL				
hsusb2_tll_clk	Dedicated for external transceiver 60-MHz clock input from PHY	O	AE7	AC3
hsusb2_tll_stp	Dedicated for external transceiver Stop signal	I	AF7	AC9
hsusb2_tll_dir	Dedicated for external transceiver data direction control from PHY	O	AG7	AC10
hsusb2_tll_nxt	Dedicated for external transceiver Next signal from PHY	O	AH7	AD11
hsusb2_tll_data0	Dedicated for external transceiver Bidirectional data bus	IO	AG8	AC11
hsusb2_tll_data1	Dedicated for external transceiver Bidirectional data bus	IO	AH8	AD12
hsusb2_tll_data2	Dedicated for external transceiver Bidirectional data bus	IO	AB2	R5
hsusb2_tll_data3	Dedicated for external transceiver Bidirectional data bus	IO	V3	M4
hsusb2_tll_data4	Dedicated for external transceiver Bidirectional data bus additional signals for 12-pin ULPI operation	IO	Y2	N4
hsusb2_tll_data5	Dedicated for external transceiver Bidirectional data bus additional signals for 12-pin ULPI operation	IO	Y3	N3
hsusb2_tll_data6	Dedicated for external transceiver Bidirectional data bus additional signals for 12-pin ULPI operation	IO	Y4	M5
hsusb2_tll_data7	Dedicated for external transceiver Bidirectional data bus additional signals for 12-pin ULPI operation	IO	AA3	N5
HSUSB1				
hsusb1_clk	Dedicated for external transceiver 60-MHz clock input from PHY	O	AE10	AD3
hsusb1_stp	Dedicated for external transceiver Stop signal	O	AF10	AC1
hsusb1_dir	Dedicated for external transceiver data direction control from PHY	I	AF9	AC4
hsusb1_nxt	Dedicated for external transceiver Next signal from PHY	I	AG9	AD5
hsusb1_data0	Dedicated for external transceiver Bidirectional data bus	IO	AF11	AD6
hsusb1_data1	Dedicated for external transceiver Bidirectional data bus	IO	AG12	AC6
hsusb1_data2	Dedicated for external transceiver Bidirectional data bus	IO	AH12	AC7
hsusb1_data3	Dedicated for external transceiver Bidirectional data bus	IO	AH14	AD9
hsusb1_data4	Dedicated for external transceiver Bidirectional data bus additional signals for 12-pin ULPI operation	IO	AE11	AC5
hsusb1_data5	Dedicated for external transceiver Bidirectional data bus additional signals for 12-pin ULPI operation	IO	AH9	AD2
hsusb1_data6	Dedicated for external transceiver Bidirectional data bus additional signals for 12-pin ULPI operation	IO	AF13	AC8
hsusb1_data7	Dedicated for external transceiver Bidirectional data bus additional signals for 12-pin ULPI operation	IO	AE13	AD8
HSUSB1_TLL				
hsusb1_tll_clk	Dedicated for external transceiver 60-MHz clock input from PHY	O	AE10	AD3

PRODUCT PREVIEW

Table 2-16. Serial Communication Interfaces – USB Signals Description (continued)

SIGNAL NAME	DESCRIPTION	TYPE ⁽¹⁾	BALL BOTTOM (CBB Pkg.)	BALL BOTTOM (CUS Pkg.)
hsusb1_tll_stp	Dedicated for external transceiver Stop signal	I	AF10	AC1
hsusb1_tll_dir	Dedicated for external transceiver data direction control from PHY	O	AF9	AC4
hsusb1_tll_nxt	Dedicated for external transceiver Next signal from PHY	O	AG9	AD5
hsusb1_tll_data0	Dedicated for external transceiver Bidirectional data bus	IO	AF11	AD6
hsusb1_tll_data1	Dedicated for external transceiver Bidirectional data bus	IO	AG12	AC6
hsusb1_tll_data2	Dedicated for external transceiver Bidirectional data bus	IO	AH12	AC7
hsusb1_tll_data3	Dedicated for external transceiver Bidirectional data bus	IO	AH14	AD9
hsusb1_tll_data4	Dedicated for external transceiver Bidirectional data bus additional signals for 12-pin ULPI operation	IO	AE11	AC5
hsusb1_tll_data5	Dedicated for external transceiver Bidirectional data bus additional signals for 12-pin ULPI operation	IO	AH9	AD2
hsusb1_tll_data6	Dedicated for external transceiver Bidirectional data bus additional signals for 12-pin ULPI operation	IO	AF13	AC8
hsusb1_tll_data7	Dedicated for external transceiver Bidirectional data bus additional signals for 12-pin ULPI operation	IO	AE13	AD8

(1) Type = Ball type for this specific function (I = Input, O = Output, Z = high-impedance, D = Open Drain, DS = Differential, A = Analog)

PRODUCT PREVIEW

2.4.4 Removable Media Interfaces

Table 2-17. Removable Media Interfaces – MMC/SDIO Signals Description

SIGNAL NAME	DESCRIPTION	TYPE ⁽¹⁾	BALL BOTTOM (CBB Pkg.)	BALL BOTTOM (CUS Pkg.)
MULTIMEDIA MEMORY CARD (MMC1) / SECURE DIGITAL IO (SDIO1)				
mmc1_clk	MMC/SD Output Clock	O	N28	M23
mmc1_cmd	MMC/SD command signal	IO	M27	L23
mmc1_dat0	MMC/SD Card Data bit 0 / SPI Serial Input	IO	N27	M22
mmc1_dat1	MMC/SD Card Data bit 1	IO	N26	M21
mmc1_dat2	MMC/SD Card Data bit 2	IO	N25	M20
mmc1_dat3	MMC/SD Card Data bit 3	IO	P28	N23
mmc1_dat4	MMC/SD Card Data bit 4	IO	P27	N22
mmc1_dat5	MMC/SD Card Data bit 5	IO	P26	N21
mmc1_dat6	MMC/SD Card Data bit 6	IO	R27	N20
mmc1_dat7	MMC/SD Card Data bit 7	IO	R25	P24
MULTIMEDIA MEMORY CARD (MMC2) / SECURE DIGITAL IO (SDIO2)				
mmc2_clk	MMC/SD Output Clock	O	AE2	Y1
mmc2_dir_dat0	Direction control for DAT0 signal case an external transceiver used	O	AE4	AB2
mmc2_dir_dat1	Direction control for DAT1 and DAT3 signals case an external transceiver used	O	AH3	AA2
mmc2_dir_dat2	Direction control for DAT2 signal case an external transceiver used	O	AF19	AC17
mmc2_dir_dat3	Direction control for DAT4, DAT5, DAT6, and DAT7 signals case an external transceiver used	O	AE21	AB16
mmc2_clkln	MMC/SD input Clock	I	AE3	AA1
mmc2_dat0	MMC/SD Card Data bit 0	IO	AH5	AB3
mmc2_dat1	MMC/SD Card Data bit 1	IO	AH4	Y3
mmc2_dat2	MMC/SD Card Data bit 2	IO	AG4	W3
mmc2_dat3	MMC/SD Card Data bit 3	IO	AF4	V3
mmc2_dat4	MMC/SD Card Data bit 4	IO	AE4 / AB3	AB2 / T5
mmc2_dat5	MMC/SD Card Data bit 5	IO	AH3 / AB4	AA2 / R4
mmc2_dat6	MMC/SD Card Data bit 6	IO	AF3 / AA4	Y2 / T4
mmc2_dat7	MMC/SD Card Data bit 7	IO	AE3 / AC2	AA1 / T6
mmc2_dir_cmd	Direction control for CMD signal case an external transceiver is used	O	AF3	Y2
mmc2_cmd	MMC/SD command signal	IO	AG5	AB5
MULTIMEDIA MEMORY CARD (MMC3) / SECURE DIGITAL IO (SDIO3)				
mmc3_clk	MMC/SD Output Clock	O	AB1 / AF10	AC1
mmc3_cmd	MMC/SD command signal	IO	AC3 / AE10	AD3
mmc3_dat0	MMC/SD Card Data bit 0 / SPI Serial Input	IO	AE4 / AE11	AB2 / AC5
mmc3_dat1	MMC/SD Card Data bit 1	IO	AH3 / AH9	AA2 / AD2
mmc3_dat2	MMC/SD Card Data bit 2	IO	AF3 / AF13	Y2 / AC8
mmc3_dat3	MMC/SD Card Data bit 3	IO	AE3 / AE13	AA1 / AD8
mmc3_dat4	MMC/SD Card Data bit 4	IO	AF11	AD6
mmc3_dat5	MMC/SD Card Data bit 5	IO	AG9	AD5
mmc3_dat6	MMC/SD Card Data bit 6	IO	AF9	AC4
mmc3_dat7	MMC/SD Card Data bit 7	IO	AH14	AD9

(1) Type = Ball type for this specific function (I = Input, O = Output, Z = high-impedance, D = Open Drain, DS = Differential, A = Analog)

PRODUCT PREVIEW

2.4.5 Test Interfaces

Table 2-18. Test Interfaces – ETK Signals Description

SIGNAL NAME	DESCRIPTION	TYPE ⁽¹⁾	BALL BOTTOM (CBB Pkg.)	BALL BOTTOM (CUS Pkg.)
etk_ctl	ETK trace ctl	O	AE10	AD3
etk_clk	ETK trace clock	O	AF10	AC1
etk_d0	ETK data 0	O	AF11	AD6
etk_d1	ETK data 1	O	AG12	AC6
etk_d2	ETK data 2	O	AH12	AC7
etk_d3	ETK data 3	O	AE13	AD8
etk_d4	ETK data 4	O	AE11	AC5
etk_d5	ETK data 5	O	AH9	AD2
etk_d6	ETK data 6	O	AF13	AC8
etk_d7	ETK data 7	O	AH14	AD9
etk_d8	ETK data 8	O	AF9	AC4
etk_d9	ETK data 9	O	AG9	AD5
etk_d10	ETK data 10	O	AE7	AC3
etk_d11	ETK data 11	O	AF7	AC9
etk_d12	ETK data 12	O	AG7	AC10
etk_d13	ETK data 13	O	AH7	AD11
etk_d14	ETK data 14	O	AG8	AC11
etk_d15	ETK data 15	O	AH8	AD12

(1) Type = Ball type for this specific function (I = Input, O = Output, Z = high-impedance, D = Open Drain, DS = Differential, A = Analog)

Table 2-19. Test Interfaces – JTAG Signals Description

SIGNAL NAME	DESCRIPTION	TYPE ⁽¹⁾	BALL BOTTOM (CBB Pkg.)	BALL BOTTOM (CUS Pkg.)
jtag_nrst	Test Reset	I	AA17	AB7
jtag_tck	Test Clock	I	AA13	AB6
jtag_rtck	ARM Clock Emulation	O	AA12	AA7
jtag_tms_tmsc	Test Mode Select	IO	AA18	AA9
jtag_tdi	Test Data Input	I	AA20	AB10
jtag_tdo	Test Data Output	O	AA19	AB9
jtag_emu0	Test emulation 0	IO	AA11	AC24
jtag_emu1	Test emulation 1	IO	AA10	AD24

(1) Type = Ball type for this specific function (I = Input, O = Output, Z = high-impedance, D = Open Drain, DS = Differential, A = Analog)

Table 2-20. Test Interfaces – SDTI Signals Description

SIGNAL NAME	DESCRIPTION	TYPE ⁽¹⁾	BALL BOTTOM (CBB Pkg.)	BALL BOTTOM (CUS Pkg.)	SUBSYSTEM SIGNAL MULTIPLEXING ⁽²⁾
sdti_clk	Serial clock dual edge	O	AF7 / AA11 / AG8	AC9 / AC24 / AC11	etk_d11 / jtag_emu0 / etk_d14
sdti_txd0	Serial data out (System Trace messages)	O	AG7 / AA10 / AA11	AC10 / AD24 / AC24	etk_d12 / jtag_emu1 / jtag_emu0
sdti_txd1	Serial data out (System Trace messages)	O	AH7 / AA10	AD11 / AD24	etk_d13 / jtag_emu1
sdti_txd2	Serial data out (System Trace messages)	O	AG8	AC11	etk_d14
sdti_txd3	Serial data out (System Trace messages)	O	AH8	AD12	etk_d15

(1) Type = Ball type for this specific function (I = Input, O = Output, Z = high-impedance, D = Open Drain, DS = Differential, A = Analog)

(2) The subsystem pin multiplexing options are not described in [Table 2-1](#) and [Table 2-3](#)

2.4.6 Miscellaneous

Table 2-21. Miscellaneous – GP Timer Signals Description

SIGNAL NAME	DESCRIPTION	TYPE ⁽¹⁾	BALL BOTTOM (CBB Pkg.)	BALL BOTTOM (CUS Pkg.)
gpt8_pwm_evt	PWM or event for GP timer 8	IO	N8 / AD25 / V3	G4 / M4
gpt9_pwm_evt	PWM or event for GP timer 9	IO	T8 / AB26 / Y2	F4 / N4
gpt10_pwm_evt	PWM or event for GP timer 10	IO	R8 / AB25 / Y3	G5 / N3
gpt11_pwm_evt	PWM or event for GP timer 11	IO	P8 / AA25 / Y4	F3 / M5

(1) Type = Ball type for this specific function (I = Input, O = Output, Z = high-impedance, D = Open Drain, DS = Differential, A = Analog)

2.4.7 General-Purpose IOs

Table 2-22. General-Purpose IOs Signals Description⁽²⁾

SIGNAL NAME	DESCRIPTION	TYPE ⁽¹⁾	BALL BOTTOM (CBB Pkg.)	BALL BOTTOM (CUS Pkg.)
gpio_0	General-purpose IO 0	IO	AF26	W16
gpio_1	General-purpose IO 1	IO	AF25	Y13
gpio_2	General-purpose IO 2	IO	AH26	AB12
gpio_3	General-purpose IO 3	IO	AG26	AC16
gpio_4	General-purpose IO 4	IO	AE14	AD17
gpio_5	General-purpose IO 5	IO	AF18	AD18
gpio_6	General-purpose IO 6	IO	AF19	AC17
gpio_7	General-purpose IO 7	IO	AE21	AB16
gpio_8	General-purpose IO 8	IO	AF21	AA15
gpio_9	General-purpose IO 9	IO	AF22	AD23
gpio_10	General-purpose IO 10	IO	AG25	Y7
gpio_11	General-purpose IO 11	IO	AA11	AC24
gpio_12	General-purpose IO 12	IO	AF10	AC1
gpio_13	General-purpose IO 13	IO	AE10	AD3
gpio_14	General-purpose IO 14	IO	AF11	AD6
gpio_15	General-purpose IO 15	IO	AG12	AC6
gpio_16	General-purpose IO 16	IO	AH12	AC7
gpio_17	General-purpose IO 17	IO	AE13	AD8
gpio_18	General-purpose IO 18	IO	AE11	AC5
gpio_19	General-purpose IO 19	IO	AH9	AD2
gpio_20	General-purpose IO 20	IO	AF13	AC8
gpio_21	General-purpose IO 21	IO	AH14	AD9
gpio_22	General-purpose IO 22	IO	AF9	AC4
gpio_23	General-purpose IO 23	IO	AG9	AD5
gpio_24	General-purpose IO 24	IO	AE7	AC3
gpio_25	General-purpose IO 25	IO	AF7	AC9
gpio_26	General-purpose IO 26	IO	AG7	AC10
gpio_27	General-purpose IO 27	IO	AH7	AD11
gpio_28	General-purpose IO 28	IO	AG8	AC11
gpio_29	General-purpose IO 29	IO	AH8	AD12
gpio_30	General-purpose IO 30	IO	AF24	Y10
gpio_31	General-purpose IO 31	IO	AA10	AD24
gpio_34	General-purpose IO 34	IO	N4	K4
gpio_35	General-purpose IO 35	IO	M4	K3
gpio_36	General-purpose IO 36	IO	L4	K2
gpio_37	General-purpose IO 37	IO	K4	J4
gpio_38	General-purpose IO 38	IO	T3	J3
gpio_39	General-purpose IO 39	IO	R3	J2
gpio_40	General-purpose IO 40	IO	N3	J1
gpio_41	General-purpose IO 41	IO	M3	H1
gpio_42	General-purpose IO 42	IO	L3	H2
gpio_43	General-purpose IO 43	IO	K3	G2
gpio_44	General-purpose IO 44	IO	H2	R2
gpio_45	General-purpose IO 45	IO	K2	T2

PRODUCT PREVIEW

Table 2-22. General-Purpose IOs Signals Description⁽²⁾ (continued)

SIGNAL NAME	DESCRIPTION	TYPE ⁽¹⁾	BALL BOTTOM (CBB Pkg.)	BALL BOTTOM (CUS Pkg.)
gpio_46	General-purpose IO 46	IO	P1	U1
gpio_47	General-purpose IO 47	IO	R1	R3
gpio_48	General-purpose IO 48	IO	R2	T3
gpio_49	General-purpose IO 49	IO	T2	U2
gpio_50	General-purpose IO 50	IO	W1	V1
gpio_51	General-purpose IO 51	IO	Y1	V2
gpio_52	General-purpose IO 52	IO	H3	NA
gpio_53	General-purpose IO 53	IO	V8	NA
gpio_54	General-purpose IO 54	IO	U8	D2
gpio_55	General-purpose IO 55	IO	T8	F4
gpio_56	General-purpose IO 56	IO	R8	G5
gpio_57	General-purpose IO 57	IO	P8	F3
gpio_58	General-purpose IO 58	IO	N8	G4
gpio_59	General-purpose IO 59	IO	T4	W2
gpio_60	General-purpose IO 60	IO	G3	K5
gpio_61	General-purpose IO 61	IO	U3	L1
gpio_62	General-purpose IO 62	IO	H1	E1
gpio_63	General-purpose IO 63	IO	L8	NA
gpio_64	General-purpose IO 64	IO	K8	NA
gpio_65	General-purpose IO 65	IO	J8	C2
gpio_66	General-purpose IO 66	IO	D28	G22
gpio_67	General-purpose IO 67	IO	D26	E22
gpio_68	General-purpose IO 68	IO	D27	F22
gpio_69	General-purpose IO 69	IO	E27	J21
gpio_70	General-purpose IO 70	IO	AG22	AC19
gpio_71	General-purpose IO 71	IO	AH22	AB19
gpio_72	General-purpose IO 72	IO	AG23	AD20
gpio_73	General-purpose IO 73	IO	AH23	AC20
gpio_74	General-purpose IO 74	IO	AG24	AD21
gpio_75	General-purpose IO 75	IO	AH24	AC21
gpio_76	General-purpose IO 76	IO	E26	D24
gpio_77	General-purpose IO 77	IO	F28	E23
gpio_78	General-purpose IO 78	IO	F27	E24
gpio_79	General-purpose IO 79	IO	G26	F23
gpio_80	General-purpose IO 80	IO	AD28	AC22
gpio_81	General-purpose IO 81	IO	AD27	AC23
gpio_82	General-purpose IO 82	IO	AB28	AB22
gpio_83	General-purpose IO 83	IO	AB27	Y22
gpio_84	General-purpose IO 84	IO	AA28	W22
gpio_85	General-purpose IO 85	IO	AA27	V22
gpio_86	General-purpose IO 86	IO	G25	J22
gpio_87	General-purpose IO 87	IO	H27	G23
gpio_88	General-purpose IO 88	IO	H26	G24
gpio_89	General-purpose IO 89	IO	H25	H23
gpio_90	General-purpose IO 90	IO	E28	D23
gpio_91	General-purpose IO 91	IO	J26	K22

PRODUCT PREVIEW

Table 2-22. General-Purpose IOs Signals Description⁽²⁾ (continued)

SIGNAL NAME	DESCRIPTION	TYPE ⁽¹⁾	BALL BOTTOM (CBB Pkg.)	BALL BOTTOM (CUS Pkg.)
gpio_92	General-purpose IO 92	IO	AC27	V21
gpio_93	General-purpose IO 93	IO	AC28	W21
gpio_94	General-purpose IO 94	IO	A24	A22
gpio_95	General-purpose IO 95	IO	A23	E18
gpio_96	General-purpose IO 96	IO	C25	B22
gpio_97	General-purpose IO 97	IO	C27	J19
gpio_98	General-purpose IO 98	IO	C23	H24
gpio_99	General-purpose IO 99	I	AG17	AB18
gpio_100	General-purpose IO 100	I	AH17	AC18
gpio_101	General-purpose IO 101	IO	B24	G19
gpio_102	General-purpose IO 102	IO	C24	F19
gpio_103	General-purpose IO 103	IO	D24	G20
gpio_104	General-purpose IO 104	IO	A25	B21
gpio_105	General-purpose IO 105	IO	K28	L24
gpio_106	General-purpose IO 106	IO	L28	K24
gpio_107	General-purpose IO 107	IO	K27	J23
gpio_108	General-purpose IO 108	IO	L27	K23
gpio_109	General-purpose IO 109	IO	B25	F21
gpio_110	General-purpose IO 110	IO	C26	G21
gpio_111	General-purpose IO 111	IO	B26	C22
gpio_112	General-purpose IO 112	I	AG19	NA
gpio_113	General-purpose IO 113	I	AH19	NA
gpio_114	General-purpose IO 114	I	AG18	NA
gpio_115	General-purpose IO 115	I	AH18	NA
gpio_116	General-purpose IO 116	IO	P21	V20
gpio_117	General-purpose IO 117	IO	N21	T21
gpio_118	General-purpose IO 118	IO	R21	V19
gpio_119	General-purpose IO 119	IO	M21	R20
gpio_120	General-purpose IO 120	IO	N28 / T28	M23 / R21
gpio_121	General-purpose IO 121	IO	M27 / T25	L23 / R23
gpio_122	General-purpose IO 122	IO	N27 / R28	M22 / P23
gpio_123	General-purpose IO 123	IO	N26	M21
gpio_124	General-purpose IO 124	IO	N25 / T26	M20
gpio_125	General-purpose IO 125	IO	P28 / T27	N23
gpio_126	General-purpose IO 126	IO	D25 / P27	J20 / N22
gpio_127	General-purpose IO 127	IO	P26	N21
gpio_128	General-purpose IO 128	IO	R27	N20
gpio_129	General-purpose IO 129	IO	R25	P24
gpio_130	General-purpose IO 130	IO	AE2 / U28	Y1 / T23
gpio_131	General-purpose IO 131	IO	AG5 / U27	AB5 / U24
gpio_132	General-purpose IO 132	IO	AH5	AB3
gpio_133	General-purpose IO 133	IO	AH4	Y3
gpio_134	General-purpose IO 134	IO	AG4	W3
gpio_135	General-purpose IO 135	IO	AF4	V3
gpio_136	General-purpose IO 136	IO	AE4	AB2
gpio_137	General-purpose IO 137	IO	AH3	AA2

PRODUCT PREVIEW

Table 2-22. General-Purpose IOs Signals Description⁽²⁾ (continued)

SIGNAL NAME	DESCRIPTION	TYPE⁽¹⁾	BALL BOTTOM (CBB Pkg.)	BALL BOTTOM (CUS Pkg.)
gpio_138	General-purpose IO 138	IO	AF3	Y2
gpio_139	General-purpose IO 139	IO	AE3	AA1
gpio_140	General-purpose IO 140	IO	AF6	V6
gpio_141	General-purpose IO 141	IO	AE6	V5
gpio_142	General-purpose IO 142	IO	AF5	W4
gpio_143	General-purpose IO 143	IO	AE5	V4
gpio_144	General-purpose IO 144	IO	AB26	NA
gpio_145	General-purpose IO 145	IO	AB25	NA
gpio_146	General-purpose IO 146	IO	AA25	NA
gpio_147	General-purpose IO 147	IO	AD25	NA
gpio_148	General-purpose IO 148	IO	AA8	W7
gpio_149	General-purpose IO 149	IO	AA9	W6
gpio_150	General-purpose IO 150	IO	W8	AC2
gpio_151	General-purpose IO 151	IO	Y8	V7
gpio_152	General-purpose IO 152	IO	AE1	NA
gpio_153	General-purpose IO 153	IO	AD1	NA
gpio_154	General-purpose IO 154	IO	AD2	NA
gpio_155	General-purpose IO 155	IO	AC1	NA
gpio_156	General-purpose IO 156	IO	Y21	W19
gpio_157	General-purpose IO 157	IO	AA21	AB20
gpio_158	General-purpose IO 158	IO	V21	W18
gpio_159	General-purpose IO 159	IO	U21	Y18
gpio_160	General-purpose IO 160	IO	T21	AA18
gpio_161	General-purpose IO 161	IO	K26	AA19
gpio_162	General-purpose IO 162	IO	W21	V18
gpio_163	General-purpose IO 163	IO	H18	A23
gpio_164	General-purpose IO 164	IO	H19	B23
gpio_165	General-purpose IO 165	IO	H20	B24
gpio_166	General-purpose IO 166	IO	H21	C23
gpio_167	General-purpose IO 167	IO	B23	F18
gpio_168	General-purpose IO 168	IO	AF15	AC15
gpio_169	General-purpose IO 169	IO	U26	U23
gpio_170	General-purpose IO 170	IO	J25	A24
gpio_171	General-purpose IO 171	IO	AB3	T5
gpio_172	General-purpose IO 172	IO	AB4	R4
gpio_173	General-purpose IO 173	IO	AA4	T4
gpio_174	General-purpose IO 174	IO	AC2	T6
gpio_175	General-purpose IO 175	IO	AC3	NA
gpio_176	General-purpose IO 176	IO	AB1	NA
gpio_177	General-purpose IO 177	IO	AB2	R5
gpio_178	General-purpose IO 178	IO	AA3	N5
gpio_179	General-purpose IO 179	IO	Y2	N4
gpio_180	General-purpose IO 180	IO	Y3	N3
gpio_181	General-purpose IO 181	IO	Y4	M5
gpio_182	General-purpose IO 182	IO	V3	M4
gpio_183	General-purpose IO 183	IO	AE15	AC14

PRODUCT PREVIEW

Table 2-22. General-Purpose IOs Signals Description⁽²⁾ (continued)

SIGNAL NAME	DESCRIPTION	TYPE ⁽¹⁾	BALL BOTTOM (CBB Pkg.)	BALL BOTTOM (CUS Pkg.)
gpio_184	General-purpose IO 184	IO	AF14	AC13
gpio_185	General-purpose IO 185	IO	AG14	AC12
gpio_186	General-purpose IO 186	IO	AE22	AE6
gpio_188	General-purpose IO 188	IO	U25	W24
gpio_189	General-purpose IO 189	IO	V28	V23
gpio_190	General-purpose IO 190	IO	V27	W23
gpio_191	General-purpose IO 191	IO	V26	T22

(1) Type = Ball type for this specific function (I = Input, O = Output, Z = high-impedance, D = Open Drain, DS = Differential, A = Analog)

(2) NA in table stands for Not Applicable.

(3) The subsystem pin multiplexing options are not described in [Table 2-1](#) and [Table 2-3](#)

2.4.8 System and Miscellaneous Terminals

Table 2-23. System and Miscellaneous Signals Description

SIGNAL NAME	DESCRIPTION	TYPE ⁽¹⁾	BALL BOTTOM (CBB Pkg.)	BALL TOP (CBB Pkg.)	BALL BOTTOM (CUS Pkg.)
sys_32k	32-kHz clock input	I	AE25	NA	AA16
sys_xtalin	Main input clock. Oscillator input or LVCMOS at 19.2, 13, or 12 MHz.	I	AE17	NA	AD15
sys_xtalout	Output of oscillator	O	AF17	NA	AD14
sys_altdclk	Alternate clock source selectable for GPTIMERS (maximum 54 MHz), USB (48 MHz), or NTSC/PAL (54 MHz)	I	J25	NA	A24
sys_clkreq	Request from OMAP3515/03 device for system clock (open source type)	IO	AF25	NA	Y13
sys_clkout1	Configurable output clock1	O	AG25	NA	Y7
sys_clkout2	Configurable output clock2	O	AE22	NA	AA6
sys_boot0	Boot configuration mode bit 0	I	AH26	NA	AB12
sys_boot1	Boot configuration mode bit 1	I	AG26	NA	AC16
sys_boot2	Boot configuration mode bit 2	I	AE14	NA	AD17
sys_boot3	Boot configuration mode bit 3	I	AF18	NA	AD18
sys_boot4	Boot configuration mode bit 4	I	AF19	NA	AC17
sys_boot5	Boot configuration mode bit 5	I	AE21	NA	AB16
sys_boot6	Boot configuration mode bit 6	I	AF21	NA	AA15
sys_nreswron	Power On Reset	I	AH25	NA	AA10
sys_nreswarm	Warm Boot Reset (open drain output)	IOD	AF24	NA	Y10
sys_nirq	External FIQ input	I	AF26	NA	W16
sys_nvmode1	Indicates the voltage mode	O	AD26	NA	Y16
sys_nvmode2	Indicates the voltage mode	O	AE26	NA	Y15
sys_off_mode	Indicates the voltage mode	O	AF22	NA	AD23
sys_ndmareq0	External DMA request 0 (system expansion). Level (active low) or edge (falling) selectable.	I	U8	NA	D2
sys_ndmareq1	External DMA request 1 (system expansion). Level (active low) or edge (falling) selectable.	I	T8 / J8	NA	F4 / C2
sys_ndmareq2	External DMA request 2 (system expansion). Level (active low) or edge (falling) selectable.	I	L3 / R8	NA	H2 / G5
sys_ndmareq3	External DMA request 3 (system expansion). Level (active low) or edge (falling) selectable.	I	K3 / P8	NA	G2 / F3
sys_secure_indicator	MSECURE transactions indicator	O	AG9	NA	AD5
sys_drm_msecure	MSECURE output	O	AF9	NA	AC4
adpllv2d_dithering_en1	adpll dithering enable	I	AA21	NA	AB20
adpllv2d_dithering_en2	adpll dithering enable	I	AC3	NA	NA
sys_ipmcsws	Reserved	AI	B1	NA	A1
sys_opmcsws	Reserved	AO	A1	NA	A2
pop_int0_ft	POP dedicated control signal	O	AG11	AB9	TBD
pop_int1_ft	POP dedicated control signal	O	AH11	AC9	TBD
pop_tq_temp_sense_ft	POP dedicated control signal	NA	AH16	AC14	TBD
pop_reset_rp_ft	POP dedicated control signal	NA	AG13	AB11	TBD

(1) Type = Ball type for this specific function (I = Input, O = Output, Z = high-impedance, D = Open Drain, DS = Differential, A = Analog)

2.4.9 Power Supplies

Table 2-24. Power Supplies Signals Description⁽¹⁾

SIGNAL NAME	DESCRIPTION	BALL BOTTOM (CBB Pkg.)	BALL TOP (CBB Pkg.)	BALL BOTTOM (CUS Pkg.)
vdd_mpu	ARM power domain	Y9 / W9 / T9 / R9 / M9 / L9 / J9 / Y10 / U10 / T10 / R10 / N10 / M10 / L10 / J10 / Y11 / W11 / K11 / J11 / W12 / K13 / Y14 / K14 / J14 / Y15 / W15 / J15	NA	W13/ W12/ V13/ V12/ U13/ U12/ T8/ T7/ R8/ R7/ R6/ N8/ N7/ N6/ M12/ M8/ M7/ M6/ L12/ L11/ J10/ J9/ H10/ H9/ G10/ G9/F10
vdd_core	Core power domain	AC4 / J4 / H4 / D8 / AE9 / D9 / D15 / Y16 / AE18 / Y18 / W18 / K18 / J18 / AE19 / Y19 / U19 / T19 / N19 / M19 / J19 / Y20 / W20 / V20 / U20 / P20 / N20 / K20 / J20 / D22 / D23 / AE24 / M25 / L25 / E25	NA	T20/ T19/ T18/ T17/ R19/ R18/ R17/ M15/ M14/ L15/ L14/ K19/ K18/ K17/ J18/ J17/ H13/ H12/ G13/ G12/ F13/ F12
cap_vdd_wkup	Wakeup/EMU/memory domains, connect capacitor	AA15	NA	Y12
bg_testout	Used for band gap test	U4	NA	AD1
vdds_dppll_dll	DLL IO power domain (1.8 V): internal connection to PLL_VDDS, power supply for 3PLL (1.8 V)	K15	NA	G18
vpp	eFuse programming	G1	NA	B1
vdda_dac	Video DAC power plane	V25	NA	AB13
vssa_dac	Video DAC ground plane	Y26	NA	AB15
vdds	IO power plane	AD3 / AD4 / W4 / AF8 / AE8 / AF16 / AE16 / AF23 / AE23 / F25 / F26 / AG27/ AE27/ AG20/ H28/ AG21/P25	NA	Y9 / W10 / W9 / V10 / V9 / U10 / N19 / N18 / N17 / M19 / M18 / M17 / H8
vdds_mem	Memory IO power plane	U1 / J1 / F1 / J2 / F2 / R4 / B5 / A5 / AH6 / B8 / A8 / B12 / A12 / D16 / C16 / B18 / A18 / B22 / A22 / G28 / C28	AC5 / P1 / H1 / F23 / E1 / C23 / A4 / A7 / A10 / A15 / A18	K8 / K7 / K6 / J8 / J7 / J6 / H15 / G16 / G15 / F16 / F15 / E16
vdds_dppll_per	Peripheral DPLLs power rail	AA16	NA	U17
vdds_wkup_bg	For wakeup LDO and VDDA (2 LDOs SRAM and BG)	AA14	NA	AA13
vss	Ground	AG2 / U2 / B2 / AG3 / W3 / P3 / J3 / E3 / A3 / P4 / E4 / AG6 / D7 / C7 / V9 / U9 / P9 / N9 / K9 / W10 / V10 / P10 / K10 / D10 / C10 / AF12 / AE12 / Y12 / K12 / J12 / Y13 / W13 / J13 / D13 / C13 / W14 / K16 / J16 / Y17 / W17 / K17 / J17 / W19 / V19 / R19 / P19 / L19 / K19 / D19 / C19 / AF20 / AE20 / T20 / R20 / M20 / L20 / D21 / C22 / AC25 / Y25 / W25 / AC26 / R26 / L26 / A26 / G27 / B27/ AA26/ M28/ AG16/ AH21	H2 / B18 / AC20 / AB5 / AB14 / AB20 / P2 / F22 / E2 / C22 / B4 / B7 / B10 / B15	W15/ V16/ V15/ U16/ U15/ U14/ U11/ U9/T16/ T15/ T14/ T13/ T12/ T11/ T10/ T9/ R15/ R14/ R11/ R10/ P17/ P15/ P14/ P13/P12/ P11/ P10/ P8/ N16/ N15/ N14/ N13/ N12/ N11/ N10/ N9/ M16/ M13/ M11/ M10/ M9/ L17/ L13/ L10/ L8/ K15/ K14/ K11/ K10/ J16/ J15/ J14/ J13/ J12/ J11/H16/ H14/ H11
vdds_sram	SRAM LDOs	W16	NA	AA12

PRODUCT PREVIEW

Table 2-24. Power Supplies Signals Description⁽¹⁾ (continued)

SIGNAL NAME	DESCRIPTION	BALL BOTTOM (CBB Pkg.)	BALL TOP (CBB Pkg.)	BALL BOTTOM (CUS Pkg.)
vdds_mmc1	MMC IO power domain for CMD, CLK, and DAT(0..7)	K25	NA	N24
cap_vdd_sram_mpu	SRAM LDO capacitance for VDDRAM1	V4	NA	U8
cap_vdd_sram_core	SRAM LDO capacitance for VDDRAM2	L21	NA	H17
pop_dds_vdd_ft	POPped SDRAM power	A15 / J28 / M1 / AF28 / AE28	AA23 / Y23 / K1 / H23 / A12	TBD
pop_flash_vpp_ft	POPped flash vpp	AH13	AC11	TBD
pop_flash_vdd_ft	POPped flash power	N1 / AA1 / AF1 / AH10 / AH15	AC8 / AC13 / AA1 / U1 / L1	TBD
pop_vss_ft	POPped devices ground	B15 / J27 / M2 / M26 / N2 / AA2 / AF2 / AF27 / AG10 / AG15	AB8 / AB13 / AA2 / AA22 / U2 / L2 / K2 / K22 / H22 / B12	TBD

(1) NA = Not Applicable.

3 ELECTRICAL CHARACTERISTICS

3.1 Power Domains

The OMAP3515/03 device integrates enhanced features that dynamically adapt energy consumption according to application needs and performance requirements.

The OMAP3515/03 device includes an enhanced power-management scheme based on:

- Nine independent functional voltage domains on chip partitioning
- Multiple voltage domains
- Voltage scaling support
- Enhanced memory retention support
- Optimized device off mode
- Centralized management of power, reset, and clock

The external power supplies of OMAP3515/03 are:

- vdd_mpu for the ARM
- vdd_core for macros
- vdds for IO macros
- vdds_mem for memory macros
- vdds_sram for SRAM LDOs
- vdds_dpll_dll for DLL IO
- vdds_dpll_per for peripheral DPLLs
- vdds_wkup_bg for wakeup LDO and VDDA (2 LDOs: SRAM and BandGap)
- vdda_dac for video DAC
- vdds_mmc1 for MMC IO
- vpp for eFuse

The supply voltages are detailed in [Table 3-3](#).

[Figure 3-1](#) illustrates the power domains:

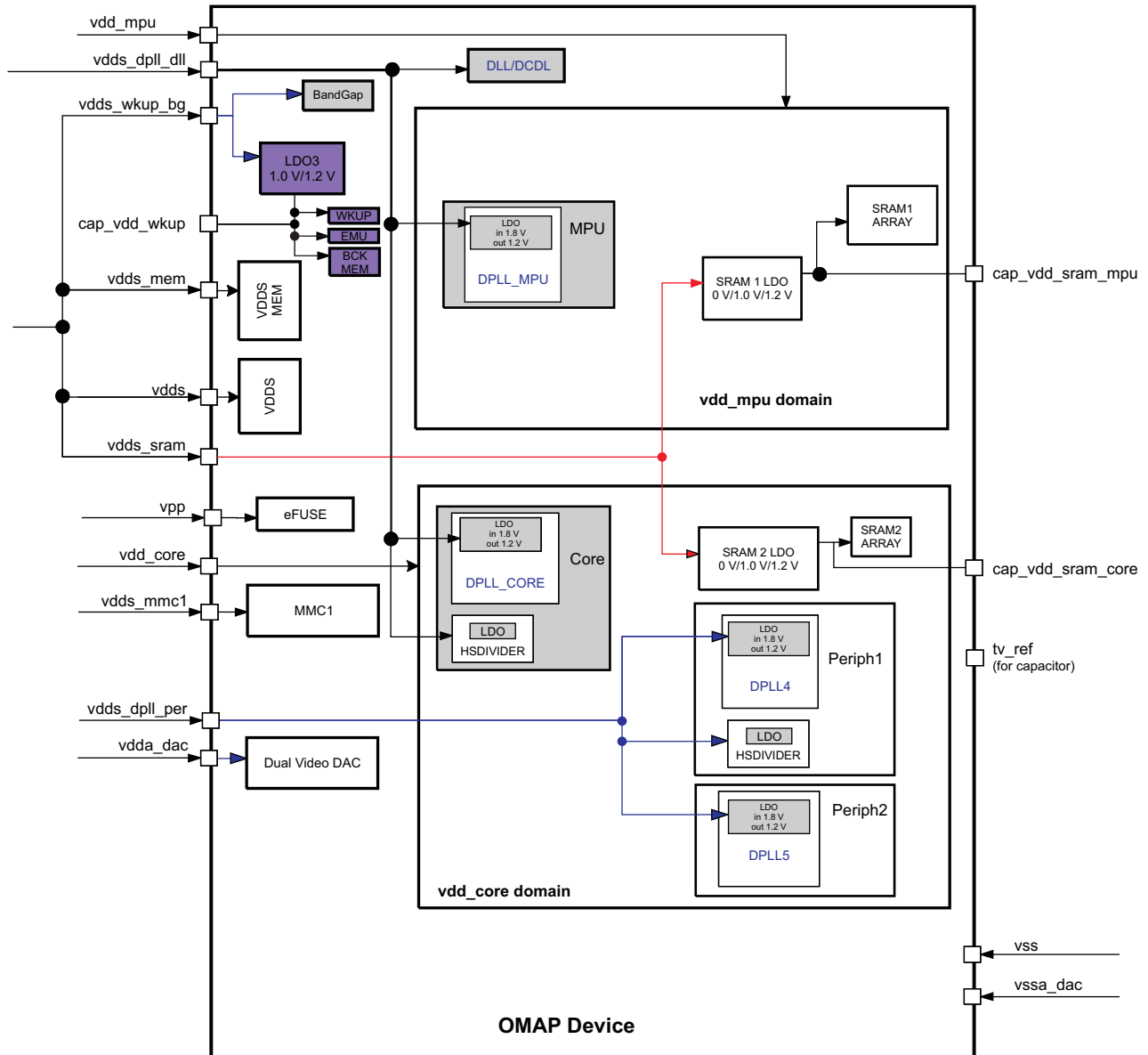

030-003

Figure 3-1. OMAP3515/03 Power Domains

This power domain segmentation switches off (or places in retention state) domains that are unused while keeping others active. This implementation is based on internal switches that independently control each power domain.

A power domain regular logic is attached to one of the device V_{DD} supplies through a primary domain switch. When the primary switch is open, most of the logic supply is off, resulting in a low-leakage state of the domain. Embedded switches are implemented for all power domains except the wake-up domain. This allows the domain to be powered off, if not being used, to give maximum power savings. For more information, see the PRCM chapter of the *OMAP35xx ES2.0 Technical Reference Manual (TRM)* [literature number [SPRUF5](#)].

All domain output signals at the interface between power domains are connected through isolation latch cells. These cells ensure a proper electrical isolation between the domains and an appropriate interface state at the domain boundaries.

PRODUCT PREVIEW

3.2 Absolute Maximum Ratings

The following list of absolute maximum ratings is specified over operating junction temperature range. Stresses beyond those listed under absolute maximum ratings may cause permanent damage to the device. These are stress ratings only and functional operation of the device at these or any other conditions beyond those indicated under recommended operating conditions is not implied. Exposure to absolute-maximum-rated conditions for extended periods may affect device reliability.

The OMAP3515/03 device adheres to EIA/JESD22–A114, Electrostatic Discharge (ESD) Sensitivity Testing Human Body Model (HBM). Minimum pass level for HBM is ± 2 kV.

Table 3-1. Absolute Maximum Ratings Over Operating Junction Temperature Range

PARAMETER		MIN	MAX	UNIT
vdd_mpu vdd_core	Supply voltage range for core macros	–0.5	1.6	V
vdds vdds_mem	Second supply voltage range for 1.8-V I/O macros	–0.5	2.25	V
V _{PAD}	Voltage range at PAD	–0.5	V _{dds} + 0.5	V
vdda	Supply voltage range for analog macros	–0.5	2.43	V
V _{ESD}	ESD stress voltage ⁽¹⁾	HBM (human body model) ⁽⁴⁾	2000	V
		CDM (charged device model) ⁽⁵⁾	500	
I _{IOI}	Current-pulse injection on each I/O pin ⁽³⁾		200	mA
I _{clamp}	Clamp current for an input or output	–20	20	mA
T _{stg}	Storage temperature range ⁽²⁾	–65	150	°C

(1) Electrostatic discharge (ESD) to measure device sensitivity/immunity to damage caused by electrostatic discharges into the device.

(2) These temperatures extreme do not simulate actual operating conditions but exaggerate any faults that might exist.

(3) Each device is tested with I/O pin injection of 200 mA with a stress voltage of 1.5 times maximum vdd at room temperature.

(4) JEDEC JESD22–A114 D with the following exception-no connect pins are not stressed. 2000V Human Body Model (HBM)

(5) JEDEC JESD22–C101C with the following exception-split out pin groupings to eliminate cumulative stress effect

This section includes the maximum power consumption for each power domain (core, etc.). [Table 3-2](#) summarizes the power consumption at the ball level.

Table 3-2. Estimated Maximum Power Consumption At Ball Level

PARAMETER		MAX	UNIT	
Signal	Description			
vdd_mpu	Processors	OMAP3515 (SmartReflex™ Enabled)	680	mA
		OMAP3515 (SmartReflex™ Disabled)	850	
		OMAP3503 (SmartReflex™ Enabled)	680	
		OMAP3503 (SmartReflex™ Disabled)	850	
vdd_core	Core	OMAP3515 (SmartReflex™ Enabled)	430	mA
		OMAP3515 (SmartReflex™ Disabled)	500	
		OMAP3503 (SmartReflex™ Enabled)	320	
		OMAP3503 (SmartReflex™ Disabled)	370	
vdda_dac	Video DAC	65	mA	
vdss_dppll_dll	DLL + DPLL MPU, and core	25	mA	
vdss_dppll_per	DPLL peripheral 1 and peripheral 2	15	mA	
vdss_sram	Processors and core LDO (LDO1 and LDO2)	41	mA	
vdss_wkup_bg	Bandgap, wakeup + LDO, EMU off	6	mA	
vdss_mem	Standard I/Os (SRDC+GPMC)	37	mA	
vdds	Standard I/Os (all excluding SRDC and GPMC)	63	mA	
vdds_mmc1	MMC I/O ⁽¹⁾	20	mA	
vpp	eFuse	50	mA	

(1) MMC card and I/O card are not included.

3.3 Recommended Operating Conditions

All OMAP3515/03 modules are used under the operating conditions contained in [Table 3-3](#).

Table 3-3. Recommended Operating Conditions⁽³⁾

PARAMETER	DESCRIPTION	MIN	NOM	MAX	UNIT	
V _{DD1} (vdd_mpu) ⁽¹⁾	OMAP processor core supply	OPP5: Overdrive	$V_{DD1NOM} - (0.04 \cdot V_{DD1NOM})$	1.19 - 1.35	$V_{DD1NOM} + (0.04 \cdot V_{DD1NOM})$	V
		OPP4: Mid-Overdrive	$V_{DD1NOM} - (0.04 \cdot V_{DD1NOM})$	1.07 - 1.27	$V_{DD1NOM} + (0.04 \cdot V_{DD1NOM})$	V
		OPP3: Nominal	$V_{DD1NOM} - (0.04 \cdot V_{DD1NOM})$	1.00 - 1.20	$V_{DD1NOM} + (0.04 \cdot V_{DD1NOM})$	V
		OPP2: Low-Power	$V_{DD1NOM} - (0.04 \cdot V_{DD1NOM})$	0.90 - 1.00	$V_{DD1NOM} + (0.04 \cdot V_{DD1NOM})$	V
		OPP1: Ultra Low-Power	$V_{DD1NOM} - (0.04 \cdot V_{DD1NOM})$	0.80 - 0.90	$V_{DD1NOM} + (0.04 \cdot V_{DD1NOM})$	V
V _{DD2} (vdd_core) ⁽¹⁾	OMAP processor core logic supply	OPP3: Nominal	$V_{DD2NOM} - (0.04 \cdot V_{DD2NOM})$	0.95-1.15	$V_{DD2NOM} + (0.04 \cdot V_{DD2NOM})$	V
		OPP2: Low-Power	$V_{DD2NOM} - (0.04 \cdot V_{DD2NOM})$	0.85-1.00	$V_{DD2NOM} + (0.04 \cdot V_{DD2NOM})$	V
		OPP1: Ultra Low-Power	$V_{DD2NOM} - (0.04 \cdot V_{DD2NOM})$	0.80-0.90	$V_{DD2NOM} + (0.04 \cdot V_{DD2NOM})$	V
vdds	Supply voltage for I/O macros	1.71	1.8	1.89	V	
vdds_mem	Supply voltage for memory I/O macros	1.71	1.8	1.89	V	
vdds_mmc1	Supply voltage for MMC1 macro in 1.8-V mode	1.71	1.8	1.89	V	
	Supply voltage for MMC1 macro in 3-V mode	2.7	3	3.3	V	
vdds_wkup_bg	Wakeup LDO	1.71	1.8	1.89	V	
vdda_dac	Analog supply voltage for video DAC	1.71	1.8	1.89	V	
vdds_sram	SRAM LDOs	1.71	1.8	1.89	V	
vdds_dppll_per	Peripherals DPLLs power supply	1.71	1.8	1.89	V	
vdds_dppll_dll	Supply voltage for DPLLs I/Os	1.71	1.8	1.89	V	
vpp ⁽²⁾	eFuse programming				V	
vss	Ground	0	0	0	V	
vssa_dac	Dedicated ground for DAC	0	0	0	V	
T _J	Operating junction temperature range	0	–	90	°C	

(1) Voltage can be adapted using SmartReflex™. When not using SmartReflex™, the highest nominal voltage must be used for the OPP selected. For example, vdd_mpu must be set to 1.20V+/-4% when using OPP3. OPP = operating point.

(2) It is recommended not to connect this pin. It is just used for eFuse programming on package unit.

(3) Using the device at OPP5 (Overdrive) or using multiple OPPs may impact product lifetime. For assistance in understanding the relationship between actual application conditions, temperature, and Power on Hours (POH) see the *OMAP 35xx Use Conditions and Product Life* applications note (literature number SPRATBD).

3.4 DC Electrical Characteristics

Table 3-4 summarizes the dc electrical characteristics.

Table 3-4. DC Electrical Characteristics

PARAMETER		MIN	NOM	MAX	UNIT
LVCMOS Pin Buffers - CBB: N28, M27, N27, N26, N25, P28 / CUS: M23, L23, M22, M21, M20, N23					
V _{IH}	High-level input voltage	vdds = 1.8 V	0.65 × vdds	vdds + 0.3	V
		vdds = 3.0 V	0.625 × vdds	vdds + 0.3	
V _{IL}	Low-level input voltage	vdds = 1.8 V	−0.3	0.35 × vdds	V
		vdds = 3.0 V	−0.3	0.25 × vdds	
V _{OH}	High-level output voltage ⁽³⁾	vdds = 1.8 V	vdds − 0.2		V
		vdds = 3.0 V	0.75 × vdds		
V _{OH}					
V _{OL}	Low-level output voltage ⁽³⁾	vdds = 1.8 V		0.2	V
		vdds = 3.0 V		0.125 × vdds	
V _{OL}					
t _T	Input transition time (rise time, t _R or fall time, t _F evaluated between 10% and 90% at PAD)	Normal Mode		10	ns
		High-Speed Mode		3	
LVDS/CMOS Pin Buffers - CBB: AG19, AH19, AG18, AH18, AG17, AH17/ CUS: AB18, AC18					
Low-Power Receiver (LP-RX)					
V _{IL}	Low-level input threshold			500	mV
V _{IH}	High-level input threshold	800			mV
V _{HYS}	Input hysteresis	25			mV
Ultralow-Power Receiver (ULP-RX)					
V _{IL-ULPM}	Low-level input threshold, ULPM			300	mV
V _{IH}	High-level input threshold	880			mV
High-Speed Receiver (HS-RX)					
V _{IDTH}	Differential input high threshold	70			mV
V _{IDTL}	Differential input low threshold			−70	mV
V _{IDMAX}	Maximum differential input voltage			270	mV
V _{ILHS}	Single-ended input low voltage	−40			mV
V _{IHHS}	Single-ended input high voltage			460	mV
V _{CMRXDC}	Common-mode voltage	70		330	mV
LVDS/CMOS Pin Buffers - CBB: K28, L28, K27, L27/ CUS: L24, K24, J23, K23					
V _{CM}	Input common mode voltage range	600	900	1200	mV
V _{OS}	Receiver Input dc offset	−20		20	mV
V _{ID}	Receiver input differential amplitude	140	200	400	mVpp
t _T	Input transition time (rise time, t _R or fall time, t _F evaluated between 10% and 90% at PAD)	267		533	ps
LVDS/CMOS Pin Buffers - CBB: AG22, AH22, AG23, AH23, AG24, AH24/ CUS: AC19, AB19, AD20, AC20, AD21, AC21					
High-Speed Transceiver (HS-TX)					
V _{OHHS}	HS output high voltage			360	mV
V _{OD}	HS transmit differential voltage	140	200	270	mV
V _{CMTX}	HS transmit static common mode voltage	150	200	250	mV
Low-Power Transceiver (LP-TX)					
V _{OL}	Thevenin output low level	−50		50	mV
V _{OH}	Thevenin output high level	1.1	1.2	1.3	V
Low-Power Receiver (LP-RX)					

Table 3-4. DC Electrical Characteristics (continued)

PARAMETER		MIN	NOM	MAX	UNIT
V _{IL}	Low-level input threshold			550	mV
V _{IH}	High-level input threshold	880			mV
V _{HYST}	Input hysteresis	25			mV
Ultralow-Power Receiver (ULP-RX)					
V _{IL-ULPS}	Low-level input threshold, ULPM			300	mV
V _{IH}	High-level input threshold	880			mV
subLVDS/CMOS Pin Buffers - CBB: AA27, AA28, AB27, AB28, AD27, AD28, AC28, AC27/ CUS: V22, W22, Y22, AB22, AC23, AC22, W21, V21					
V _{od}	Differential voltage range @ R _L = 100 Ω	100	150	200	mV
V _{ocm}	Common mode voltage range	0.8	0.9	1	V
t _T	Input transition time (V _{od} rise time, t _R or V _{od} fall time, t _F evaluated between 20% and 80% at PAD)	200		500	ps
Standard LVCMOS Pin Buffers					
V _{IH}	High-level input voltage (Standard LVCMOS)	0.65 × v _{dds}			V
V _{IL}	Low-level input voltage (Standard LVCMOS)	0		0.35 × v _{dds}	V
V _{HYS}	Hysteresis voltage at an input ⁽¹⁾		0.1		V
V _{OH}	High-level output voltage, driver enabled, pullup or pulldown disabled	I _O = I _{OH} or I _O = -2 mA	v _{dds} - 0.45		V
		I _O = I _{OH} < -2 mA	v _{dds} - 0.40		
V _{OL}	Low-level output voltage with , driver enabled, pullup or pulldown disabled	I _O = I _{OL} or I _O = 2 mA		0.45	V
		I _O = I _{OL} < 2 mA		0.40	
t _T	Input transition time (rise time, t _R or fall time, t _F evaluated between 10% and 90% at PAD)	0		10 ⁽²⁾	ns
I _I	Input current with V _I = V _I max	-1		1	μA
I _{OZ}	Off-state output current for output in high impedance with driver only, driver disabled	-20		20	μA
	Off-state output current for output in high impedance with driver/receiver/pullup only, driver disabled, pullup not inhibited		-100		
	Off-state output current for output in high impedance with driver/receiver/pulldown only, driver disabled, pulldown not inhibited		100		
I _Z	Total leakage current through the PAD connection of a driver/receiver combination that may include a pullup or pulldown. The driver output is disabled and the pullup or pulldown is inhibited.	-20		20	μA

(1) V_{hys} is the magnitude of the difference between the positive-going threshold voltage V_{T+} and the negative-going voltage V_{T-}.

(2) This global value may be overridden on a per interface basis if another value is explicitly defined for that interface (for example, I²C).

(3) With 100 μA sink / source current at v_{dds_min}.

PRODUCT PREVIEW

3.5 Core Voltage Decoupling

For module performance, decoupling capacitors are required to suppress the switching noise generated by high frequency and to stabilize the supply voltage. A decoupling capacitor is most effective when it is close to the device because this minimizes the inductance of the circuit board wiring and interconnects.

Table 3-5 summarizes the power supplies decoupling characteristics.

Table 3-5. Core Voltage Decoupling Characteristics

PARAMETER	MIN	TYP	MAX	UNIT
Cvdd_mpu ⁽¹⁾	50	100	120	nF
Cvdd_core ⁽¹⁾	50	100	120	nF
Cvdds_sram		100		nF
Ccap_vdd_sram_mpu	0.7	1	1.3	μF
Ccap_vdd_sram_core	0.7	1	1.3	μF
Cvdd_wkup	0.7	1	1.3	μF
Cvdds_wkup_bg		100		nF
Cvdds_dpII_dll		100		nF
Cvdds_dpII_per		100		nF
Cvdda_dac		100		nF
Cvdds_mmc1		100		nF

(1) 1 capacitor per 2 to 4 balls

Figure 3-2 illustrates an example of power supply decoupling.

PRODUCT PREVIEW

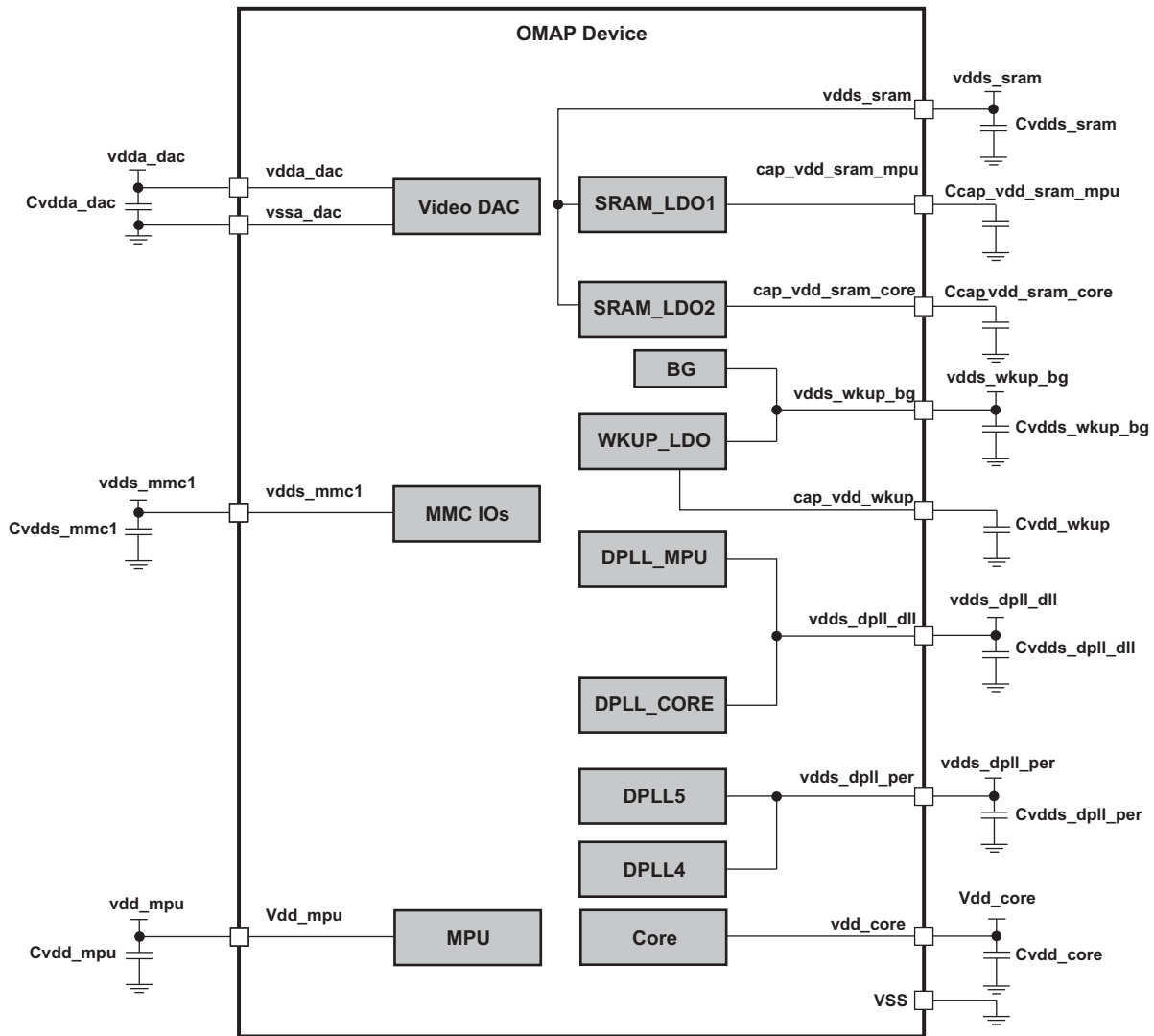

030-004

- (1) Decoupling capacitors must be placed as close as possible to the power ball. Choose the ground located closest to the power pin for each decoupling capacitor. Place the decoupling capacitor C_i in a group of 1, 2, or 3 balls; the total must be equal to the decoupling requirement. In case you interconnect powers, first insert the decoupling capacitor and then interconnect the powers.
- (2) The decoupling capacitor value depends on the board characteristics.

Figure 3-2. Power Supply Decoupling

3.6 Power-up and Power-down

This section provides the timing requirements for the OMAP3515/03 hardware signals.

3.6.1 Power-up Sequence

The following steps give an example of power-up sequence supported by the OMAP3515/03 device.

1. VDDS and VDDS_MEM are ramped ensuring a level on the IO domain and sys_nrespwron must be low. At the same time, VDDS_SRAM and VDDS_WKUP_BG can also be ramped.
2. Once VDDS_WKUP_BG rail is stabilized, VDD_CORE can be ramped.
3. Once VDD_CORE is stabilized, then VDD_MPU can be ramped.
4. VDDS_DPLL_DLL and VDDS_DPLL_PER rails can be ramped at any time during the above sequence.
5. sys_nrespwron can be released as soon as the VDDS_PLL_DLL rail is stabilized, and sys_xtalin and sys_32k clocks are stabilized.
6. During the whole sequence above, sys_nreswarm is held low by OMAP3515/03. sys_nreswarm is released after the eFuse check has been performed; that is, after sys_nrespwron is released.
7. The other power supplies can then be turned on upon software request.

Figure 3-3 shows the power-up sequence.

Note: If an external square clock is provided, it could be started after sys_nrespwron release provided it is clean: no glitch, stable frequency, and duty cycle.

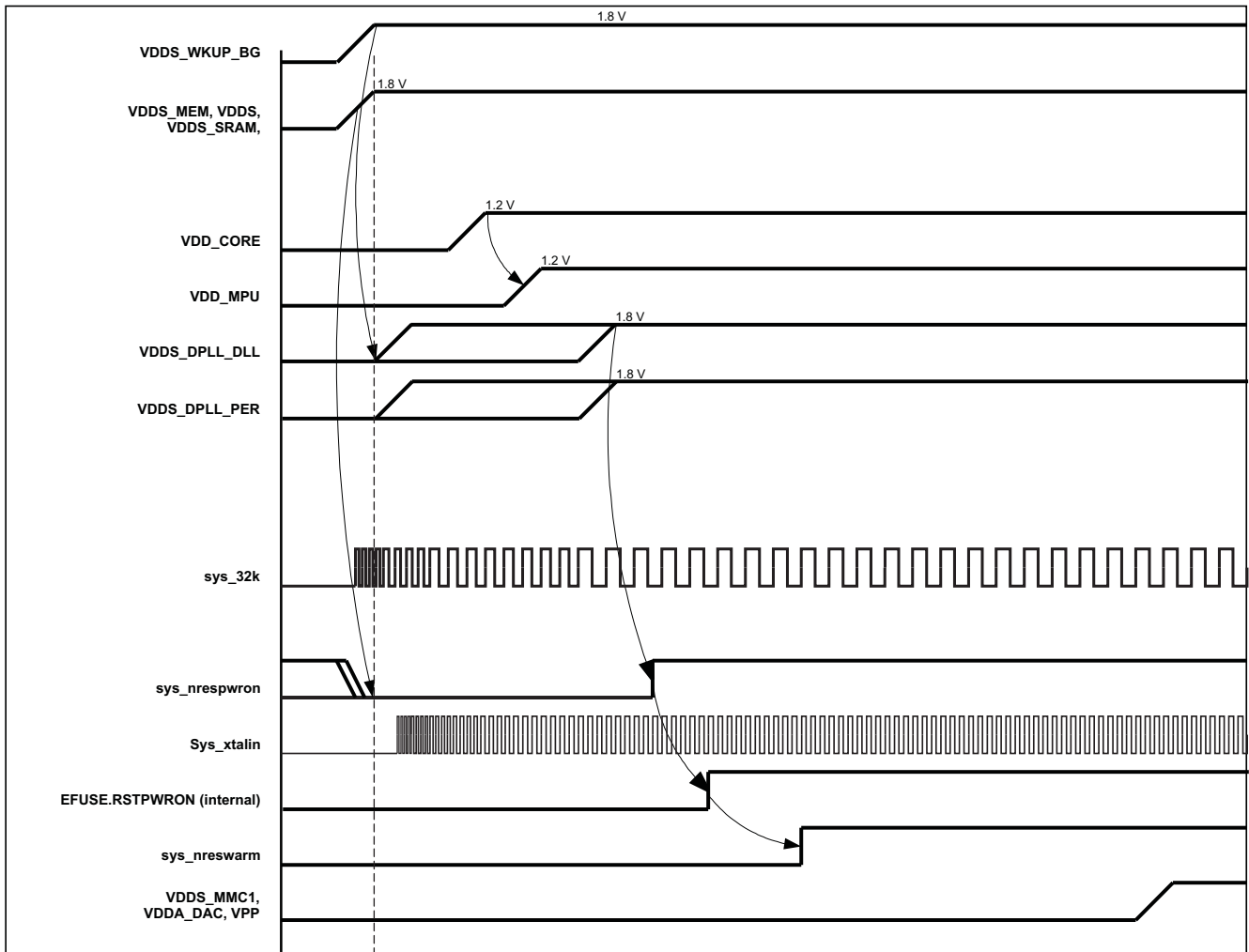

030-005

Figure 3-3. Power-up Sequence

3.6.2 Power-down Sequence

The OMAP3515/03 device proceeds with the power-down sequence shown in [Figure 3-4](#).

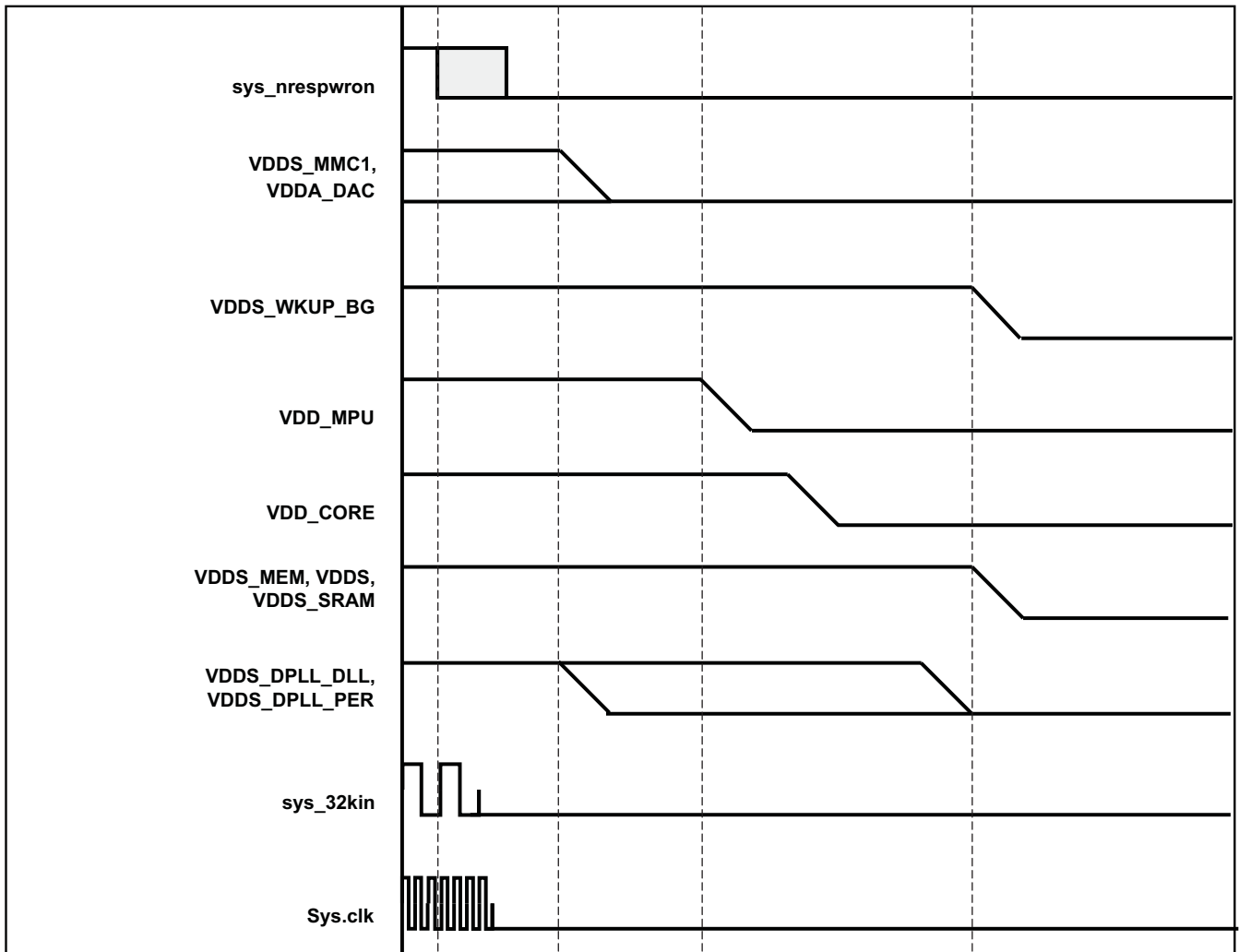

PRODUCT PREVIEW

030-006

Figure 3-4. Power-down Sequence

4 CLOCK SPECIFICATIONS

The OMAP3515/03 device has three external input clocks, a low frequency (sys_32k), a high frequency (sys_xtalin), and an optional (sys_altclk). The OMAP3515/03 device has two configurable output clocks, sys_clkout1 and sys_clkout2.

Figure 4-1 shows the interface to the external clock sources and clock outputs.

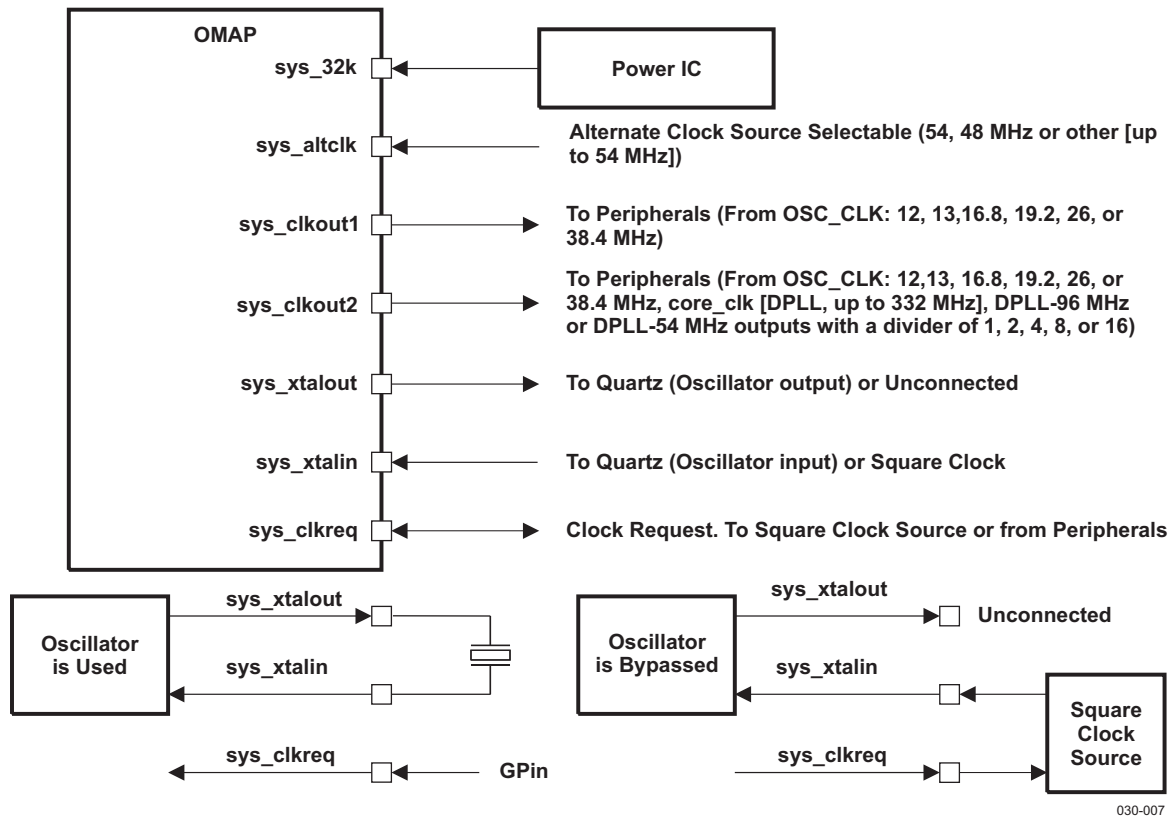

Figure 4-1. Clock Interface

The OMAP3515/03 device operation requires the following three input clocks:

- The 32-kHz frequency is used for low frequency operation. It supplies the wake-up domain for operation in lowest power mode (off mode). This clock is provided through the sys_32k pin.
- The system alternative clock can be used (through the sys_altclk pin) to provide alternative 48 or 54 MHz or other clock source (up to 54 MHz).
- The system clock input (12, 13, 16.8, 19.2, 26, or 38.4 MHz) is used to generate the main source clock of the OMAP3515/03 device. It supplies the DPLLs as well as several OMAP modules. The system clock input can be connected to either:
 - A crystal oscillator clock managed by sys_xtalin and sys_xtalout. In this case, the sys_clkreq is used as an input (GPIN).
 - A CMOS digital clock through the sys_xtalin pin. In this case, the sys_clkreq is used as an output to request the external system clock.

The OMAP3515/03 outputs externally two clocks:

- sys_clkout1 can output the oscillator clock (12, 13, 16.8, 19.2, 26, or 38.4 MHz) at any time. It can be controlled by software or externally using sys_clkreq control. When the device is in the off state, the sys_clkreq can be asserted to enable the oscillator and activate the sys_clkout1 without waking up the device. The off state polarity of sys_clkout1 is programmable.

- sys_clkout2 can output the oscillator clock (12, 13, 16.8, 19.2, 26, or 38.4 MHz), core_clk (core DPLL output), 96 MHz or 54 MHz. It can be divided by 2, 4, 8, or 16 and its off state polarity is programmable. This output is active only when the core power domain is active.

For more information on the OMAP3515/03 Applications Processor clocking structure, see the Power, Reset, and Clock management (PRCM) chapter of the *OMAP35xx Applications Processor TRM* (literature number [SPRUFA5](#)).

4.1 Input Clock Specifications

The clock system accepts three input clock sources:

- 32-kHz digital CMOS clock
- Crystal oscillator clock or CMOS digital clock (12, 13, 16.8, 19.2, 26, or 38.4 MHz)
- Alternate clock (48 or 54 MHz, or other up to 54 MHz)

4.1.1 Clock Source Requirements

Table 4-1 illustrates the requirements to supply a clock to the OMAP3515/03 device.

Table 4-1. Clock Source Requirements

PAD	CLOCK FREQUENCY		STABILITY	DUTY CYCLE	JITTER	TRANSITION
sys_32k	32.768 kHz		± 200 ppm	40% to 60%		< 20 ns
sys_xtalout	12, 13, 16.8, 19.2, 26, or 38.4 MHz	Crystal	± 50 ppm	45% to 55%	< 1%	< 3.6 ns
sys_xtalin		Square	± 25 ppm			
sys_altclk	48 or 54 MHz		± 50 ppm	40% to 60%	< 1%	< 5 ns

4.1.2 External Crystal Description

To supply a 12-, 13-, 16.8-, or 19.2-MHz clock to the OMAP3515/03, an external crystal can be connected to the sys_xtalin and sys_xtalout pins. Figure 4-2 describes the crystal implementation.

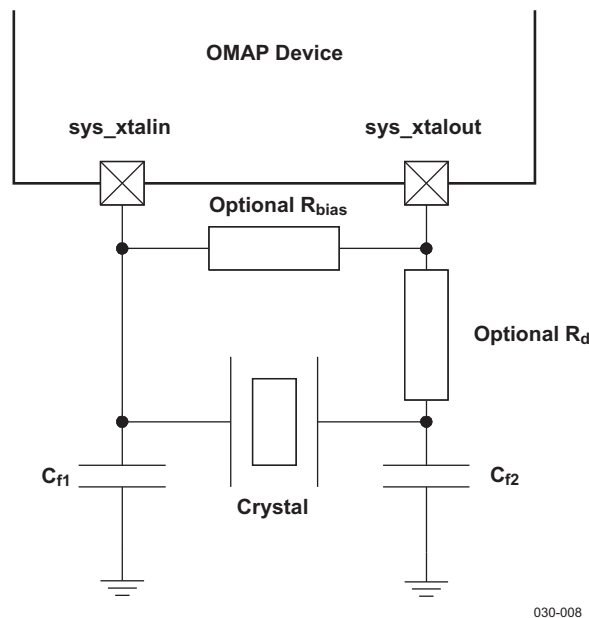

Figure 4-2. Crystal Implementation⁽¹⁾⁽²⁾⁽³⁾⁽⁴⁾

- (1) On the PCB, the oscillator components (crystal, foot capacitors, optional R_{bias} and R_d) must be located close to the package. All these components must be routed first with the lowest possible number of board vias.
- (2) An optional resistor R_d can be added in series with the crystal to debug or filter the harmonics; a footprint must be reserved on the PCB for use with 10-MHz crystals and feature low-drive levels.

- (3) A 120-kΩ internal bias resistor R_{bias} is used. The feedback resistor R_{bias} provides negative feedback to the oscillator to put it in the linear operating region; thus oscillation begins when power is applied.
- (4) C_{f1} and C_{f2} represent the total capacitance of the PCB and components excluding the power IC and crystal. Their values in fact depend on the crystal datasheet. In the datasheet of the crystal, the frequency is specified at a specific load capacitor value which is the equivalent capacitor of the two capacitors C_{f1} and C_{f2} connected to `sys_xtalin` and `sys_xtalout`. The frequency of the oscillations depends on the value of the capacitors (10 pF corresponds to a load capacitor of 5 pF for the crystal).

The crystal must be in the fundamental mode of operation and parallel resonant. [Table 4-2](#) summarizes the required electrical constraints.

Table 4-2. Crystal Electrical Characteristics

NAME	DESCRIPTION	MIN	TYP	MAX	UNIT
f_p	Parallel resonance crystal frequency ⁽¹⁾	12, 13, 16.8, or 19.2			MHz
C_L	Load capacitance for crystal parallel resonance	5		20	pF
ESR12&13	Crystal ESR (12 and 13 MHz) ⁽¹⁾			80	Ω
ESR16.8&19.2	Crystal ESR (16.8 and 19.2 MHz) ⁽¹⁾			50	Ω
C_o	Crystal shunt capacitance	1		7	pF
L_m	Crystal motional inductance for $f_p = 12$ MHz			35	mH
C_m	Crystal motional capacitance	5		100	fF
DL	Crystal drive level			0.5	mW
R_{bias}	Internal bias resistor	30	120	300	kΩ
R_{pdXI}	Pulldown resistor on <code>sys_xtalin</code> when oscillator is disabled			5	kΩ

- (1) Measured with the load capacitance specified by the crystal manufacturer. This load is defined by the foot capacitances tied in series. If $C_L = 20$ pF, then both foot capacitors will be $C_{f1} = C_{f2} = 40$ pF. Parasitic capacitance from package and board must also be taken in account.
- (2) The crystal motional resistance R_m is related to the equivalent series resistance (ESR) by the following formula:

$$ESR = R_m \left(1 + \frac{C_o}{C_L} \right)^2$$

When selecting a crystal, the system design must take into account the temperature and aging characteristics of a crystal versus the user environment and expected lifetime of the system. [Table 4-3](#) details the switching characteristics of the oscillator and the input requirements of the 12-, 13-, 16.8-, or 19.2-MHz input clock.

Table 4-3. Base Oscillator Switching Characteristics

NAME	DESCRIPTION	MIN	TYP	MAX	UNIT
f_p	Oscillation frequency	12, 13, 16.8, or 19.2			MHz
t_{sX}	Start-up time ⁽¹⁾⁽²⁾	8			ms

- (1) Start-up time defined as time interval between oscillator control signal release and `sys_xtalin` amplitude at 50% of its final value (`vdd` and `vdds` supplies ramped and stable). The start-up time can be performed in function of the crystal characteristics. 8-ms minimum only when using the internal oscillator; it is programmable after reset for wake-up. At power-on reset, the time is adjustable using the pin itself. The reset must be released when the oscillator or clock source is stable. Before the processor boots up and the oscillator is set to bypass mode, there is a start-up time when the internal oscillator is in application mode and receives a square wave. The start-up time in this case is about 100 μs.
- (2) For $f_p = 12$ or 13 MHz: $C_L = 13.5$ pF and $L_m = 35$ mH
 For $f_p = 16.8$ or 19.2 MHz: $C_L = 9$ pF and $L_m = 15$ mH

4.1.3 Clock Squarer Input Description

A 1.8-V CMOS clock squarer is another source that can supply a 12-, 13-, 16.8-, 19.2-, 26-, or 38.4-MHz clock to the OMAP3515/03. An analog clock squarer function converts a low-amplitude sinusoidal clock into a low-jitter digital signal. It can be connected to input pin `sys_xtalin` (`sys_xtalout` unconnected). [Figure 4-3](#) illustrates the effective connections.

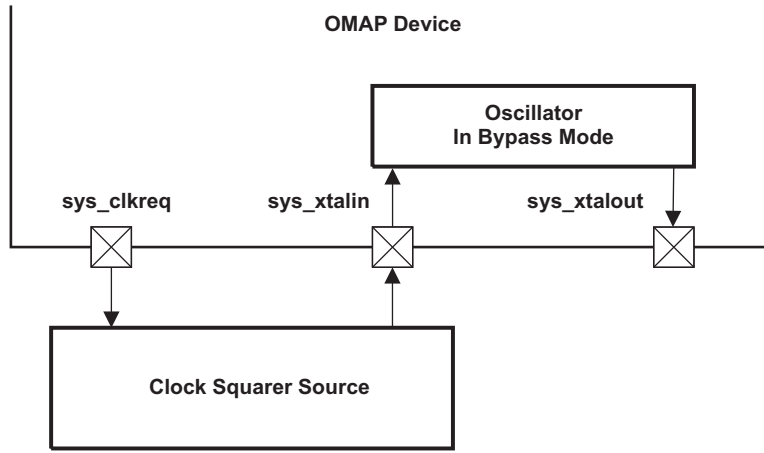

030-010

Figure 4-3. Clock Squarer Source Connection

To connect a digital clock source, the oscillator is configured in bypass mode⁽¹⁾. The sys_clkreq⁽²⁾ pin is an OMAP3515/03 output which can be used to switch the clock source on or off.

1. Pin sys_xtalout is not used in this mode. It must be left unconnected.
2. Once the system is powered up, the clock squarer source or crystal oscillator source can be applied; however, this affects the performance. The input source must be configured after power up to attain the desired system requirements.

Table 4-4 summarizes the electrical constraints required by the clock squarer used in the fundamental mode of operation.

Table 4-4. Base Oscillator Electrical Characteristics (in Bypass Mode)

NAME	DESCRIPTION	MIN	TYP	MAX	UNIT
f	Frequency ⁽¹⁾	12, 13, 16.8, 19.2, 26, or 38.4			MHz
t _{sX}	Start-up time	(2)			ms
R _{pdXI}	Pulldown resistor on sys_xtalin when oscillator is disabled			5	kΩ
I _{DDQ}	Current consumption on VDD5 when sys_xtalin = 0 and in power-down mode			1	μA

(1) Measured with the load capacitance specified by the manufacturer. Parasitic capacitance from package and board must also be taken in account.

(2) Before the processor boots up and the oscillator is set to bypass mode, there is a start-up time when the internal oscillator is in application mode and receives a square wave. The start-up time in this case is about 100 μs.

Table 4-5 details the input requirements of the 12-, 13-, 16.8-, 19.2-, 26-, or 38.4-MHz input clock.

Table 4-5. 12-, 13-, 16.8-, 19.2-, 26-, or 38.4-MHz Input Clock Squarer Timing Requirements

NAME	DESCRIPTION		MIN	TYP	MAX	UNIT
OCS0	1 / t _{c(xtalin)}	Frequency, sys_xtalin	12, 13, 16.8, 19.2, 26, or 38.4			MHz
OCS1	t _{w(xtalin)}	Pulse duration, sys_xtalin low or high	0.45 * t _{c(xtalin)}		0.55 * t _{c(xtalin)}	ns
OCS2	t _{J(xtalin)}	Peak-to-peak jitter ⁽¹⁾ , sys_xtalin	–1%		1%	
OCS3	t _{R(xtalin)}	Rise time, sys_xtalin			3.6	ns
OCS4	t _{F(xtalin)}	Fall time, sys_xtalin			3.6	ns
OCS5	t _{J(xtalin)}	Frequency stability, sys_xtalin			±25	ppm

(1) Peak-to-peak jitter is defined as the difference between the maximum and the minimum output periods on a statistical population of 300 period samples. The sinusoidal noise is added on top of the vdds supply voltage.

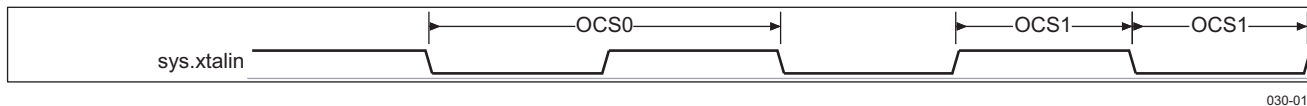

030-011

Figure 4-4. Crystal Oscillator in Bypass Mode

4.1.4 External 32-kHz CMOS Input Clock

A 32.768-kHz clock signal (often abbreviated to 32-kHz) can be supplied by an external 1.8-V CMOS signal on pin sys_32k.

Table 4-6 summarizes the electrical constraints imposed to the clock source.

Table 4-6. 32-kHz Input Clock Source Electrical Characteristics

NAME	DESCRIPTION	MIN	TYP	MAX	UNIT
f	Frequency	32.768			kHz
C _i	Input capacitance		0.44		pF
	Amplitude of input clock	1.71	1.8 ⁽¹⁾	1.89	V

(1) Voltage stress up to the maximum voltage values shown above operation at T_j of 25°C.

Table 4-7 details the input requirements of the 32-kHz input clock.

Table 4-7. 32-kHz Input Clock Source Timing Requirements

NAME	DESCRIPTION		MIN	TYP	MAX	UNIT
CK0	1 / t _{c(32k)}	Frequency, sys_32k	32.768			kHz
CK1	t _{w(32k)}	Pulse duration, sys_32k low or high	0.40 * t _{c(32k)}		0.60 * t _{c(32k)}	ns
CK3	t _{R(32k)}	Rise time, sys_32k			20	ns
CK4	t _{F(32k)}	Fall time, sys_32k			20	ns
CK5	t _{J(32k)}	Frequency stability, sys_32k			±200	ppm

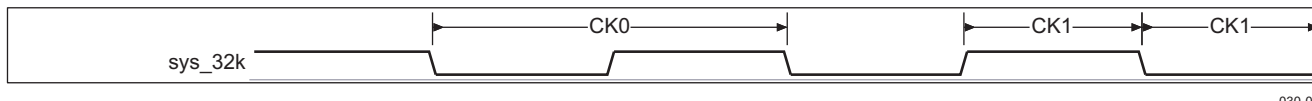

030-012

Figure 4-5. 32-kHz CMOS Clock

4.1.5 External sys_altclk CMOS Input Clock

A 48- or 54-MHz clock signal can be supplied by an external 1.8-V CMOS signal on pin sys_altclk.

Table 4-8 summarizes the electrical constraints imposed by the clock source.

Table 4-8. 48- or 54-MHz Input Clock Source Electrical Characteristics

NAME	DESCRIPTION	MIN	TYP	MAX	UNIT
f	Frequency	48 or 54			MHz
C _i	Input capacitance		0.74		pF
	Amplitude of input clock	1.71	1.8 ⁽¹⁾	1.89	V

(1) Voltage stress up to the maximum voltage values shown above operation at T_j of 25°C.

Table 4-9 details the input requirements of the 48- or 54-MHz input clock.

Table 4-9. 48- or 54-MHz Input Clock Source Timing Requirements

NAME		DESCRIPTION	MIN	TYP	MAX	UNIT
ALT0	$1 / t_{c(altclk)}$	Frequency, sys_altclk	48 or 54			MHz
ALT1	$t_{w(altclk)}$	Pulse duration, sys_altclk low or high	$0.40 * t_{c(altclk)}$		$0.60 * t_{c(altclk)}$	ns
ALT2	$t_{j(altclk)}$	Peak-to-peak jitter ⁽¹⁾ , sys_altclk	–1%		1%	
ALT3	$t_{R(altclk)}$	Rise time, sys_altclk			5	ns
ALT4	$t_{F(altclk)}$	Fall time, sys_altclk			5	ns
ALT5	$t_{J(altclk)}$	Frequency stability, sys_altclk			± 50	ppm

(1) Peak-to-peak jitter is defined as the difference between the maximum and the minimum output periods on a statistical population of 300 period samples. The sinusoidal noise is added on top of the vdds supply voltage.

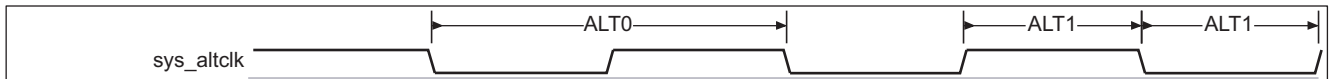

030-013

Figure 4-6. Alternate CMOS Clock

4.2 Output Clock Specifications

Two output clocks (pin sys_clkout1 and pin sys_clkout2) are available:

- sys_clkout1 can output the oscillator clock (12, 13, 16.8, 19.2, 26, or 38.4 MHz) at any time. It can be controlled by software or externally using sys_clkreq control. When the device is in the off state, the sys_clkreq can be asserted to enable the oscillator and activate the sys_clkout1 without waking up the device. The off state polarity of sys_clkout1 is programmable.
- sys_clkout2 can output sys_clk (12, 13, 16.8, 19.2, 26, or 38.4 MHz), CORE_CLK (core DPLL output, 332 MHz maximum), APLL-96 MHz, or APLL-54 MHz. It can be divided by 2, 4, 8, or 16 and its off state polarity is programmable. This output is active only when the core domain is active.

Table 4-10 summarizes the sys_clkout1 output clock electrical characteristics.

Table 4-10. sys_clkout1 Output Clock Electrical Characteristics

NAME	DESCRIPTION		MIN	TYP	MAX	UNIT
f	Frequency		12, 13, 16.8, 19.2, 26, or 38.4			MHz
C _i	Load capacitance ⁽¹⁾	f(max) = 38.4 MHz		70		pF
		f(max) = 26 MHz		125		
	Amplitude of output clock		1.71	1.8 ⁽²⁾	1.89	V

(1) The load capacitance is adapted to a frequency.

(2) Voltage stress up to the maximum voltage values shown above operation at T_J of 25°C.

Table 4-11 details the sys_clkout1 output clock timing characteristics.

Table 4-11. sys_clkout1 Output Clock Switching Characteristics

NAME	DESCRIPTION		MIN	TYP	MAX	UNIT
f	1 / CO0	Frequency	12, 13, 16.8, 19.2, 26, or 38.4			MHz
CO1	t _w (CLKOUT1)	Pulse duration, sys_clkout1 low or high	0.40 *		0.60 *	ns
			t _c (CLKOUT1)		t _c (CLKOUT1)	
CO2	t _R (CLKOUT1)	Rise time, sys_clkout1 ⁽¹⁾			3.31	ns
CO3	t _F (CLKOUT1)	Fall time, sys_clkout1 ⁽¹⁾			3.31	ns

(1) With a load capacitance of 25 pF.

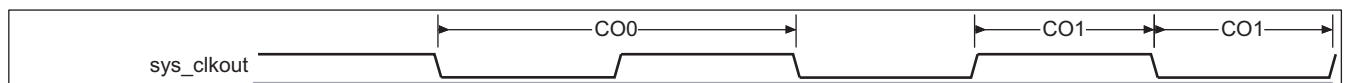

030-014

Figure 4-7. sys_clkout1 System Output Clock

Table 4-12 summarizes the sys_clkout2 output clock electrical characteristics.

Table 4-12. sys_clkout2 Output Clock Electrical Characteristics

NAME	DESCRIPTION		MIN	TYP	MAX	UNIT
f	Frequency				322	MHz
C _i	Load capacitance ⁽¹⁾	f(max) = 166 MHz		8		pF
		f(max) = 96 MHz		20		
		f(max) = 65 MHz		25		
	Amplitude of output clock		1.71	1.8 ⁽²⁾	1.89	V

(1) The load capacitance is adapted to a frequency.

(2) Voltage stress up to the maximum voltage values shown above, operation at T_J = 25°C.

Table 4-13 details the sys_clkout2 output clock timing characteristics.

Table 4-13. sys_clkout2 Output Clock Switching Characteristics

NAME	DESCRIPTION		MIN	TYP	MAX	UNIT
f	1 / CO0	Frequency			322	MHz
CO1	$t_{w(\text{CLKOUT2})}$	Pulse duration, sys_clkout2 low or high	$0.40 * t_{c(\text{CLKOUT2})}$		$0.60 * t_{c(\text{CLKOUT2})}$	ns
CO2	$t_{R(\text{CLKOUT2})}$	Rise time, sys_clkout2 ⁽¹⁾			3.7	ns
CO3	$t_{F(\text{CLKOUT2})}$	Fall time, sys_clkout2 ⁽¹⁾			4.3	ns

(1) With a load capacitance of 25 pF.

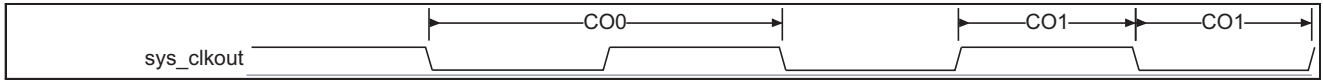

030-015

Figure 4-8. sys_clkout2 System Output Clock

4.3 DPLL and DLL Specifications

The OMAP3515/03 integrates six DPLLs and a DLL. The PRM and CM drive five of them, while the sixth (not supported) is controlled by the display controller.

The five main DPLLs are:

- DPLL1 (MPU)
- DPLL2 (not supported on OMAP3515/03 devices)
- DPLL3 (Core)
- DPLL4 (Peripherals)
- DPLL5 (Second Peripherals DPLL)

Figure 4-9 illustrates the DLL and DPLL implementation.

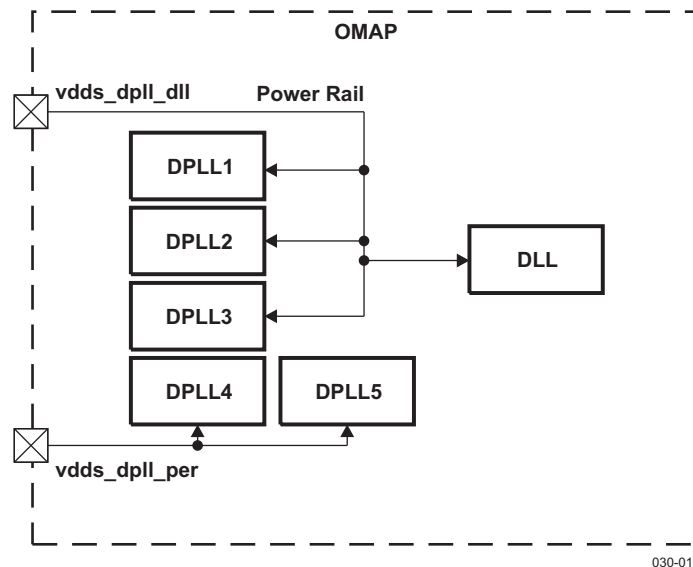

030-016

(1) DPLL2 is not supported on OMAP3515/03 devices.

Figure 4-9. DPLL and DLL Implementation

For more information on the OMAP3530/25 Applications Processor DPLLs and clocking structure, see the Power, Reset, and Clock management (PRCM) chapter of the *OMAP35xx Applications Processor TRM* (literature number [SPRUFA5](#)).

4.3.1 Digital Phase-Locked Loop (DPLL)

The DPLL provides all interface clocks and some functional clocks (such as the processor clocks) of the OMAP3515/03 device.

DPLL1 and DPLL2 get an always-on clock used to produce the synthesized clock. They get a high-speed bypass clock used to switch the DPLL output clock on this high-speed clock during bypass mode.

The high-speed bypass clock is an L3 divided clock (programmable by 1 or 2) that saves DPLL processor power consumption when the processor does not need to run faster than the L3 clock speed, or optimizes performance during frequency scaling.

Each DPLL synthesized frequency is set by programming M (multiplier) and N (divider) factors. In addition, all DPLL outputs can be controlled by an independent divider (M2 to M6).

The clock generating DPLLs of the OMAP3515/03 device have following features:

- Independent power domain per DPLL
- Controlled by clock-manager (CM)

- Fed with always-on system clock with independent gating control per DPLL
- Analog part supplied through dedicated power supply (1.8 V) and an embedded LDO to get rid of 1-MHz noise
- Up to five independent output dividers for simultaneous generation of multiple clock frequencies

4.3.1.1 DPLL1 (MPU)

DPLL1 is located in the MPU subsystem and supplies all clocks of the subsystem. All MPU subsystem clocks are internally generated in the subsystem. When the core domain is on, it can use the DPLL3 (CORE DPLL) output as a high-frequency bypass input clock.

4.3.1.2 DPLL3 (CORE)

DPLL3 supplies all interface clocks and also a few module functional clocks. It can be also source of the emulation trace clock. It is located in the core domain area. All interface clocks and a few module functional clocks are generated in the CM. When the core domain is on, it can be used as a bypass input to DPLL1 and DPLL2.

4.3.1.3 DPLL4 (Peripherals)

DPLL4 generates clocks for the peripherals. It supplies five clock sources: 96-MHz functional clocks to subsystems and peripherals, 54 MHz to TV DAC, display functional clock, camera sensor clock, and emulation trace clock. It is located in the core domain area. All interface clocks and few module functional clocks are generated in the CM. Its outputs to the DSS, PER, and EMU domains are propagated with always-on clock trees.

4.3.1.4 DPLL5 (Second peripherals DPLL)

DPLL5 supplies the 120-MHz functional clock to the CM.

4.3.2 Delay-Locked Loops (DLL)

The SDRC includes analog-controlled delay technology for interfacing high-speed mobile DDR memory components. For more information, see the SDRC-GPMC chapter of the *OMAP35xx ES2.0 Technical Reference Manual (TRM)* [literature number TBD]. A DLL is a calibration module used on dynamic track of voltage and temperature variations, as well as to compensate the silicon process dispersion.

The SDRC DLL has four modes of operation:

1. APPLICATION MODE 0: used to generate 72° delay
2. APPLICATION MODE 1: used to generate 90° delay
3. MODEMAXDELAY: used for low frequency operation where we do not have the requirement of accurate 72° or 90° phase shift
4. IDLE MODE: a low-power state that allows the DLL to gain lock quickly on exit from this mode

4.3.3 DPLLs and DLL Characteristics

Several specifications characterize the six DPLLs.

Table 4-14 summarizes the DPLL characteristics and assumes testing over recommended operating conditions.

Table 4-14. DPLL Characteristics

NAME	PARAMETER	MIN	TYP	MAX	UNIT	COMMENTS ⁽⁴⁾
vdds_dp1l_per		1.71	1.8	1.89	V	At module pins (+5%, –10%)
vdds_dp1l_dll		1.71	1.8	1.89	V	
T _J	Junction temperature	–40	25	107	°C	Will not unlock after lock over this range for slow temperature drifts
t _{lock}	Frequency lock time ⁽²⁾	71.4		200	μs	150 FINT cycles; FREQSEL3 = 0
		37.1		104	μs	780 FINT cycles; FREQSEL3 = 1
p _{lock}	Phase lock time	166.7		466.7	μs	350 FINT cycles; FREQSEL3 = 0
		46.7		130.7	μs	980 FINT cycles; FREQSEL3 = 1
t _{relock}	Relock time – frequency lock ⁽³⁾	4.8		13.3	μs	10 FINT cycles Lowcurrstby = 0; FREQSEL3 = 0
		4.8		13.3	μs	100 FINT cycles Lowcurrstby = 0; FREQSEL3 = 1
		19		53.3	μs	40 FINT cycles Lowcurrstby = 1; FREQSEL3 = 0
		19		53.3	μs	400 FINT cycles Lowcurrstby = 1; FREQSEL3 = 1
p _{relock}	Relock time – Phase lock ⁽³⁾	71.4		200	μs	150 FINT cycles Lowcurrstby = 0; FREQSEL3 = 0
		11.9		33.3	μs	250 FINT cycles Lowcurrstby = 0; FREQSEL3 = 1
		95.2		266.7	μs	200 FINT cycles Lowcurrstby = 1; FREQSEL3 = 0
		26.7		74.7	μs	560 FINT cycles Lowcurrstby = 1; FREQSEL3 = 1

- (1) Input frequencies below 0.75 MHz are possible with performance penalty.
- (2) Maximum frequency for nominal conditions. Speed binning possible above fmax.
- (3) Relock time assumes typical operating conditions, 4°C maximum temperature drift (see the Functional Specification for more detailed information).
- (4) f_{regsel} needs to be programmed accordingly to reference clock and DPLL divider (register setting), Lowcurrstby depends on the targeted DPLL power state (dynamic).
 Lowcurrstby = 0 then DPLL is in normal mode
 Lowcurrstby = 1 then DPLL is in low-power mode

Table 4-15 shows the DPLL1 clock frequency ranges.

Note: The DPLL1 clock frequency ranges depend on the V_{DD1} (vdd_mpu) operating point.

Table 4-15. DPLL1 Clock Frequency Ranges

Clock Signal	Description	Max	Unit
DPLL1_ALWON_FCLK	DPLL1 reference clock input, taken from PRM SYS_CLK.	TBD	MHz
DPLL1_FCLK	DPLL1 high-frequency bypass clock input, taken from CM CORE_CLK.	TBD	MHz

Table 4-15. DPLL1 Clock Frequency Ranges (continued)

Clock Signal	Description		Max	Unit
DPLL1: CLKOUTX2	DPLL1 internal clock signal, generated through DPLL1 Multiplier and Divider.	OPP5	600	MHz
		OPP4	550	MHz
		OPP3	500	MHz
		OPP2	500	MHz
		OPP1	500	MHz
MPU_CLK	DPLL1 output clock, generated from CLKOUT_M2X2.	OPP5	600	MHz
		OPP4	550	MHz
		OPP3	500	MHz
		OPP2	250	MHz
		OPP1	125	MHz

Table 4-16 through Table 4-18 show the DPLL3 clock frequency ranges.

Note: The DPLL3 clock frequency ranges depend on the VDD2 (vdd_core) operating point and the L3 clock speed configuration.

Table 4-16. DPLL3 Clock Frequency Ranges, VDD2 OPP3

Clock Signal	Description	Config 1 (166 MHz)		Config 2 (133 MHz)		Config 3 (100 MHz)		Unit
		Min	Max	Min	Max	Min	Max	
DPLL3_ALWON_FCLK	DPLL3 input reference clock, generated by PRM.	TBD	TBD	TBD	TBD	TBD	TBD	MHz
DPLL3: CLKOUTX2	DPLL3 internal clock signal, generated through DPLL3 Multiplier and Divider.	50	664	50	532	50	400	MHz
DPLL3: CLKOUT	DPLL3 internal clock signal, generated by dividing DPLL3 CLKOUTX2 by 2.	25	332	25	266	25	200	MHz
CM: CORE_CLK	Output of clock manager (CM), generated directly from DPLL3 CLKOUT_M2.	-	332	-	266	-	200	MHz
CM: L3_ICLK	Output of clock manager (CM), generated using DPLL3 CLKOUT_M2X2 and divider.	-	166	-	133	-	100	MHz
CM: L4_ICLK	Output of clock manager (CM), generated using CM L3_ICLK and divider.	-	83	-	66.5	-	50	MHz
SGX	SGX input clock, taken from CM CORE_CLK.	-	110.67	-	88.67	-	66.67	MHz
SDRC	SDRC input clock, taken from CM L3_ICLK.	-	166	-	133	-	100	MHz
GPMC	GPMC input clock, taken from CM L3_ICLK.	-	83	-	66.5	-	100	MHz

Table 4-17. DPLL3 Clock Frequency Ranges, VDD2 OPP2

Clock Signal	Description	Config 1 (83 MHz)		Config 2 (100 MHz)		Unit
		Min	Max	Min	Max	
DPLL3_ALWON_FCLK	DPLL3 input reference clock, generated by PRM.	TBD	TBD	TBD	TBD	MHz
DPLL3: CLKOUTX2	DPLL3 internal clock signal, generated through DPLL3 Multiplier and Divider.	50	664	50	400	MHz
DPLL3: CLKOUT	DPLL3 internal clock signal, generated by dividing DPLL3 CLKOUTX2 by 2.	25	332	25	200	MHz

Table 4-17. DPLL3 Clock Frequency Ranges, VDD2 OPP2 (continued)

Clock Signal	Description	Config 1 (83 MHz)		Config 2 (100 MHz)		Unit
		Min	Max	Min	Max	
CM: CORE_CLK	Output of clock manager (CM), generated directly from DPLL3 CLKOUT_M2.	-	166	-	200	MHz
CM: L3_ICLK	Output of clock manager (CM), generated using DPLL3 CLKOUT_M2X2 and divider.	-	83	-	100	MHz
CM: L4_ICLK	Output of clock manager (CM), generated using CM L3_ICLK and divider.	-	41.5	-	50	MHz
SGX	SGX input clock, taken from CM CORE_CLK.	-	55.53	-	66.67	MHz
SDRC	SDRC input clock, taken from CM L3_ICLK.	-	83	-	100	MHz
GPMC	GPMC input clock, taken from CM L3_ICLK.	-	83	-	50	MHz

Table 4-18. DPLL3 Clock Frequency Ranges, VDD2 OPP1

Clock Signal	Description	Config 1 (400 MHz)		Unit
		Min	Max	
DPLL3_ALWON_FCLK	DPLL3 input reference clock, generated by PRM.	TBD	TBD	MHz
DPLL3: CLKOUTX2	DPLL3 internal clock signal, generated through DPLL3 Multiplier and Divider.	50	664	MHz
DPLL3: CLKOUT	DPLL3 internal clock signal, generated by dividing DPLL3 CLKOUTX2 by 2.	25	332	MHz
CM: CORE_CLK	Output of clock manager (CM), generated directly from DPLL3 CLKOUT_M2.	-	83	MHz
CM: L3_ICLK	Output of clock manager (CM), generated using DPLL3 CLKOUT_M2X2 and divider.	-	41.5	MHz
CM: L4_ICLK	Output of clock manager (CM), generated using CM L3_ICLK and divider.	-	20.75	MHz
SGX	SGX input clock, taken from CM CORE_CLK.	-	N/A	MHz
SDRC	SDRC input clock, taken from CM L3_ICLK.	-	41.5	MHz
GPMC	GPMC input clock, taken from CM L3_ICLK.	-	41.5	MHz

Table 4-19 summarizes the DLL characteristics.

Table 4-19. DLL Characteristics

PARAMETER	MIN	NOM	MAX	UNIT	COMMENTS
Supply voltage vdds_dpll_dll	1.71	1.8	1.89	V	
Junction operating temperature	-40	25	107	°C	
Input clock frequency	66	120	133	MHz	APPLICATION MODE 0
	83	120	166		APPLICATION MODE 1
Input load ⁽²⁾			15	fF	
Lock time ⁽³⁾			500	Clocks	
Relock time (Mode transitions through idle mode)			500	ns	IDLE to MODEMAXDELAY
		150	372	Clocks	IDLE to APPLICATION MODE 1 or 0
		1	2	µs	IDLE to APPLICATION MODE @133 MHz
		1	1.5	µs	IDLE to APPLICATION MODE @166 MHz

(1) May be lower due to SmartReflex operation.

(2) This parameter is design goal and is not tested on silicon.

(3) Lock signal would go high from power down within 500 clocks. Lock signal switches to low state when the input clock is switched off after 3 µs.

4.3.4 DPLL and DLL Noise Isolation

The DPLL and DLL require dedicated power supply pins to isolate the core analog circuit from the switching noise generated by the core logic that can cause jitter on the clock output signal. Guard rings are added to the cell to isolate it from substrate noise injection.

The vdd supplies are the most sensitive to noise; decoupling capacitance is recommended below the supply rails. The maximum input noise level allowed is 30 mV_{PP} for frequencies below 1 MHz.

Figure 4-10 illustrates an example of a noise filter.

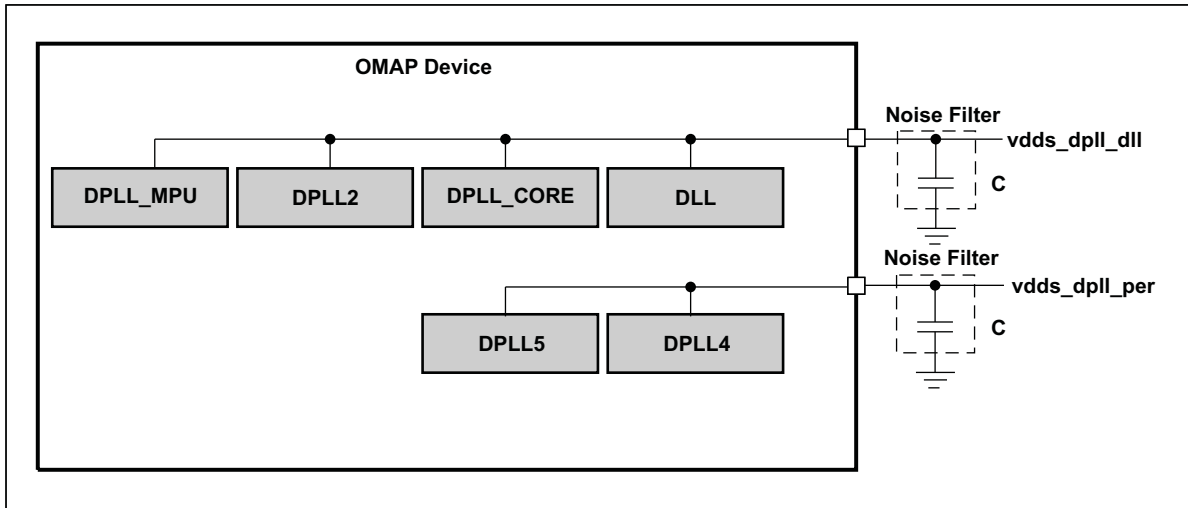

030-017

- (1) DPLL2 is not supported on OMAP3515/03 devices.

Figure 4-10. DPLL and DLL Noise Filter⁽¹⁾

Table 4-20 specifies the noise filter requirements.

Table 4-20. DPLL and DLL Noise Filter Requirements

NAME	MIN	TYP	MAX	UNIT
Filtering capacitor		100		nF

- (1) The capacitors must be inserted between power and ground as close as possible.
- (2) This circuit is provided only as an example.
- (3) The filter must be located as close as possible to the device.
- (4) No filtering required if noise is below 10 mV_{PP}.

5 VIDEO DAC SPECIFICATIONS

A dual-display interface equips the OMAP3515/03 processor. This display subsystem provides the necessary control signals to interface the memory frame buffer directly to the external displays (TV-set). Two (one per channel) 10-bit current steering DACs are inserted between the DSS and the TV set to generate the video analog signal. One of the video DACs also includes TV detection and power-down mode. Figure 5-1 illustrates the OMAP3515/03 DAC architecture. For more information, see the DSS chapter of the *OMAP35xx ES2.0 Technical Reference Manual (TRM)* [literature number TBD].

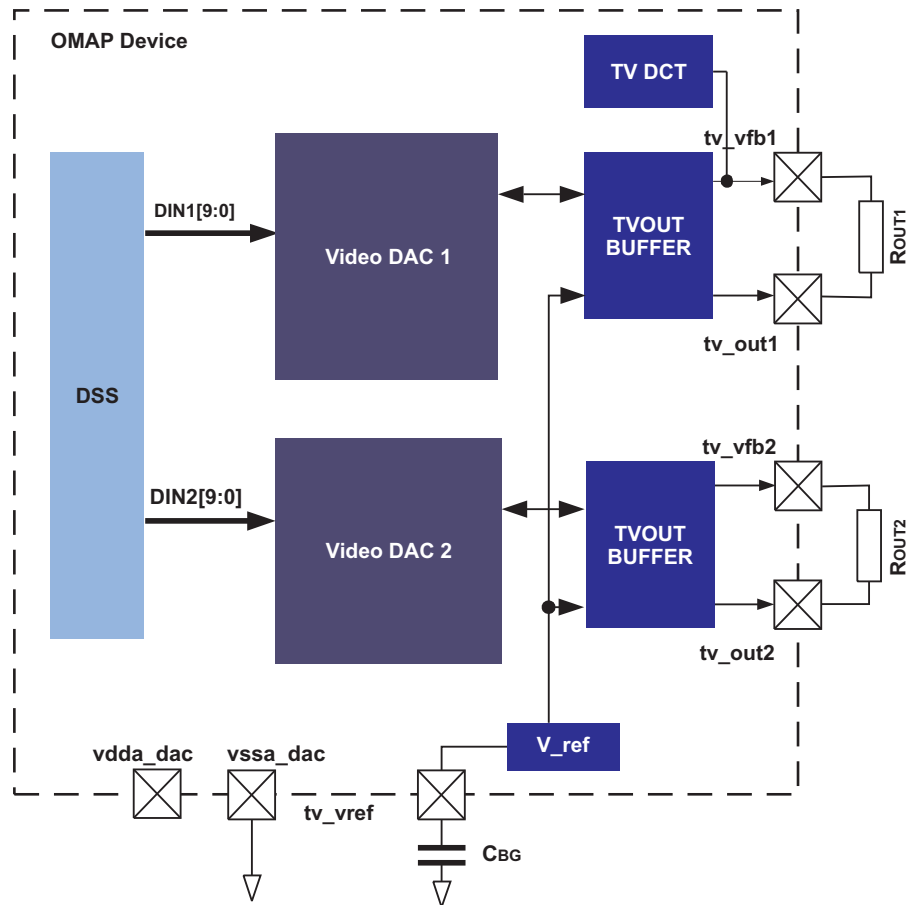

030-018

Figure 5-1. Video DAC Architecture

The following paragraphs detail the 10-bit DAC interface pinout, static and dynamic specifications, and noise requirements. The operating conditions and absolute maximum ratings are detailed in Table 5-2 and Table 5-4.

5.1 Interface Description

Table 5-1 summarizes the external pins of the video DAC.

Table 5-1. External Pins of 10-bit Video DAC

PIN NAME	I/O	DESCRIPTION	
tv_out1	O	TV analog output composite	DAC1 video output. An external resistor is connected between this node and tv_vfb1. The nominal value of ROUT1 is 1650 Ω. Finally, note that this is the output node that drives the load (75 Ω).

Table 5-1. External Pins of 10-bit Video DAC (continued)

PIN NAME	I/O	DESCRIPTION	
tv_out2	O	TV analog output S-VIDEO	DAC2 video output. An external resistor is connected between this node and tv_vfb2. The nominal value of ROUT2 is 1650 Ω . Finally, note that this is the output node that drives the load (75 Ω).
tv_vref	I	Reference output voltage from internal bandgap	A decoupling capacitor (CBG) needs to be connected for optimum performance.
tv_vfb1	O	Amplifier feedback node	Amplifier feedback node. An external resistor is connected between this node and tv_out1. The nominal value of ROUT1 is 1650 Ω (1%).
tv_vfb2	O	Amplifier feedback node	Amplifier feedback node. An external resistor is connected between this node and tv_out2. The nominal value of ROUT2 is 1650 Ω (1%).

5.2 Electrical Specifications Over Recommended Operating Conditions

(T_{MIN} to T_{MAX} , $v_{dda_dac} = 1.8\text{ V}$, $R_{OUT1/2} = 1650\ \Omega$, $R_{LOAD} = 75\ \Omega$, unless otherwise noted)

Table 5-2. DAC – Static Electrical Specification

PARAMETER		CONDITIONS/ASSUMPTIONS	MIN	TYP	MAX	UNIT
R	Resolution			10		Bits
DC ACCURACY						
INL ⁽¹⁾	Integral nonlinearity		–1		1	LSB
DNL ⁽²⁾	Differential nonlinearity		–1		1	LSB
ANALOG OUTPUT						
-	Full-scale output voltage	$R_{LOAD} = 75\ \Omega$	0,7	0.88	1	V
-	Output offset voltage			50		mV
-	Output offset voltage drift			20		mV/°C
-	Gain error		–17		19	% FS
R_{VOUT}	Output impedance		67.5	75	82.5	Ω
REFERENCE						
V_{REF}	Reference voltage range		0.525	0.55	0.575	V
-	Reference noise density	100-kHz reference noise bandwidth		129		
R_{SET}	Full-scale current adjust resistor		3700	4000	4200	Ω
P_{SRR}	Reference PSRR ⁽³⁾ (Up to 6 MHz)			40		dB
POWER CONSUMPTION						
$I_{vdda-up}$	Analog Supply Current ⁽⁴⁾	2 channels, no load		8		mA
-	Analog supply driving a 75- Ω load (RMS)	2 channels		50		mA
$I_{vdda-up}$ (peak)	Peak analog supply current:	Lasts less than 1 ns		60		mA
I_{vdd-up}	Digital supply current ⁽⁵⁾	Measured at $f_{CLK} = 54\text{ MHz}$, $f_{OUT} = 2\text{ MHz}$ sine wave, $v_{dd} = 1.3\text{ V}$		2		mA
I_{vdd-up} (peak)	Peak digital supply current ⁽⁶⁾	Lasts less than 1 ns		2.5		mA
$I_{vdda-down}$	Analog power at power-down	$T = 30^\circ\text{C}$, $v_{dda} = 1.8\text{ V}$		1.5		mA
$I_{vdd-down}$	Digital power at power-down	$T = 30^\circ\text{C}$, $v_{dd} = 1.3\text{ V}$		1		mA

(1) The INL is measured at the output of the DAC (accessible at an external pin during bypass mode).

(2) The DNL is measured at the output of the DAC (accessible at an external pin during bypass mode).

(3) Assuming a capacitor of 0.1 μF at the tv_ref node.

(4) The analog supply current I_{vdda} is directly proportional to the full-scale output current IFS and is insensitive to f_{CLK} .

(5) The digital supply current I_{VDD} is dependent on the digital input waveform, the DAC update rate f_{CLK} , and the digital supply VDD.

(6) The peak digital supply current occurs at full-scale transition for duration less than 1 ns.

(T_{MIN} to T_{MAX} , $v_{dda_dac} = 1.8\text{ V}$, $R_{OUT1/2} = 1650\ \Omega$, $R_{LOAD} = 75\ \Omega$, unless otherwise noted)

Table 5-3. Video DAC – Dynamic Electrical Specification

	PARAMETER	CONDITIONS/ASSUMPTIONS	MIN	TYP	MAX	UNIT
$f_{CLK}^{(1)}$	Output update rate	Equal to input clock frequency		54		MHz
	Clock jitter	rms clock jitter required in order to assure 10-bit accuracy			40	ps
	Attenuation at 5.1 MHz	Corner frequency for signal	0.1	0.5	1.5	dB
	Attenuation at 54 MHz ⁽¹⁾	Image frequency	25	30	33	dB
t_{ST}	Output settling time	Time from the start of the output transition to output within ± 1 LSB of final value.		85		ns
t_{Rout}	Output rise time	Measured from 10% to 90% of full-scale transition		25		ns
t_{Fout}	Output fall time	Measured from 10% to 90% of full-scale transition		25		ns
BW	Signal bandwidth			6		MHz
	Differential gain ⁽²⁾			1.5%		
	Differential phase ⁽²⁾			1		deg.
SFDR	Within bandwidth	$f_{CLK} = 54\text{ MHz}$, $f_{OUT} = 1\text{ MHz}$		45		dB
SNR	Signal-to-noise ratio 1 kHz to 6 MHz bandwidth	$f_{CLK} = 54\text{ MHz}$, $f_{OUT} = 1\text{ MHz}$		55 ⁽³⁾		dB
PSRR	Power supply rejection ratio	Up to 6 MHz		20 ⁽⁴⁾		dB
Crosstalk	Between the two video channels			-50	-40	dB

- (1) For internal input clock information, For more information, see the DSS chapter of the *OMAP35xx ES2.0 Technical Reference Manual (TRM)* [literature number TBD].
- (2) The differential gain and phase value is for dc coupling. Note that there is degradation for the ac coupling.
- (3) The SNR value is for dc coupling. Note that there is a 6-dB degradation for ac coupling.
- (4) The PSSR value is for dc coupling. Note that there is a 10-dB degradation for ac coupling.

PRODUCT PREVIEW

5.3 Analog Supply (vdda_dac) Noise Requirements

In order to assure 10-bit accuracy of the DAC analog output, the analog supply vdda_dac has to meet the noise requirements stated in this section.

The DAC Power Supply Rejection Ratio is defined as the relative variation of the full-scale output current divided by the supply variation. Thus, it is expressed in percentage of Full-Scale Range (FSR) per volt of

$$PSRR_{DAC} = \frac{100 \cdot \frac{\Delta I_{OUT}}{I_{OUTFS}}}{V_{AC}} \quad \left[\frac{\% FSR}{V} \right]$$

supply variation as shown in the following equation:

Depending on frequency, the PSRR is defined in [Table 5-4](#).

Table 5-4. Video DAC – Power Supply Rejection Ratio

Supply Noise Frequency	PSRR % FSR/V
0 to 100 kHz	1
> 100 kHz	The rejection decreases 20 dB/dec. Example: at 1 MHz the PSRR is 10% of FSR/V

A graphic representation is shown in [Figure 5-2](#).

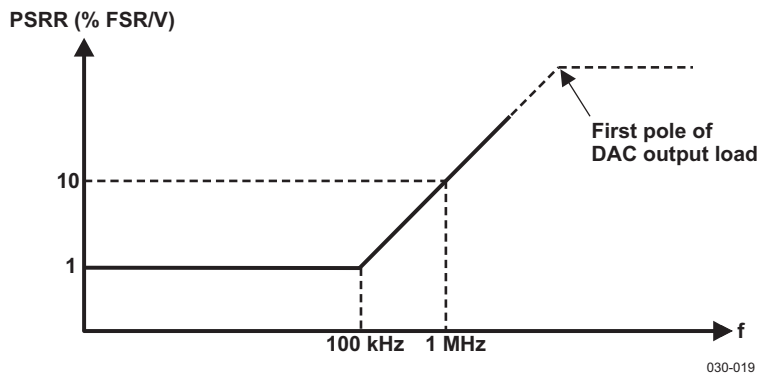

Figure 5-2. Video DAC – Power Supply Rejection Ratio

To ensure that the DAC SFDR specification is met, the PSRR values and the clock jitter requirements translate to the following limits on vdda_dac (for the Video DAC).

The maximum peak-to-peak noise on vdda (ripple) is defined in [Table 5-5](#):

Table 5-5. Video DAC – Maximum Peak-to-Peak Noise on vdda_dac

Tone Frequency	Maximum Peak-to-Peak Noise on vdda_dac
0 to 100 kHz	< 30 mVpp
> 100 kHz	Decreases 20 dB/dec. Example: at 1 MHz the maximum is 3 mVpp

The maximum noise spectral density (white noise) is defined in [Table 5-6](#):

Table 5-6. Video DAC – Maximum Noise Spectral Density

Supply Noise Bandwidth	Maximum Supply Noise Density
0 to 100 kHz	< 20 $\mu\text{V} / \sqrt{\text{Hz}}$
> 100 kHz	Decreases 20 dB/dec. Example: at 1 MHz the maximum noise density is 2 $\mu\text{V} / \sqrt{\text{Hz}}$

Because the DAC PSRR deteriorates at a rate of 20 dB/dec after 100 kHz, it is highly recommended to have vdda_dac low pass filtered (proper decoupling) (see the illustrated application: [Section 5.4, External Component Value Choice](#)).

5.4 External Component Value Choice

The full-scale output voltage V_{OUTMAX} is regulated by the reference amplifier, and is set by an internal resistor R_{SET} . I_{OUTMAX} can be expressed as:

$$I_{OUTMAX} = I_{REF} / 8 * (63 + 15/16)$$

Where:

$$V_{REF} = 0.5V$$

$$I_{REF} = V_{REF}/R_{SET}$$

The output current I_{OUT} appearing at DAC output is a function of both the input code and I_{OUTMAX} and can be expressed as:

$$I_{OUT} = (DAC_CODE/1023) * I_{OUTMAX}$$

Where:

$$DAC_CODE = 0 \text{ to } 1023 \text{ is the DAC input code in decimal.}$$

The output voltage is:

$$V_{OUT} = I_{OUT} * N * R_{CABLE}$$

Where:

$$(N = \text{amplifier gain} = 21)$$

$$R_{CABLE} = 75 \Omega \text{ (cable typical impedance)}$$

The TV-out buffer requires a per channel external resistors: $R_{OUT1/2}$. The equation below can be used to select different resistor values (if necessary):

$$R_{OUT} = (N+1) R_{CABLE} = 1650 \Omega$$

Recommended parameter values are:

Table 5-7. Video DAC – Recommended External Components Values

	Recommended Value	UNIT
C_{BG}	100	nF
$R_{OUT1/2}$	1650	Ω

In order to limit the reference noise bandwidth and to suppress transients on V_{REF} , it is necessary to connect a large decoupling capacitor (C_{BG}) between the tv_vref and vssa_dac pins.

6 TIMING REQUIREMENTS AND SWITCHING CHARACTERISTICS

6.1 Timing Test Conditions

All timing requirements and switching characteristics are valid over the recommended operating conditions of [Table 3-3](#), unless otherwise specified.

6.2 Interface Clock Specifications

6.2.1 Interface Clock Terminology

The Interface clock is used at the system level to sequence the data and/or control transfers accordingly with the interface protocol.

6.2.2 Interface Clock Frequency

The two interface clock characteristics are:

- The maximum clock frequency
- The maximum operating frequency

The interface clock frequency documented in this document is the maximum clock frequency, which corresponds to the maximum frequency programmable on this output clock. This frequency defines the maximum limit supported by the OMAP3515/03 IC and doesn't take into account any system consideration (PCB, peripherals).

The system designer will have to consider these system considerations and OMAP3515/03 IC timings characteristics as well, to define properly the maximum operating frequency, which corresponds to the maximum frequency supported to transfer the data on this interface.

6.2.3 Clock Jitter Specifications

Jitter is a phase noise, which may alter different characteristics of a clock signal. The jitter specified in this document is the time difference between the typical cycle period and the actual cycle period affected by noise sources on the clock. The cycle (or period) jitter terminology identifies this type of jitter.

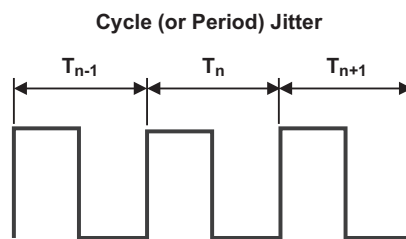

$$\text{Max. Cycle Jitter} = \text{Max} (T_i)$$

$$\text{Min. Cycle Jitter} = \text{Min} (T_i)$$

$$\text{Jitter Standard Deviation (or rms Jitter)} = \text{Standard Deviation} (T_i)$$

030-020

Figure 6-1. Cycle (or Period) Jitter

6.2.4 Clock Duty Cycle Error

The duty cycle error is the ratio between either the high-level pulse duration or the low-level pulse duration and the cycle time of a clock signal.

6.3 Timing Parameters

The timing parameter symbols used in the timing requirement and switching characteristic tables are created in accordance with JEDEC Standard 100. To shorten the symbols, some pin names and other related terminologies have been abbreviated as follows:

Table 6-1. Timing Parameters

LOWERCASE SUBSCRIPTS	
Symbols	Parameter
c	Cycle time (period)
d	Delay time
dis	Disable time
en	Enable time
h	Hold time
su	Setup time
START	Start bit
t	Transition time
v	Valid time
w	Pulse duration (width)
X	Unknown, changing, or don't care level
H	High
L	Low
V	Valid
IV	Invalid
AE	Active Edge
FE	First Edge
LE	Last Edge
Z	High impedance

PRODUCT PREVIEW

6.4 External Memory Interfaces

The OMAP3515/03 processor includes the following external memory interfaces:

- General-purpose memory controller (GPMC)
- SDRAM controller (SDRC)

6.4.1 General-Purpose Memory Controller (GPMC)

The GPMC is the OMAP3515/03 unified memory controller used to interface external memory devices such as:

- Asynchronous SRAM-like memories and ASIC devices
- Asynchronous page mode and synchronous burst NOR flash
- NAND flash

6.4.1.1 GPMC/NOR Flash Interface Synchronous Timing

Table 6-3 and Table 6-4 assume testing over the recommended operating conditions (see Figure 6-2 through Figure 6-5) and electrical characteristic conditions.

Table 6-2. GPMC/NOR Flash Synchronous Mode Timing Conditions

TIMING CONDITION PARAMETER		VALUE	UNIT
Input Conditions			
t_R	Input signal rise time	1.8	ns
t_F	Input signal fall time	1.8	ns
Output Conditions			
C_{LOAD}	Output load capacitance	15.94	pF

Table 6-3. GPMC/NOR Flash Interface Timing Requirements – Synchronous Mode

NO.	PARAMETER		1.15 V		1.0 V		0.9 V		UNIT
			MIN	MAX	MIN	MAX	MIN	MAX	
F12	$t_{su(DV-CLKH)}$	Setup time, read gpmc_d[15:0] valid before gpmc_clk high	1.9		1.9		3.2		ns
F13	$t_h(CLKH-DV)$	Hold time, read gpmc_d[15:0] valid after gpmc_clk high	2.5		2.5		2.5		ns
F21	$t_{su(WAITV-CLKH)}$	Setup time, gpmc_waitx ⁽¹⁾ valid before gpmc_clk high	1.9		1.9		3.2		ns
F22	$t_h(CLKH-WAITV)$	Hold Time, gpmc_waitx ⁽¹⁾ valid after gpmc_clk high	2.5		2.5		2.5		ns

(1) Wait monitoring support is limited to a WaitMonitoringTime value > 0. For a full description of wait monitoring feature, see the *OMAP35xx Technical Reference Manual* (literature number).

Table 6-4. GPMC/NOR Flash Interface Switching Characteristics – Synchronous Mode

NO.	PARAMETER		1.15 V		1.0 V		0.9 V		UNIT
			MIN	MAX	MIN	MAX	MIN	MAX	
F0	$t_c(CLK)$	Cycle time ⁽¹⁵⁾ , output clock gpmc_clk period	10		12.05		25		ns
F1	$t_w(CLKH)$	Typical pulse duration, output clock gpmc_clk high	0.5 P ⁽¹²⁾	0.5 P ⁽¹²⁾	0.5 P ⁽¹²⁾	0.5 P ⁽¹²⁾	0.5 P ⁽¹²⁾	0.5 P ⁽¹²⁾	ns
F1	$t_w(CLKL)$	Typical pulse duration, output clock gpmc_clk low	0.5 P ⁽¹²⁾	0.5 P ⁽¹²⁾	0.5 P ⁽¹²⁾	0.5 P ⁽¹²⁾	0.5 P ⁽¹²⁾	0.5 P ⁽¹²⁾	ns
	$t_{dc}(CLK)$	Duty cycle error, output clk gpmc_clk	–500	500	–602	602	–1250	1250	ps

Table 6-4. GPMC/NOR Flash Interface Switching Characteristics – Synchronous Mode (continued)

NO.	PARAMETER		1.15 V		1.0 V		0.9 V		UNIT
			MIN	MAX	MIN	MAX	MIN	MAX	
	$t_{j(\text{CLK})}$	Jitter standard deviation ⁽¹⁶⁾ , output clock gpmc_clk		33.3		33.3		33.3	ps
	$t_{R(\text{CLK})}$	Rise time, output clock gpmc_clk		1.6		2		2	ns
	$t_{F(\text{CLK})}$	Fall time, output clock gpmc_clk		1.6		2		2	ns
	$t_{R(\text{DO})}$	Rise time, output data		2		2		2	ns
	$t_{F(\text{DO})}$	Fall time, output data		2		2		2	ns
F2	$t_{d(\text{CLKH-nCSV})}$	Delay time, gpmc_clk rising edge to gpmc_ncsx ⁽¹¹⁾ transition	F ⁽⁶⁾ – 1.9	F ⁽⁶⁾ + 3.3	F ⁽⁶⁾ – 1.8	F ⁽⁶⁾ + 4.1	F ⁽⁶⁾ – 2.6	F ⁽⁶⁾ + 4.9	ns
F3	$t_{d(\text{CLKH-nCSIV})}$	Delay time, gpmc_clk rising edge to gpmc_ncsx ⁽¹¹⁾ invalid	E ⁽⁵⁾ – 1.9	E ⁽⁵⁾ + 3.3	E ⁽⁵⁾ – 1.8	E ⁽⁵⁾ + 4.1	E ⁽⁵⁾ – 2.6	E ⁽⁵⁾ + 4.9	ns
F4	$t_{d(\text{ADDV-CLK})}$	Delay time, address bus valid to gpmc_clk first edge	B ⁽²⁾ – 4.1	B ⁽²⁾ + 2.1	B ⁽²⁾ – 4.1	B ⁽²⁾ + 2.1	B ⁽²⁾ – 4.9	B ⁽²⁾ + 2.6	ns
F5	$t_{d(\text{CLKH-ADDIV})}$	Delay time, gpmc_clk rising edge to gpmc_a[16:1] invalid	–2.1		–2.1		–2.6		ns
F6	$t_{d(\text{nBEV-CLK})}$	Delay time, gpmc_nbe0_cle, gpmc_nbe1 valid to gpmc_clk first edge	B ⁽²⁾ – 1.1	B ⁽²⁾ + 2.1	B ⁽²⁾ – 0.9	B ⁽²⁾ + 1.9	B ⁽²⁾ – 2.6	B ⁽²⁾ + 2.6	ns
F7	$t_{d(\text{CLKH-nBEIV})}$	Delay time, gpmc_clk rising edge to gpmc_nbe0_cle, gpmc_nbe1 invalid	D ⁽⁴⁾ – 2.1	D ⁽⁴⁾ + 1.1	D ⁽⁴⁾ – 1.9	D ⁽⁴⁾ + 0.9	D ⁽⁴⁾ – 2.6	D ⁽⁴⁾ + 2.6	ns
F8	$t_{d(\text{CLKH-nADV})}$	Delay time, gpmc_clk rising edge to gpmc_nadv_ale transition	G ⁽⁷⁾ – 1.9	G ⁽⁷⁾ + 4.1	G ⁽⁷⁾ – 2.1	G ⁽⁷⁾ + 4.1	G ⁽⁷⁾ – 2.6	G ⁽⁷⁾ + 4.9	ns
F9	$t_{d(\text{CLKH-nADVIV})}$	Delay time, gpmc_clk rising edge to gpmc_nadv_ale invalid	D ⁽⁴⁾ – 1.9	D ⁽⁴⁾ + 4.1	D ⁽⁴⁾ – 2.1	D ⁽⁴⁾ + 4.1	D ⁽⁴⁾ – 2.6	D ⁽⁴⁾ + 4.9	ns
F10	$t_{d(\text{CLKH-nOE})}$	Delay time, gpmc_clk rising edge to gpmc_noe transition	H ⁽⁸⁾ – 2.1	H ⁽⁸⁾ + 2.1	H ⁽⁸⁾ – 2.1	H ⁽⁸⁾ + 2.1	H ⁽⁸⁾ – 2.6	H ⁽⁸⁾ + 4.9	ns
F11	$t_{d(\text{CLKH-nOEIV})}$	Delay time, gpcm rising edge to gpmc_noe invalid	E ⁽⁵⁾ – 2.1	E ⁽⁵⁾ + 2.1	E ⁽⁵⁾ – 2.1	E ⁽⁵⁾ + 2.1	E ⁽⁵⁾ – 2.6	E ⁽⁵⁾ + 4.9	ns
F14	$t_{d(\text{CLKH-nWE})}$	Delay time, gpmc_clk rising edge to gpmc_nwe transition	I ⁽⁹⁾ – 1.9	I ⁽⁹⁾ + 4.1	I ⁽⁹⁾ – 2.1	I ⁽⁹⁾ + 4.1	I ⁽⁹⁾ – 2.6	I ⁽⁹⁾ + 4.9	ns
F15	$t_{d(\text{CLKH-Data})}$	Delay time, gpmc_clk rising edge to data bus transition	J ⁽¹⁰⁾ – 2.1	J ⁽¹⁰⁾ + 1.1	J ⁽¹⁰⁾ – 1.9	J ⁽¹⁰⁾ + 0.9	J ⁽¹⁰⁾ – 2.6	J ⁽¹⁰⁾ + 2.6	ns
F17	$t_{d(\text{CLKH-nBE})}$	Delay time, gpmc_clk rising edge to gpmc_nbex_cle transition	J ⁽¹⁰⁾ – 2.1	J ⁽¹⁰⁾ + 1.1	J ⁽¹⁰⁾ – 1.9	J ⁽¹⁰⁾ + 0.9	J ⁽¹⁰⁾ – 2.6	J ⁽¹⁰⁾ + 2.6	ns
F18	$t_{W(\text{nCSV})}$	Pulse duration, gpmc_ncsx ⁽¹¹⁾ low	Read	A ⁽¹⁾		A ⁽¹⁾		A ⁽¹⁾	ns
			Write	A ⁽¹⁾		A ⁽¹⁾		A ⁽¹⁾	ns
F19	$t_{W(\text{nBEV})}$	Pulse duration, gpmc_nbe0_cle, gpmc_nbe1 low	Read	C ⁽³⁾		C ⁽³⁾		C ⁽³⁾	ns
			Write	C ⁽³⁾		C ⁽³⁾		C ⁽³⁾	ns
F20	$t_{W(\text{nADV})}$	Pulse duration, gpmc_nadv_ale low	Read	K ⁽¹³⁾		K ⁽¹³⁾		K ⁽¹³⁾	ns
			Write	K ⁽¹³⁾		K ⁽¹³⁾		K ⁽¹³⁾	ns

- (1) **For single read:** $A = (\text{CSRdOffTime} - \text{CSOnTime}) * (\text{TimeParaGranularity} + 1) * \text{GPMC_FCLK period}$
For burst read: $A = (\text{CSRdOffTime} - \text{CSOnTime} + (n - 1) * \text{PageBurstAccessTime}) * (\text{TimeParaGranularity} + 1) * \text{GPMC_FCLK period}$
For burst write: $A = (\text{CSWrOffTime} - \text{CSOnTime} + (n - 1) * \text{PageBurstAccessTime}) * (\text{TimeParaGranularity} + 1) * \text{GPMC_FCLK period}$
 with n being the page burst access number.
- (2) $B = \text{ClkActivationTime} * \text{GPMC_FCLK}$
- (3) **For single read:** $C = \text{RdCycleTime} * (\text{TimeParaGranularity} + 1) * \text{GPMC_FCLK}$
For burst read: $C = (\text{RdCycleTime} + (n - 1) * \text{PageBurstAccessTime}) * (\text{TimeParaGranularity} + 1) * \text{GPMC_FCLK}$
For burst write: $C = (\text{WrCycleTime} + (n - 1) * \text{PageBurstAccessTime}) * (\text{TimeParaGranularity} + 1) * \text{GPMC_FCLK}$ with n being the page burst access number.
- (4) **For single read:** $D = (\text{RdCycleTime} - \text{AccessTime}) * (\text{TimeParaGranularity} + 1) * \text{GPMC_FCLK}$
For burst read: $D = (\text{RdCycleTime} - \text{AccessTime}) * (\text{TimeParaGranularity} + 1) * \text{GPMC_FCLK}$
For burst write: $D = (\text{WrCycleTime} - \text{AccessTime}) * (\text{TimeParaGranularity} + 1) * \text{GPMC_FCLK}$
- (5) **For single read:** $E = (\text{CSRdOffTime} - \text{AccessTime}) * (\text{TimeParaGranularity} + 1) * \text{GPMC_FCLK}$
For burst read: $E = (\text{CSRdOffTime} - \text{AccessTime}) * (\text{TimeParaGranularity} + 1) * \text{GPMC_FCLK}$
For burst write: $E = (\text{CSWrOffTime} - \text{AccessTime}) * (\text{TimeParaGranularity} + 1) * \text{GPMC_FCLK}$
- (6) **For nCS falling edge (CS activated):**
- **Case GpmcFCLKDivider = 0:**
 - $F = 0.5 * \text{CSExtraDelay} * \text{GPMC_FCLK}$
 - **Case GpmcFCLKDivider = 1:**
 - $F = 0.5 * \text{CSExtraDelay} * \text{GPMC_FCLK}$ if (ClkActivationTime and CSOnTime are odd) or (ClkActivationTime and CSOnTime are even)
 - $F = (1 + 0.5 * \text{CSExtraDelay}) * \text{GPMC_FCLK}$ otherwise
 - **Case GpmcFCLKDivider = 2:**
 - $F = 0.5 * \text{CSExtraDelay} * \text{GPMC_FCLK}$ if ((CSOnTime – ClkActivationTime) is a multiple of 3)
 - $F = (1 + 0.5 * \text{CSExtraDelay}) * \text{GPMC_FCLK}$ if ((CSOnTime – ClkActivationTime – 1) is a multiple of 3)
 - $F = (2 + 0.5 * \text{CSExtraDelay}) * \text{GPMC_FCLK}$ if ((CSOnTime – ClkActivationTime – 2) is a multiple of 3)
- (7) **For ADV falling edge (ADV activated):**
- **Case GpmcFCLKDivider = 0:**
 - $G = 0.5 * \text{ADVExtraDelay} * \text{GPMC_FCLK}$
 - **Case GpmcFCLKDivider = 1:**
 - $G = 0.5 * \text{ADVExtraDelay} * \text{GPMC_FCLK}$ if (ClkActivationTime and ADVOnTime are odd) or (ClkActivationTime and ADVOnTime are even)
 - $G = (1 + 0.5 * \text{ADVExtraDelay}) * \text{GPMC_FCLK}$ otherwise
 - **Case GpmcFCLKDivider = 2:**
 - $G = 0.5 * \text{ADVExtraDelay} * \text{GPMC_FCLK}$ if ((ADVOnTime – ClkActivationTime) is a multiple of 3)
 - $G = (1 + 0.5 * \text{ADVExtraDelay}) * \text{GPMC_FCLK}$ if ((ADVOnTime – ClkActivationTime – 1) is a multiple of 3)
 - $G = (2 + 0.5 * \text{ADVExtraDelay}) * \text{GPMC_FCLK}$ if ((ADVOnTime – ClkActivationTime – 2) is a multiple of 3)
- For ADV rising edge (ADV deactivated) in Reading mode:**
- **Case GpmcFCLKDivider = 0:**
 - $G = 0.5 * \text{ADVExtraDelay} * \text{GPMC_FCLK}$
 - **Case GpmcFCLKDivider = 1:**
 - $G = 0.5 * \text{ADVExtraDelay} * \text{GPMC_FCLK}$ if (ClkActivationTime and ADVRdOffTime are odd) or (ClkActivationTime and ADVRdOffTime are even)
 - $G = (1 + 0.5 * \text{ADVExtraDelay}) * \text{GPMC_FCLK}$ otherwise
 - **Case GpmcFCLKDivider = 2:**
 - $G = 0.5 * \text{ADVExtraDelay} * \text{GPMC_FCLK}$ if ((ADVRdOffTime – ClkActivationTime) is a multiple of 3)
 - $G = (1 + 0.5 * \text{ADVExtraDelay}) * \text{GPMC_FCLK}$ if ((ADVRdOffTime – ClkActivationTime – 1) is a multiple of 3)
 - $G = (2 + 0.5 * \text{ADVExtraDelay}) * \text{GPMC_FCLK}$ if ((ADVRdOffTime – ClkActivationTime – 2) is a multiple of 3)
- For ADV rising edge (ADV deactivated) in Writing mode:**
- **Case GpmcFCLKDivider = 0:**
 - $G = 0.5 * \text{ADVExtraDelay} * \text{GPMC_FCLK}$
 - **Case GpmcFCLKDivider = 1:**
 - $G = 0.5 * \text{ADVExtraDelay} * \text{GPMC_FCLK}$ if (ClkActivationTime and ADVWrOffTime are odd) or (ClkActivationTime and ADVWrOffTime are even)
 - $G = (1 + 0.5 * \text{ADVExtraDelay}) * \text{GPMC_FCLK}$ otherwise
 - **Case GpmcFCLKDivider = 2:**
 - $G = 0.5 * \text{ADVExtraDelay} * \text{GPMC_FCLK}$ if ((ADVWrOffTime – ClkActivationTime) is a multiple of 3)
 - $G = (1 + 0.5 * \text{ADVExtraDelay}) * \text{GPMC_FCLK}$ if ((ADVWrOffTime – ClkActivationTime – 1) is a multiple of 3)
 - $G = (2 + 0.5 * \text{ADVExtraDelay}) * \text{GPMC_FCLK}$ if ((ADVWrOffTime – ClkActivationTime – 2) is a multiple of 3)
- (8) **For OE falling edge (OE activated):**
- **Case GpmcFCLKDivider = 0:**
 - $H = 0.5 * \text{OEEExtraDelay} * \text{GPMC_FCLK}$
 - **Case GpmcFCLKDivider = 1:**
 - $H = 0.5 * \text{OEEExtraDelay} * \text{GPMC_FCLK}$ if (ClkActivationTime and OEOnTime are odd) or (ClkActivationTime and OEOnTime are even)
 - $H = (1 + 0.5 * \text{OEEExtraDelay}) * \text{GPMC_FCLK}$ otherwise
 - **Case GpmcFCLKDivider = 2:**

- $H = 0.5 * OEExtraDelay * GPMC_FCLK$ if $((OEOnTime - ClkActivationTime)$ is a multiple of 3)
- $H = (1 + 0.5 * OEExtraDelay) * GPMC_FCLK$ if $((OEOnTime - ClkActivationTime - 1)$ is a multiple of 3)
- $H = (2 + 0.5 * OEExtraDelay) * GPMC_FCLK$ if $((OEOnTime - ClkActivationTime - 2)$ is a multiple of 3)

For OE rising edge (OE deactivated):

- **GpmcFCLKDivider = 0:**
 - $H = 0.5 * OEExtraDelay * GPMC_FCLK$
- **Case GpmcFCLKDivider = 1:**
 - $H = 0.5 * OEExtraDelay * GPMC_FC$ if $(ClkActivationTime$ and $OEOffTime$ are odd) or $(ClkActivationTime$ and $OEOffTime$ are even)
 - $H = (1 + 0.5 * OEExtraDelay) * GPMC_FCLK$ otherwise
- **Case GpmcFCLKDivider = 2:**
 - $H = 0.5 * OEExtraDelay * GPMC_FCLK$ if $((OEOffTime - ClkActivationTime)$ is a multiple of 3)
 - $H = (1 + 0.5 * OEExtraDelay) * GPMC_FCLK$ if $((OEOffTime - ClkActivationTime - 1)$ is a multiple of 3)
 - $H = (2 + 0.5 * OEExtraDelay) * GPMC_FCLK$ if $((OEOffTime - ClkActivationTime - 2)$ is a multiple of 3)

(9) For WE falling edge (WE activated):

- **Case GpmcFCLKDivider = 0:**
 - $I = 0.5 * WEEExtraDelay * GPMC_FCLK$
- **Case GpmcFCLKDivider = 1:**
 - $I = 0.5 * WEEExtraDelay * GPMC_FCLK$ if $(ClkActivationTime$ and $WEOnTime$ are odd) or $(ClkActivationTime$ and $WEOnTime$ are even)
 - $I = (1 + 0.5 * WEEExtraDelay) * GPMC_FCLK$ otherwise
- **Case GpmcFCLKDivider = 2:**
 - $I = 0.5 * WEEExtraDelay * GPMC_FCLK$ if $((WEOnTime - ClkActivationTime)$ is a multiple of 3)
 - $I = (1 + 0.5 * WEEExtraDelay) * GPMC_FCLK$ if $((WEOnTime - ClkActivationTime - 1)$ is a multiple of 3)
 - $I = (2 + 0.5 * WEEExtraDelay) * GPMC_FCLK$ if $((WEOnTime - ClkActivationTime - 2)$ is a multiple of 3)

For WE rising edge (WE deactivated):

- **Case GpmcFCLKDivider = 0:**
 - $I = 0.5 * WEEExtraDelay * GPMC_FCLK$
- **Case GpmcFCLKDivider = 1:**
 - $I = 0.5 * WEEExtraDelay * GPMC_FCLK$ if $(ClkActivationTime$ and $WEOffTime$ are odd) or $(ClkActivationTime$ and $WEOffTime$ are even)
 - $I = (1 + 0.5 * WEEExtraDelay) * GPMC_FCLK$ otherwise
- **Case GpmcFCLKDivider = 2:**
 - $I = 0.5 * WEEExtraDelay * GPMC_FCLK$ if $((WEOffTime - ClkActivationTime)$ is a multiple of 3)
 - $I = (1 + 0.5 * WEEExtraDelay) * GPMC_FCLK$ if $((WEOffTime - ClkActivationTime - 1)$ is a multiple of 3)
 - $I = (2 + 0.5 * WEEExtraDelay) * GPMC_FCLK$ if $((WEOffTime - ClkActivationTime - 2)$ is a multiple of 3)

(10) $J = GPMC_FCLK$ period

(11) In $gpmc_ncsx$, x is equal to 0, 1, 2, 3, 4, 5, 6, or 7. In $gpmc_waitx$, x is equal to 0, 1, 2, or 3.

(12) $P = gpmc_clk$ period

(13) **For read:** $K = (ADVrdOffTime - ADVOnTime) * (TimeParaGranularity + 1) * GPMC_FCLK$
For write: $K = (ADVWrOffTime - ADVOnTime) * (TimeParaGranularity + 1) * GPMC_FCLK$

(14) $GPMC_FCLK$ is General-Purpose Memory Controller internal functional clock.

(15) Related to the $gpmc_clk$ output clock maximum and minimum frequencies programmable in the I/F module by setting the $GPMC_CONFIG1_CSx$ configuration register bit field $GpmcFCLKDivider$.

(16) The jitter probability density can be approximated by a Gaussian function.

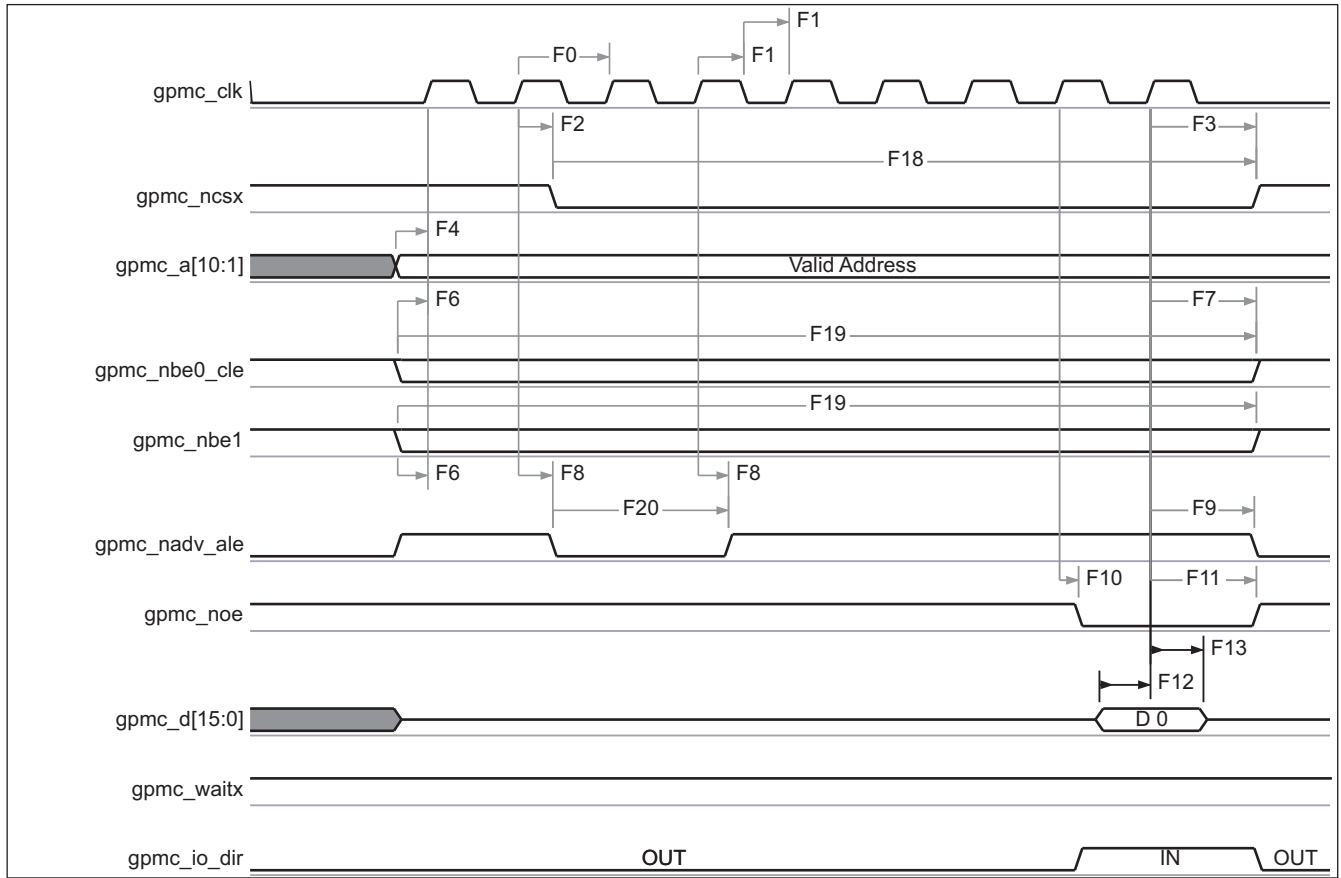

030-021

In gpmc_ncsx, x is equal to 0, 1, 2, 3, 4, 5, 6, or 7. In gpmc_waitx, x is equal to 0, 1, 2, or 3.

Figure 6-2. GPMC/NOR Flash – Synchronous Single Read – (GpmcFCLKDivider = 0)

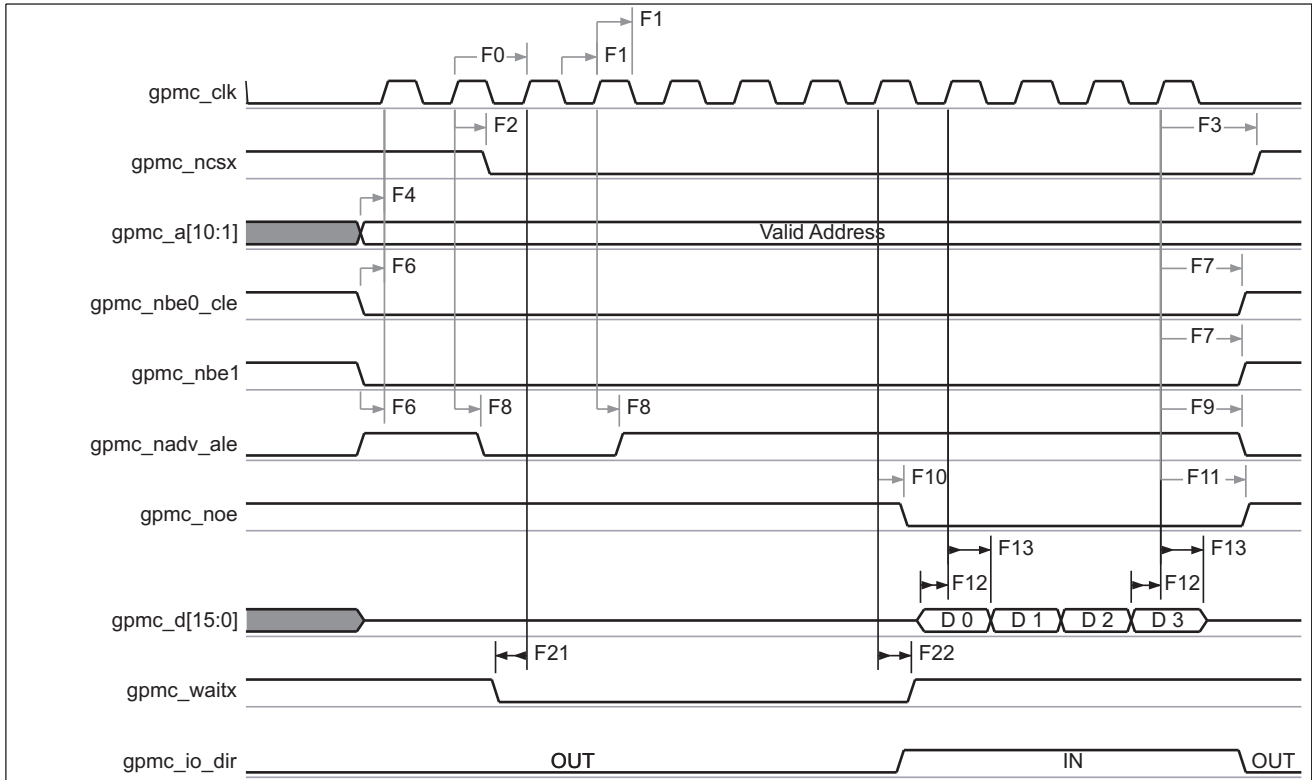

030-022

In gpmc_ncsx, x is equal to 0, 1, 2, 3, 4, 5, 6, or 7. In gpmc_waitx, x is equal to 0, 1, 2, or 3.

Figure 6-3. GPMC/NOR Flash – Synchronous Burst Read – 4x16-bit (GpmcFCLKDivider = 0)

PRODUCT PREVIEW

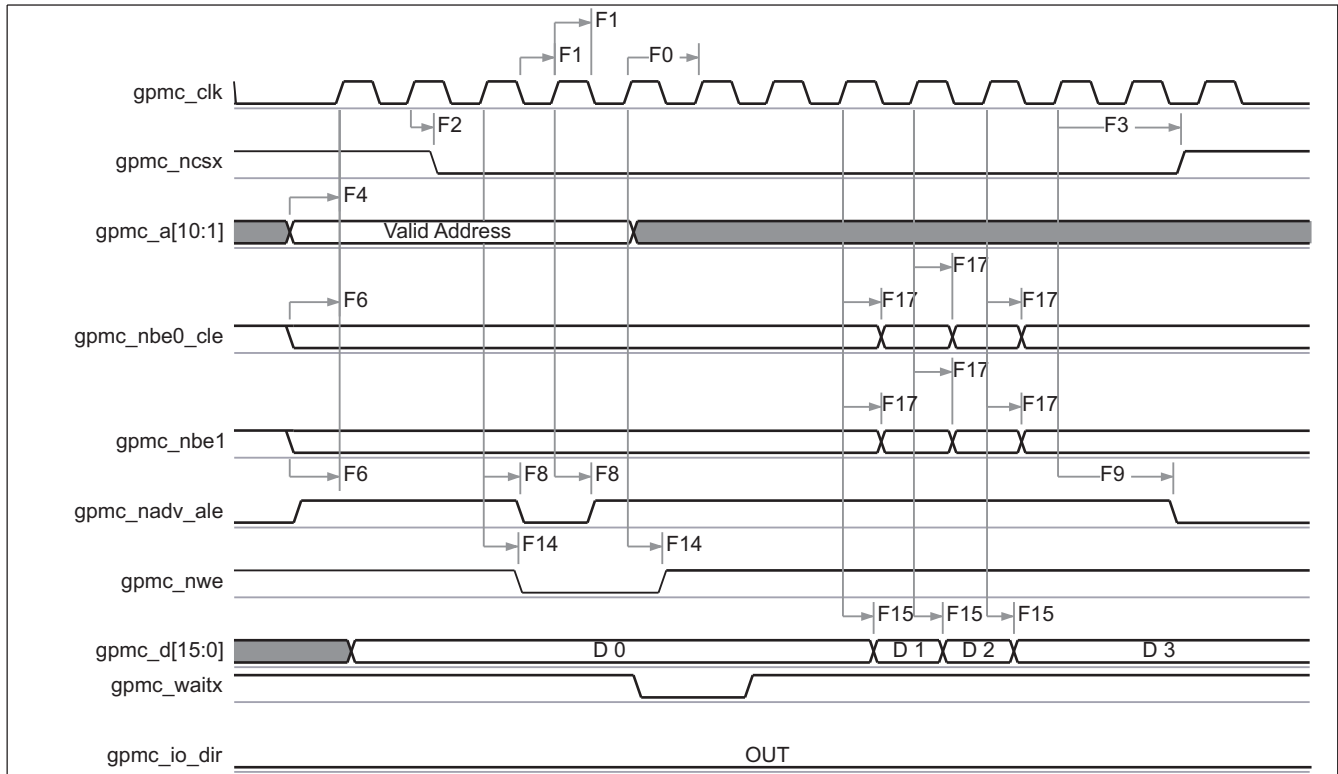

030-023

In gpmc_ncsx, x is equal to 0, 1, 2, 3, 4, 5, 6, or 7. In gpmc_waitx, x is equal to 0, 1, 2, or 3.

Figure 6-4. GPMC/NOR Flash – Synchronous Burst Write – (GpmcFCLKDivider = 0)

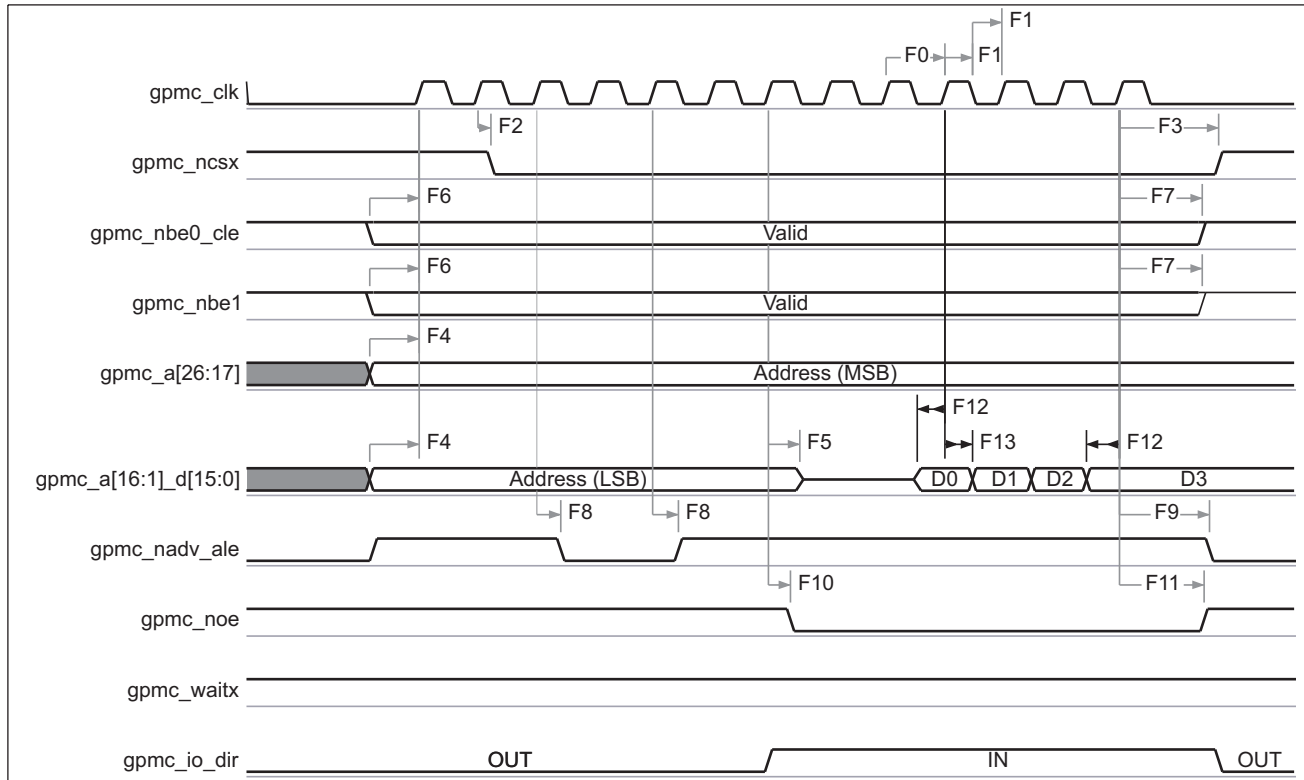

030-024

In gpmc_ncsx, x is equal to 0, 1, 2, 3, 4, 5, 6, or 7. In gpmc_waitx, x is equal to 0, 1, 2, or 3.

Figure 6-5. GPMC/Multiplexed NOR Flash – Synchronous Burst Read

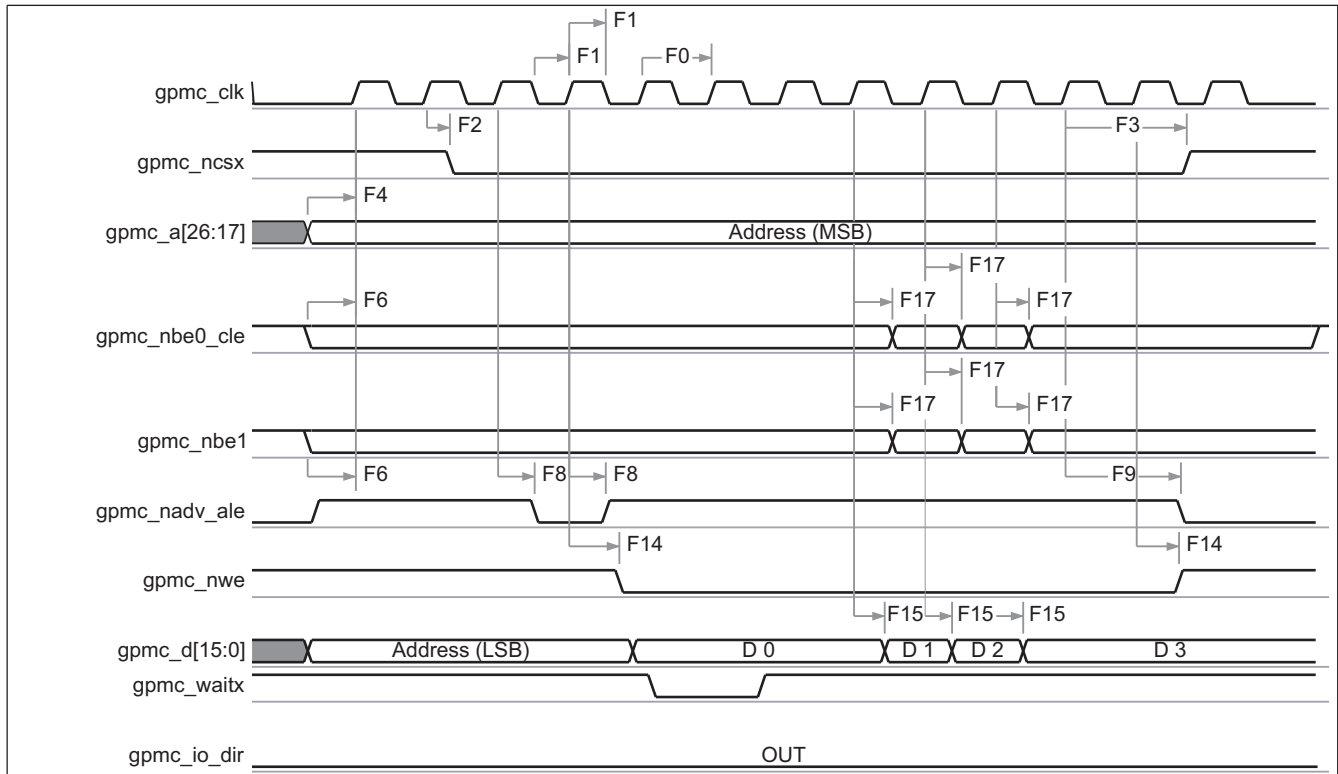

030-025

In gpmc_ncsx, x is equal to 0, 1, 2, 3, 4, 5, 6, or 7. In gpmc_waitx, x is equal to 0, 1, 2, or 3.

Figure 6-6. GPMC/Multiplexed NOR Flash – Synchronous Burst Write

6.4.1.2 GPMC/NOR Flash Interface Asynchronous Timing

Table 6-7 and Table 6-8 assume testing over the recommended operating conditions (see Figure 6-7 through Figure 6-12) and electrical characteristic conditions.

Table 6-5. GPMC/NOR Flash Asynchronous Mode Timing Conditions

TIMING CONDITION PARAMETER		VALUE	UNIT
Input Conditions			
t_R	Input signal rise time	1.8	ns
t_F	Input signal fall time	1.8	ns
Output Conditions			
C_{LOAD}	Output load capacitance	15.94	pF

Table 6-6. GPMC/NOR Flash Interface Asynchronous Timing – Internal Parameters⁽¹⁾⁽²⁾

NO.	PARAMETER	1.15 V		1.0 V		0.9 V		UNIT
		MIN	MAX	MIN	MAX	MIN	MAX	
F11	Maximum output data generation delay from internal functional clock		6.5		9.1		13.7	ns
F12	Maximum input data capture delay by internal functional clock		4		5.6		8.1	ns
F13	Maximum device select generation delay from internal functional clock		6.5		9.1		13.7	ns
F14	Maximum address generation delay from internal functional clock		6.5		9.1		13.7	ns

Table 6-6. GPMC/NOR Flash Interface Asynchronous Timing – Internal Parameters⁽¹⁾⁽²⁾ (continued)

NO.	PARAMETER	1.15 V		1.0 V		0.9 V		UNIT
		MIN	MAX	MIN	MAX	MIN	MAX	
FI5	Maximum address valid generation delay from internal functional clock		6.5		9.1		13.7	ns
FI6	Maximum byte enable generation delay from internal functional clock		6.5		9.1		13.7	ns
FI7	Maximum output enable generation delay from internal functional clock		6.5		9.1		13.7	ns
FI8	Maximum write enable generation delay from internal functional clock		6.5		9.1		13.7	ns
FI9	Maximum functional clock skew		100		170		200	ps

- (1) The internal parameters table must be used to calculate Data Access Time stored in the corresponding CS register bit field. Internal parameters are referred to the GPMC functional internal clock which is not provided externally.
(2) Internal parameters are referred to the GPMC functional internal clock which is not provided externally.

Table 6-7. GPMC/NOR Flash Interface Timing Requirements – Asynchronous Mode

NO.	PARAMETER		1.15 V		1.0 V		0.9 V		UNIT
			MIN	MAX	MIN	MAX	MIN	MAX	
FA5 ⁽¹⁾	$t_{acc(DAT)}$	Data maximum access time		H ⁽⁵⁾		H ⁽⁵⁾		H ⁽⁵⁾	GPMC_FCLK cycles
FA20 ⁽³⁾	$t_{acc1-pgmode(DAT)}$	Page mode successive data maximum access time		P ⁽⁴⁾		P ⁽⁴⁾		P ⁽⁴⁾	GPMC_FCLK cycles
FA21 ⁽²⁾	$t_{acc2-pgmode(DAT)}$	Page mode first data maximum access time		H ⁽⁵⁾		H ⁽⁵⁾		H ⁽⁵⁾	GPMC_FCLK cycles

- (1) The FA5 parameter illustrates the amount of time required to internally sample input Data. It is expressed in number of GPMC functional clock cycles. From start of read cycle and after FA5 functional clock cycles, input Data is internally sampled by active functional clock edge. FA5 value must be stored inside the AccessTime register bit field.
(2) The FA21 parameter illustrates amount of time required to internally sample first input Page Data. It is expressed in number of GPMC functional clock cycles. From start of read cycle and after FA21 functional clock cycles, First input Page Data is internally sampled by active functional clock edge. FA21 value must be stored inside the AccessTime register bit field.
(3) The FA20 parameter illustrates amount of time required to internally sample successive input Page Data. It is expressed in number of GPMC functional clock cycles. After each access to input Page Data, next input Page Data is internally sampled by active functional clock edge after FA20 functional clock cycles. The FA20 value must be stored in the PageBurstAccessTime register bit field.
(4) $P = PageBurstAccessTime * (TimeParaGranularity + 1)$
(5) $H = AccessTime * (TimeParaGranularity + 1)$

Table 6-8. GPMC/NOR Flash Interface Switching Characteristics – Asynchronous Mode

NO.	PARAMETER		1.15 V		1.0 V		0.9 V		UNIT
			MIN	MAX	MIN	MAX	MIN	MAX	
	$t_{R(DO)}$	Rise time, output data		2.0		2.0		2.0	ns
	$t_{F(DO)}$	Fall time, output data		2.0		2.0		2.0	ns
FA0	$t_{W(nBEV)}$	Read	N ⁽¹²⁾		N ⁽¹²⁾		N ⁽¹²⁾		ns
		Write	N ⁽¹²⁾		N ⁽¹²⁾		N ⁽¹²⁾		ns
FA1	$t_{W(nCSV)}$	Read	A ⁽¹⁾		A ⁽¹⁾		A ⁽¹⁾		ns
		Write	A ⁽¹⁾		A ⁽¹⁾		A ⁽¹⁾		ns
FA3	$t_{d(nCSV-nADVIV)}$	Read	B ⁽²⁾ – 0.2	B ⁽²⁾ + 2.0	B ⁽²⁾ – 0.2	B ⁽²⁾ + 2.6	B ⁽²⁾ – 0.2	B ⁽²⁾ + 3.7	ns
		Write	B ⁽²⁾ – 0.2	B ⁽²⁾ + 2.0	B ⁽²⁾ – 0.2	B ⁽²⁾ + 2.6	B ⁽²⁾ – 0.2	B ⁽²⁾ + 3.7	ns

Table 6-8. GPMC/NOR Flash Interface Switching Characteristics – Asynchronous Mode (continued)

NO.	PARAMETER		1.15 V		1.0 V		0.9 V		UNIT
			MIN	MAX	MIN	MAX	MIN	MAX	
FA4	$t_{d(nCSV-nOEIV)}$	Delay time, gpmc_ncsx ⁽¹³⁾ valid to gpmc_noe invalid (Single read)	C ⁽³⁾ – 0.2	C ⁽³⁾ + 2.0	C ⁽³⁾ – 0.2	C ⁽³⁾ + 2.6	C ⁽³⁾ – 0.2	C ⁽³⁾ + 3.7	ns
FA9	$t_{d(AV-nCSV)}$	Delay time, address bus valid to gpmc_ncsx ⁽¹³⁾ valid	J ⁽⁹⁾ – 0.2	J ⁽⁹⁾ + 2.0	J ⁽⁹⁾ – 0.2	J ⁽⁹⁾ + 2.6	J ⁽⁹⁾ – 0.2	J ⁽⁹⁾ + 3.7	ns
FA10	$t_{d(nBEV-nCSV)}$	Delay time, gpmc_nbe0_cle, gpmc_nbe1 valid to gpmc_ncsx ⁽¹³⁾ valid	J ⁽⁹⁾ – 0.2	J ⁽⁹⁾ + 2.0	J ⁽⁹⁾ – 0.2	J ⁽⁹⁾ + 2.6	J ⁽⁹⁾ – 0.2	J ⁽⁹⁾ + 3.7	ns
FA12	$t_{d(nCSV-nADV)}$	Delay time, gpmc_ncsx ⁽¹³⁾ valid to gpmc_nadv_ale valid	K ⁽¹⁰⁾ – 0.2	K ⁽¹⁰⁾ + 2.0	K ⁽¹⁰⁾ – 0.2	K ⁽¹⁰⁾ + 2.6	K ⁽¹⁰⁾ – 0.2	K ⁽¹⁰⁾ + 3.7	ns
FA13	$t_{d(nCSV-nOEIV)}$	Delay time, gpmc_ncsx ⁽¹³⁾ valid to gpmc_noe valid	L ⁽¹¹⁾ – 0.2	L ⁽¹¹⁾ + 2.0	L ⁽¹¹⁾ – 0.2	L ⁽¹¹⁾ + 2.6	L ⁽¹¹⁾ – 0.2	L ⁽¹¹⁾ + 3.7	ns
FA16	$t_{w(AIV)}$	Address invalid duration between 2 successive R/W accesses	G ⁽⁷⁾		G ⁽⁷⁾		G ⁽⁷⁾		ns
FA18	$t_{d(nCSV-nOEIV)}$	Delay time, gpmc_ncsx ⁽¹³⁾ valid to gpmc_noe invalid (Burst read)	I ⁽⁸⁾ – 0.2	I ⁽⁸⁾ + 2.0	I ⁽⁸⁾ – 0.2	I ⁽⁸⁾ + 2.6	I ⁽⁸⁾ – 0.2	I ⁽⁸⁾ + 3.7	ns
FA20	$t_{w(AV)}$	Pulse duration, address valid – 2nd, 3rd, and 4th accesses	D ⁽⁴⁾		D ⁽⁴⁾		D ⁽⁴⁾		ns
FA25	$t_{d(nCSV-nWEV)}$	Delay time, gpmc_ncsx ⁽¹³⁾ valid to gpmc_nwe valid	E ⁽⁵⁾ – 0.2	E ⁽⁵⁾ + 2.0	E ⁽⁵⁾ – 0.2	E ⁽⁵⁾ + 2.6	E ⁽⁵⁾ – 0.2	E ⁽⁵⁾ + 3.7	ns
FA27	$t_{d(nCSV-nWEIV)}$	Delay time, gpmc_ncsx ⁽¹³⁾ valid to gpmc_nwe invalid	F ⁽⁶⁾ – 0.2	F ⁽⁶⁾ + 2.0	F ⁽⁶⁾ – 0.2	F ⁽⁶⁾ + 2.6	F ⁽⁶⁾ – 0.2	F ⁽⁶⁾ + 3.7	ns
FA28	$t_{d(nWEV-DV)}$	Delay time, gpmc_new valid to data bus valid		2.0		2.6		3.7	ns
FA29	$t_{d(DV-nCSV)}$	Delay time, data bus valid to gpmc_ncsx ⁽¹³⁾ valid	J ⁽⁹⁾ – 0.2	J ⁽⁹⁾ + 2.0	J ⁽⁹⁾ – 0.2	J ⁽⁹⁾ + 2.6	J ⁽⁹⁾ – 0.2	J ⁽⁹⁾ + 3.7	ns
FA37	$t_{d(nOEIV-AIV)}$	Delay time, gpmc_noe valid to gpmc_a[16:1]_d[15:0] address phase end		2.0		2.6		3.7	ns

- (1) **For single read:** A = (CSRdOffTime – CSONTime) * (TimeParaGranularity + 1) * GPMC_FCLK
For single write: A = (CSWrOffTime – CSONTime) * (TimeParaGranularity + 1) * GPMC_FCLK
For burst read: A = (CSRdOffTime – CSONTime + (n – 1) * PageBurstAccessTime) * (TimeParaGranularity + 1) * GPMC_FCLK
For burst write: A = (CSWrOffTime – CSONTime + (n – 1) * PageBurstAccessTime) * (TimeParaGranularity + 1) * GPMC_FCLK with n being the page burst access number
- (2) **For reading:** B = ((ADVrOffTime – CSONTime) * (TimeParaGranularity + 1) + 0.5 * (ADVExtraDelay – CSEExtraDelay)) * GPMC_FCLK
For writing: B = ((ADVrOffTime – CSONTime) * (TimeParaGranularity + 1) + 0.5 * (ADVExtraDelay – CSEExtraDelay)) * GPMC_FCLK
- (3) C = ((OEOffTime – CSONTime) * (TimeParaGranularity + 1) + 0.5 * (OEEExtraDelay – CSEExtraDelay)) * GPMC_FCLK
- (4) D = PageBurstAccessTime * (TimeParaGranularity + 1) * GPMC_FCLK
- (5) E = ((WEOffTime – CSONTime) * (TimeParaGranularity + 1) + 0.5 * (WEEExtraDelay – CSEExtraDelay)) * GPMC_FCLK
- (6) F = ((WEOffTime – CSONTime) * (TimeParaGranularity + 1) + 0.5 * (WEEExtraDelay – CSEExtraDelay)) * GPMC_FCLK
- (7) G = Cycle2CycleDelay * GPMC_FCLK
- (8) I = ((OEOffTime + (n – 1) * PageBurstAccessTime – CSONTime) * (TimeParaGranularity + 1) + 0.5 * (OEEExtraDelay – CSEExtraDelay)) * GPMC_FCLK
- (9) J = (CSONTime * (TimeParaGranularity + 1) + 0.5 * CSEExtraDelay) * GPMC_FCLK

- (10) $K = ((ADV_{OnTime} - CS_{OnTime}) * (TimeParaGranularity + 1) + 0.5 * (ADV_{ExtraDelay} - CS_{ExtraDelay})) * GPMC_FCLK$
- (11) $L = ((OE_{OnTime} - CS_{OnTime}) * (TimeParaGranularity + 1) + 0.5 * (OE_{ExtraDelay} - CS_{ExtraDelay})) * GPMC_FCLK$
- (12) **For single read:** $N = RdCycleTime * (TimeParaGranularity + 1) * GPMC_FCLK$
For single write: $N = WrCycleTime * (TimeParaGranularity + 1) * GPMC_FCLK$
For burst read: $N = (RdCycleTime + (n - 1) * PageBurstAccessTime) * (TimeParaGranularity + 1) * GPMC_FCLK$
For burst write: $N = (WrCycleTime + (n - 1) * PageBurstAccessTime) * (TimeParaGranularity + 1) * GPMC_FCLK$
- (13) In `gpmc_ncsx`, x is equal to 0, 1, 2, 3, 4, 5, 6, or 7.

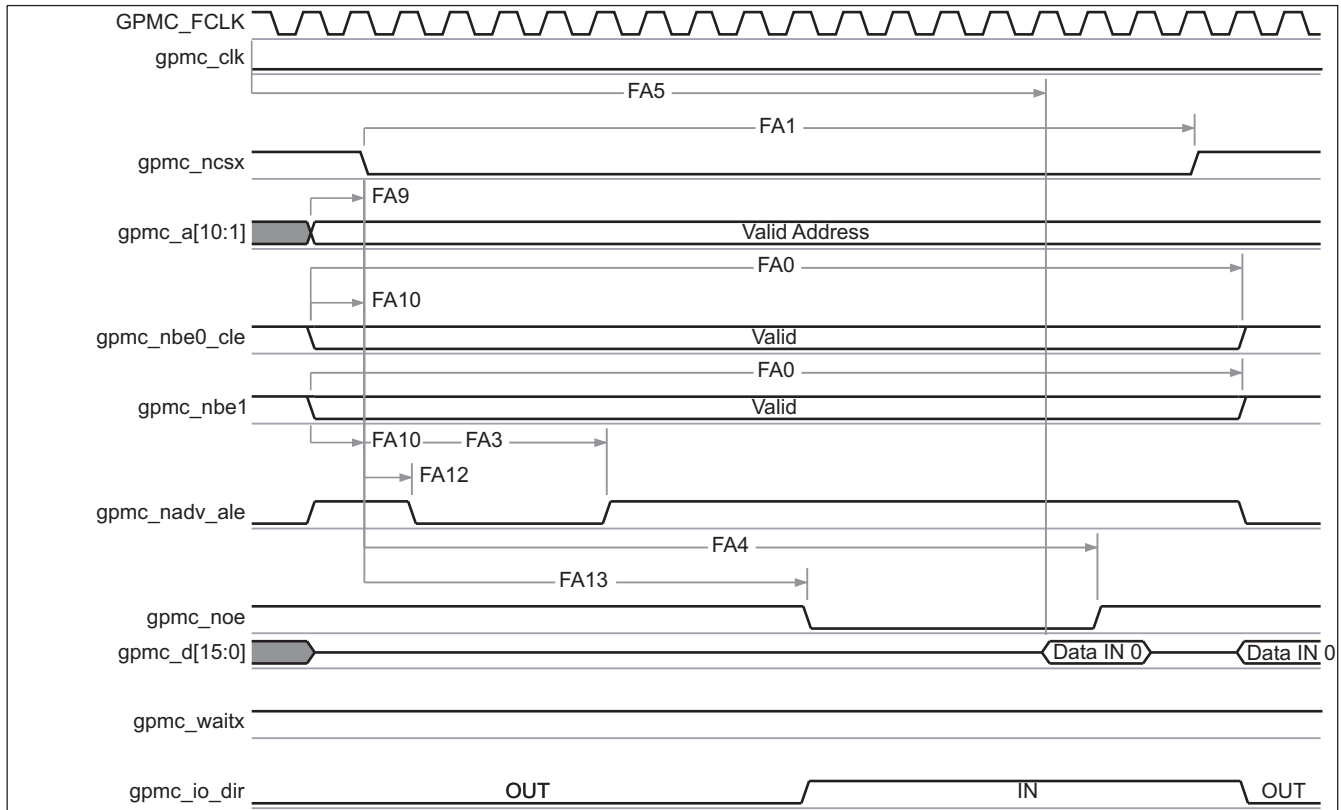

030-026

Figure 6-7. GPMC/NOR Flash – Asynchronous Read – Single Word Timing⁽¹⁾⁽²⁾⁽³⁾

- (1) In `gpmc_ncsx`, x is equal to 0, 1, 2, 3, 4, 5, 6, or 7. In `gpmc_waitx`, x is equal to 0, 1, 2, or 3.
- (2) FA5 parameter illustrates amount of time required to internally sample input data. It is expressed in number of GPMC functional clock cycles. From start of read cycle and after FA5 functional clock cycles, input data is internally sampled by active functional clock edge. FA5 value must be stored inside `AccessTime` register bit field.
- (3) `GPMC_FCLK` is an internal clock (GPMC functional clock) not provided externally.

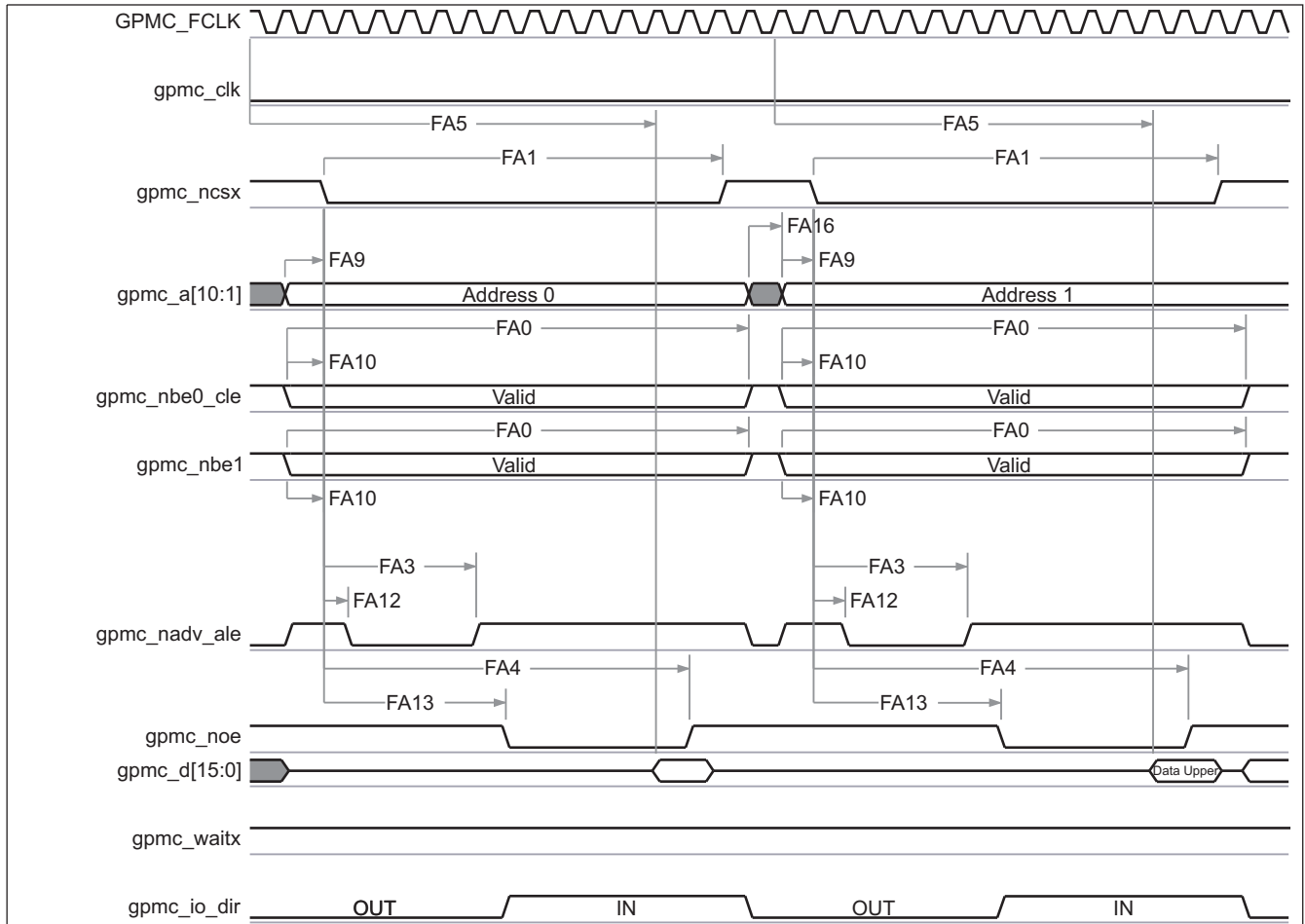

030-027

Figure 6-8. GPMC/NOR Flash – Asynchronous Read – 32-bit Timing⁽¹⁾⁽²⁾⁽³⁾

- (1) In gpmc_ncsx, x is equal to 0, 1, 2, 3, 4, 5, 6, or 7. In gpmc_waitx, x is equal to 0, 1, 2, or 3.
- (2) FA5 parameter illustrates amount of time required to internally sample input data. It is expressed in number of GPMC functional clock cycles. From start of read cycle and after FA5 functional clock cycles, input data is internally sampled by active functional clock edge. FA5 value must be stored inside AccessTime register bit field.
- (3) GPMC_FCLK is an internal clock (GPMC functional clock) not provided externally.

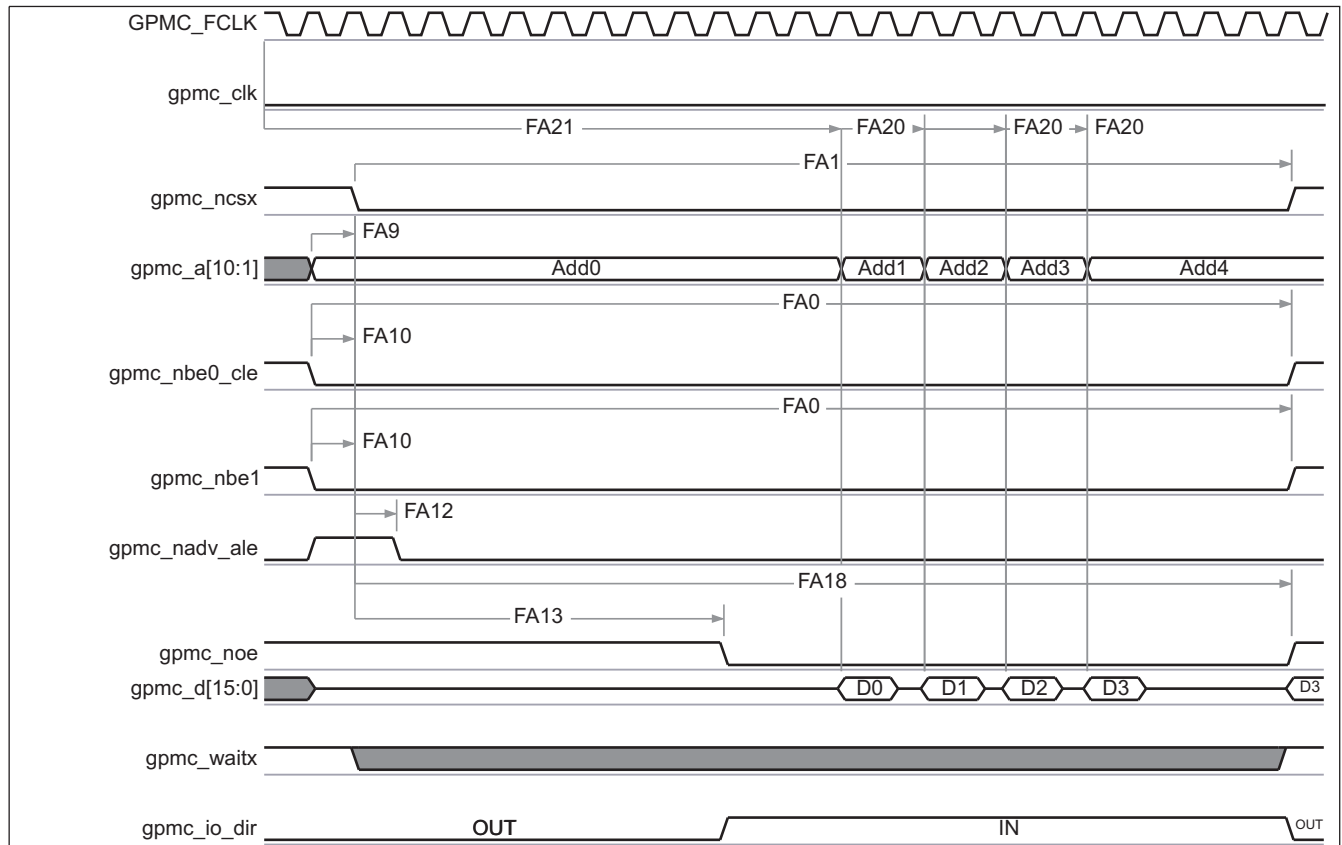

030-028

Figure 6-9. GPMC/NOR Flash – Asynchronous Read – Page Mode 4x16-bit Timing⁽¹⁾⁽²⁾⁽³⁾⁽⁴⁾

- (1) In gpmc_ncsx, x is equal to 0, 1, 2, 3, 4, 5, 6, or 7. In gpmc_waitx, x is equal to 0, 1, 2, or 3.
- (2) FA21 parameter illustrates amount of time required to internally sample first input page data. It is expressed in number of GPMC functional clock cycles. From start of read cycle and after FA21 functional clock cycles, first input page data is internally sampled by active functional clock edge. FA21 value must be stored inside AccessTime register bit field.
- (3) FA20 parameter illustrates amount of time required to internally sample successive input page data. It is expressed in number of GPMC functional clock cycles. After each access to input page data, next input page data is internally sampled by active functional clock edge after FA20 functional clock cycles. FA20 is also the duration of address phases for successive input page data (excluding first input page data). FA20 value must be stored in PageBurstAccessTime register bit field.
- (4) GPMC_FCLK is an internal clock (GPMC functional clock) not provided externally.

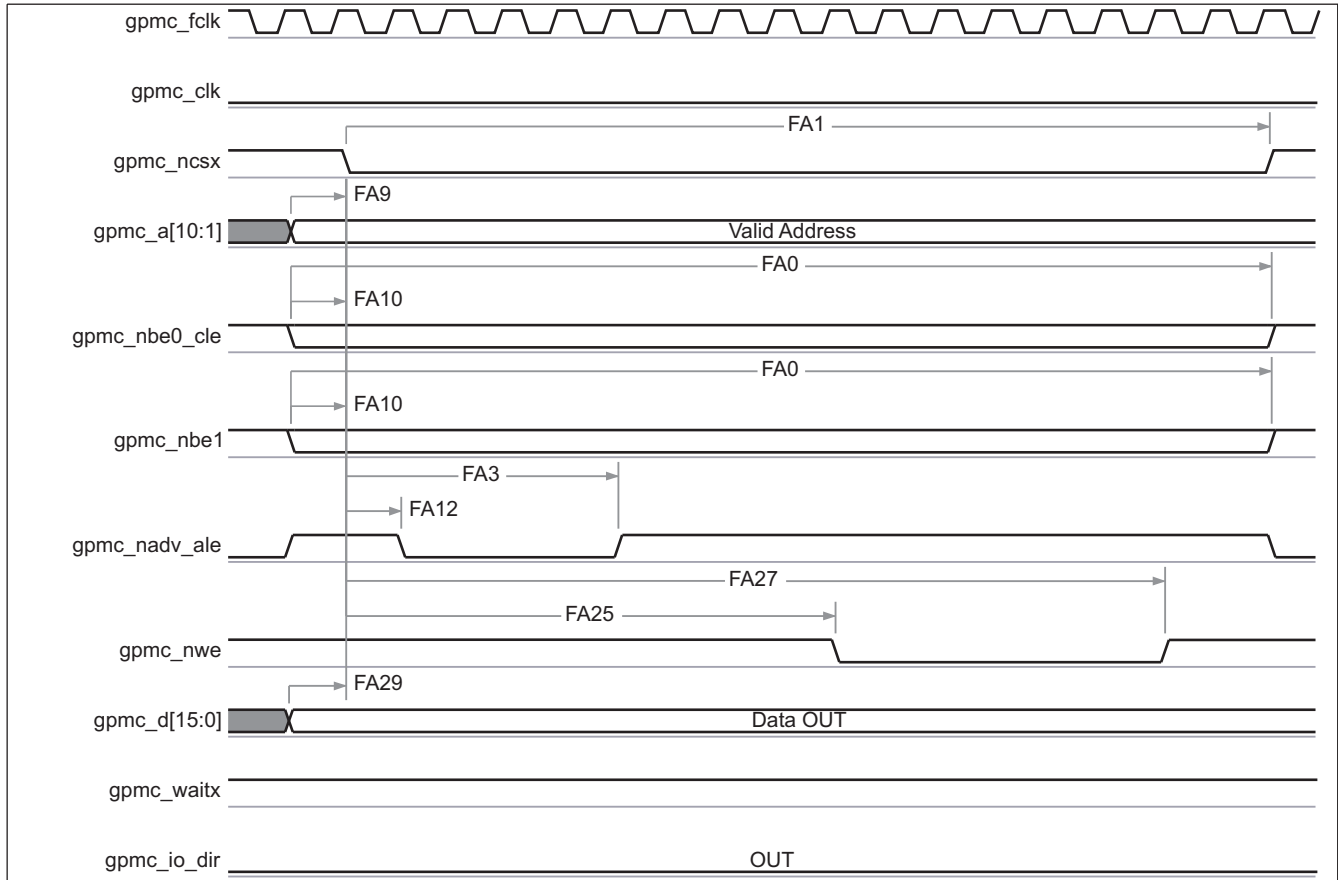

030-029

In gpmc_ncsx, x is equal to 0, 1, 2, 3, 4, 5, 6, or 7. In gpmc_waitx, x is equal to 0, 1, 2, or 3.

Figure 6-10. GPMC/NOR Flash – Asynchronous Write – Single Word Timing

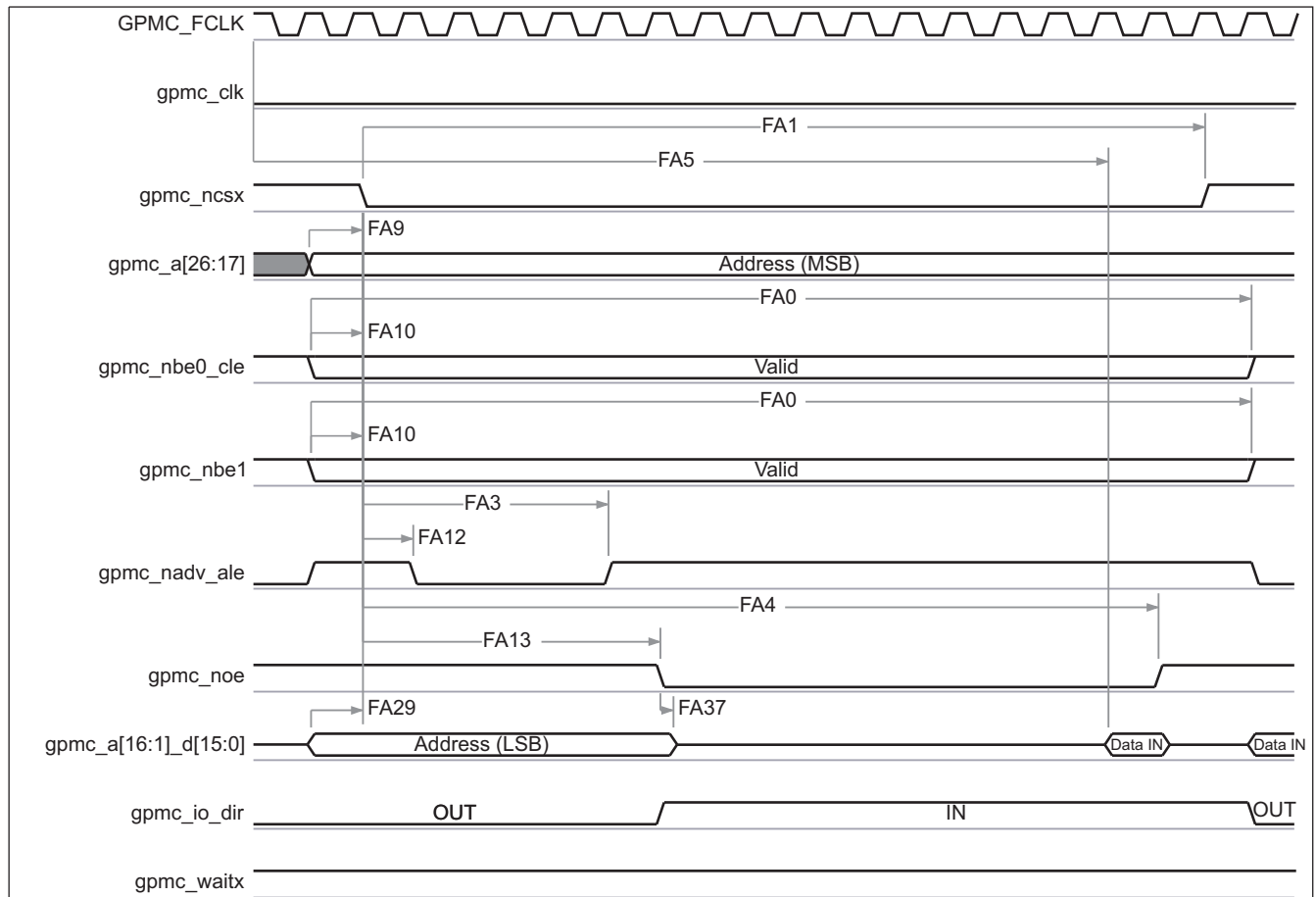

030-030

PRODUCT PREVIEW

Figure 6-11. GPMC/Multiplexed NOR Flash – Asynchronous Read – Single Word Timing⁽¹⁾⁽²⁾⁽³⁾

- (1) In gpmc_ncsx, x is equal to 0, 1, 2, 3, 4, 5, 6, or 7. In gpmc_waitx, x is equal to 0, 1, 2, or 3.
- (2) FA5 parameter illustrates amount of time required to internally sample input data. It is expressed in number of GPMC functional clock cycles. From start of read cycle and after FA5 functional clock cycles, input data is internally sampled by active functional clock edge. FA5 value must be stored inside AccessTime register bit field.
- (3) GPMC_FCLK is an internal clock (GPMC functional clock) not provided externally.

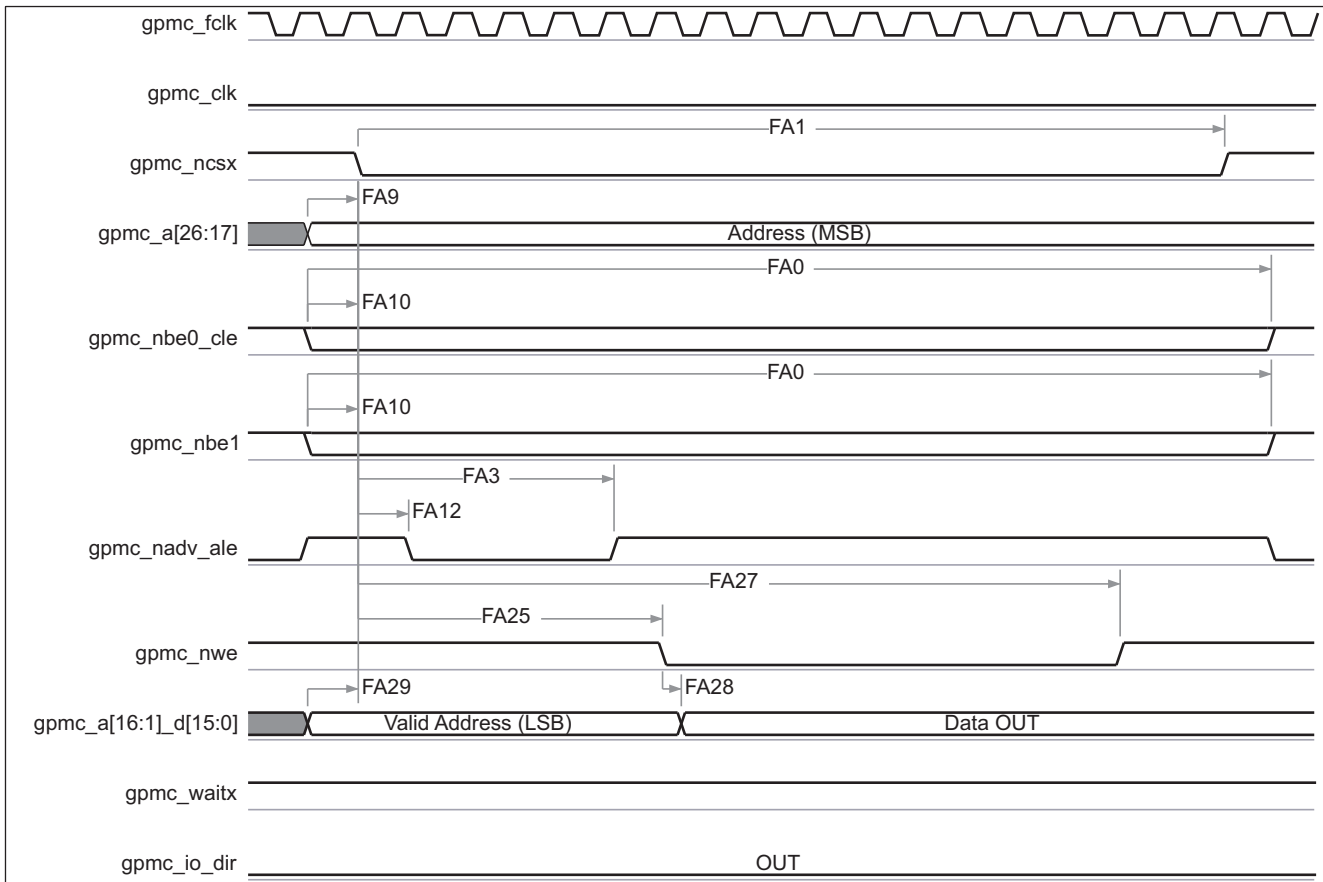

030-031

In gpmc_ncsx, x is equal to 0, 1, 2, 3, 4, 5, 6, or 7. In gpmc_waitx, x is equal to 0, 1, 2, or 3.

Figure 6-12. GPMC/Multiplexed NOR Flash – Asynchronous Write – Single Word Timing

6.4.1.3 GPMC/NAND Flash Interface Timing

Table 6-10 through Table 6-12 assume testing over the recommended operating conditions (see Figure 6-13 through Figure 6-16) and electrical characteristic conditions.

Table 6-9. GPMC/NAND Flash Asynchronous Mode Timing Conditions

TIMING CONDITION PARAMETER		VALUE	UNIT
Input Conditions			
t _R	Input signal rise time	1.8	ns
t _F	Input signal fall time	1.8	ns
Output Conditions			
C _{LOAD}	Output load capacitance	15.94	pF

Table 6-10. GPMC/NAND Flash Interface Asynchronous Timing – Internal Parameters⁽¹⁾⁽²⁾

NO.	PARAMETER	1.15 V		1.0 V		0.9 V		UNIT
		MIN	MAX	MIN	MAX	MIN	MAX	
GNFI1	Maximum output data generation delay from internal functional clock		6.5		9.1		13.7	ns
GNFI2	Maximum input data capture delay by internal functional clock		4		5.6		8.1	ns
GNFI3	Maximum device select generation delay from internal functional clock		6.5		9.1		13.7	ns

Table 6-10. GPMC/NAND Flash Interface Asynchronous Timing – Internal Parameters⁽¹⁾⁽²⁾ (continued)

NO.	PARAMETER	1.15 V		1.0 V		0.9 V		UNIT
		MIN	MAX	MIN	MAX	MIN	MAX	
GNFI4	Maximum address latch enable generation delay from internal functional clock		6.5		9.1		13.7	ns
GNFI5	Maximum command latch enable generation delay from internal functional clock		6.5		9.1		13.7	ns
GNFI6	Maximum output enable generation delay from internal functional clock		6.5		9.1		13.7	ns
GNFI7	Maximum write enable generation delay from internal functional clock		6.5		9.1		13.7	ns
GNFI8	Maximum functional clock skew		100		170		200	ps

(1) Internal parameters table must be used to calculate data access time stored in the corresponding CS register bit field.

(2) Internal parameters are referred to the GPMC functional internal clock which is not provided externally.

Table 6-11. GPMC/NAND Flash Interface Timing Requirements

NO.	PARAMETER		1.15 V		1.0 V		0.9 V		UNIT
			MIN	MAX	MIN	MAX	MIN	MAX	
GNF12 ⁽¹⁾	t _{acc(DAT)}	Data maximum access time		J ⁽²⁾		J ⁽²⁾		J ⁽²⁾	GPMC_FCLK cycles

(1) The GNF12 parameter illustrates the amount of time required to internally sample input data. It is expressed in number of GPMC functional clock cycles. From start of the read cycle and after GNF12 functional clock cycles, input data is internally sampled by the active functional clock edge. The GNF12 value must be stored inside AccessTime register bit field.

(2) J = AccessTime * (TimeParaGranularity + 1)

Table 6-12. GPMC/NAND Flash Interface Switching Characteristics

NO.	PARAMETER		1.15 V		1.0 V		0.9 V		UNIT
			MIN	MAX	MIN	MAX	MIN	MAX	
	t _{R(DO)}	Rise time, output data		2.0		2.0		2.0	ns
	t _{F(DO)}	Fall time, output data		2.0		2.0		2.0	ns
GNF0	t _{w(nWEV)}	Pulse duration, gpmc_nwe valid time	A ⁽¹⁾		A ⁽¹⁾		A ⁽¹⁾		ns
GNF1	t _{d(nCSV-nWEV)}	Delay time, gpmc_ncsx ⁽¹³⁾ valid to gpmc_nwe valid	B ⁽²⁾ – 0.2	B ⁽²⁾ + 2.0	B ⁽²⁾ – 0.2	B ⁽²⁾ + 2.6	B ⁽²⁾ – 0.2	B ⁽²⁾ + 3.7	ns
GNF2	t _{w(CLEH-nWEV)}	Delay time, gpmc_nbe0_cle high to gpmc_nwe valid	C ⁽³⁾ – 0.2	C ⁽³⁾ + 2.0	C ⁽³⁾ – 0.2	C ⁽³⁾ + 2.6	C ⁽³⁾ – 0.2	C ⁽³⁾ + 3.7	ns
GNF3	t _{w(nWEV-DV)}	Delay time, gpmc_d[15:0] valid to gpmc_nwe valid	D ⁽⁴⁾ – 0.2	D ⁽⁴⁾ + 2.0	D ⁽⁴⁾ – 0.2	D ⁽⁴⁾ + 2.6	D ⁽⁴⁾ – 0.2	D ⁽⁴⁾ + 3.7	ns
GNF4	t _{w(nWEIV-DIV)}	Delay time, gpmc_nwe invalid to gpmc_d[15:0] invalid	E ⁽⁵⁾ – 0.2	E ⁽⁵⁾ + 2.0	E ⁽⁵⁾ – 0.2	E ⁽⁵⁾ + 2.6	E ⁽⁵⁾ – 0.2	E ⁽⁵⁾ + 3.7	ns
GNF5	t _{w(nWEIV-CLEIV)}	Delay time, gpmc_nwe invalid to gpmc_nbe0_cle invalid	F ⁽⁶⁾ – 0.2	F ⁽⁶⁾ + 2.0	F ⁽⁶⁾ – 0.2	F ⁽⁶⁾ + 2.6	F ⁽⁶⁾ – 0.2	F ⁽⁶⁾ + 3.7	ns

Table 6-12. GPMC/NAND Flash Interface Switching Characteristics (continued)

NO.	PARAMETER		1.15 V		1.0 V		0.9 V		UNIT
			MIN	MAX	MIN	MAX	MIN	MAX	
GNF6	$t_{w(nWEIV-nCSIV)}$	Delay time, gpmc_nwe invalid to gpmc_ncsx ⁽¹³⁾ invalid	$G^{(7)} - 0.2$	$G^{(7)} + 2.0$	$G^{(7)} - 0.2$	$G^{(7)} + 2.6$	$G^{(7)} - 0.2$	$G^{(7)} + 3.7$	ns
GNF7	$t_{w(ALEH-nWEV)}$	Delay time, gpmc_nadv_ale High to gpmc_nwe valid	$C^{(3)} - 0.2$	$C^{(3)} + 2.0$	$C^{(3)} - 0.2$	$C^{(3)} + 2.6$	$C^{(3)} - 0.2$	$C^{(3)} + 3.7$	ns
GNF8	$t_{w(nWEIV-ALEIV)}$	Delay time, gpmc_nwe invalid to gpmc_nadv_ale invalid	$F^{(6)} - 0.2$	$F^{(6)} + 2.0$	$F^{(6)} - 0.2$	$F^{(6)} + 2.6$	$F^{(6)} - 0.2$	$F^{(6)} + 3.7$	ns
GNF9	$t_{c(nWE)}$	Cycle time, Write cycle time	$H^{(8)}$		$H^{(8)}$		$H^{(8)}$		ns
GNF10	$t_{d(nCSV-nOEV)}$	Delay time, gpmc_ncsx ⁽¹³⁾ valid to gpmc_noe valid	$I^{(9)} - 0.2$	$I^{(9)} + 2.0$	$I^{(9)} - 0.2$	$I^{(9)} + 2.6$	$I^{(9)} - 0.2$	$I^{(9)} + 3.7$	ns
GNF13	$t_{w(nOEV)}$	Pulse duration, gpmc_noe valid time	$K^{(10)}$		$K^{(10)}$		$K^{(10)}$		ns
GNF14	$t_{c(nOE)}$	Cycle time, Read cycle time	$L^{(11)}$		$L^{(11)}$		$L^{(11)}$		ns
GNF15	$t_{w(nOEIV-nCSIV)}$	Delay time, gpmc_noe invalid to gpmc_ncsx ⁽¹³⁾ invalid	$M^{(12)} - 0.2$	$M^{(12)} + 2.0$	$M^{(12)} - 0.2$	$M^{(12)} + 2.6$	$M^{(12)} - 0.2$	$M^{(12)} + 3.7$	ns

- (1) $A = (WEOffTime - WEOnTime) * (TimeParaGranularity + 1) * GPMC_FCLK$
- (2) $B = ((WEOnTime - CSONTime) * (TimeParaGranularity + 1) + 0.5 * (WEEExtraDelay - CSEExtraDelay)) * GPMC_FCLK$
- (3) $C = ((WEOnTime - ADVOnTime) * (TimeParaGranularity + 1) + 0.5 * (WEEExtraDelay - ADVExtraDelay)) * GPMC_FCLK$
- (4) $D = (WEOnTime * (TimeParaGranularity + 1) + 0.5 * WEEExtraDelay) * GPMC_FCLK$
- (5) $E = (WrCycleTime - WEOffTime * (TimeParaGranularity + 1) - 0.5 * WEEExtraDelay) * GPMC_FCLK$
- (6) $F = (ADVWrOffTime - WEOffTime * (TimeParaGranularity + 1) + 0.5 * (ADVExtraDelay - WEEExtraDelay)) * GPMC_FCLK$
- (7) $G = (CSWrOffTime - WEOffTime * (TimeParaGranularity + 1) + 0.5 * (CSEExtraDelay - WEEExtraDelay)) * GPMC_FCLK$
- (8) $H = WrCycleTime * (1 + TimeParaGranularity) * GPMC_FCLK$
- (9) $I = ((OEOnTime - CSONTime) * (TimeParaGranularity + 1) + 0.5 * (OEEExtraDelay - CSEExtraDelay)) * GPMC_FCLK$
- (10) $K = (OEOffTime - OEOnTime) * (1 + TimeParaGranularity) * GPMC_FCLK$
- (11) $L = RdCycleTime * (1 + TimeParaGranularity) * GPMC_FCLK$
- (12) $M = (CSRdOffTime - OEOffTime * (TimeParaGranularity + 1) + 0.5 * (CSEExtraDelay - OEEExtraDelay)) * GPMC_FCLK$
- (13) In gpmc_ncsx, x is equal to 0, 1, 2, 3, 4, 5, 6, or 7.

PRODUCT PREVIEW

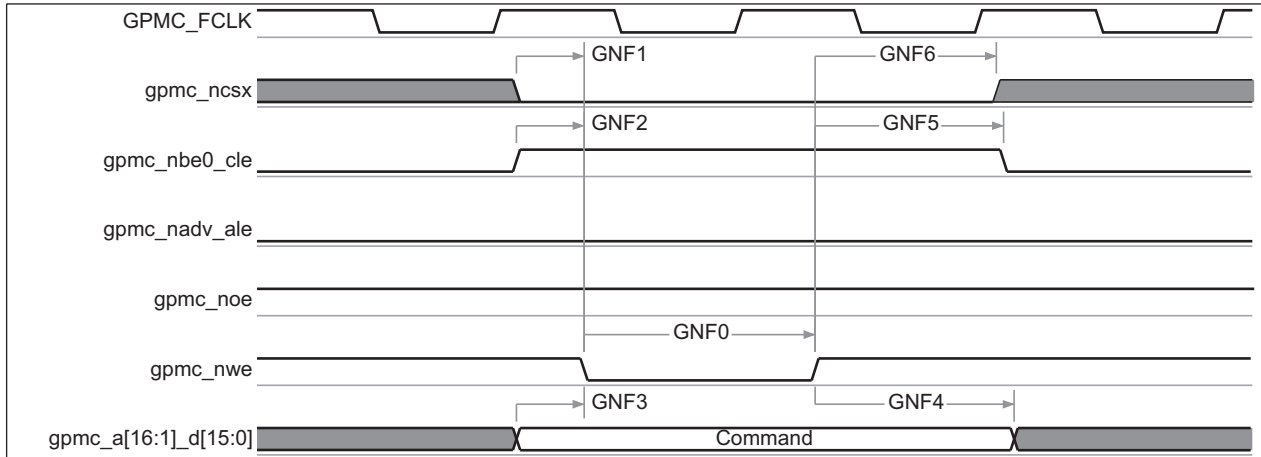

030-032

In gpmc_ncsx, x is equal to 0, 1, 2, 3, 4, 5, 6, or 7.

Figure 6-13. GPMC/NAND Flash – Command Latch Cycle Timing

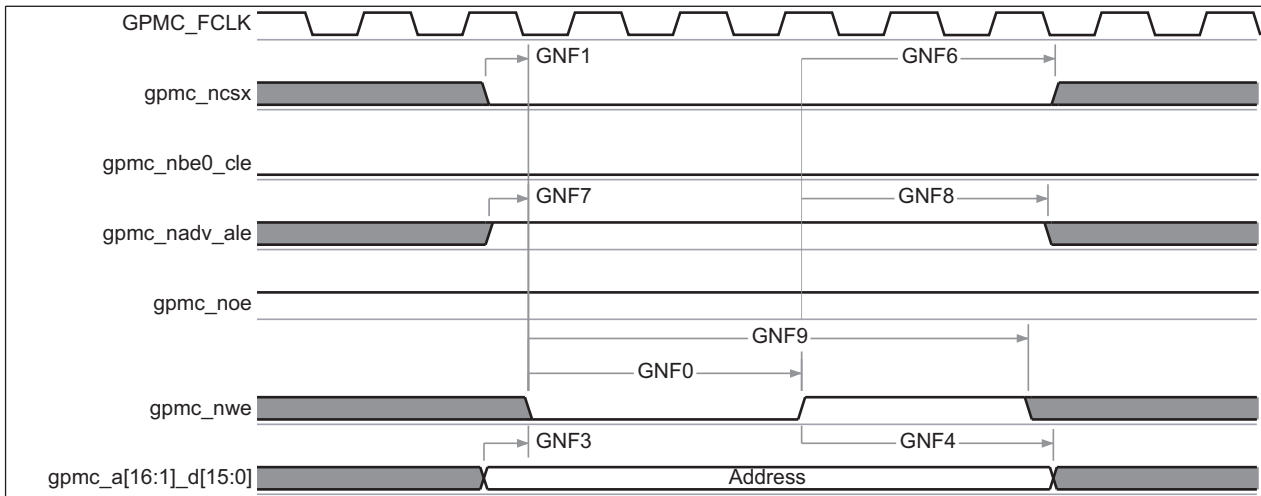

030-033

In gpmc_ncsx, x is equal to 0, 1, 2, 3, 4, 5, 6, or 7.

Figure 6-14. GPMC/NAND Flash – Address Latch Cycle Timing

PRODUCT PREVIEW

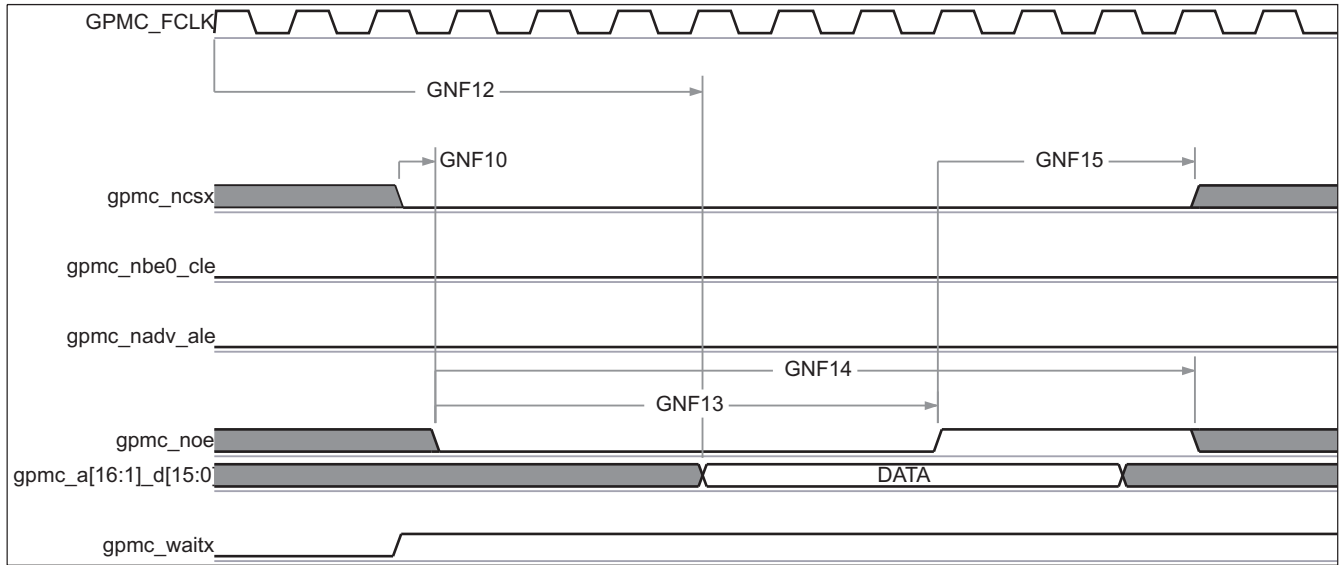

030-034

Figure 6-15. GPMC/NAND Flash – Data Read Cycle Timing⁽¹⁾⁽²⁾⁽³⁾

- (1) The GNF12 parameter illustrates amount of time required to internally sample input data. It is expressed in number of GPMC functional clock cycles. From start of read cycle and after GNF12 functional clock cycles, input data is internally sampled by active functional clock edge. The GNF12 value must be stored inside AccessTime register bit field.
- (2) GPMC_FCLK is an internal clock (GPMC functional clock) not provided externally.
- (3) In gpmc_ncsx, x is equal to 0, 1, 2, 3, 4, 5, 6, or 7. In gpmc_waitx, x is equal to 0, 1, 2, or 3.

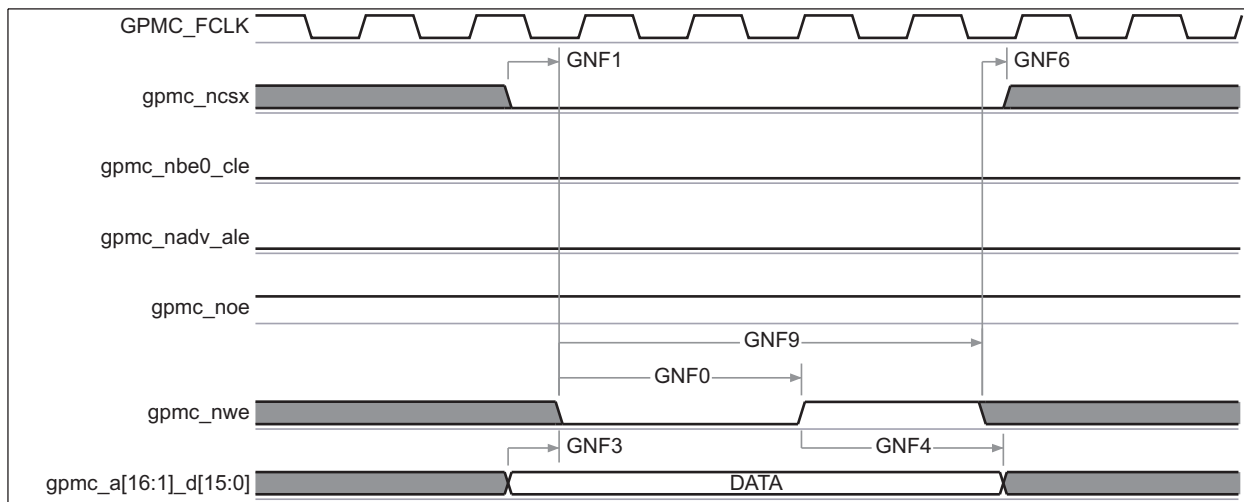

030-035

In gpmc_ncsx, x is equal to 0, 1, 2, 3, 4, 5, 6, or 7. In gpmc_waitx, x is equal to 0 or 1.

Figure 6-16. GPMC/NAND Flash – Data Write Cycle Timing

6.4.2 SDRAM Controller Subsystem (SDRC)

The SDRAM controller subsystem (SDRC) module provides connectivity between the OMAP3530/2530/2530/2530/25 Applications Processor and external DRAM memory components. The SDRC module only supports low-power double-data-rate (LPDDR) SDRAM devices. Memory devices can be interfaced to the SDRC using a stacked-memory approach or through the printed circuit board (PCB). The stacked-memory approach uses the package-on-package memory interface pins (available only on CBB package).

The approach to specifying interface timing for the SDRC memory bus is different than on other interfaces such as the general-purpose memory controller (GPMC) and the multi-channel buffered serial ports (McBSPs). For these other interfaces the device timing was specified in terms of data manual specifications and I/O buffer information specification (IBIS) models.

For the SDRC memory bus, the approach is to specify compatible memory devices and provide the printed circuit board (PCB) solution and guidelines directly to the user. Texas Instruments (TI) has performed the simulation and system characterization to ensure all interface timings in this solution are met. The complete PCB memory system solution is documented in the TBD application report (literature number SPRATBD). Guidelines on using the stacked-memory approach are described in the TBD application report (literature number SPRATBD).

TI only supports designs that use supported memory devices and follow the board design guidelines outlined in the SPRATBD application report.

6.5 Video Interfaces

6.5.1 Camera Interface

The camera subsystem provides the system interfaces and the processing capability to connect raw, YUV, or JPEG image sensor modules to the OMAP3515/03 device for video-preview, video-record, and still-image-capture applications. The camera subsystem supports up to two simultaneous pixel flows but only one of them can use the video processing hardware:

- PARALLEL: the parallel interface data must go through the video processing hardware.

6.5.1.1 Parallel Camera Interface Timing

The parallel camera interface is a 12-bit interface which can be used in two modes:

1. SYNC mode: progressive and interlaced image sensor modules for 8-, 10-, 11-, and 12-bit data. The pixel clock can be up to 75 MHz in 12-bit mode. The pixel clock can be up to 130 MHz in 8-bit packed mode.
2. ITU mode provides an ITU-R BT 656 compatible data stream with progressive image sensor modules only in 8- and 10-bit configurations. The pixel clock can be up to 150 MHz in 8-bit packed mode (up to 75 MHz in 10-bit mode)

6.5.1.1.1 SYNC Normal Mode

6.5.1.1.1.1 12-Bit SYNC Normal – Progressive Mode

Table 6-14 and Table 6-15 assume testing over the recommended operating conditions and electrical characteristic conditions (see Figure 6-17).

Table 6-13. ISP Timing Conditions – 12-Bit SYNC Normal – Progressive Mode

TIMING CONDITION PARAMETER		VALUE	UNIT
Input Conditions			
t_R	Input signal rise time	2.7	ns
t_F	Input signal fall time	2.7	ns
Output Condition			
C_{LOAD}	Output load capacitance	8.6	pF

Table 6-14. ISP Timing Requirements – 12-Bit SYNC Normal – Progressive Mode⁽⁴⁾

NO.	PARAMETER		1.15 V		1.0 V		UNIT
			MIN	MAX	MIN	MAX	
ISP17	$t_{c(pclk)}$	Cycle time ⁽¹⁾ , cam_pclk period	13.3		22.2		ns
ISP18	$t_{W(pclkH)}$	Typical pulse duration, cam_pclk high	0.5*P ⁽²⁾		0.5*P ⁽²⁾		ns
ISP18	$t_{W(pclkL)}$	Typical pulse duration, cam_pclk low	0.5*P ⁽²⁾		0.5*P ⁽²⁾		ns
	$t_{dc(pclk)}$	Duty cycle error, cam_pclk		667		1111	ps
	$t_{j(pclk)}$	Cycle jitter ⁽³⁾ , cam_pclk		133		200	ps
ISP19	$t_{su(dV-pclkH)}$	Setup time, cam_d[11:0] valid before cam_pclk rising edge	1.82		3.25		ns
ISP20	$t_{h(pclkH-dV)}$	Hold time, cam_d[11:0] valid after cam_pclk rising edge	1.82		3.25		ns
ISP21	$t_{su(dV-vsH)}$	Setup time, cam_vs valid before cam_pclk rising edge	1.82		3.25		ns
ISP22	$t_{h(pclkH-vsV)}$	Hold time, cam_vs valid after cam_pclk rising edge	1.82		3.25		ns
ISP23	$t_{su(dV-hsH)}$	Setup time, cam_hs valid before cam_pclk rising edge	1.82		3.25		ns
ISP24	$t_{h(pclkH-hsV)}$	Hold time, cam_hs valid after cam_pclk rising edge	1.82		3.25		ns
ISP25	$t_{su(dV-hsH)}$	Setup time, cam_wen valid before cam_pclk rising edge	1.82		3.25		ns

Table 6-14. ISP Timing Requirements – 12-Bit SYNC Normal – Progressive Mode⁽⁴⁾ (continued)

NO.	PARAMETER		1.15 V		1.0 V		UNIT
			MIN	MAX	MIN	MAX	
ISP26	$t_{h(pclkH-hsV)}$	Hold time, cam_wen valid after cam_pclk rising edge	1.82		3.25		ns

- (1) Related with the input maximum frequency supported by the ISP module.
- (2) P = cam_pclk period in ns
- (3) Maximum cycle jitter supported by cam_pclk input clock.
- (4) The timing requirements are assured for the cycle jitter and duty cycle error conditions specified.

Table 6-15. ISP Switching Characteristics – 12-Bit SYNC Normal – Progressive Mode

NO.	PARAMETER		1.15 V		1.0 V		UNIT
			MIN	MAX	MIN	MAX	
ISP15	$t_{c(xclk)}$	Cycle time ⁽¹⁾ , cam_xclk period	4.6		4.6		ns
ISP16	$t_{W(xclkH)}$	Typical pulse duration, cam_xclk high	0.5*PO ⁽²⁾		0.5*PO ⁽²⁾		ns
ISP16	$t_{W(xclkL)}$	Typical pulse duration, cam_xclk low	0.5*PO ⁽²⁾		0.5*PO ⁽²⁾		ns
	$t_{dc(xclk)}$	Duty cycle error, cam_xclk		231		231	ps
	$t_{j(xclk)}$	Jitter standard deviation ⁽³⁾ , cam_xclk		33		33	ps
	$t_{R(xclk)}$	Rise time, cam_xclk		0.93		0.93	ns
	$t_{F(xclk)}$	Fall time, cam_xclk		0.93		0.93	ns

- (1) Related with the cam_xclk maximum and minimum frequencies programmable in the ISP module.
Warning: The camera sensor or the camera module must be disabled to change the frequency configuration. For more information, see the *OMAP35xx ES2.0 Technical Reference Manual (TRM)* [literature number [SPRUJ98](#)].
- (2) PO = cam_xclk period in ns
- (3) The jitter probability density can be approximated by a Gaussian function.

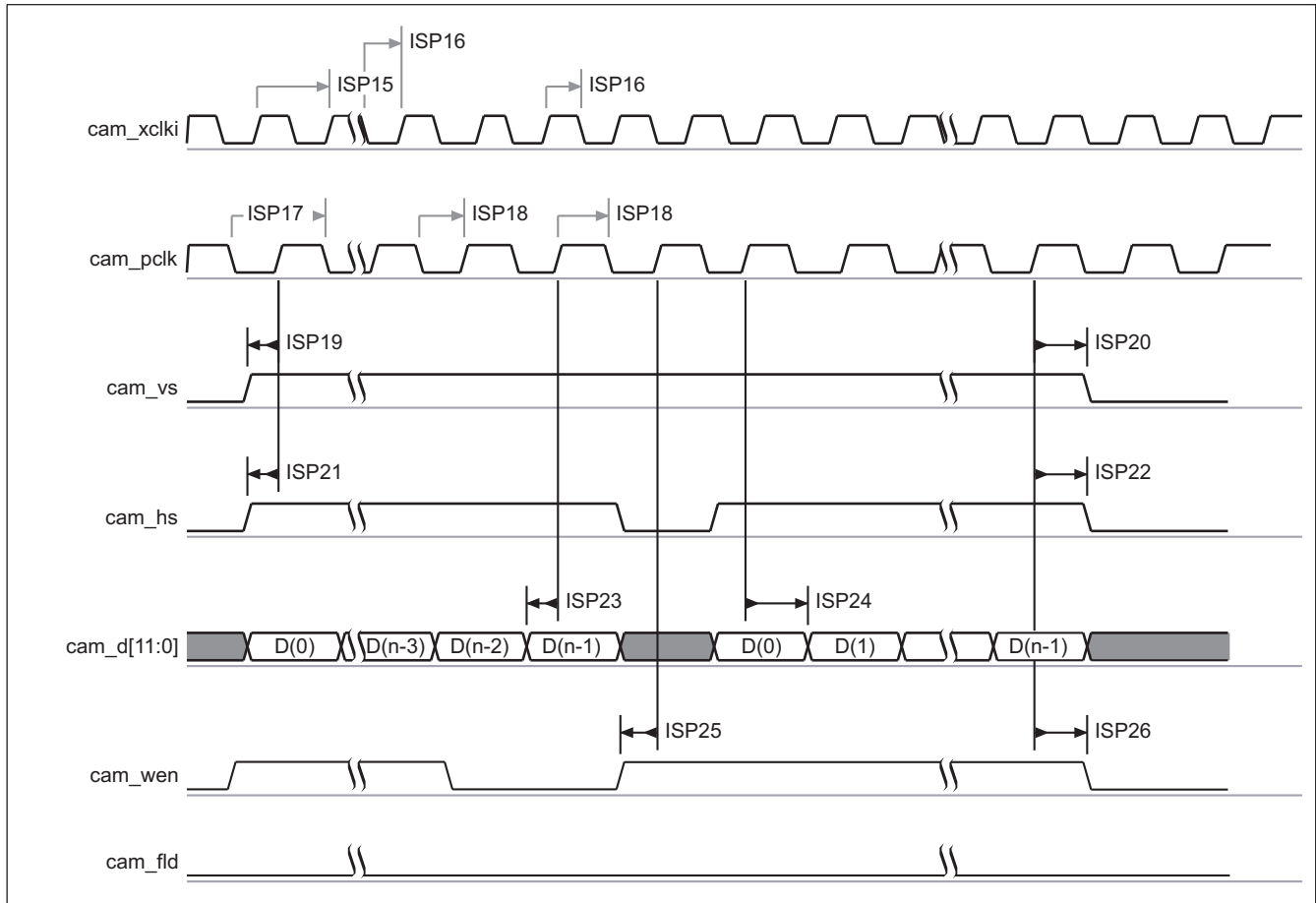

030-056

Figure 6-17. ISP – 12-Bit SYNC Normal – Progressive Mode⁽¹⁾⁽²⁾⁽³⁾⁽⁴⁾⁽⁵⁾⁽⁶⁾⁽⁷⁾⁽⁸⁾

- (1) The polarity of cam_pclk, cam_fld, cam_vs, and cam_hs are configurable. If the cam_hs, cam_vs, and cam_fld signals are output, the signal length can be set.
- (2) The parallel camera in SYNC mode supports progressive image sensor modules and 8-, 10-, 11-, or 12-bit data.
- (3) When the image sensor has fewer than 12 data lines, it must be connected to the lower data lines and the unused lines must be grounded.
- (4) However, it is possible to shift the data to 0, 2, or 4 data internal lanes.
- (5) The bit configurations are: cam_d[11:4] or cam_d[7:0] in 8-bit mode, cam_d[11:2] or cam_d[9:0] in 10-bit mode, cam_d[10:0] in 11-bit mode, and cam_d[11:0] in 12-bit mode.
- (6) Optionally, the data write to memory can be qualified by the external cam_wen signal.
- (7) The cam_wen signal can be used as a external memory write-enable signal. The data is stored to memory only if cam_hs, cam_vs, and cam_wen signals are asserted.
- (8) In cam_xclki; l is equal to a or b.

6.5.1.1.1.2 8-bit Packed SYNC – Progressive Mode

Table 6-17 and Table 6-18 assume testing over the recommended operating conditions and electrical characteristic conditions (see Figure 6-18).

Table 6-16. ISP Timing Conditions – 8-bit Packed SYNC – Progressive Mode

TIMING CONDITION PARAMETER		VALUE	UNIT
Input Conditions			
t _R	Input signal rise time	2.5	ns
t _F	Input signal fall time	2.5	ns
Output Conditions			

Table 6-16. ISP Timing Conditions – 8-bit Packed SYNC – Progressive Mode (continued)

TIMING CONDITION PARAMETER		VALUE	UNIT
C _{LOAD}	Output load capacitance	8.6	pF

Table 6-17. ISP Timing Requirements – 8-bit Packed SYNC – Progressive Mode⁽⁴⁾

NO.	PARAMETER		1.15 V		1.0 V		UNIT
			MIN	MAX	MIN	MAX	
ISP3	t _c (pclk)	Cycle time ⁽¹⁾ , cam_pclk period	7.7		15.4		ns
ISP4	t _W (pclkH)	Typical pulse duration, cam_pclk high	0.5*P ⁽²⁾		0.5*P ⁽²⁾		ns
ISP4	t _W (pclkL)	Typical pulse duration, cam_pclk low	0.5*P ⁽²⁾		0.5*P ⁽²⁾		ns
	t _{dc} (pclk)	Duty cycle error, cam_pclk		385		769	ps
	t _j (pclk)	Cycle jitter ⁽³⁾ , cam_pclk		83		167	ps
ISP5	t _{su} (dV-pclkH)	Setup time, cam_d[11:0] valid before cam_pclk rising edge	1.08		2.27		ns
ISP6	t _h (pclkH-dV)	Hold time, cam_d[11:0] valid after cam_pclk rising edge	1.08		2.27		ns
ISP7	t _{su} (dV-vsH)	Setup time, cam_vs valid before cam_pclk rising edge	1.08		2.27		ns
ISP8	t _h (pclkH-vsV)	Hold time, cam_vs valid after cam_pclk rising edge	1.08		2.27		ns
ISP9	t _{su} (dV-hsH)	Setup time, cam_hs valid before cam_pclk rising edge	1.08		2.27		ns
ISP10	t _h (pclkH-hsV)	Hold time, cam_hs valid after cam_pclk rising edge	1.08		2.27		ns
ISP11	t _{su} (dV-hsH)	Setup time, cam_wen valid before cam_pclk rising edge	1.08		2.27		ns
ISP12	t _h (pclkH-hsV)	Hold time, cam_wen valid after cam_pclk rising edge	1.08		2.27		ns

- (1) Related with the input maximum frequency supported by the ISP module.
- (2) P = cam_pclk period in ns.
- (3) Maximum cycle jitter supported by cam_pclk input clock.
- (4) The timing requirements are assured for the cycle jitter and duty cycle error conditions specified.

Table 6-18. ISP Switching Characteristics – 8-bit packed SYNC – Progressive Mode

NO.	PARAMETER		1.15 V		1.0 V		UNIT
			MIN	MAX	MIN	MAX	
ISP1	t _c (xclk)	Cycle time ⁽¹⁾ , cam_xclk period	4.6		4.6		ns
ISP2	t _W (xclkH)	Typical pulse duration, cam_xclk high	0.5*PO ⁽²⁾		0.5*PO ⁽²⁾		ns
ISP2	t _W (xclkL)	Typical pulse duration, cam_xclk low	0.5*PO ⁽²⁾		0.5*PO ⁽²⁾		ns
	t _{dc} (xclk)	Duty cycle error, cam_xclk		231		231	ps
	t _j (xclk)	Jitter standard deviation ⁽³⁾ , cam_xclk		67		67	ps
	t _R (xclk)	Rise time, cam_xclk		0.93		0.93	ns
	t _F (xclk)	Fall time, cam_xclk		0.93		0.93	ns

- (1) Related with the cam_xclk maximum and minimum frequencies programmable in the ISP module.
Warning: You must disable the camera sensor or the camera module to change the frequency configuration. For more information, see the *OMAP35xx ES2.0 Technical Reference Manual (TRM)* [literature number [SPRUJ98](#)].
- (2) PO = cam_xclk period in ns
- (3) The jitter probability density can be approximated by a Gaussian function.

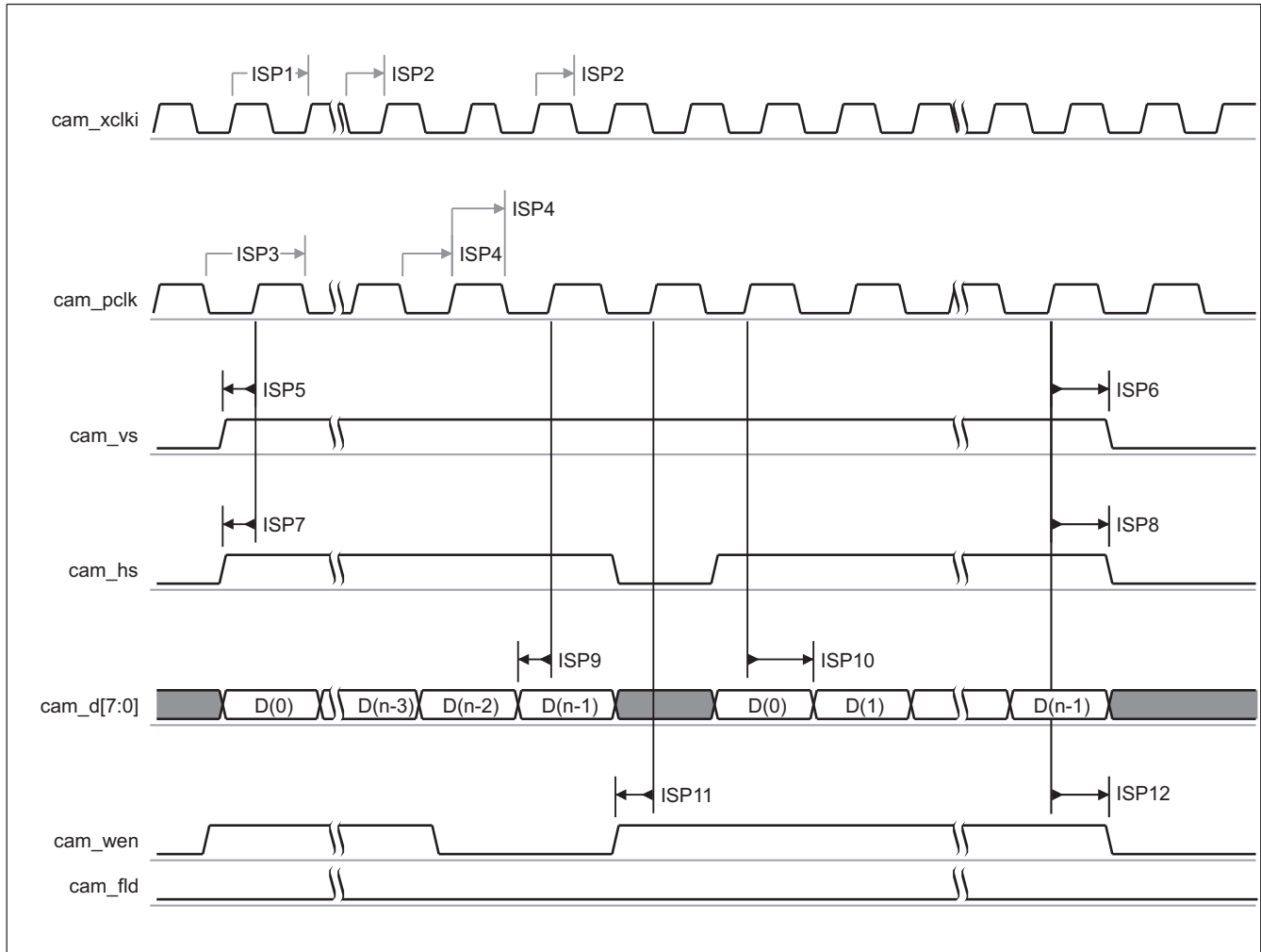

030-059

Figure 6-18. ISP – 8-bit Packed SYNC – Progressive Mode⁽¹⁾⁽²⁾⁽³⁾⁽⁴⁾⁽⁵⁾

- (1) The polarity of cam_pclk, cam_fld, cam_vs, and cam_hs are configurable.
- (2) The image sensor must be connected to the lower data lines and the unused lines must be grounded. However, it is possible to shift the data to 0, 2, or 4 data internal lanes. The bit configurations are: cam_d[11:4] or cam_d[7:0] in 8-bit packed mode.
- (3) Optionally, the data write to memory can be qualified by the external cam_wen signal. The cam_wen signal can be used as a external memory write-enable signal. The data is stored to memory only if cam_hs, cam_vs, and cam_wen signals are asserted. The polarity of cam_fld is programmable.
- (4) The camera module can pack 8-bit data into 16 bits. It doubles the maximum pixel clock. This mode can be particularly useful to transfer a YCbCr data stream or compressed stream to memory at very high speed.
- (5) In cam_xclki; I is equal to a or b.

6.5.1.1.1.3 12-Bit SYNC Normal – Interlaced Mode

Table 6-20 and Table 6-21 assume testing over the recommended operating conditions and electrical characteristic conditions (see Figure 6-19).

Table 6-19. ISP Timing Conditions – 12-Bit SYNC Normal – Interlaced Mode

TIMING CONDITION PARAMETER		VALUE	UNIT
Input Conditions			
t _R	Input signal rise time	2.7	ns
t _F	Input signal fall time	2.7	ns
Output Conditions			

Table 6-19. ISP Timing Conditions – 12-Bit SYNC Normal – Interlaced Mode (continued)

TIMING CONDITION PARAMETER		VALUE	UNIT
C _{LOAD}	Output load capacitance	8.6	pF

Table 6-20. ISP Timing Requirements – 12-Bit SYNC Normal – Interlaced Mode⁽⁴⁾

NO.	PARAMETER		1.15 V		1.0 V		UNIT
			MIN	MAX	MIN	MAX	
ISP17	t _{c(pclk)}	Cycle time ⁽¹⁾ , cam_pclk period	13.3		22.2		ns
ISP18	t _{W(pclkH)}	Typical pulse duration, cam_pclk high	0.5*P ⁽²⁾		0.5*P ⁽²⁾		ns
ISP18	t _{W(pclkL)}	Typical pulse duration, cam_pclk low	0.5*P ⁽²⁾		0.5*P ⁽²⁾		ns
	t _{dc(pclk)}	Duty cycle error, cam_pclk		667		1111	ps
	t _{j(pclk)}	Cycle jitter ⁽³⁾ , cam_pclk		133		200	ps
ISP19	t _{su(dV-pclkH)}	Setup time, cam_d[11:0] valid before cam_pclk rising edge	1.82		3.25		ns
ISP20	t _{h(pclkH-dV)}	Hold time, cam_d[11:0] valid after cam_pclk rising edge	1.82		3.25		ns
ISP21	t _{su(dV-vsH)}	Setup time, cam_vs valid before cam_pclk rising edge	1.82		3.25		ns
ISP22	t _{h(pclkH-vsV)}	Hold time, cam_vs valid after cam_pclk rising edge	1.82		3.25		ns
ISP23	t _{su(dV-hsH)}	Setup time, cam_hs valid before cam_pclk rising edge	1.82		3.25		ns
ISP24	t _{h(pclkH-hsV)}	Hold time, cam_hs valid after cam_pclk rising edge	1.82		3.25		ns
ISP25	t _{su(dV-hsH)}	Setup time, cam_wen valid before cam_pclk rising edge	1.82		3.25		ns
ISP26	t _{h(pclkH-hsV)}	Hold time, cam_wen valid after cam_pclk rising edge	1.82		3.25		ns
ISP27	t _{su(dV-flidH)}	Setup time, cam_fld valid before cam_pclk rising edge	1.82		3.25		ns
ISP28	t _{h(pclkH-flidV)}	Hold time, cam_fld valid after cam_pclk rising edge	1.82		3.25		ns

- (1) Related with the input maximum frequency supported by the ISP module.
(2) P = cam_lclk period in ns.
(3) Maximum cycle jitter supported by cam_pclk input clock.
(4) The timing requirements are assured for the cycle jitter and duty cycle error conditions specified.

Table 6-21. ISP Switching Characteristics – 12-Bit SYNC Normal – Interlaced Mode

NO.	PARAMETER		1.15 V		1.0 V		UNIT
			MIN	MAX	MIN	MAX	
ISP15	t _{c(xclk)}	Cycle time ⁽¹⁾ , cam_xclk period	4.6		4.6		ns
ISP16	t _{W(xclkH)}	Typical pulse duration, cam_xclk high	0.5*PO ⁽²⁾		0.5*PO ⁽²⁾		ns
ISP16	t _{W(xclkL)}	Typical pulse duration, cam_xclk low	0.5*PO ⁽²⁾		0.5*PO ⁽²⁾		ns
	t _{dc(xclk)}	Duty cycle error, cam_xclk		231		231	ps
	t _{j(xclk)}	Jitter standard deviation ⁽³⁾ , cam_xclk		33		33	ps
	t _{R(xclk)}	Rise time, cam_xclk		0.93		0.93	ns
	t _{F(xclk)}	Fall time, cam_xclk		0.93		0.93	ns

- (1) Related with the cam_xclk maximum and minimum frequencies programmable in the ISP module.
Warning: You must disable the camera sensor or the camera module to change the frequency configuration. For more information, see the *OMAP35xx ES2.0 Technical Reference Manual (TRM)* [literature number [SPRUF98](#)].
(2) PO = cam_xclk period in ns.
(3) The jitter probability density can be approximated by a Gaussian function.

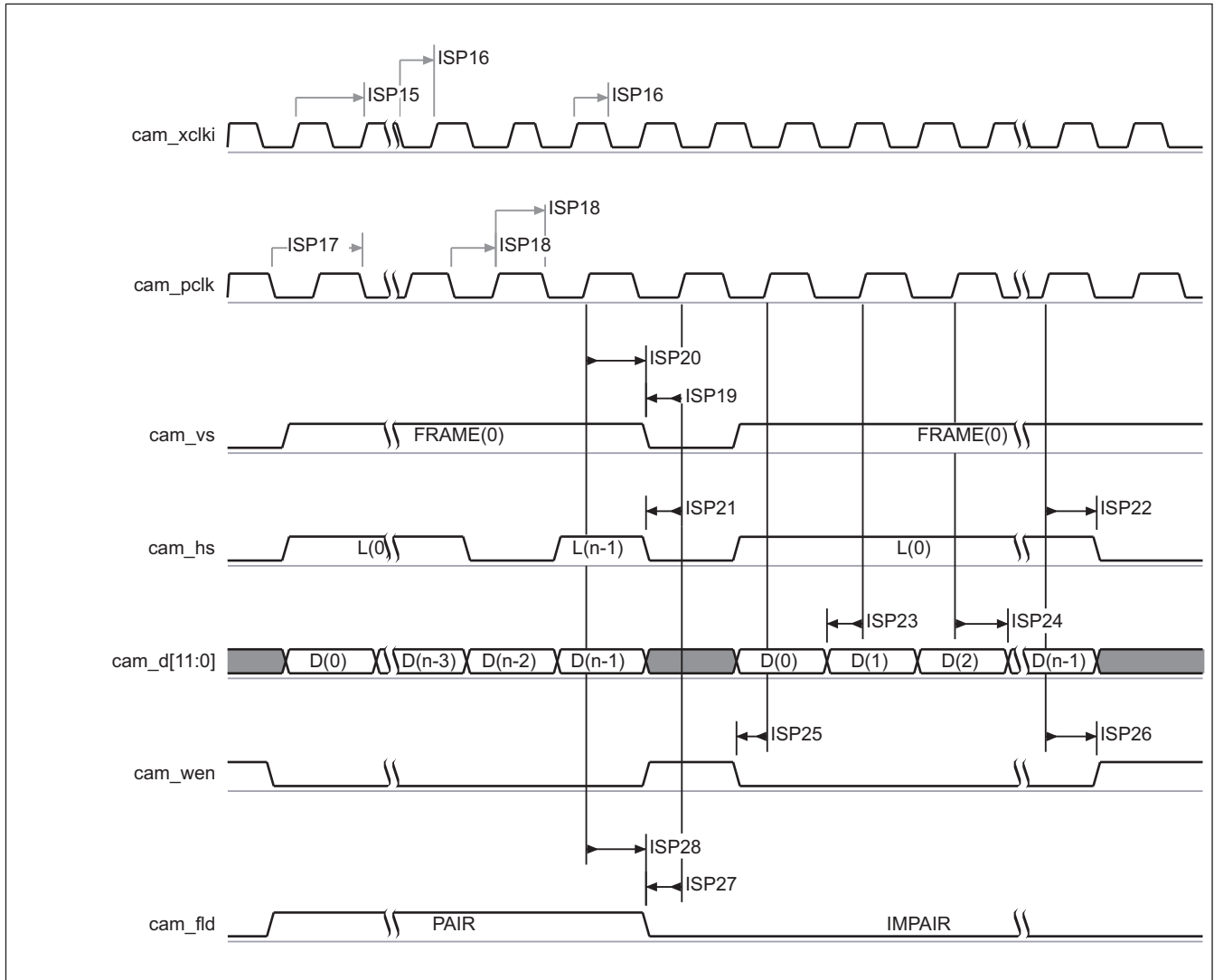

030-057

Figure 6-19. ISP – 12-Bit SYNC Normal – Interlaced Mode⁽¹⁾⁽²⁾⁽³⁾⁽⁴⁾⁽⁵⁾⁽⁶⁾⁽⁷⁾⁽⁸⁾

- (1) The polarity of cam_pclk, cam_fld, cam_vs, and cam_hs are configurable. If the cam_hs, cam_vs, and cam_fld signals are output, the signal length can be set.
- (2) The parallel camera in SYNC mode supports interlaced image sensor modules and 8-, 10-, 11-, or 12-bit data.
- (3) When the image sensor has fewer than 12 data lines, it must be connected to the lower data lines and the unused lines must be grounded.
- (4) It is possible to shift the data to 0, 2, or 4 data internal lanes.
- (5) The bit configurations are: cam_d[11:4] or cam_d[7:0] in 8-bit mode, cam_d[11:2] or cam_d[9:0] in 10-bit mode, cam_d[10:0] in 11-bit mode, and cam_d[11:0] in 12-bit mode.
- (6) Optionally, the data write to memory can be qualified by the external cam_wen signal.
- (7) The cam_wen signal can be used as a external memory write-enable signal. The data is stored to memory only if cam_hs, cam_vs, and cam_wen signals are asserted.
- (8) In cam_xclki; I is equal to a or b.

6.5.1.1.1.4 8-bit Packed SYNC – Interlaced Mode

Table 6-23 and Table 6-24 assume testing over the recommended operating conditions and electrical characteristic conditions (see Figure 6-20).

Table 6-22. ISP Timing Conditions – 8-bit Packed SYNC – Interlaced Mode

TIMING CONDITION PARAMETER		VALUE	UNIT
Input Conditions			
t_R	Input signal rise time	2.5	ns
t_F	Input signal fall time	2.5	ns
Output Conditions			
C_{LOAD}	Output load capacitance	8.6	pF

Table 6-23. ISP Timing Requirements – 8-bit Packed SYNC – Interlaced Mode⁽⁴⁾

NO.	PARAMETER		1.15 V		1.0 V		UNIT
			MIN	MAX	MIN	MAX	
ISP3	$t_{c(pclk)}$	Cycle time ⁽¹⁾ , cam_pclk period	7.7		15.4		ns
ISP4	$t_{W(pclkH)}$	Typical pulse duration, cam_pclk high	0.5*P ⁽²⁾		0.5*P ⁽²⁾		ns
ISP4	$t_{W(pclkL)}$	Typical pulse duration, cam_pclk low	0.5*P ⁽²⁾		0.5*P ⁽²⁾		ns
	$t_{dc(pclk)}$	Duty cycle error, cam_pclk		385		769	ps
	$t_j(pclk)$	Cycle jitter ⁽³⁾ , cam_pclk		83		167	ps
ISP5	$t_{su(dV-pclkH)}$	Setup time, cam_d[11:0] valid before cam_pclk rising edge	1.08		2.27		ns
ISP6	$t_{h(pclkH-dV)}$	Hold time, cam_d[11:0] valid after cam_pclk rising edge	1.08		2.27		ns
ISP7	$t_{su(dV-vsH)}$	Setup time, cam_vs valid before cam_pclk rising edge	1.08		2.27		ns
ISP8	$t_{h(pclkH-vsV)}$	Hold time, cam_vs valid after cam_pclk rising edge	1.08		2.27		ns
ISP9	$t_{su(dV-hsH)}$	Setup time, cam_hs valid before cam_pclk rising edge	1.08		2.27		ns
ISP10	$t_{h(pclkH-hsV)}$	Hold time, cam_hs valid after cam_pclk rising edge	1.08		2.27		ns
ISP11	$t_{su(dV-hsH)}$	Setup time, cam_wen valid before cam_pclk rising edge	1.08		2.27		ns
ISP12	$t_{h(pclkH-hsV)}$	Hold time, cam_wen valid after cam_pclk rising edge	1.08		2.27		ns
ISP13	$t_{su(dV-flidH)}$	Setup time, cam_fld valid before cam_pclk rising edge	1.08		2.27		ns
ISP14	$t_{h(pclkH-flidV)}$	Hold time, cam_fld valid after cam_pclk rising edge	1.08		2.27		ns

- (1) Related with the input maximum frequency supported by the ISP module.
(2) P = cam_lclk period in ns.
(3) Maximum cycle jitter supported by cam_pclk input clock.
(4) The timing requirements are assured for the cycle jitter and duty cycle error conditions specified.

Table 6-24. ISP Switching Characteristics – 8-bit Packed SYNC – Interlaced Mode

NO.	PARAMETER		1.15 V		1.0 V		UNIT
			MIN	MAX	MIN	MAX	
ISP16	$t_{c(xclk)}$	Cycle time ⁽¹⁾ , cam_xclk period	4.6		4.6		ns
ISP2	$t_{W(xclkH)}$	Typical pulse duration, cam_xclk high	0.5*PO ⁽²⁾		0.5*PO ⁽²⁾		ns
ISP2	$t_{W(xclkL)}$	Typical pulse duration, cam_xclk low	0.5*PO ⁽²⁾		0.5*PO ⁽²⁾		ns
	$t_{dc(xclk)}$	Duty cycle error, cam_xclk		231		231	ps
	$t_j(xclk)$	Jitter standard deviation ⁽³⁾ , cam_xclk		67		67	ps
	$t_R(xclk)$	Rise time, cam_xclk		0.93		0.93	ns
	$t_F(xclk)$	Fall time, cam_xclk		0.93		0.93	ns

- (1) Related with the cam_xclk maximum and minimum frequencies programmable in the ISP module.
Warning: You must disable the camera sensor or the camera module to change the frequency configuration. For more information, see the *OMAP35xx ES2.0 Technical Reference Manual (TRM)* [literature number [SPRUJ98](#)].
(2) PO = cam_xclk period in ns.

(3) The jitter probability density can be approximated by a Gaussian function.

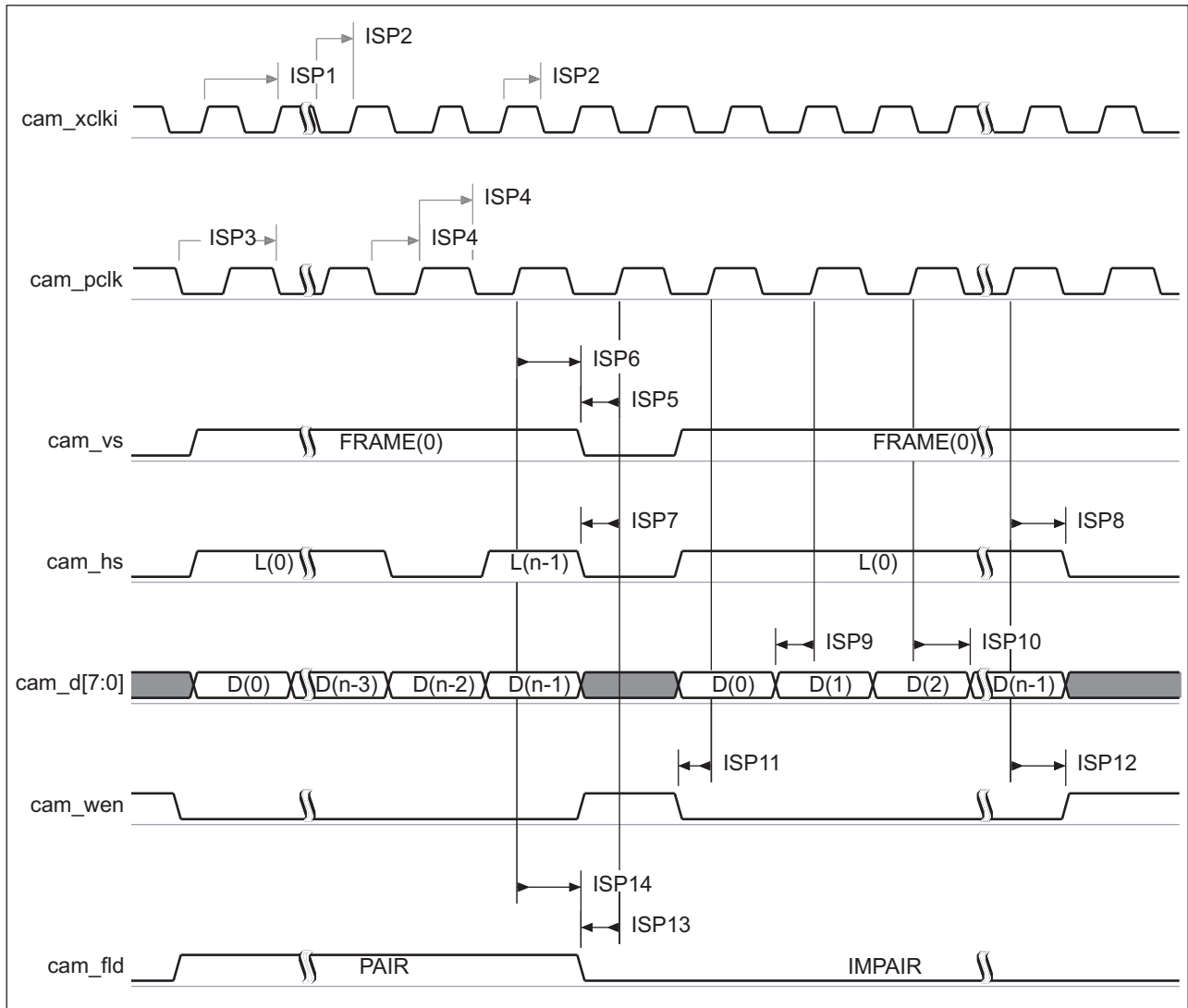

030-060

Figure 6-20. ISP – 8-bit Packed SYNC – Interlaced Mode⁽¹⁾⁽²⁾⁽³⁾⁽⁴⁾⁽⁵⁾

- (1) The polarity of cam_pclk, cam_fld, cam_vs, and cam_hs are configurable.
- (2) The image sensor must be connected to the lower data lines and the unused lines must be grounded. However, it is possible to shift the data to 0, 2, or 4 data internal lanes. The bit configurations are: cam_d[11:4] or cam_d[7:0] in 8-bit packed mode.
- (3) Optionally, the data write to memory can be qualified by the external cam_wen signal. The cam_wen signal can be used as an external memory write-enable signal. The data is stored to memory only if cam_hs, cam_vs, and cam_wen signals are asserted.
- (4) The camera module can pack 8-bit data into 16 bits. It doubles the maximum pixel clock. This mode can be particularly useful to transfer a YCbCr data stream or compressed stream to memory at very high speed.
- (5) In cam_xclki; I is equal to a or b.

6.5.1.1.2 ITU Mode

Table 6-26 and Table 6-27 assume testing over the recommended operating conditions and electrical characteristic conditions (see Figure 6-21).

Table 6-25. ISP Timing Conditions – ITU Mode

TIMING CONDITION PARAMETER		VALUE	UNIT
Input Conditions			
t_R	Input signal rise time	2.7	ns
t_F	Input signal fall time	2.7	ns
Output Conditions			
C_{LOAD}	Output load capacitance	8.6	pF

Table 6-26. ISP Timing Requirements – ITU Mode⁽⁴⁾

NO.	PARAMETER		1.15 V		1.0 V		UNIT
			MIN	MAX	MIN	MAX	
ISP17	$t_{c(pclk)}$	Cycle time ⁽¹⁾ , cam_pclk period	13.3		22.2		ns
ISP18	$t_{W(pclkH)}$	Typical pulse duration, cam_pclk high	0.5*P ⁽²⁾		0.5*P ⁽²⁾		ns
ISP18	$t_{W(pclkL)}$	Typical pulse duration, cam_pclk low	0.5*P ⁽²⁾		0.5*P ⁽²⁾		ns
	$t_{dc(pclk)}$	Duty cycle error, cam_pclk		667		1111	ps
	$t_{j(pclk)}$	Cycle jitter ⁽³⁾ , cam_pclk		133		200	ps
ISP23	$t_{su(dV-pclkH)}$	Setup time, cam_d[9:0] valid before cam_pclk rising edge	1.82		3.25		ns
ISP24	$t_{h(pclkH-dV)}$	Hold time, cam_d[9:0] valid after cam_pclk rising edge	1.82		3.25		ns

- (1) Related with the input maximum frequency supported by the ISP module.
- (2) P = cam_lclk period in ns.
- (3) Maximum cycle jitter supported by cam_lclk input clock.
- (4) The timing requirements are assured for the cycle jitter and duty cycle error conditions specified.

Table 6-27. ISP Switching Characteristics – ITU Mode

NO.	PARAMETER		1.15 V		1.0 V		UNIT
			MIN	MAX	MIN	MAX	
ISP15	$t_{c(xclk)}$	Cycle time ⁽¹⁾ , cam_xclk period	4.6		4.6		ns
ISP16	$t_{W(xclkH)}$	Typical pulse duration, cam_xclk high	0.5*PO ⁽²⁾		0.5*PO ⁽²⁾		ns
ISP16	$t_{W(xclkL)}$	Typical pulse duration, cam_xclk low	0.5*PO ⁽²⁾		0.5*PO ⁽²⁾		ns
	$t_{dc(xclk)}$	Duty cycle error, cam_xclk		231		231	ps
	$t_{j(xclk)}$	Jitter standard deviation ⁽³⁾ , cam_xclk		33		33	ps
	$t_{R(xclk)}$	Rise time, cam_xclk		0.93		0.93	ns
	$t_{F(xclk)}$	Fall time, cam_xclk		0.93		0.93	ns

- (1) Related with the cam_xclk maximum and minimum frequencies programmable in the ISP module.
Warning: The camera sensor or the camera module must be disabled to change the frequency configuration. For more information, see the *OMAP35xx ES2.0 Technical Reference Manual (TRM)* [literature number [SPRUF98](#)].
- (2) PO = cam_xclk period in ns
- (3) The jitter probability density can be approximated by a Gaussian function.

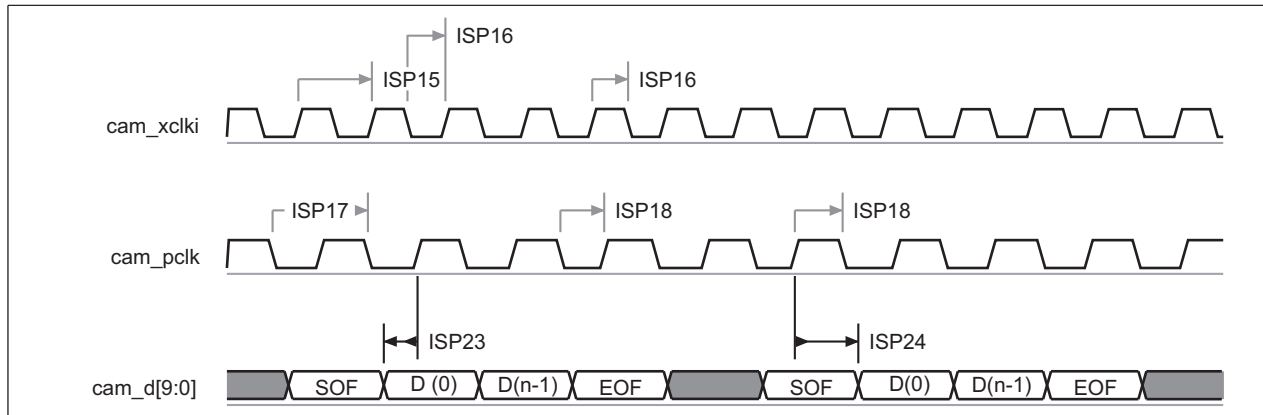

030-058

Figure 6-21. ISP – ITU Mode⁽¹⁾⁽²⁾

- (1) The unused lines must be grounded and the data bus must be connected to the lower data lines. It is possible to shift the data to 0, 2, or 4 data internal lanes. The different configurations are: cam_d[11:4] or cam_d[7:0] in 8-bit mode and cam_d[11:2] or cam_d[9:0] in 10-bit mode.
- (2) The parallel camera in ITU mode supports progressive camera modules.

6.5.2 Display Subsystem (DSS)

The display subsystem (DSS) provides the logic to display the video frame from external (SDRAM) or internal (SRAM) memory on an LCD panel or a TV set. The DSS integrates a display controller, a remote frame buffer module (RFBI), and a TV-out module. It can be used in two configurations:

- LCD display support in:
 - Bypass mode (RFBI module bypassed)
 - RFBI mode (through RFBI module)
- TV display support (not discussed in this document because of its analog IO signals)

The two display supports can be active at the same time.

6.5.2.1 LCD Display Support in Bypass Mode

Two types of LCD panel are supported:

- Thin film transistor (TFT) or active matrix technology
- Supertwisted nematic (STN) or passive matrix technology

Both configurations are discussed in the following paragraphs.

6.5.2.1.1 LCD Display in TFT Mode

Table 6-28 assumes testing over the recommended operating conditions (see Figure 6-22).

Table 6-28. LCD Display Interface Switching Characteristics in TFT Mode⁽³⁾⁽⁴⁾

NO.	PARAMETER		1.15 V		1.0 V		UNIT
			MIN	MAX	MIN	MAX	
DL0	$t_{d(PCLKA-HSYNCT)}$	Delay time, dss_pclk active edge to dss_hsync transition	–3.9	3.9	–4.6	4.6	ns
DL1	$t_{d(PCLKA-VSYNCT)}$	Delay time, dss_pclk active edge to dss_vsync transition	–3.9	3.9	–4.6	4.6	ns
DL2	$t_{d(PCLKA-ACBIASA)}$	Delay time, dss_pclk active edge to dss_acbias active level	–3.9	3.9	–4.6	4.6	ns
DL3	$t_{d(PCLKA-DATAV)}$	Delay time, dss_pclk active edge to dss_data bus valid	–3.9	3.9	–4.6	4.6	ns
DL4	$t_{c(PCLK)}$	Cycle time ⁽²⁾ , dss_pclk	13.5		13.5		ns
DL5	$t_{w(PCLK)}$	Pulse duration, dss_pclk low or high	0.45*P ⁽¹⁾	0.55*P ⁽¹⁾	0.45*P ⁽¹⁾	0.55*P ⁽¹⁾	ns

(1) P = dss_pclk period.

(2) The pixel clock frequency is software programmable via the pixel clock divider configuration from 1 to 255 division range in the DISPC_DIVISOR register.

(3) The capacitive load is equivalent to 25 pF at 1.15 V and 30 pF at 1.0 V.

(4) For more information, see the DSS chapter of the *OMAP35xx ES2.0 Technical Reference Manual (TRM)* [literature number TBD].

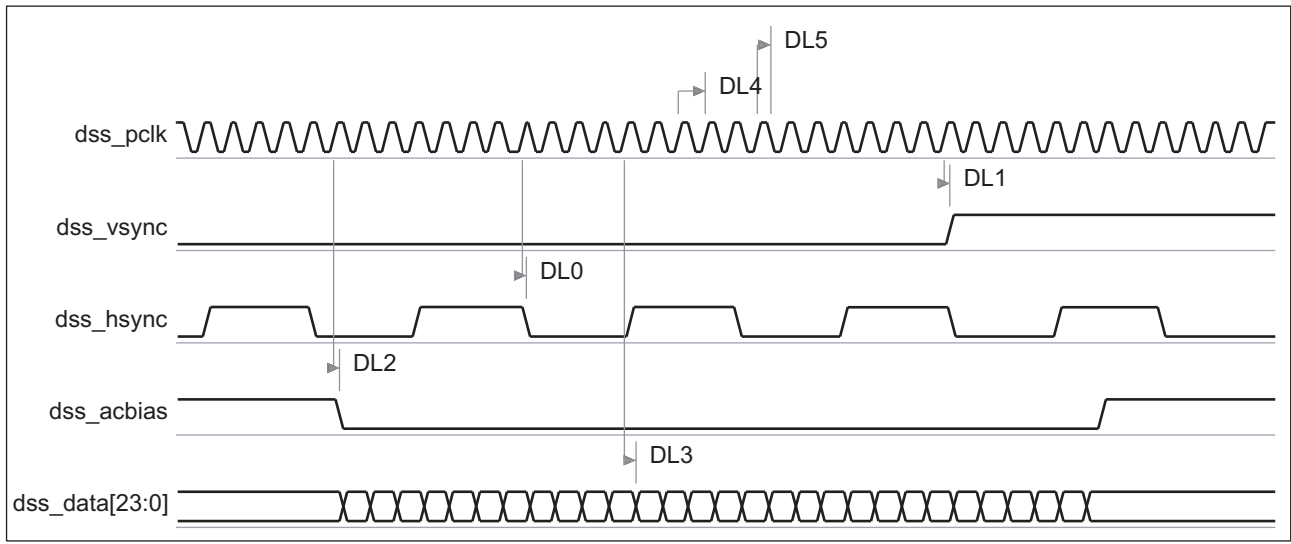

030-061

Figure 6-22. LCD Display in TFT Mode⁽¹⁾⁽²⁾⁽³⁾⁽⁴⁾

- (1) The pixel data bus depends on the use of 8-, 9-, 12-, 16-, 18-, or 24-bit per pixel data output pins.
- (2) The pixel clock frequency is programmable.
- (3) All timings not illustrated in the waveform are programmable by software, control signal polarity, and driven edge of dss_pclk.
- (4) For more information, see the DSS chapter of the *OMAP35xx ES2.0 Technical Reference Manual (TRM)* [literature number TBD].

6.5.2.1.2 LCD Display in STN Mode

Table 6-29 assumes testing over the recommended operating conditions (see Figure 6-23).

Table 6-29. LCD Display Interface Switching Characteristics in STN Mode⁽³⁾⁽⁴⁾⁽⁵⁾

NO.	PARAMETER		1.15 V		1.0 V		UNIT
			MIN	MAX	MIN	MAX	
DL3	$t_{d(PCLKA-DATAV)}$	Delay time, dss_pclk active edge to dss_data bus valid	-7	7	-7	7	ns
DL4	$t_{c(PCLK)}$	Cycle time ⁽²⁾ , dss_pclk	22.7		22.7		ns
DL5	$t_{w(PCLK)}$	Pulse duration, dss_pclk low or high	$0.45 \cdot P^{(1)}$	$0.55 \cdot P^{(1)}$	$0.45 \cdot P^{(1)}$	$0.55 \cdot P^{(1)}$	ns

- (1) P = dss_pclk period.
- (2) The pixel clock frequency is software programmable via the pixel clock divider configuration from 1 to 255 division range in the DISPC_DIVISOR register.
- (3) The DSS in STN mode is used with 4 or 8 pins only; unused pixel data bits always remain low.
- (4) The capacitive load is equivalent to 40 pF.
- (5) For more information, see the DSS chapter of the *OMAP35xx ES2.0 Technical Reference Manual (TRM)* [literature number TBD].

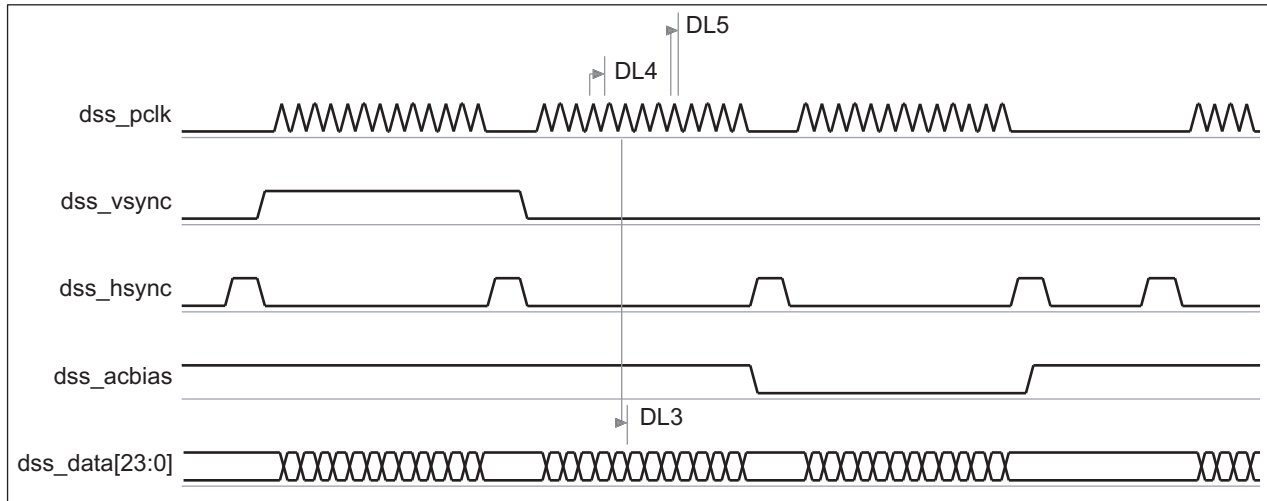

030-062

Figure 6-23. LCD Display in STN Mode⁽¹⁾⁽²⁾⁽³⁾⁽⁴⁾⁽⁵⁾

- (1) The pixel data bus depends on the use 4-, 8-, 12-, 16-, 18-, or 24-bit per pixel data output pins.
- (2) All timings not illustrated in the waveform are programmable by software, control signal polarity, and driven edge of dss_pclk.
- (3) dss_vsync width must be programmed to be as small as possible.
- (4) The pixel clock frequency is programmable.
- (5) For more information, see the DSS chapter of the *OMAP35xx ES2.0 Technical Reference Manual (TRM)* [literature number TBD].

6.5.2.2 LCD Display Support in RFBI Mode

Table 6-31 and Table 6-32 assume testing over the recommended operating conditions (see Figure 6-24 through Figure 6-26).

Table 6-30. LCD Timing Conditions – RFBI Mode

TIMING CONDITION PARAMETER		VALUE	UNIT
Input Conditions			
t _R	Input signal rise time	15	ns
t _F	Input signal fall time	15	ns
Output Conditions			
C _{LOAD}	Output load capacitance	30	pF

Table 6-31. LCD Display Interface Timing Requirements in RFBI Mode

NO.	PARAMETER		1.15 V		1.0 V		UNIT
			MIN	MAX	MIN	MAX	
DR16	t _{s(DAV-RDH)}	Setup time, rfb_da[15:0] valid to rfb_rd high	2.5	2.5 + I ⁽¹⁾	2.5	2.5 + I ⁽¹⁾	ns
DR17	t _{h(RDH-DAIV)}	Hold time, rfb_rd high to rfb_da[15:0] invalid	2.5	2.5 + I ⁽¹⁾	2.5	2.5 + I ⁽¹⁾	ns

(1) I = ((REOffTime – AccessTime) * (TimeParaGranularity + 1) * L4CLK

Table 6-32. LCD Display Interface Switching Characteristics in RFBI Mode

NO.	PARAMETER		1.15 V		1.0 V		UNIT
			MIN	MAX	MIN	MAX	
DR2	$t_{w(rfbi_wrH)}$	Pulse duration, rfb_i_wr high	A ⁽¹⁾		A ⁽¹⁾		ns
DR3	$t_{w(rfbi_wrL)}$	Pulse duration, rfb_i_wr low	B ⁽²⁾		B ⁽²⁾		ns
DR4	$t_{d(rfbi_a0-rfbi_wrL)}$	Delay time, rfb_i_a0 transition to rfb_i_wr low	A ⁽¹⁾ – 2.5	A ⁽¹⁾ + 2.5	A ⁽¹⁾ – 2.5	A ⁽¹⁾ + 2.5	ns
DR5	$t_{d(rfbi_a0-rfbi_wrH)}$	Delay time, rfb_i_a0 transition to rfb_i_wr high	C ⁽³⁾ – 2.5	C ⁽³⁾ + 2.5	C ⁽³⁾ – 2.5	C ⁽³⁾ + 2.5	ns
DR6	$t_{d(rfbi_csx-rfbi_wrL)}$	Delay time, rfb_i_csx ⁽¹⁰⁾ low to rfb_i_wr low	C ⁽³⁾ – 2.5	C ⁽³⁾ + 2.5	C ⁽³⁾ – 2.5	C ⁽³⁾ + 2.5	ns
DR7	$t_{d(rfbi_wrH-rfbi_csxH)}$	Delay time, rfb_i_wr high to rfb_i_csx ⁽¹⁰⁾ high	D ⁽⁴⁾ – 2.5	D ⁽⁴⁾ + 2.5	D ⁽⁴⁾ – 2.5	D ⁽⁴⁾ + 2.5	ns
DR8	$t_{d(rfbi_wrL-rfbi_daV)}$	Delay time, rfb_i_wr low to rfb_i_da[15:0] valid	B ⁽²⁾ – 2.5	B ⁽²⁾ + 2.5	B ⁽²⁾ – 2.5	B ⁽²⁾ + 2.5	ns
DR9	$t_{d(rfbi_a0H-rfbi_rdL)}$	Delay time, rfb_i_a0 high to rfb_i_rd low	F ⁽⁶⁾ – 2.5	F ⁽⁶⁾ + 2.5	F ⁽⁶⁾ – 2.5	F ⁽⁶⁾ + 2.5	ns
DR10	$t_{d(rfbi_csL-rfbi_rdL)}$	Delay time, rfb_i_csx ⁽¹⁰⁾ low to rfb_i_rd low	G ⁽⁷⁾ – 2.5	G ⁽⁷⁾ + 2.5	G ⁽⁷⁾ – 2.5	G ⁽⁷⁾ + 2.5	ns
DR12	$t_{w(rfbi_rdH)}$	Pulse duration, rfb_i_rd high	J ⁽⁹⁾		J ⁽⁹⁾		ns
DR13	$t_{w(rfbi_rdL)}$	Pulse duration, rfb_i_rd low	E ⁽⁵⁾		E ⁽⁵⁾		ns
DR14	$t_{d(rfbi_rdL-rfbi_csL)}$	Delay time, rfb_i_rd low to rfb_i_csx ⁽¹⁰⁾ low	H ⁽⁸⁾ – 2.5	H ⁽⁸⁾ + 2.5	H ⁽⁸⁾ – 2.5	H ⁽⁸⁾ + 2.5	ns
DR15	$t_{d(rfbi_rdH-rfbi_csH)}$	Delay time, rfb_i_rd high to rfb_i_csx ⁽¹⁰⁾ high	H ⁽⁸⁾ – 2.5	H ⁽⁸⁾ + 2.5	H ⁽⁸⁾ – 2.5	H ⁽⁸⁾ + 2.5	ns
	$t_{R(rfbi_wr)}$	Rise time, rfb_i_wr		15		15	ns
	$t_{F(rfbi_wr)}$	Fall time, rfb_i_wr		15		15	ns
	$t_{R(rfbi_a0)}$	Rise time, rfb_i_a0		15		15	ns
	$t_{F(rfbi_a0)}$	Fall time, rfb_i_a0		15		15	ns
	$t_{R(rfbi_csx)}$	Rise time, rfb_i_csx		15		15	ns
	$t_{F(rfbi_csx)}$	Fall time, rfb_i_csx		15		15	ns
	$t_{R(rfbi_da[15:0])}$	Rise time, rfb_i_da[15:0]		15		15	ns
	$t_{F(rfbi_da[15:0])}$	Fall time, rfb_i_da[15:0]		15		15	ns
	$t_{R(rfbi_rd)}$	Rise time, rfb_i_rd		15		15	ns
	$t_{F(rfbi_rd)}$	Fall time, rfb_i_rd		15		15	ns

- (1) A = (WEOnTime) * (TimeParaGranularity + 1) * L4CLK
- (2) B = (WEOffTime – WEOnTime) * (TimeParaGranularity + 1) * L4CLK
- (3) C = (WEOnTime – CSOnTime) * (TimeParaGranularity + 1) * L4CLK
- (4) D = (CSOffTime – WEOffTime) * (TimeParaGranularity + 1) * L4CLK
- (5) E = (REOffTime – REOnTime) * (TimeParaGranularity + 1) * L4CLK
- (6) F = REOnTime * (TimeParaGranularity + 1) * L4CLK
- (7) G = (REOnTime – CSOnTime) * (TimeParaGranularity + 1) * L4CLK
- (8) H = (CSOffTime – REOffTime) * (TimeParaGranularity + 1) * L4CLK
- (9) J = (REOnTime) * L4CLK
- (10) In RFBI_nCSx, x stands for 0 or 1.

PRODUCT PREVIEW

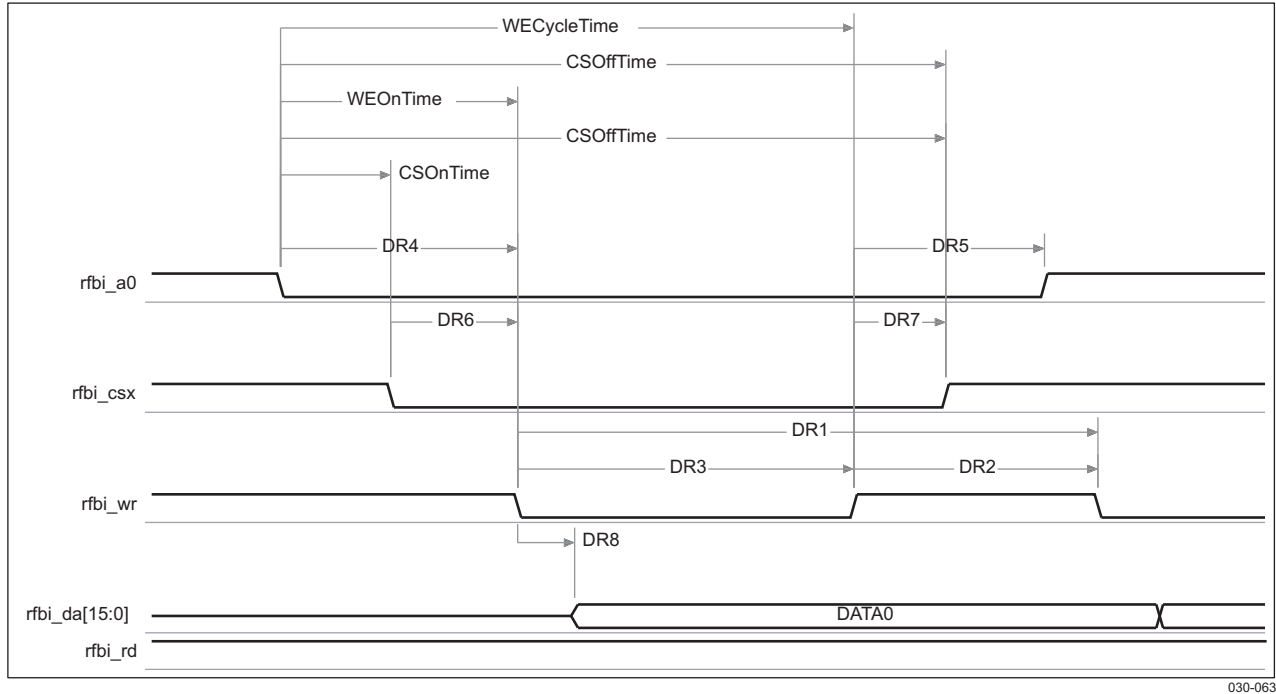

030-063

Figure 6-24. LCD Display Interface in RFBI Mode – Command / Data Write Mode⁽¹⁾⁽²⁾

- (1) In rfb_i_csx, x is equal to 0 or 1.
- (2) For more information, see the DSS chapter of the *OMAP35xx ES2.0 Technical Reference Manual (TRM)* [literature number TBD].

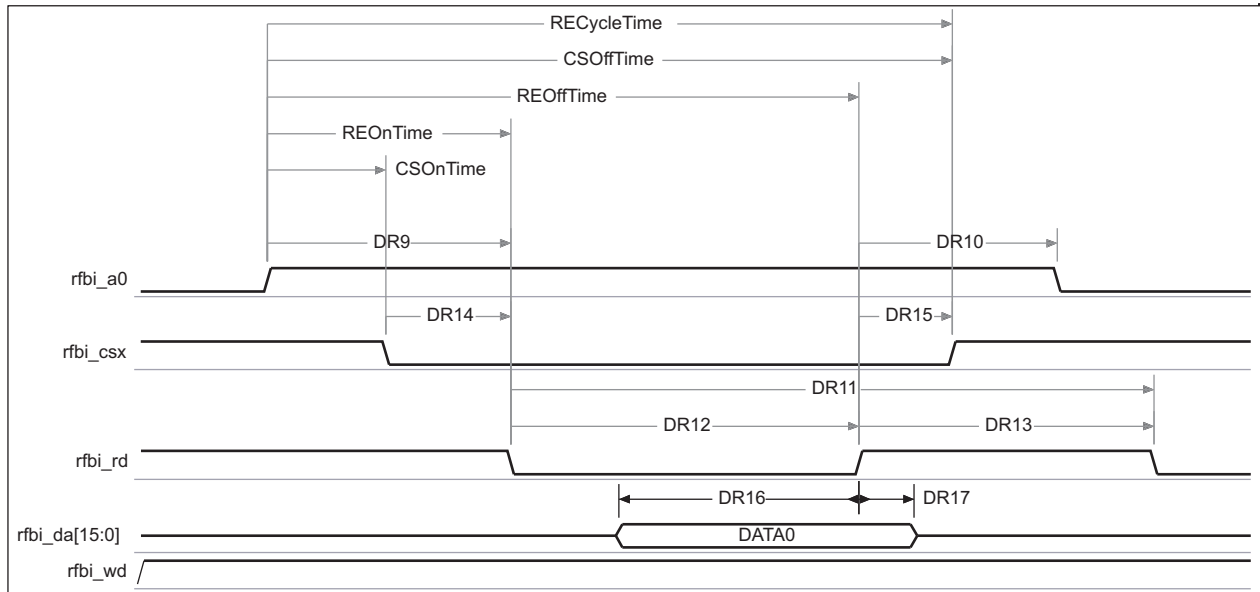

030-064

Figure 6-25. LCD Display Interface in RFBI Mode – Data Read Mode⁽¹⁾⁽²⁾

- (1) In rfb_i_csx, x is equal to 0 or 1.
- (2) For more information, see the DSS chapter of the *OMAP35xx ES2.0 Technical Reference Manual (TRM)* [literature number TBD].

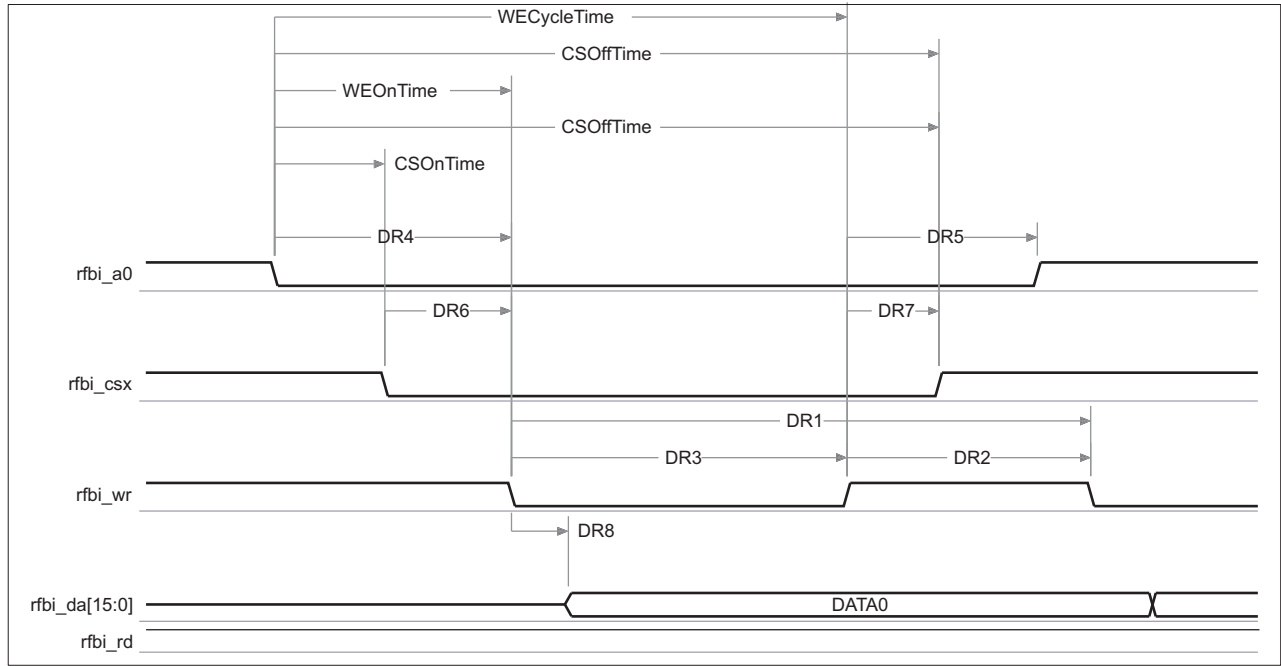

030-065

Figure 6-26. LCD Display Interface in RFBI Mode – Data Read-to-Write and Write-to-Read Modes⁽¹⁾⁽²⁾

- (1) In `rfbi_csx`, x is equal to 0 or 1.
- (2) For more information, see the DSS chapter of the *OMAP35xx ES2.0 Technical Reference Manual (TRM)* [literature number TBD].

6.6 Serial Communications Interfaces

6.6.1 Multichannel Buffered Serial Port (McBSP) Timing

There are five McBSP modules called McBSP1 through McBSP5. McBSP provides a full-duplex, direct serial interface between the OMAP3515/03 device and other devices in a system such as other application devices or codecs. It can accommodate a wide range of peripherals and clocked frame-oriented protocols (I2S, PCM, and TDM) due to its high level of versatility.

The McBSP1-5 modules may support two types of data transfer at the system level:

- The full-cycle mode, for which one clock period is used to transfer the data, generated on one edge and captured on the same edge (one clock period later).
- The half-cycle mode, for which one half clock period is used to transfer the data, generated on one edge and captured on the opposite edge (one half clock period later). Note that a new data is generated only every clock period, which secures the required hold time.

The interface clock (CLKX/CLKR) activation edge (data/frame sync capture and generation) has to be configured accordingly with the external peripheral (activation edge capability) and the type of data transfer required at the system level.

The OMAP3515/03 McBSP1-5 timing characteristics are described for both rising and falling activation edges. McBSP1 supports:

- 6-pin mode: dx and dr as data pins; clkx, clkr, fsx, and fsr as control pins.
- 4-pin mode: dx and dr as data pins; clkx and fsx pins as control pins. The clkx and fsx pins are internally looped back via software configuration, respectively, to the clkr and fsr internal signals for data receive.

McBSP2, 3, 4, and 5 support only the 4-pin mode.

The following sections describe the timing characteristics for applications in normal mode (that is, OMAP3515/03 McBSPx connected to one peripheral) and TDM applications in multipoint mode.

6.6.1.1 McBSP in Normal Mode

Table 6-33. McBSP Timing Conditions—Normal Mode

TIMING CONDITION PARAMETER		VALUE	UNIT
Input Conditions			
t_R	Input signal rise time	2	ns
t_F	Input signal fall time	2	ns
Output Conditions			
C_{LOAD}	Output load capacitance	10	pF

Table 6-34. McBSP Output Clock Pulse Duration

NO.	PARAMETER		1.15 V		1.0 V		UNIT
			MIN	MAX	MIN	MAX	
	$t_{W(CLKH)}$	Typical pulse duration, mcbbsp1_clkr / mcbbsp_x_clkx high ⁽²⁾	0.5*P ⁽¹⁾		0.5*P ⁽¹⁾		ns
	$t_{W(CLKL)}$	Typical pulse duration, mcbbsp1_clkr / mcbbsp_x_clkx low ⁽²⁾	0.5*P ⁽¹⁾		0.5*P ⁽¹⁾		ns
	$t_{dc(CLK)}$	Duty cycle error, mcbbsp1_clkr / mcbbsp_x_clkx ⁽²⁾	-0.75	0.75	-0.75	0.75	ns

(1) P = mcbbsp1_clkr / mcbbsp_x_clkx clock period.

(2) In mcbbsp_x, x identifies the McBSP number: 1, 2, 3, 4, or 5.

6.6.1.1.1 Receive Timing with Rising Edge as Activation Edge

Table 6-35 through Table 6-40 assume testing over the recommended operating conditions (see Figure 6-27 through Figure 6-28).

Table 6-35. McBSP1, 2, and 3 (Sets #2 and #3) Timing Requirements – Rising Edge and Receive Mode⁽¹⁾

NO.	PARAMETER			1.15 V		1.0 V		UNIT
				MIN	MAX	MIN	MAX	
B3	$t_{su}(DRV-CLKAE)$	Setup time, mcbsp _x _dr valid before mcbsp1_clk / mcbsp _x _clkx active edge	Master	3.5		7.7		ns
			Slave	3.7		7.9		ns
B4	$t_h(CLKAE-DRV)$	Hold time, mcbsp _x _dr valid after mcbsp1_clk / mcbsp _x _clkx active edge	Master	1		1		ns
			Slave	0.4		0.4		ns
B5	$t_{su}(FSV-CLKAE)$	Setup time, mcbsp1_fsr / mcbsp _x _fsx valid before mcbsp1_clk / mcbsp _x _clkx active edge		3.7		7.9		ns
B6	$t_h(CLKAE-FSV)$	Hold time, mcbsp1_fsr / mcbsp _x _fsx valid after mcbsp1_clk / mcbsp _x _clkx active edge		0.5		0.5		ns

Table 6-36. McBSP1, 2, and 3 (Sets #2 and #3) Switching Characteristics – Rising Edge and Receive Mode⁽¹⁾

NO.	PARAMETER			1.15 V		1.0 V		UNIT
				MIN	MAX	MIN	MAX	
B2	$t_d(CLKAE-FSV)$	Delay time, mcbsp1_clk / mcbsp _x _clkx active edge to mcbsp1_fsr / mcbsp _x _fsx valid	0.7	14.8	0.7	29.6	ns	

(1) In mcbsp_x, x identifies the McBSP number: 1, 2, or 3. Note that for the McBSP3, these timings concern only Set #2 (multiplexing mode on UART pins) and Set #3 (multiplexing mode on McBSP1 pins).

Table 6-37. McBSP4 (Set #1) Timing Requirements – Rising Edge and Receive Mode⁽¹⁾

NO.	PARAMETER			1.15 V		1.0 V		UNIT
				MIN	MAX	MIN	MAX	
B3	$t_{su}(DRV-CLKXAE)$	Setup time, mcbsp _x _dr valid before mcbsp _x _clkx active edge	Master	2.7		7.7		ns
			Slave	3.7		7.9		ns
B4	$t_h(CLKXAE-DRV)$	Hold time, mcbsp _x _dr valid after mcbsp _x _clkx active edge	Master	1		1		ns
			Slave	0.4		0.4		ns
B5	$t_{su}(FSXV-CLKXAE)$	Setup time mcbsp _x _fsx valid before mcbsp _x _clkx active edge		3.7		7.9		ns
B6	$t_h(CLKXAE-FSXV)$	Hold Time mcbsp _x _fsx valid after mcbsp _x _clkx active edge		0.5		0.5		ns

Table 6-38. McBSP4 (Set #1) Switching Characteristics – Rising Edge and Receive Mode⁽¹⁾

NO.	PARAMETER			1.15 V		1.0 V		UNIT
				MIN	MAX	MIN	MAX	
B2	$t_d(CLKXAE-FSXV)$	Delay time, mcbsp _x _clkx active edge to mcbsp _x _fsx valid	0.7	16.6	0.7	33.1	ns	

(1) In mcbsp_x, x identifies the McBSP number: 4. Note that for the McBSP4, these timings concern only Set #1: multiplexing mode by default. The McBSP4 is also multiplexed on GPMC pins (Set #2): the corresponding timings are specified in Table 6-39 and Table 6-40.

Table 6-39. McBSP3 (Set #1), 4 (Set #2), and 5 Timing Requirements – Rising Edge and Receive Mode⁽¹⁾

NO.	PARAMETER			1.15 V		1.0 V		UNIT
				MIN	MAX	MIN	MAX	
B3	$t_{su}(DRV-CLKXAE)$	Setup time, mcbsp _x _dr valid before mcbsp _x _clkx active edge	Master	5.6		12		ns
			Slave	5.8		12.2		ns
B4	$t_h(CLKXAE-DRV)$	Hold time, mcbsp _x _dr valid after mcbsp _x _clkx active edge	Master	1		1		ns
			Slave	0.4		0.4		ns

Table 6-39. McBSP3 (Set #1), 4 (Set #2), and 5 Timing Requirements – Rising Edge and Receive Mode⁽¹⁾
(continued)

NO.	PARAMETER		1.15 V		1.0 V		UNIT
			MIN	MAX	MIN	MAX	
B5	$t_{su}(FSXV-CLKXAE)$	Setup time, mcbspx_fsx valid before mcbspx_clkx active edge	5.8		12.2		ns
B6	$t_h(CLKXAE-FSXV)$	Hold time, mcbspx_fsx valid after mcbspx_clkx active edge	0.5		0.5		ns

Table 6-40. McBSP3 (Set #1), 4 (Set #2), and 5 Switching Requirements – Rising Edge and Receive Mode⁽¹⁾

NO.	PARAMETER		1.15 V		1.0 V		UNIT
			MIN	MAX	MIN	MAX	
B2	$t_d(CLKXAE-FSXV)$	Delay time, mcbspx_clkx active edge to mcbspx_fsx valid	0.7	22.2	0.7	44.4	ns

(1) In mcbspx, x identifies the McBSP number: 3, 4, or 5. Note that for the McBSP3, these timings concern only Set #1: multiplexing mode by default. The McBSP3 is also multiplexed on UART pins (Set #2) and on McBSP1 pins (Set #3): the corresponding timings are specified in [Table 6-37](#) and [Table 6-38](#).
For the McBSP4, these timings concern only Set #2 (multiplexing mode on GPMC pins).

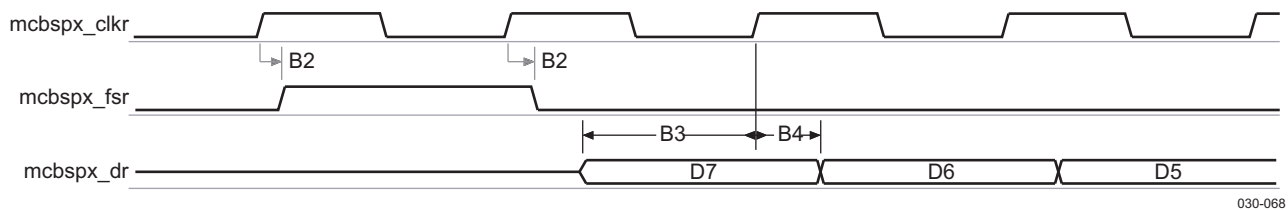

Figure 6-27. McBSP Rising Edge Receive Timing in Master Mode

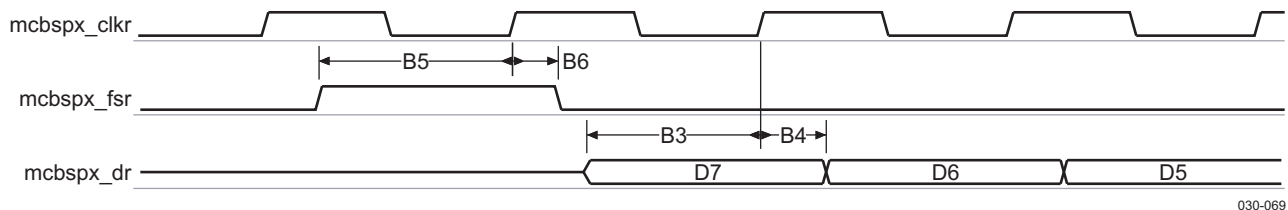

Figure 6-28. McBSP Rising Edge Receive Timing in Slave Mode

6.6.1.1.2 Transmit Timing with Rising Edge as Activation Edge

[Table 6-41](#) through [Table 6-46](#) assume testing over the recommended operating conditions (see [Figure 6-29](#) and [Figure 6-30](#)).

Table 6-41. McBSP1, 2, and 3 (Sets #2 and #3) Timing Requirements – Rising Edge and Transmit Mode⁽¹⁾

NO.	PARAMETER		1.15 V		1.0 V		UNIT
			MIN	MAX	MIN	MAX	
B5	$t_{su}(FSXV-CLKXAE)$	Setup time, mcbspx_fsx valid before mcbspx_clkx active edge	3.7		7.9		ns
B6	$t_h(CLKXAE-FSXV)$	Hold time, mcbspx_fsx valid after mcbspx_clkx active edge	0.5		0.5		ns

Table 6-42. McBSP1, 2, and 3 (Sets #2 and #3) Switching Characteristics – Rising Edge and Transmit Mode⁽¹⁾

NO.	PARAMETER		1.15 V		1.0 V		UNIT	
			MIN	MAX	MIN	MAX		
B2	$t_{d(CLKXAE-FSXV)}$	Delay time, mcbsp _x _clkx active edge to mcbsp _x _fsx valid	0.7	14.8	0.7	29.6	ns	
B8	$t_{d(CLKXAE-DXV)}$	Delay time, mcbsp _x _clkx active edge to mcbsp _x _dx valid	Master	0.6	14.8	0.6	29.6	ns
			Slave	0.6	14.8	0.6	29.6	ns

(1) In mcbsp_x, x identifies the McBSP number: 1, 2, or 3. Note that for the McBSP3, these timings concern only Set #2 (multiplexing mode on UART pins) and Set #3 (multiplexing mode on McBSP1 pins).

Table 6-43. McBSP4 (Set #1) Timing Requirements – Rising Edge and Transmit Mode⁽¹⁾

NO.	PARAMETER		1.15 V		1.0 V		UNIT
			MIN	MAX	MIN	MAX	
B5	$t_{su(FSXV-CLKXAE)}$	Setup time, mcbsp _x _fsx valid before mcbsp _x _clkx active edge	3.7		7.9		ns
B6	$t_h(CLKXAE-FSXV)$	Hold time, mcbsp _x _fsx valid after mcbsp _x _clkx active edge	0.5		0.5		ns

Table 6-44. McBSP4 (Set #1) Switching Characteristics – Rising Edge and Transmit Mode⁽¹⁾

NO.	PARAMETER		1.15 V		1.0 V		UNIT	
			MIN	MAX	MIN	MAX		
B2	$t_{d(CLKXAE-FSXV)}$	Delay time, mcbsp _x _clkx active edge to mcbsp _x _fsx valid	0.7	16.6	0.7	33.1	ns	
B8	$t_{d(CLKXAE-DXV)}$	Delay time, mcbsp _x _clkx active edge to mcbsp _x _dx valid	Master	0.6	16.6	0.6	33.1	ns
			Slave	0.6	17.3	0.6	33.1	ns

(1) In mcbsp_x, x identifies the McBSP number: 4. Note that for the McBSP4, these timings concern only Set #1: multiplexing mode by default. The McBSP4 is also multiplexed on GPMC pins (Set #2): the corresponding timings are specified in [Table 6-45](#).

Table 6-45. McBSP3 (Set #1), 4 (Set #2), and 5 Timing Requirements – Rising Edge and Transmit Mode⁽¹⁾

NO.	PARAMETER		1.15 V		1.0 V		UNIT
			MIN	MAX	MIN	MAX	
B5	$t_{su(FSXV-CLKXAE)}$	Setup time, mcbsp _x _fsx valid before mcbsp _x _clkx active edge	5.8		12.2		ns
B6	$t_h(CLKXAE-FSXV)$	Hold time, mcbsp _x _fsx valid after mcbsp _x _clkx active edge	0.5		0.5		ns

Table 6-46. McBSP 3 (Set #1), 4 (Set #2), and 5 Switching Requirements – Rising Edge and Transmit Mode⁽¹⁾

NO.	PARAMETER		1.15 V		1.0 V		UNIT	
			MIN	MAX	MIN	MAX		
B2	$t_{d(CLKXAE-FSXV)}$	Delay time, mcbsp _x _clkx active edge to mcbsp _x _fsx valid	0.7	22.2	0.7	44.4	ns	
B8	$t_{d(CLKXAE-DXV)}$	Delay time, mcbsp _x _clkx active edge to mcbsp _x _dx valid	Master	0.6	22.2	0.6	44.4	ns
			Slave	0.6	22.2	0.6	44.4	ns

(1) In mcbsp_x, x identifies the McBSP number: 3, 4 or 5. Note that for the McBSP3, these timings concern only Set #1: multiplexing mode by default. The McBSP3 is also multiplexed on UART pins (Set #2) and on McBSP1 pins (Set #3): the corresponding timings are specified in the table above. For the McBSP4, these timings concern only Set #2 (multiplexing mode on GPMC pins).

PRODUCT PREVIEW

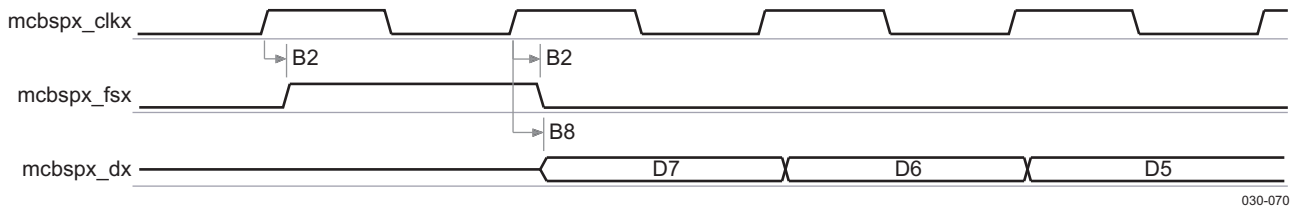

Figure 6-29. McBSP Rising Edge Transmit Timing in Master Mode

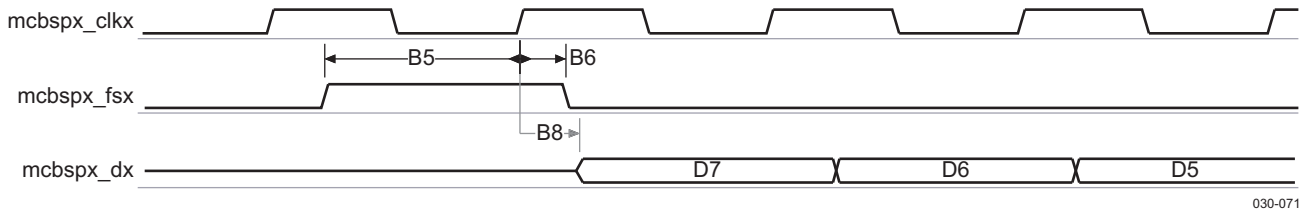

Figure 6-30. McBSP Rising Edge Transmit Timing in Slave Mode

6.6.1.1.3 Receive Timing with Falling Edge as Activation Edge

Table 6-47 through Table 6-52 assume testing over the recommended operating conditions (see Figure 6-31 and Figure 6-32).

Table 6-47. McBSP1, 2, and 3 (Sets #2 and #3) Timing Requirements – Falling Edge and Receive Mode⁽¹⁾

NO.	PARAMETER		1.15 V		1.0 V		UNIT
			MIN	MAX	MIN	MAX	
B3	$t_{su(DRV-CLKAE)}$	Setup time, mcbssp_dr valid before mcbssp1_clkr / mcbssp_clkx active edge	Master	3.5		7.7	ns
			Slave	3.7		7.9	ns
B4	$t_h(CLKAE-DRV)$	Hold time, mcbssp_dr valid after mcbssp1_clkr / mcbssp_clkx active edge	Master	1		1	ns
			Slave	0.4		0.4	ns
B5	$t_{su(FSV-CLKAE)}$	Setup time, mcbssp1_fsr / mcbssp_fsx valid before mcbssp1_clkr / mcbssp_clkx active edge		3.7		7.9	ns
B6	$t_h(CLKAE-FSV)$	Hold time, mcbssp1_fsr / mcbssp_fsx valid after mcbssp1_clkr / mcbssp_clkx active edge		0.5		0.5	ns

Table 6-48. McBSP1, 2, and 3 (Sets #2 and #3) Switching Characteristics – Falling Edge and Receive Mode⁽¹⁾

NO.	PARAMETER		1.15 V		1.0 V		UNIT
			MIN	MAX	MIN	MAX	
B2	$t_d(CLKAE-FSV)$	Delay time, mcbssp1_clkr / mcbssp_clkx active edge to mcbssp1_fsr / mcbssp_fsx valid	0.7	14.8	0.7	29.6	ns

(1) In mcbssp, x identifies the McBSP number: 1, 2, or 3. Note that for the McBSP3, these timings concern only Set #2 (multiplexing mode on UART pins) and Set #3 (multiplexing mode on McBSP1 pins).

Table 6-49. McBSP4 (Set #1) Timing Requirements – Falling Edge and Receive Mode⁽¹⁾

NO.	PARAMETER		1.15 V		1.0 V		UNIT
			MIN	MAX	MIN	MAX	
B3	$t_{su(DRV-CLKXAE)}$	Setup time, mcbssp_dr valid before mcbssp_clkx active edge	Master	2.7		7.7	ns
			Slave	3.7		7.9	ns
B4	$t_h(CLKXAE-DRV)$	Hold time, mcbssp_dr valid after mcbssp_clkx active edge	Master	1		1	ns
			Slave	0.4		0.4	ns

Table 6-49. McBSP4 (Set #1) Timing Requirements – Falling Edge and Receive Mode⁽¹⁾ (continued)

NO.	PARAMETER		1.15 V		1.0 V		UNIT
			MIN	MAX	MIN	MAX	
B5	$t_{su}(FSXV-CLKXAE)$	Setup time mcbsp _x _fsx valid before mcbsp _x _clkx active edge	3.7		7.9		ns
B6	$t_h(CLKXAE-FSXV)$	Hold time mcbsp _x _fsx valid after mcbsp _x _clkx active edge	0.5		0.5		ns

Table 6-50. McBSP4 (Set #1) Switching Characteristics – Falling Edge and Receive Mode⁽¹⁾

NO.	PARAMETER		1.15 V		1.0 V		UNIT
			MIN	MAX	MIN	MAX	
B2	$t_d(CLKXAE-FSXV)$	Delay time, mcbsp _x _clkx active edge to mcbsp _x _fsx valid	0.7	16.6	0.7	33.1	ns

(1) In mcbsp_x, x identifies the McBSP number: 4. Note that for the McBSP4, these timings concern only Set #1: multiplexing mode by default. The McBSP4 is also multiplexed on GPMC pins (Set #2): the corresponding timings are specified in Table 6-51.

Table 6-51. McBSP3 (Set #1), 4 (Set #2), and 5 Timing Requirements – Falling Edge and Receive Mode⁽¹⁾

NO.	PARAMETER			1.15 V		1.0 V		UNIT
				MIN	MAX	MIN	MAX	
B3	$t_{su}(DRV-CLKXAE)$	Setup time, mcbsp _x _dr valid before mcbsp _x _clkx active edge	Master	5.6		12		ns
			Slave	5.8		12.2		ns
B4	$t_h(CLKXAE-DRV)$	Hold time, mcbsp _x _dr valid after mcbsp _x _clkx active edge	Master	1		1		ns
			Slave	0.4		0.4		ns
B5	$t_{su}(FSXV-CLKXAE)$	Setup time, mcbsp _x _fsx valid before mcbsp _x _clkx active edge	5.8		12.2		ns	
B6	$t_h(CLKXAE-FSXV)$	Hold time, mcbsp _x _fsx valid after mcbsp _x _clkx active edge	0.5		0.5		ns	

Table 6-52. McBSP3 (Set #1), 4 (Set #2), and 5 Switching Requirements – Falling Edge and Receive Mode⁽¹⁾

NO.	PARAMETER		1.15 V		1.0 V		UNIT
			MIN	MAX	MIN	MAX	
B2	$t_d(CLKXAE-FSXV)$	Delay time, mcbsp _x _clkx active edge to mcbsp _x _fsx valid	0.7	22.2	0.7	44.4	ns

(1) In mcbsp_x, x identifies the McBSP number: 3, 4, or 5. Note that for the McBSP3, these timings concern only Set #1: multiplexing mode by default. The McBSP3 is also multiplexed on UART pins (Set #2) and on McBSP1 pins (Set #3): the corresponding timings are specified in the table above. For the McBSP4, these timings concern only Set #2 (multiplexing mode on GPMC pins).

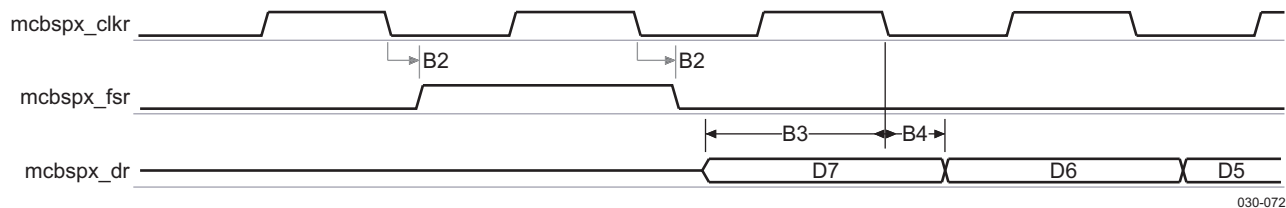
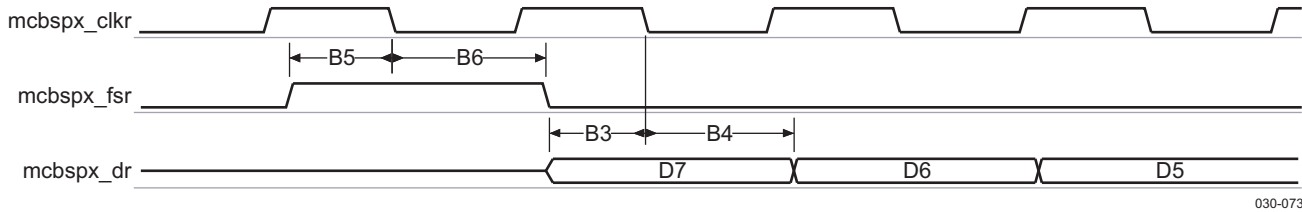

Figure 6-31. McBSP Falling Edge Receive Timing in Master Mode

030-072

PRODUCT PREVIEW



030-073

Figure 6-32. McBSP Falling Edge Receive Timing in Slave Mode

6.6.1.1.4 Transmit Timing with Falling Edge as Activation Edge

Table 6-53 through Table 6-58 assume testing over the recommended operating conditions (see Figure 6-33 and Figure 6-34).

Table 6-53. McBSP1, 2, and 3 (Sets #2 and #3) Timing Requirements – Falling Edge and Transmit Mode⁽¹⁾

NO.	PARAMETER		1.15 V		1.0 V		UNIT
			MIN	MAX	MIN	MAX	
B5	$t_{su}(FSXV-CLKXAE)$	Setup time, mcbsp_x_fsx valid before mcbsp_x_clkx active edge	3.7		7.9		ns
B6	$t_h(CLKXAE-FSXV)$	Hold time, mcbsp_x_fsx valid after mcbsp_x_clkx active edge	0.5		0.5		ns

Table 6-54. McBSP1, 2, and 3 (Sets #2 and #3) Switching Characteristics – Falling Edge and Transmit Mode⁽¹⁾

NO.	PARAMETER		1.15 V		1.0 V		UNIT	
			MIN	MAX	MIN	MAX		
B2	$t_d(CLKXAE-FSXV)$	Delay time, mcbsp_x_clkx active edge to mcbsp_x_fsx valid	0.7	14.8	0.7	29.6	ns	
B8	$t_d(CLKXAE-DXV)$	Delay time, mcbsp_x_clkx active edge to mcbsp_x_dx valid	Master	0.6	14.8	0.6	29.6	ns
			Slave	0.6	14.8	0.6	29.6	ns

(1) In mcbsp_x, x identifies the McBSP number: 1, 2, or 3. Note that for the McBSP3, these timings concern only Set #2 (multiplexing mode on UART pins) and Set #3 (multiplexing mode on McBSP1 pins).

Table 6-55. McBSP4 (Set #1) Timing Requirements – Falling Edge and Transmit Mode⁽¹⁾

NO.	PARAMETER		1.15 V		1.0 V		UNIT
			MIN	MAX	MIN	MAX	
B5	$t_{su}(FSXV-CLKXAE)$	Setup time, mcbsp_x_fsx valid before mcbsp_x_clkx active edge	3.7		7.9		ns
B6	$t_h(CLKXAE-FSXV)$	Hold time, mcbsp_x_fsx valid after mcbsp_x_clkx active edge	0.5		0.5		ns

Table 6-56. McBSP4 (Set #1) Switching Characteristics – Falling Edge and Transmit Mode⁽¹⁾

NO.	PARAMETER		1.15 V		1.0 V		UNIT	
			MIN	MAX	MIN	MAX		
B2	$t_d(CLKXAE-FSXV)$	Delay time, mcbsp_x_clkx active edge to mcbsp_x_fsx valid	0.7	16.6	0.7	33.1	ns	
B8	$t_d(CLKXAE-DXV)$	Delay time, mcbsp_x_clkx active edge to mcbsp_x_dx valid	Master	0.6	16.6	0.6	33.1	ns
			Slave	0.6	17.3	0.6	33.1	ns

(1) In mcbsp_x, x identifies the McBSP number: 4. Note that for the McBSP4, these timings concern only Set #1: multiplexing mode by default. The McBSP4 is also multiplexed on GPMC pins (Set #2): the corresponding timings are specified in Table 6-57.

PRODUCT PREVIEW

Table 6-57. McBSP3 (Set #1), 4 (Set #2), and 5 Timing Requirements – Falling Edge and Transmit Mode⁽¹⁾

NO.	PARAMETER		1.15 V		1.0 V		UNIT
			MIN	MAX	MIN	MAX	
B5	$t_{su}(FSXV-CLKXAE)$	Setup time, mcbspx_fsx valid before mcbspx_clkx active edge	5.8		12.2		ns
B6	$t_h(CLKXAE-FSXV)$	Hold time, mcbspx_fsx valid after mcbspx_clkx active edge	0.5		0.5		ns

Table 6-58. McBSP3 (Set #1), 4 (Set #2), and 5 Switching Requirements – Falling Edge and Transmit Mode⁽¹⁾

NO.	PARAMETER		1.15 V		1.0 V		UNIT	
			MIN	MAX	MIN	MAX		
B2	$t_d(CLKXAE-FSXV)$	Delay time, mcbspx_clkx active edge to mcbspx_fsx valid	0.7	22.2	0.7	44.4	ns	
B8	$t_d(CLKXAE-DXV)$	Delay time, mcbspx_clkx active edge to mcbspx_dx valid	Master	0.6	22.2	0.6	44.4	ns
			Slave	0.6	22.2	0.6	44.4	ns

(1) In mcbspx, x identifies the McBSP number: 3, 4, or 5. Note that for the McBSP3, these timings concern only Set #1: multiplexing mode by default. The McBSP3 is also multiplexed on UART pins (Set #2) and on McBSP1 pins (Set #3): the corresponding timings are specified in Table 6-57. For the McBSP4, these timings concern only Set #2 (multiplexing mode on GPMC pins).

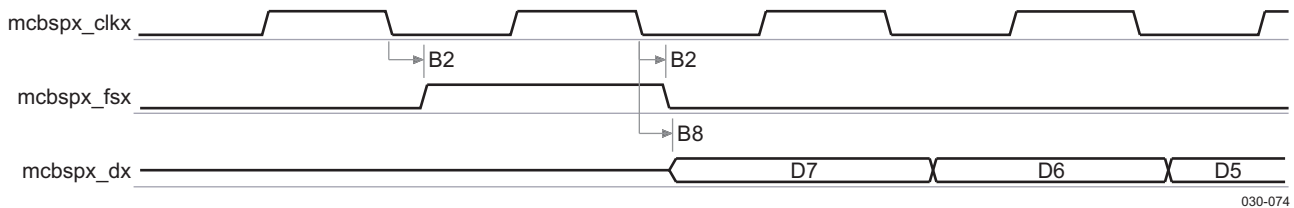

Figure 6-33. McBSP Falling Edge Transmit Timing in Master Mode

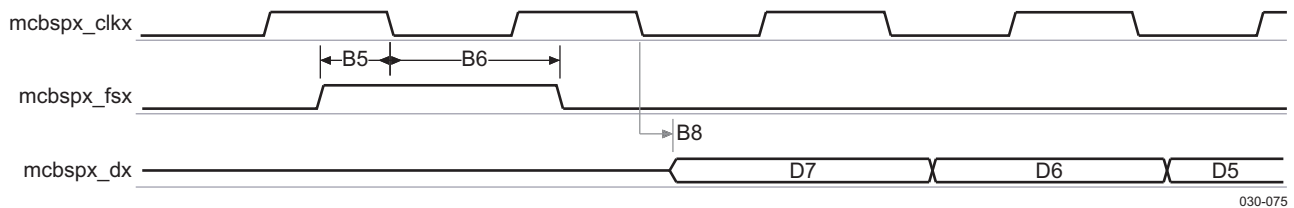

Figure 6-34. McBSP Falling Edge Transmit Timing in Slave Mode

6.6.1.2 McBSP in TDM—Multipoint Mode (McBSP3)

For TDM application in multipoint mode, OMAP3515/03 is considered as a slave. Table 6-60 and Table 6-61 assume testing over the operating conditions and electrical characteristic conditions described below.

Table 6-59. McBSP3 Timing Conditions—TDM in Multipoint Mode

TIMING CONDITION PARAMETER		VALUE		UNIT
		MIN	MAX	
Input Conditions				
t_R	Input signal rising time	1.0	8.5	ns
t_F	Input signal falling time	1.0	8.5	ns
Output Conditions				
C_{LOAD}	Output Load Capacitance		40	pF

Table 6-60. McBSP3 Timing Requirements—TDM in Multipoint Mode⁽²⁾

NO.	PARAMETER		1.15 V		1.0 V		UNIT
			MIN	MAX	MIN	MAX	
	$t_{W(CLKH)}$	Cycle Time, mcbbsp3_clkx	162.8		162.8		ns
	$t_{W(CLKH)}$	Typical Pulse duration, mcbbsp3_clkx high	0.5*P ⁽¹⁾		0.5*P ⁽¹⁾		ns
	$t_{W(CLKL)}$	Typical Pulse duration, mcbbsp3_clkx low	0.5*P ⁽¹⁾		0.5*P ⁽¹⁾		ns
	$t_{dc(CLK)}$	Duty cycle error, mcbbsp3_clkx	-8.14	8.14	-8.14	8.14	ns
B3 ⁽³⁾	$t_{su(DRV-CLKAE)}$	Setup time, mcbbsp3_dr valid before mcbbsp3_clkx active edge	9		9		ns
B4 ⁽³⁾	$t_h(CLKAE-DRV)$	Hold time, mcbbsp3_dr valid after mcbbsp3_clkx active edge	2.4		2.4		ns
B5 ⁽³⁾	$t_{su(FSV-CLKAE)}$	Setup time, mcbbsp3_fsx valid before mcbbsp3_clkx active edge	9		9		ns
B6 ⁽³⁾	$t_h(CLKAE-FSV)$	Hold time, mcbbsp3_fsx valid after mcbbsp3_clkx active edge	2.4		2.4		ns

(1) P = mcbbsp3_clkx period in ns

(2) For McBSP3, these timings concern only Set #3 (multiplexing mode in McBSP1 pins).

(3) See Section 6.6.1.1, *McBSP in Normal Mode* for corresponding figures.

Table 6-61. McBSP3 Switching Characteristics—TDM in Multipoint Mode⁽¹⁾

NO.	PARAMETER		1.15 V		1.0 V		UNIT
			MIN	MAX	MIN	MAX	
B8 ⁽²⁾	$t_d(CLKXAE-DXV)$	Delay time, mcbbsp3_clkx active edge to mcbbsp3_dx valid	0.6	16.8	0.6	29.6	ns

(1) For McBSP3, these timings concern only Set #3 (multiplexing mode in McBSP1 pins).

(2) See Section 6.6.1.1, *McBSP in Normal Mode* for corresponding figures.

6.6.2 Multichannel Serial Port Interface (McSPI) Timing

The multichannel SPI is a master/slave synchronous serial bus. The McSPI1 module supports up to four peripherals and the others (McSPI2, McSPI3, and McSPI4) support up to two peripherals. The following timings are applicable to the different configurations of McSPI in master/slave mode for any McSPI and any channel (n).

6.6.2.1 McSPI in Slave Mode

Table 6-62 and Table 6-63 assume testing over the recommended operating conditions (see Figure 6-35).

Table 6-62. McSPI Interface Timing Requirements – Slave Mode⁽¹⁾⁽⁴⁾

NO.	PARAMETER		1.15 V		1.0 V		UNIT
			MIN	MAX	MIN	MAX	
SS0	$t_c(CLK)$	Cycle time, mcspix_clk	41.7		83.3		ns
SS1	$t_w(CLK)$	Pulse duration, mcspix_clk high or low	0.45*P ⁽³⁾	0.55*P ⁽³⁾	0.45*P ⁽³⁾	0.55*P ⁽³⁾	ns
SS2	$t_{su}(SIMOV-CLKAE)$	Setup time, mcspix_simo valid before mcspix_clk active edge	4.2		9.5		ns
SS3	$t_h(SIMOV-CLKAE)$	Hold time, mcspix_simo valid after mcspix_clk active edge	4.6		9.9		ns
SS4	$t_{su}(CS0V-CLKFE)$	Setup time, mcspix_cs0 valid before mcspix_clk first edge	13.8		28.6		ns
SS5	$t_h(CS0I-CLKLE)$	Hold time, mcspix_cs0 invalid after mcspix_clk last edge	13.8		28.6		ns

Table 6-63. McSPI Interface Switching Requirements⁽²⁾⁽⁴⁾⁽⁵⁾⁽⁶⁾

NO.	PARAMETER		1.15 V		1.0 V		UNIT
			MIN	MAX	MIN	MAX	
SS6	$t_{d(CLKAE-SOMIV)}$	Delay time, mcspx_clk active edge to mcspx_somi shifted	1.8	15.9	3.2	31.7	ns
SS7	$t_{d(CS0AE-SOMIV)}$	Delay time, mcspx_cs0 active edge to mcspx_somi shifted		15.9		31.7	ns

- (1) The input timing requirements are given by considering a rise time and a fall time of 4 ns.
- (2) The capacitive load is equivalent to 20 pF.
- (3) P = mcspx_clk clock period
- (4) In mcspx, x is equal to 1, 2, 3, or 4.
- (5) The polarity of mcspx_clk and the active edge (rising or falling) on which mcspx_simo is driven and mcspx_somi is latched is all software configurable.
- (6) This timing applies to all configurations regardless of mcspx_clk polarity and which clock edges are used to drive output data and capture input data.

PRODUCT PREVIEW

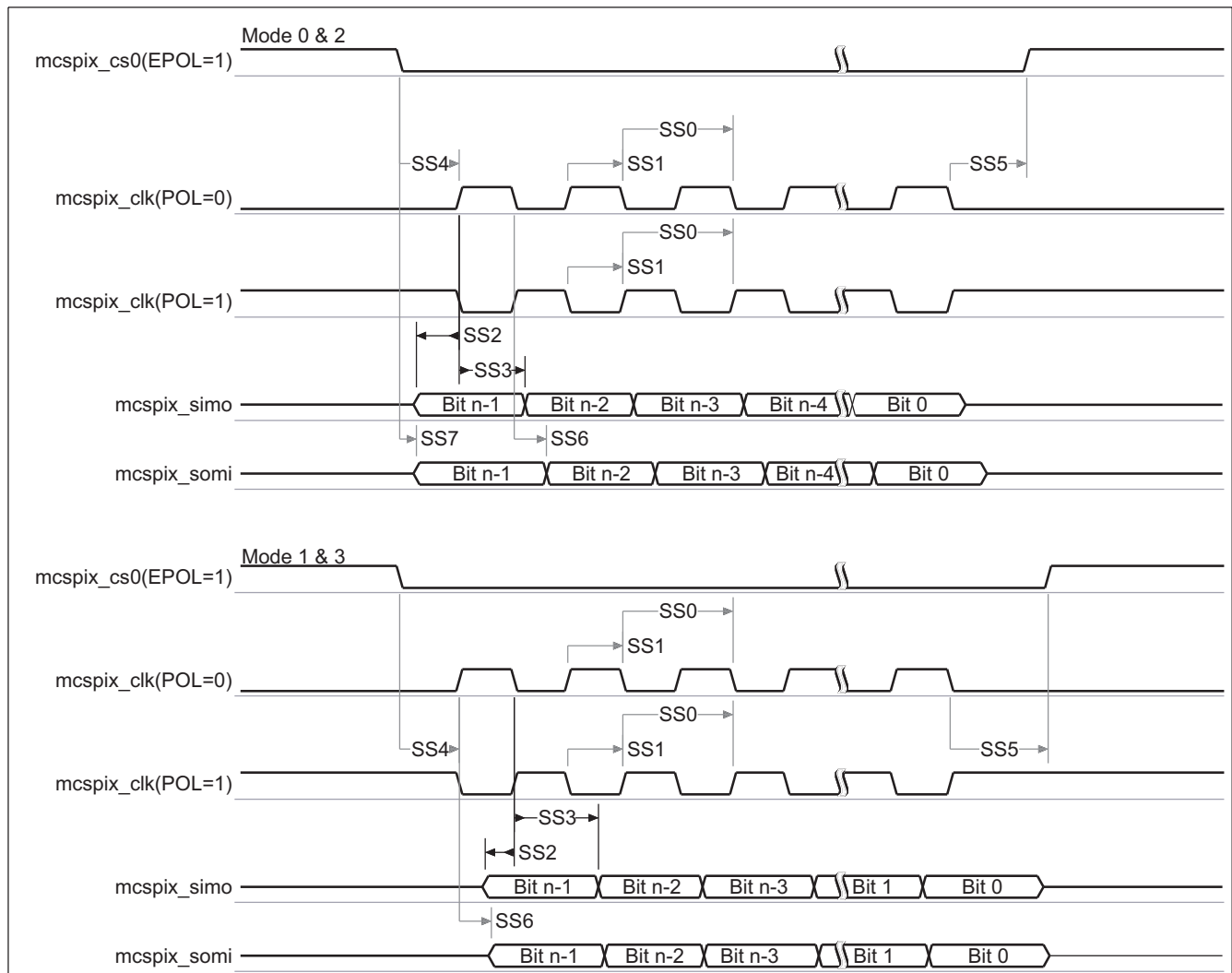

030-076

Figure 6-35. McSPI Interface – Transmit and Receive in Slave Mode⁽¹⁾⁽²⁾

- (1) The active clock edge (rising or falling) on which mcspx_somi is driven and mcspx_simo data is latched is software configurable with the bit MSPI_CHCONFx[0] = PHA and the bit MSPI_CHCONFx[1] = POL.
- (2) The polarity of mcspx_csi is software configurable with the bit MSPI_CHCONFx[6] = EPOL In mcspx, x is equal to 1, 2, 3, or 4.

6.6.2.2 McSPI in Master Mode

Table 6-64 and Table 6-65 assume testing over the recommended operating conditions (see Figure 6-36).

Table 6-64. McSPI1, 2, and 4 Interface Timing Requirements – Master Mode⁽¹⁾⁽⁴⁾

NO.	PARAMETER		1.15 V		1.0 V		UNIT
			MIN	MAX	MIN	MAX	
SM2	$t_{su}(SOMIV-CLKAE)$	Setup time, mcspix_somi valid before mcspix_clk active edge	1.1		1.5		ns
SM3	$t_h(SOMIV-CLKAE)$	Hold time, mcspix_somi valid after mcspix_clk active edge	1.9		2.8		ns

Table 6-65. McSPI1, 2, and 4 Interface Switching Characteristics – Master Mode⁽²⁾⁽⁴⁾⁽⁵⁾

NO.	PARAMETER		1.15 V		1.0 V		UNIT
			MIN	MAX	MIN	MAX	
SM0	$t_c(CLK)$	Cycle time, mcspix_clk	20.8		41.7		ns
SM1	$t_w(CLK)$	Pulse duration, mcspix_clk high or low	$0.45 \cdot P^{(3)}$	$0.55 \cdot P^{(3)}$	$0.45 \cdot P^{(3)}$	$0.55 \cdot P^{(3)}$	ns
SM4	$t_d(CLKAE-SIMOV)$	Delay time, mcspix_clk active edge to mcspix_simo shifted	-2.1	5	-2.1	11.3	ns
SM5	$t_d(CSnA-CLKFE)$	Delay time, mcspix_csi active to mcspix_clk first edge	Modes 1 and 3	$A^{(7)} - 3.1$		$A^{(7)} - 4.4$	ns
			Modes 0 and 2	$B^{(8)} - 3.1$		$B^{(8)} - 4.4$	ns
SM6	$t_d(CLKLE-CSnI)$	Delay time, mcspix_clk last edge to mcspix_csi inactive	Modes 1 and 3	$B^{(8)} - 3.1$		$B^{(8)} - 4.4$	ns
			Modes 0 and 2	$A^{(7)} - 3.1$		$A^{(7)} - 4.4$	ns
SM7	$t_d(CSnAE-SIMOV)$	Delay time, mcspix_csi active edge to mcspix_simo shifted		5.0		11.3	ns

PRODUCT PREVIEW

- (1) The input timing requirements are given by considering a rise time and a fall time of 4 ns.
- (2) Timings are given for a maximum load capacitance of 20 pF for spix_csn signals, 30 pF for spix_clk and spix_simo signals with x = 1 or 2, and 20 pF for spi4_clk and spi4_simo signals.
- (3) P = mcspix_clk clock period
- (4) In mcspix, x is equal to 1, 2, or 4. In mcspix_csn, n is equal to 0, 1, 2, or 3 for x equal to 1, n is equal to 0 or 1 for x equal to 2 and 4.
- (5) The polarity of mcspix_clk and the active edge (rising or falling) on which mcspix_simo is driven and mcspix_somi is latched is all software configurable.
- (6) This timing applies to all configurations regardless of mcspix_clk polarity and which clock edges are used to drive output data and capture input data.
- (7) Case P = 20.8 ns, A = (TCS+0.5)*P⁽³⁾ (TCS is a bit field of MSPI_CHCONFx[26:25] register). Case P > 20.8 ns, A = TCS*P⁽³⁾ (TCS is a bitfield of MSPI_CHCONFx[26:25] register). For more information, see the McSPI chapter of the *OMAP35xx ES2.0 Technical Reference Manual (TRM)* [literature number TBD].
- (8) B = TCS*P (TCS is a bit field of MSPI_CHCONFx[26:25] register). For more information, see the McSPI chapter of the *OMAP35xx ES2.0 Technical Reference Manual (TRM)* [literature number TBD].

Table 6-66 and Table 6-67 assume testing over the recommended operating conditions (see Figure 6-36).

Table 6-66. McSPI 3 Interface Timing Requirements – Master Mode⁽¹⁾⁽⁴⁾

NO.	PARAMETER		1.15 V		1.0 V		UNIT
			MIN	MAX	MIN	MAX	
SM2	$t_{su}(SOMIV-CLKAE)$	Setup time, mcspi3_somi valid before mcspi3_clk active edge	1.5		4.3		ns
SM3	$t_h(SOMIV-CLKAE)$	Hold time, mcspi3_somi valid after mcspi3_clk active edge	2.8		5.9		ns

Table 6-67. McSPI3 Interface Switching Requirements – Master Mode⁽²⁾⁽⁴⁾⁽⁵⁾

NO.	PARAMETER		1.15 V		1.0 V		UNIT
			MIN	MAX	MIN	MAX	
SM0	$t_{c(CLK)}$	Cycle time, mcspix_clk	41.7		83.3		ns
SM1	$t_{w(CLK)}$	Pulse duration, mcspix_clk high or low	$0.45 * P^{(3)}$	$0.55 * P^{(3)}$	$0.45 * P^{(3)}$	$0.55 * P^{(3)}$	ns
SM4	$t_{d(CLKAE-SIMOV)}$	Delay time, mcspix_clk active edge to mcspix_simo shifted	-2.1	11.3	-5.3	23.6	ns
SM5	$t_{d(CSnA-CLKFE)}$	Delay time, mcspix_csi active to mcspix_clk first edge	Modes 1 and 3	$-4.4 + A^{(6)}$		$-10.1 + A^{(6)}$	ns
			Modes 0 and 2	$-4.4 + B^{(7)}$		$-10.1 + B^{(7)}$	ns
SM6	$t_{d(CLKLE-CSn)}$	Delay time, mcspix_clk last edge to mcspix_csi inactive	Modes 1 and 3	$-4.4 + A^{(6)}$		$-10.1 + A^{(6)}$	ns
			Modes 0 and 2	$-4.4 + B^{(7)}$		$-10.1 + B^{(7)}$	ns
SM7	$t_{d(CSnAE-SIMOV)}$	Delay time, mcspix_csi active edge to mcspix_simo shifted		11.3		23.6	ns

- (1) The input timing requirements are given by considering a rise time and a fall time of 4 ns.
- (2) The capacitive load is equivalent to 20 pF.
- (3) P = mcspi3_clk clock period
- (4) In mcspi3_csn, n is equal to 0 or 1. The polarity of mcspi3_clk and the active edge (rising or falling) on which mcspi3_simo is driven and mcspi3_somi is latched is all software configurable.
- (5) This timing applies to all configurations regardless of McSPI3_CLK polarity and which clock edges are used to drive output data and capture input data.
- (6) Case $P = 20.8$ ns, $A = (TCS + 0.5) * P^{(3)}$ (TCS is a bit field of MSPI_CHCONFx[26:25] register). Case $P > 20.8$ ns, $A = TCS * P^{(3)}$ (TCS is a bit field of MSPI_CHCONFx[26:25] register). For more information, see the McSPI chapter of the *OMAP35xx ES2.0 Technical Reference Manual (TRM)* [literature number TBD].
- (7) $B = TCS * P$ (TCS is a bit field of MSPI_CHCONFx[26:25] register). For more information, see the McSPI chapter of the *OMAP35xx ES2.0 Technical Reference Manual (TRM)* [literature number TBD].

PRODUCT PREVIEW

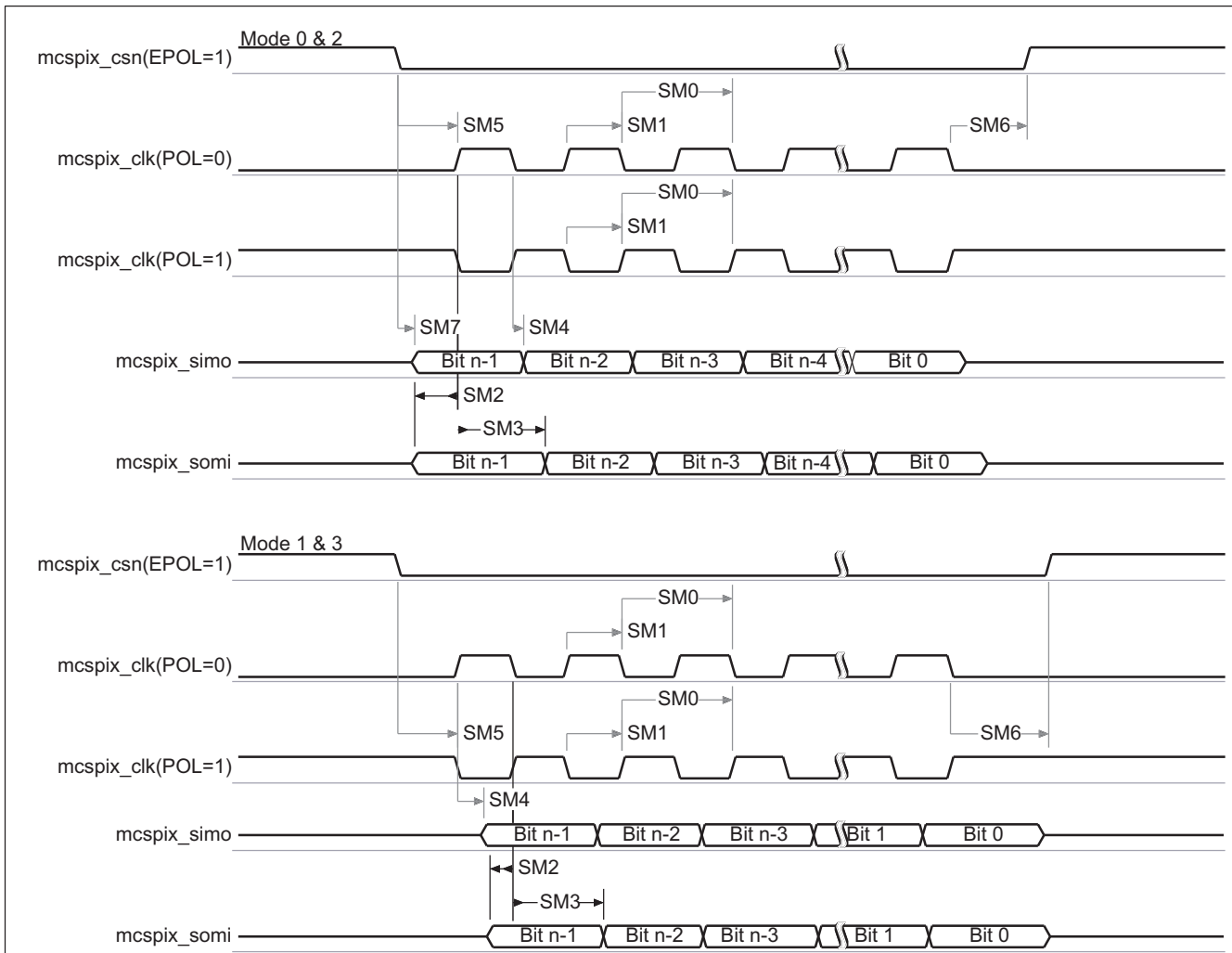

Figure 6-36. McSPI Interface – Transmit and Receive in Master Mode⁽¹⁾⁽²⁾⁽³⁾

- (1) The active clock edge (rising or falling) on which mcspx_simo is driven and mcspx_somi data is latched is software configurable with the bit MSPI_CHCONFx[0] = PHA and the bit MSPI_CHCONFx[1] = POL.
- (2) The polarity of mcspx_csi is software configurable with the bit MSPI_CHCONFx[6] = EPOL.
- (3) In mcspx, x is equal to 1. In mcspx_csn, n is equal to 0, 1, 2, or 3.

PRODUCT PREVIEW

6.6.3 Multiport Full-Speed Universal Serial Bus (USB) Interface

The OMAP3515/03 processor provides three USB ports working in full- and low-speed data transactions (up to 12Mbit/s).

Connected to either a serial link controller (TLL modes) or a serial PHY (PHY interface modes) it supports:

- 6-pin (Tx: Dat/Se0 or Tx: Dp/Dm) unidirectional mode
- 4-pin bidirectional mode
- 3-pin bidirectional mode

6.6.3.1 Multiport Full-Speed Universal Serial Bus (USB) – Unidirectional Standard 6-pin Mode

Table 6-69 and Table 6-70 assume testing over the recommended operating conditions (see Figure 6-37).

Table 6-68. Low-/Full-Speed USB Timing Conditions – Unidirectional Standard 6-pin Mode

TIMING CONDITION PARAMETER		VALUE	UNIT
Input Conditions			
t_R	Input signal rise time	2.0	ns
t_F	Input signal fall time	2.0	ns
Output Conditions			
C_{LOAD}	Output load capacitance	15.0	pF

Table 6-69. Low-/Full-Speed USB Timing Requirements – Unidirectional Standard 6-pin Mode

NO.	PARAMETER		1.15 V		1.0 V		UNIT
			MIN	MAX	MIN	MAX	
FSU1	$t_{d(Vp,Vm)}$	Time duration, mmx_rxdp and mmx_rxdm low together during transition		14.0		14.0	ns
FSU2	$t_{d(Vp,Vm)}$	Time duration, mmx_rxdp and mmx_rxdm high together during transition		8.0		8.0	ns
FSU3	$t_{d(RCVU0)}$	Time duration, mmx_rrxcv undefine during a single end 0 (mmx_rxdp and mmx_rxdm low together)		14.0		14.0	ns
FSU4	$t_{d(RCVU1)}$	Time duration, mmx_rxcv undefine during a single end 1 (mmx_rxdp and mmx_rxdm high together)		8.0		8.0	ns

(1) In mmx, x is equal to 0, 1, or 2.

Table 6-70. Low-/Full-Speed USB Switching Characteristics – Unidirectional Standard 6-pin Mode

NO.	PARAMETER		1.15 V		1.0 V		UNIT
			MIN	MAX	MIN	MAX	
FSU5	$t_{d(TXENL-DATV)}$	Delay time, mmx_txen_n low to mmx_txdat valid	81.8	84.8	81.8	84.8	ns
FSU6	$t_{d(TXENL-SE0V)}$	Delay time, mmx_txen_n low to mmx_txse0 valid	81.8	84.8	81.8	84.8	ns
FSU7	$t_s(DAT-SE0)$	Skew between mmx_txdat and mmx_txse0 transition		1.5		1.5	ns
FSU8	$t_{d(DATI-TXENH)}$	Delay time, mmx_txdat invalid to mmx_txen_n high	81.8		81.8		ns
FSU9	$t_{d(SE0I-TXENH)}$	Delay time, mmx_txse0 invalid to mmx_txen_n high	81.8		81.8		ns
	$t_{R(do)}$	Rise time, mmx_txen_n		4.0		4.0	ns
	$t_{F(do)}$	Fall time, mmx_txen_n		4.0		4.0	ns
	$t_{R(do)}$	Rise time, mmx_txdat		4.0		4.0	ns
	$t_{F(do)}$	Fall time, mmx_txdat		4.0		4.0	ns
	$t_{R(do)}$	Rise time, mmx_txse0		4.0		4.0	ns
	$t_{F(do)}$	Fall time, mmx_txse0		4.0		4.0	ns

(1) In mmx, x is equal to 0, 1, or 2.

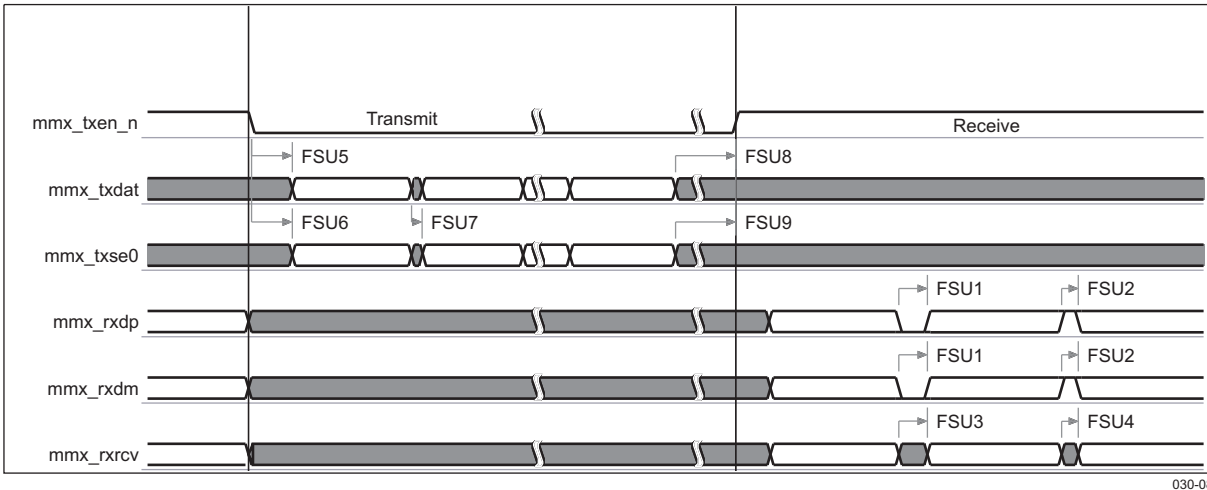

In mmx, x is equal to 0, 1, or 2.

Figure 6-37. Low-/Full-Speed USB – Unidirectional Standard 6-pin Mode

6.6.3.2 Multiport Full-Speed Universal Serial Bus (USB) – Bidirectional Standard 4-pin Mode

Table 6-72 and Table 6-73 assume testing over the recommended operating conditions (see Figure 6-38).

Table 6-71. Low-/Full-Speed USB Timing Conditions – Bidirectional Standard 4-pin Mode

TIMING CONDITION PARAMETER		VALUE	UNIT
Input Conditions			
t_R	Input signal rise time	2.0	ns
t_F	Input signal fall time	2.0	ns
Output Conditions			
C_{LOAD}	Output load capacitance	15.0	pF

Table 6-72. Low-/Full-Speed USB Timing Requirements – Bidirectional Standard 4-pin Mode

NO.	PARAMETER		1.15 V		1.0 V		UNIT
			MIN	MAX	MIN	MAX	
FSU10	$t_{d(DAT,SE0)}$	Time duration, mmx_txdat and mmx_txse0 low together during transition		14.0		14.0	ns
FSU11	$t_{d(DAT,SE0)}$	Time duration, mmx_txdat and mmx_txse0 high together during transition		8.0		8.0	ns
FSU12	$t_{d(RCVU0)}$	Time duration, mmx_rxcv undefine during a single end 0 (mmx_txdat and mmx_txse0 low together)		14.0		14.0	ns
FSU13	$t_{d(RCVU1)}$	Time duration, mmx_rxcv undefine during a single end 1 (mmx_txdat and mmx_txse0 high together)		8.0		8.0	ns

(1) In mmx, x is equal to 0, 1, or 2.

Table 6-73. Low-/Full-Speed USB Switching Characteristics – Bidirectional Standard 4-pin Mode

NO.	PARAMETER		1.15 V		1.0 V		UNIT
			MIN	MAX	MIN	MAX	
FSU14	$t_{d(TXENL-DATV)}$	Delay time, mmx_txen_n low to mmx_txdat valid	81.8	84.8	81.8	84.8	ns
FSU15	$t_{d(TXENL-SE0V)}$	Delay time, mmx_txen_n low to mmx_txse0 valid	81.8	84.8	81.8	84.8	ns
FSU16	$t_{s(DAT-SE0)}$	Skew between mmx_txdat and mmx_txse0 transition		1.5		1.5	ns
FSU17	$t_{d(DATV-TXENH)}$	Delay time, mmx_txdat invalid before mmx_txen_n high	81.8		81.8		ns

Table 6-73. Low-/Full-Speed USB Switching Characteristics – Bidirectional Standard 4-pin Mode (continued)

NO.	PARAMETER		1.15 V		1.0 V		UNIT
			MIN	MAX	MIN	MAX	
FSU18	$t_{d(SE0V-TXENH)}$	Delay time, mmx_txse0 invalid before mmx_txen_n high	81.8		81.8		ns
	$t_{R(txen)}$	Rise time, mmx_txen_n		4.0		4.0	ns
	$t_{F(txen)}$	Fall time, mmx_txen_n		4.0		4.0	ns
	$t_{R(dat)}$	Rise time, mmx_txdat		4.0		4.0	ns
	$t_{F(dat)}$	Fall time, mmx_txdat		4.0		4.0	ns
	$t_{R(se0)}$	Rise time, mmx_txse0		4.0		4.0	ns
	$t_{F(se0)}$	Fall time, mmx_txse0		4.0		4.0	ns

(1) In mmx, x is equal to 0, 1, or 2.

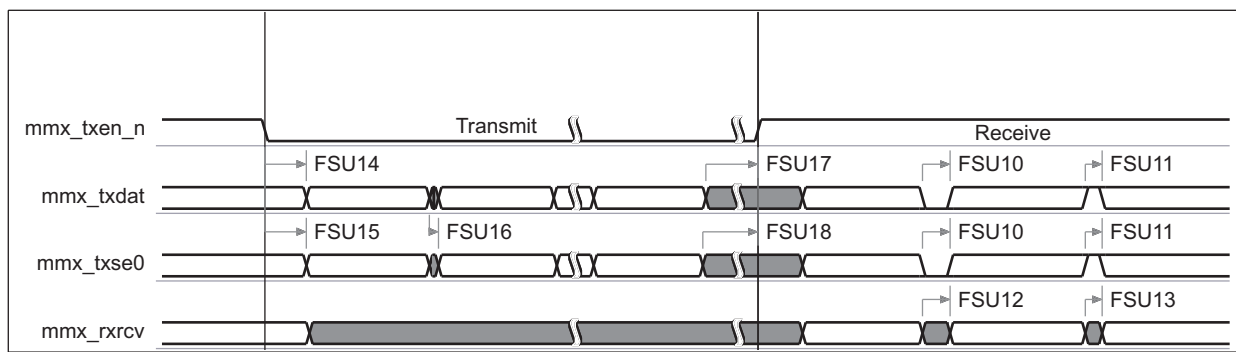

030-081

In mmx, x is equal to 0, 1, or 2.

Figure 6-38. Low-/Full-Speed USB – Bidirectional Standard 4-pin Mode

6.6.3.3 Multiport Full-Speed Universal Serial Bus (USB) – Bidirectional Standard 3-pin Mode

Table 6-75 and Table 6-76 assume testing over the recommended operating conditions below (see Figure 6-39).

Table 6-74. Low-/Full-Speed USB Timing Conditions – Bidirectional Standard 3-pin Mode

TIMING CONDITION PARAMETER		VALUE	UNIT
Input Conditions			
t_R	Input signal rise time	2.0	ns
t_F	Input signal fall time	2.0	ns
Output Conditions			
C_{LOAD}	Output load capacitance	15.0	pF

Table 6-75. Low-/Full-Speed USB Timing Requirements – Bidirectional Standard 3-pin Mode

NO.	PARAMETER		1.15 V		1.0 V		UNIT
			MIN	MAX	MIN	MAX	
FSU19	$t_{d(DAT,SE0)}$	Time duration, mmx_txdat and mmx_txse0 low together during transition		14.0		14.0	ns
FSU20	$t_{d(DAT,SE0)}$	Time duration, mmx_tsdats and mmx_txse0 high together during transition		8.0		8.0	ns

(1) In mmx, x is equal to 0, 1, or 2.

Table 6-76. Low-/Full-Speed USB Switching Characteristics – Bidirectional Standard 3-pin Mode

NO.	PARAMETER		1.15 V		1.0 V		UNIT
			MIN	MAX	MIN	MAX	
FSU21	$t_{d(TXENL-DATV)}$	Delay time, mmx_txen_n low to mmx_txdat valid	81.8	84.8	81.8	84.8	ns
FSU22	$t_{d(TXENL-SE0V)}$	Delay time, mmx_txen_n low to mmx_txse0 valid	81.8	84.8	81.8	84.8	ns
FSU23	$t_{s(DAT-SE0)}$	Skew between mmx_txdat and mmx_txse0 transition		1.5		1.5	ns
FSU24	$t_{d(DATI-TXENH)}$	Delay time, mmx_txdat invalid to mmx_txen_n high	81.8		81.8		ns
FSU25	$t_{d(SE0I-TXENH)}$	Delay time, mmx_txse0 invalid to mmx_txen_n high	81.8		81.8		ns
	$t_{R(do)}$	Rise time, mmx_txen_n		4.0		4.0	ns
	$t_{F(do)}$	Fall time, mmx_txen_n		4.0		4.0	ns
	$t_{R(do)}$	Rise time, mmx_txdat		4.0		4.0	ns
	$t_{F(do)}$	Fall time, mmx_txdat		4.0		4.0	ns
	$t_{R(do)}$	Rise time, mmx_txse0		4.0		4.0	ns
	$t_{F(do)}$	Fall time, mmx_txse0		4.0		4.0	ns

(1) In mmx, x is equal to 0, 1, or 2.

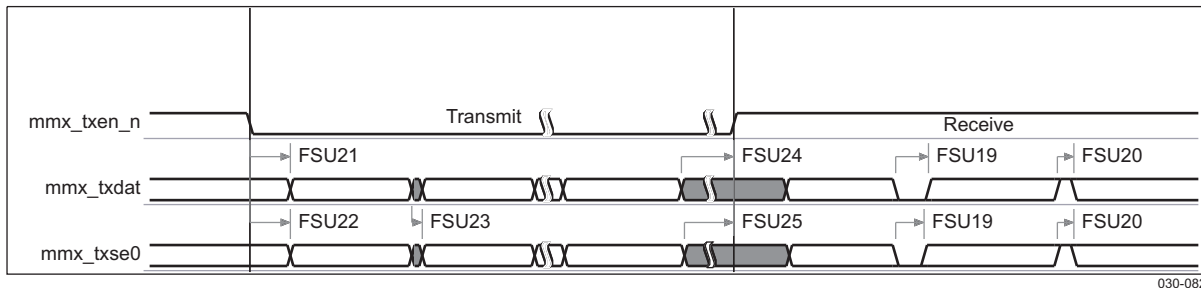

In mmx, x is equal to 0, 1, or 2.

Figure 6-39. Low-/Full-Speed USB – Bidirectional Standard 3-pin Mode

6.6.3.4 Multiport Full-Speed Universal Serial Bus (USB) – Unidirectional TLL 6-pin Mode

Table 6-78 and Table 6-79 assume testing over the recommended operating conditions (see Figure 6-40).

Table 6-77. Low-/Full-Speed USB Timing Conditions – Unidirectional TLL 6-pin Mode

TIMING CONDITION PARAMETER		VALUE	UNIT
Input Conditions			
t_R	Input signal rise time	2	ns
t_F	Input signal fall time	2	ns
Output Conditions			
C_{LOAD}	Output load capacitance	15	pF

Table 6-78. Low-/Full-Speed USB Timing Requirements – Unidirectional TLL 6-pin Mode

NO.	PARAMETER		1.15 V		1.0 V		UNIT
			MIN	MAX	MIN	MAX	
FSUT1	$t_{d(SE0,DAT)}$	Time duration, mmx_txse0 and mmx_txdat low together during transition		14		14	ns
FSUT2	$t_{d(SE0,DAT)}$	Time duration, mmx_txse0 and mmx_txdat high together during transition		8		8	ns

(1) In mmx, x is equal to 0, 1, or 2.

Table 6-79. Low-/Full-Speed USB Switching Characteristics – Unidirectional TLL 6-pin Mode

NO.	PARAMETER		1.15 V		1.0 V		UNIT
			MIN	MAX	MIN	MAX	
FSUT3	$t_{d(TXENH-DPV)}$	Delay time, mmx_txen_n high to mmx_rxdp valid	81.8	84.8	81.8	84.8	ns
FSUT4	$t_{d(TXENH-DMV)}$	Delay time, mmx_txen_n high to mmx_rxdm valid	81.8	84.8	81.8	84.8	ns
FSUT5	$t_{d(DPI-TXENL)}$	Delay time, mmx_rxdp invalid mmx_txen_n low	81.8		81.8		ns
FSUT6	$t_{d(DMI-TXENL)}$	Delay time, mmx_rxdm invalid mmx_txen_n low	81.8		81.8		ns
FSUT7	$t_{s(DP-DM)}$	Skew between mmx_rxdp and mmx_rxdm transition		1.5		1.5	ns
FSUT8	$t_{s(DP,DM-RCV)}$	Skew between mmx_rxdp, mmx_rxdm, and mmx_rxcv transition		1.5		1.5	ns
	$t_{R(rxrcv)}$	Rise time, mmx_rxcv		4		4	ns
	$t_{F(rxrcv)}$	Fall time, mmx_rxcv		4		4	ns
	$t_{R(dp)}$	Rise time, mmx_rxdp		4		4	ns
	$t_{F(dp)}$	Fall time, mmx_rxdp		4		4	ns
	$t_{R(dm)}$	Rise time, mmx_rxdm		4		4	ns
	$t_{F(dm)}$	Fall time, mmx_rxdm		4		4	ns

1. In mmx, x is equal to 0, 1, or 2.

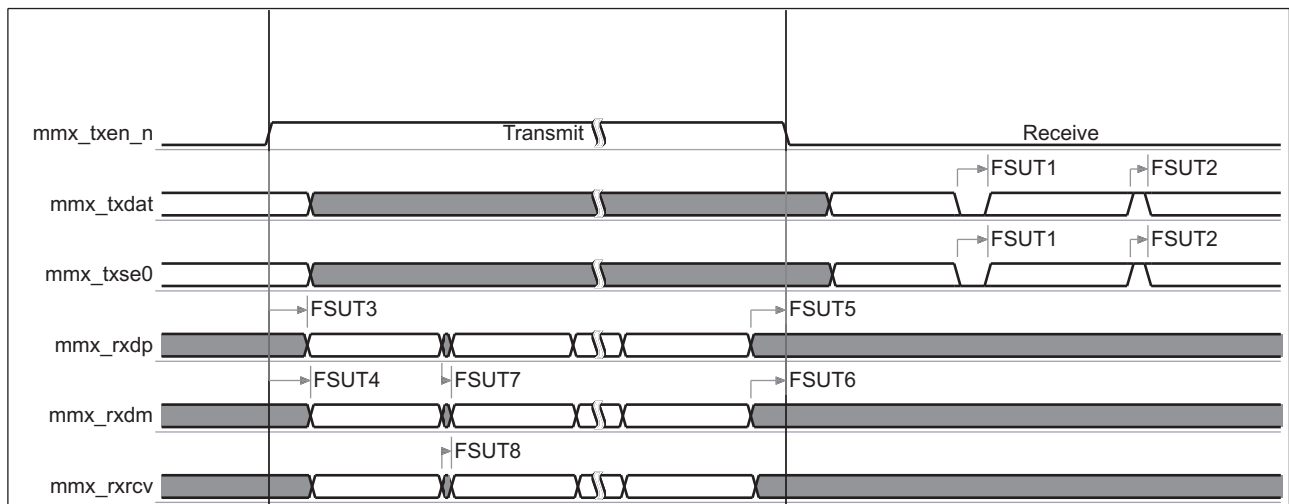

030-083

In mmx, x is equal to 0, 1, or 2.

Figure 6-40. Low-/Full-Speed USB – Unidirectional TLL 6-pin Mode

6.6.3.5 Multiport Full-Speed Universal Serial Bus (USB) – Bidirectional TLL 4-pin Mode

Table 6-81 and Table 6-82 assume testing over the recommended operating conditions (see Figure 6-41).

Table 6-80. Low-/Full-Speed USB Timing Conditions – Bidirectional TLL 4-pin Mode

TIMING CONDITION PARAMETER		VALUE	UNIT
Input Conditions			
t_R	Input signal rise time	2	ns
t_F	Input signal fall time	2	ns
Output Conditions			
C_{LOAD}	Output load capacitance	15	pF

Table 6-81. Low-/Full-Speed USB Timing Requirements – Bidirectional TLL 4-pin Mode

NO.	PARAMETER		1.15 V		1.0 V		UNIT
			MIN	MAX	MIN	MAX	
FSUT9	$t_{d(DAT,SE0)}$	Time duration, mmx_txdat and mmx_txse0 low together during transition		14		14	ns
FSUT10	$t_{d(DAT,SE0)}$	Time duration, mmx_tsdats and mmx_txse0 high together during transition		8		8	ns

(1) In mmx, x is equal to 0, 1, or 2.

Table 6-82. Low-/Full-Speed USB Switching Characteristics – Bidirectional TLL 4-pin Mode

NO.	PARAMETER		1.15 V		1.0 V		UNIT
			MIN	MAX	MIN	MAX	
FSUT11	$t_{d(TXENL-DATV)}$	Delay time, mmx_txen_n active to mmx_txdat valid	81.8	84.8	81.8	84.8	ns
FSUT12	$t_{d(TXENL-SE0V)}$	Delay time, mmx_txen_n active to mmx_txse0 valid	81.8	84.8	81.8	84.8	ns
FSUT13	$t_{s(DAT-SE0)}$	Skew between mmx_txdat and mmx_txse0 transition		1.5		1.5	ns
FSUT14	$t_{s(DP,DM-RCV)}$	Skew between mmx_rxdp, mmx_rxdm, and mmx_rxrcv transition		1.5		1.5	ns
FSUT15	$t_{d(DATI-TXENL)}$	Delay time, mmx_txse0 invalid to mmx_txen_n Low	81.8		81.8		ns
FSUT16	$t_{d(SE0I-TXENL)}$	Delay time, mmx_txdat invalid to mmx_txen_n Low	81.8		81.8		ns
	$t_{R(rcv)}$	Rise time, mmx_rxrcv		4		4	ns
	$t_{F(rcv)}$	Fall time, mmx_rxrcv		4		4	ns
	$t_{R(dat)}$	Rise time, mmx_txdat		4		4	ns
	$t_{F(dat)}$	Fall time, mmx_txdat		4		4	ns
	$t_{R(se0)}$	Rise time, mmx_txse0		4		4	ns
	$t_{F(se0)}$	Fall time, mmx_txse0		4		4	ns

(1) In mmx, x is equal to 0, 1, or 2.

PRODUCT PREVIEW

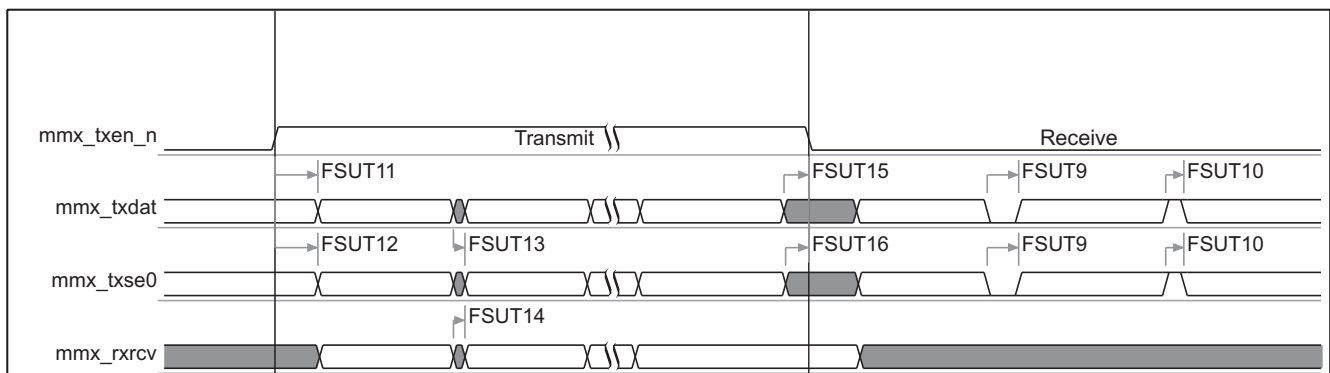

030-084

In mmx, x is equal to 0, 1, or 2.

Figure 6-41. Low-/Full-Speed USB – Bidirectional TLL 4-pin Mode

6.6.3.6 Multiport Full-Speed Universal Serial Bus (USB) – Bidirectional TLL 3-pin Mode

Table 6-84 and Table 6-85 assume testing over the recommended operating conditions (see Figure 6-42).

Table 6-83. Low-/Full-Speed USB Timing Conditions – Bidirectional TLL 3-pin Mode

TIMING CONDITION PARAMETER		VALUE	UNIT
Input Conditions			
t_R	Input signal rise time	2	ns
t_F	Input signal fall time	2	ns
Output Conditions			
C_{LOAD}	Output load capacitance	15	pF

Table 6-84. Low-/Full-Speed USB Timing Requirements – Bidirectional TLL 3-pin Mode

NO.	PARAMETER		1.15 V		1.0 V		UNIT
			MIN	MAX	MIN	MAX	
FSUT17	$t_d(DAT,SE0)$	Time duration, mmx_txd _{at} and mmx_txse ₀ low together during transition		14		14	ns
FSUT18	$t_d(DAT,SE0)$	Time duration, mmx_tsd _{at} and mmx_txse ₀ high together during transition		8		8	ns

(1) In mmx, x is equal to 0, 1, or 2.

Table 6-85. Low-/Full-Speed USB Switching Characteristics – Bidirectional TLL 3-pin Mode

NO.	PARAMETER		1.15 V		1.0 V		UNIT
			MIN	MAX	MIN	MAX	
FSUT19	$t_d(TXENH-DATV)$	Delay time, mmx_txen_n high to mmx_txd _{at} valid	81.8	84.8	81.8	84.8	ns
FSUT20	$t_d(TXENH-SE0V)$	Delay time, mmx_txen_n high to mmx_txse ₀ valid	81.8	84.8	81.8	84.8	ns
FSUT21	$t_s(DAT-SE0)$	Skew between mmx_txd _{at} and mmx_txse ₀ transition		1.5		1.5	ns
FSUT22	$t_d(DATI-TXENL)$	Delay time, mmx_txd _{at} invalid mmx_txen_n low	81.8		81.8		ns
FSUT23	$t_d(SE0I-TXENL)$	Delay time, mmx_txse ₀ invalid mmx_txen_n low	81.8		81.8		ns
	$t_R(dat)$	Rise time, mmx_txd _{at}		4		4	ns
	$t_F(dat)$	Fall time, mmx_txd _{at}		4		4	ns
	$t_R(se0)$	Rise time, mmx_txse ₀		4		4	ns
	$t_F(se0)$	Fall time, mmx_txse ₀		4		4	ns
	$t_R(do)$	Rise time, mmx_txse ₀		4		4	ns
	$t_F(do)$	Fall time, mmx_txse ₀		4		4	ns

(1) In mmx, x is equal to 0, 1, or 2.

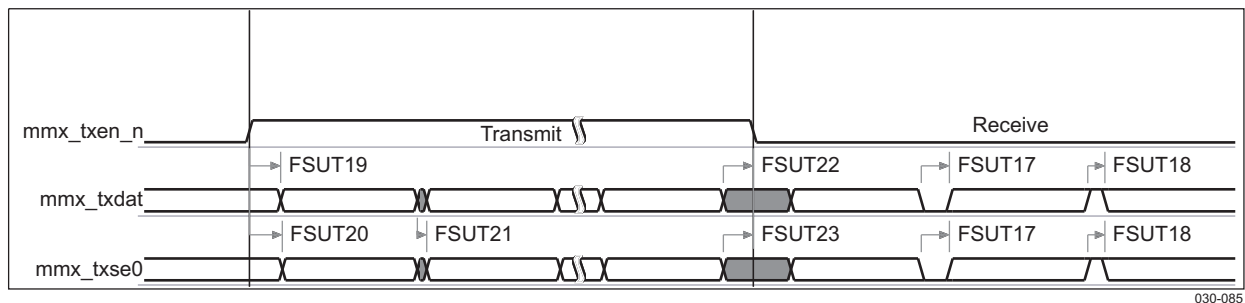

In mmx, x is equal to 0, 1, or 2.

Figure 6-42. Low-/Full-Speed USB – Bidirectional TLL 3-pin Mode

6.6.4 Multiport High-Speed Universal Serial Bus (USB) Timing

In addition to the full-speed USB controller, a high-speed (HS) USB OTG controller is instantiated inside OMAP3515/03. It allows high-speed transactions (up to 480 Mbit/s) on the USB ports 0, 1, 2, and 3.

- Port 0:
 - 12-bit slave mode (SDR)
- Port 1 and port 2:
 - 12-bit master mode (SDR)
 - 12-bit TLL master mode (SDR)
 - 8-bit TLL master mode (DDR)
- Port 3:
 - 12-bit TLL master mode (SDR)
 - 8-bit TLL master mode (DDR)

6.6.4.1 High-Speed Universal Serial Bus (USB) on Port 0 – 12-bit Slave Mode

Table 6-87 and Table 6-88 assume testing over the recommended operating conditions (see Figure 6-43).

Table 6-86. High-Speed USB Timing Conditions – 12-bit Slave Mode

TIMING CONDITION PARAMETER		VALUE	UNIT
Input Conditions			
t_r	Input Signal Rising Time	2.00	ns
t_f	Input Signal Falling Time	2.00	ns
Output Conditions			
C_{load}	Output Load Capacitance	3.50	pF

Table 6-87. High-Speed USB Timing Requirements – 12-bit Slave Mode⁽³⁾

NO.	PARAMETER		1.15 V		UNIT
			MIN	MAX	
HSU0	$f_p(\text{CLK})$	hsusb0_clk clock frequency ⁽¹⁾⁽²⁾		60.03	MHz
	$t_j(\text{CLK})$	Cycle Jitter ⁽²⁾ , hsub0_clk		500.00	ps
HSU3	$t_s(\text{DIRV-CLKH})$	Setup time, hsub0_dir valid before hsub0_clk rising edge	6.7		ns
	$t_s(\text{NXTV-CLKH})$	Setup time, hsub0_nxt valid before hsub0_clk rising edge	6.7		ns
HSU4	$t_h(\text{CLKH-DIRIV})$	Hold time, hsub0_dir valid after hsub0_clk rising edge	0.0		ns
	$t_h(\text{CLKH-NXT/IV})$	Hold time, hsub0_nxt valid after hsub0_clk rising edge	0.0		ns
HSU5	$t_s(\text{DATAV-CLKH})$	Setup time, hsub0_data[0:7] valid before hsub0_clk rising edge	6.7		ns
HSU6	$t_h(\text{CLKH-DATIV})$	Hold time, hsub0_data[0:7] valid after hsub0_clk rising edge	0.0		ns

(1) Related with the input maximum frequency supported by the I/F module.

(2) Maximum cycle jitter supported by clk input clock.

(3) The timing requirements are assured for the cycle jitter error condition specified.

Table 6-88. High-Speed USB Switching Characteristics – 12-bit Slave Mode

NO.	PARAMETER		1.15 V		UNIT
			MIN	MAX	
HSU1	$t_d(\text{clkL-STPV})$	Delay time, hsub0_clk high to output usb0_stp valid		9.0	ns
	$t_d(\text{clkL-STPIV})$	Delay time, hsub0_clk high to output usb0_stp invalid	0.5		ns
HSU2	$t_d(\text{clkL-DV})$	Delay time, hsub0_clk high to output hsub0_data[0:7] valid		9.0	ns
	$t_d(\text{clkL-DIV})$	Delay time, hsub0_clk high to output hsub0_data[0:7] invalid	0.5		ns
	$t_r(\text{do})$	Rising time, output signals		2.0	ns
	$t_f(\text{do})$	Falling time, output signals		2.0	ns

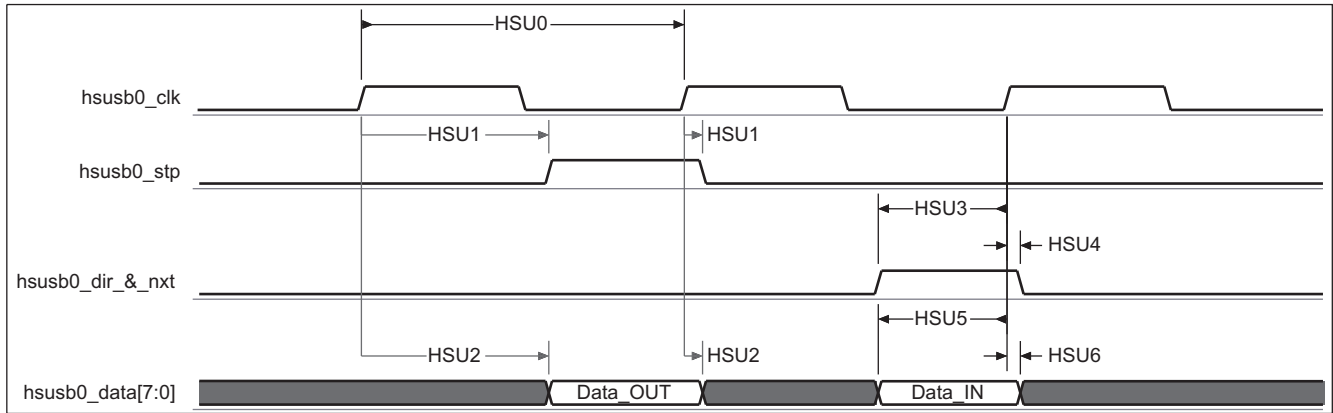

030-086

Figure 6-43. High-Speed USB – 12-bit Slave Mode

6.6.4.2 High-Speed Universal Serial Bus (USB) on Ports 1 and 2 – 12-bit Master Mode

Table 6-90 and Table 6-91 assume testing over the recommended operating conditions (see Figure 6-44).

Table 6-89. High-Speed USB Timing Conditions – 12-bit Master Mode

TIMING CONDITION PARAMETER		VALUE	UNIT
Input Conditions			
t_R	Input signal rise time	2	ns
t_F	Input signal fall time	2	ns
Output Conditions			
C_{LOAD}	Output load capacitance	3	pF

Table 6-90. High-Speed USB Timing Requirements – 12-bit Master Mode⁽¹⁾

NO.	PARAMETER		1.15 V		UNIT
			MIN	MAX	
HSU3	$t_{s(DIRV-CLKH)}$	Setup time, hsubx_dir valid before hsubx_clk rising edge	9.3		ns
	$t_{s(NXTV-CLKH)}$	Setup time, hsubx_nxt valid before hsubx_clk rising edge	9.3		ns
HSU4	$t_{h(CLKH-DIRIV)}$	Hold time, hsubx_dir valid after hsubx_clk rising edge	0.2		ns
	$t_{h(CLKH-NXTIV)}$	Hold time, hsubx_nxt valid after hsubx_clk rising edge	0.2		ns
HSU5	$t_{s(DATAV-CLKH)}$	Setup time, hsubx_data[0:7] valid before hsubx_clk rising edge	9.3		ns
HSU6	$t_{h(CLKH-DATIV)}$	Hold time, hsubx_data[0:7] valid after hsubx_clk rising edge	0.2		ns

(1) In hsubx, x is equal to 1 or 2.

Table 6-91. High-Speed USB Switching Characteristics – 12-bit Master Mode⁽¹⁾

NO.	PARAMETER		1.15 V		UNIT
			MIN	MAX	
HSU0	$f_p(CLK)$	hsubx_clk clock frequency		60	MHz
	$t_j(CLK)$	Jitter standard deviation ⁽²⁾ , hsubx_clk		200	ps
HSU1	$t_d(CLK-STPV)$	Delay time, hsubx_clk high to output hsubx_stp valid		13	ns
	$t_d(CLK-STPIV)$	Delay time, hsubx_clk high to output hsubx_stp invalid	2		ns
HSU2	$t_d(CLK-DV)$	Delay time, hsubx_clk high to output hsubx_data[0:7] valid		13	ns
	$t_d(CLK-DIV)$	Delay time, hsubx_clk high to output hsubx_data[0:7] invalid	2		ns
	$t_R(do)$	Rise time, output signals		2	ns
	$t_F(do)$	Fall time, output signals		2	ns

(1) In hsubx, x is equal to 1 or 2.

(2) The jitter probability density can be approximated by a Gaussian function.

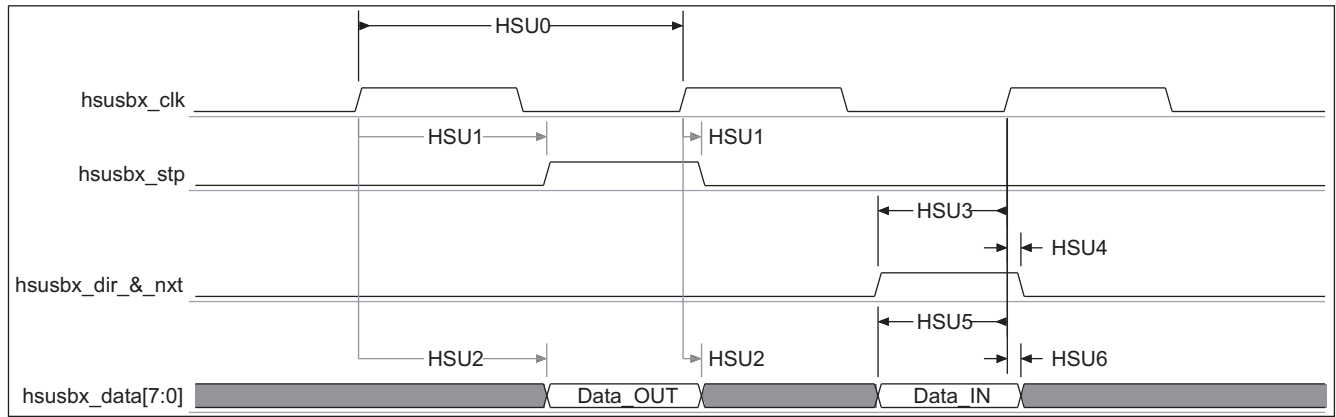

030-087

In hsubx, x is equal to 1 or 2.

Figure 6-44. High-Speed USB – 12-bit Master Mode

6.6.4.3 High-Speed Universal Serial Bus (USB) on Ports 1, 2, and 3 – 12-bit TLL Master Mode

Table 6-93 and Table 6-94 assume testing over the recommended operating conditions (see Figure 6-45).

Table 6-92. High-Speed USB Timing Conditions – 12-bit TLL Master Mode

TIMING CONDITION PARAMETER		VALUE	UNIT
Input Conditions			
t_R	Input signal rise time	2	ns
t_F	Input signal fall time	2	ns
Output Conditions			
C_{LOAD}	Output load capacitance	3	pF

Table 6-93. High-Speed USB Timing Requirements – 12-bit TLL Master Mode⁽¹⁾

NO.	PARAMETER		1.15 V		UNIT
			MIN	MAX	
HSU2	$t_{s(STPV-CLKH)}$	Setup time, hsubx_tll_stp valid before hsubx_tll_clk rising edge	6		ns
HSU3	$t_{s(CLKH-STPIV)}$	Hold time, hsubx_tll_stp valid after hsubx_tll_clk rising edge	0		ns
HSU4	$t_{s(DATAV-CLKH)}$	Setup time, hsubx_tll_data[7:0] valid before hsubx_tll_clk rising edge	6		ns
HSU5	$t_{h(CLKH-DATIV)}$	Hold time, hsubx_tll_data[7:0] valid after hsubx_tll_clk rising edge	0		ns

(1) In hsubx, x is equal to 1, 2, or 3.

Table 6-94. High-Speed USB Switching Characteristics – 12-bit TLL Master Mode⁽¹⁾

NO.	PARAMETER		1.15 V		UNIT
			MIN	MAX	
HSU0	$f_p(CLK)$	hsubx_tll_clk clock frequency		60	MHz
	$t_j(CLK)$	Jitter standard deviation ⁽²⁾ , hsubx_tll_clk		200	ps
HSU6	$t_d(CLKL-DIRV)$	Delay time, hsubx_tll_clk high to output hsubx_tll_dir valid		9	ns
	$t_d(CLKL-DIRIV)$	Delay time, hsubx_tll_clk high to output hsubx_tll_dir invalid	0		ns
	$t_d(CLKL-NXTV)$	Delay time, hsubx_tll_clk high to output hsubx_tll_nxt valid		9	ns
	$t_d(CLKL-NXTIV)$	Delay time, hsubx_tll_clk high to output hsubx_tll_nxt invalid	0		ns
HSU7	$t_d(CLKL-DV)$	Delay time, hsubx_tll_clk high to output hsubx_tll_data[7:0] valid		9	ns
	$t_d(CLKL-DIV)$	Delay time, hsubx_tll_clk high to output hsubx_tll_data[7:0] invalid	0		ns

Table 6-94. High-Speed USB Switching Characteristics – 12-bit TLL Master Mode⁽¹⁾ (continued)

NO.	PARAMETER		1.15 V		UNIT
			MIN	MAX	
	$t_{R(do)}$	Rise time, output signals		2	ns
	$t_{F(do)}$	Fall time, output signals		2	ns

(1) In hsubsx, x is equal to 1, 2, or 3.

(2) The jitter probability density can be approximated by a Gaussian function.

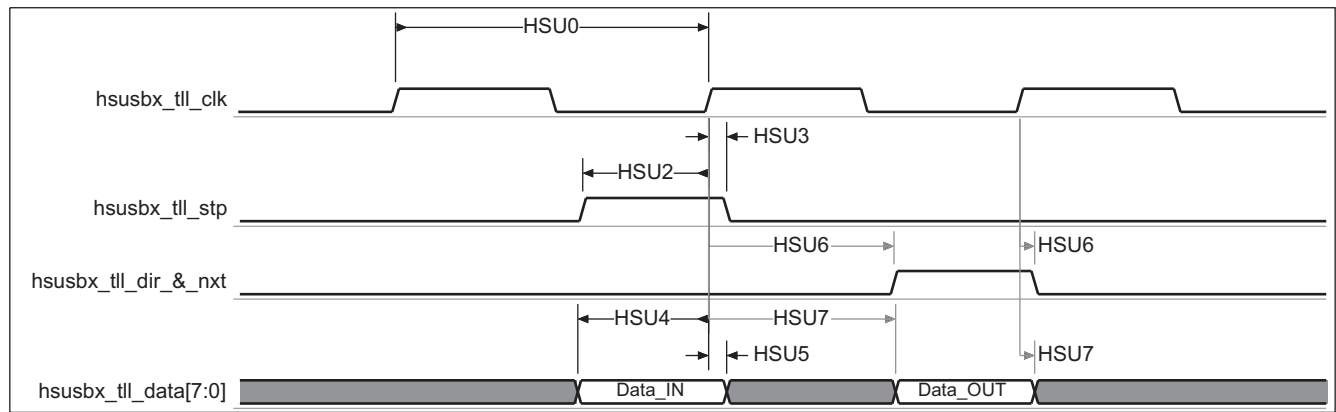

030-088

In hsubsx, x is equal to 1, 2, or 3.

Figure 6-45. High-Speed USB – 12-bit TLL Master Mode

6.6.4.4 High-Speed Universal Serial Bus (USB) on Ports 1, 2, and 3 – 8-bit TLL Master Mode

Table 6-96 and Table 6-97 assume testing over the recommended operating conditions (see Figure 6-46).

Table 6-95. High-Speed USB Timing Conditions – 8-bit TLL Master Mode

TIMING CONDITION PARAMETER		VALUE	UNIT
Input Conditions			
t_R	Input signal rise time	2	ns
t_F	Input signal fall time	2	ns
Output Conditions			
C_{LOAD}	Output load capacitance	3	pF

Table 6-96. High-Speed USB Timing Requirements – 8-bit TLL Master Mode⁽¹⁾

NO.	PARAMETER		1.15 V		UNIT
			MIN	MAX	
HSU2	$t_{S(STPV-CLKH)}$	Setup time, hsubsx_tll_stp valid before hsubsx_tll_clk rising edge	6		ns
HSU3	$t_{S(CLKH-STPIV)}$	Hold time, hsubsx_tll_stp valid after hsubsx_tll_clk rising edge	0		ns
HSU4	$t_{S(DATAV-CLKH)}$	Setup time, hsubsx_tll_data[3:0] valid before hsubsx_tll_clk rising edge	3		ns
HSU5	$t_{H(CLKH-DATIV)}$	Hold time, hsubsx_tll_data[3:0] valid after hsubsx_tll_clk rising edge	-0.8		ns

(1) In hsubsx, x is equal to 1, 2, or 3.

Table 6-97. High-Speed USB Switching Characteristics – 8-bit TLL Master Mode⁽¹⁾

NO.	PARAMETER		1.15 V		UNIT
			MIN	MAX	
HSU0	$f_p(CLK)$	hsubsx_tll_clk clock frequency		60	MHz
	$t_j(CLK)$	Jitter standard deviation ⁽²⁾ , hsubsx_tll_clk		200	ps

Table 6-97. High-Speed USB Switching Characteristics – 8-bit TLL Master Mode⁽¹⁾ (continued)

NO.	PARAMETER		1.15 V		UNIT
			MIN	MAX	
HSU1	$t_{j(\text{CLK})}$	Duty cycle, hsubsx_tll_clk pulse duration (low and high)	47.6%	52.4%	
HSU6	$t_{d(\text{CLKL-DIRV})}$	Delay time, hsubsx_tll_clk high to output hsubsx_tll_dir valid		9	ns
	$t_{d(\text{CLKL-DIRIV})}$	Delay time, hsubsx_tll_clk high to output hsubsx_tll_dir invalid	0		ns
	$t_{d(\text{CLKL-NXTV})}$	Delay time, hsubsx_tll_clk high to output hsubsx_tll_nxt valid		9	ns
	$t_{d(\text{CLKL-NXTIV})}$	Delay time, hsubsx_tll_clk high to output hsubsx_tll_nxt invalid	0		ns
HSU7	$t_{d(\text{CLKL-DV})}$	Delay time, hsubsx_tll_clk high to output hsubsx_tll_data[3:0] valid		4	ns
HSU8	$t_{d(\text{CLKL-DIV})}$	Delay time, hsubsx_tll_clk high to output hsubsx_tll_data[3:0] invalid	0		ns
	$t_{R(\text{do})}$	Rise time, output signals		2	ns
	$t_{F(\text{do})}$	Fall time, output signals		2	ns

(1) In hsubsx, x is equal to 1, 2, or 3.

(2) The jitter probability density can be approximated by a Gaussian function.

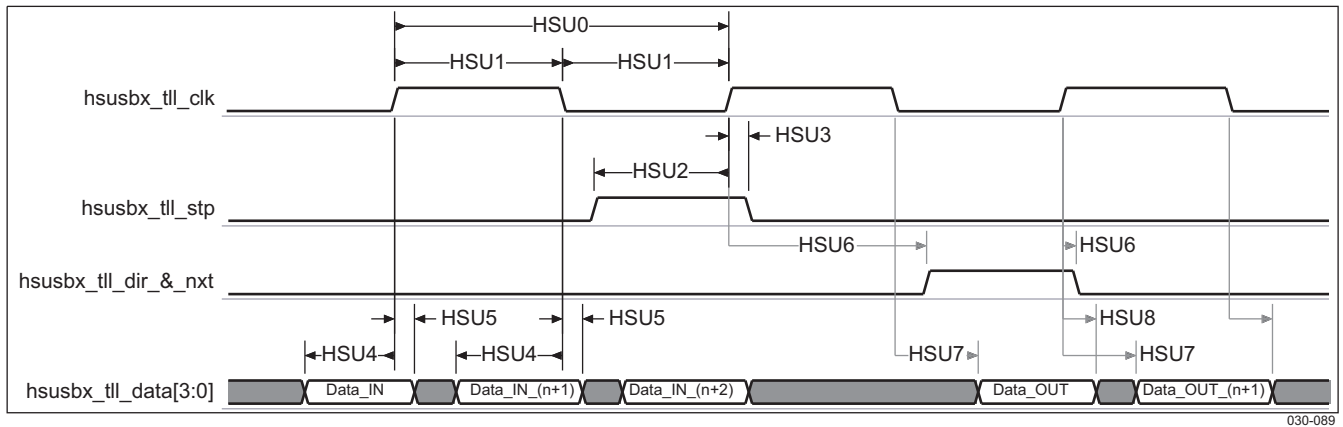

In hsubsx, x is equal to 1, 2, or 3.

Figure 6-46. High-Speed USB – 8-bit TLL Master Mode

PRODUCT PREVIEW

030-089

6.6.5 I²C Interface

The multimaster I²C peripheral provides an interface between two or more devices via an I²C serial bus. The I²C controller supports the multimaster mode which allows more than one device capable of controlling the bus to be connected to it. Each I²C device is recognized by a unique address and can operate as either transmitter or receiver, according to the function of the device. In addition to being a transmitter or receiver, a device connected to the I²C bus can also be considered as master or slave when performing data transfers. This data transfer is carried out via two serial bidirectional wires:

- An SDA data line
- An SCL clock line

The following sections illustrate the data transfer is in master or slave configuration with 7-bit addressing format. The I²C interface is compliant with Philips I²C specification version 2.1. It supports standard mode (up to 100K bits/s), fast mode (up to 400K bits/s) and high-speed mode (up to 3.4Mb/s) .

6.6.5.1 I²C Standard/Fast-Speed Mode

Table 6-98. I²C Standard/Fast-Speed Mode Timings

NO.	PARAMETER ⁽⁴⁾		Standard Mode		Fast Mode		UNIT
			MIN	MAX	MIN	MAX	
	f _{SCL}	Clock Frequency, i2cX_scl		100		400	kHz
I1	t _{w(SCLH)}	Pulse Duration, i2cX_scl high	4		0.6		μs
I2	t _{w(SCLL)}	Pulse Duration, i2cX_scl low	4.7		1.3		μs
I3	t _{su(SDAV-SCLH)}	Setup time, i2cX_sda valid before i2cX_scl active level	250		100 ⁽¹⁾		ns
I4	t _{h(SCLH-SDAV)}	Hold time, i2cX_sda valid after i2cX_scl active level	0 ⁽²⁾	3.45 ⁽³⁾	0 ⁽²⁾	0.9 ⁽³⁾	μs
I5	t _{su(SDAL-SCLH)}	Setup time, i2cX_scl high after i2cX_sda low (for a START ⁽⁵⁾ condition or a repeated START condition)	4.7		0.6		μs
I6	t _{h(SCLH-SDAH)}	Hold time, i2cX_sda low level after i2cX_scl high level (STOP condition)	4		0.6		μs
I7	t _{h(SCLH-RSTART)}	Hold time, i2cX_sda low level after i2cX_scl high level (for a repeated START condition)	4		0.6		μs
I8	t _{w(SDAH)}	Pulse duration, i2cX_sda high between STOP and START conditions	4.7		1.3		μs
	t _{R(SCL)}	Rise time, i2cX_scl		1000		300	ns
	t _{F(SCL)}	Fall time, i2cX_scl		300		300	ns
	t _{R(SDA)}	Rise time, i2cX_sda		1000		300	ns
	t _{F(SDA)}	Fall time, i2cX_sda		300		300	ns
	CB	Capacitive load for each bus line		400		400	pF

- (1) A fast-mode I²C-bus device can be used in a standard-mode I²C-bus system, but the requirement t_{su(SDAV-SCLH)} ≥ 250 ns must then be met. This is automatically the case if the device does not stretch the low period of the i2cx_scl. If such a device does stretch the low period of the i2cx_scl, it must output the next data bit to the i2cx_sda line t_{r(SDA)} max + t_{su(SDAV-SCLH)} = 1000 + 250 = 1250 ns (according to the standard-mode I²C-bus specification) before the i2cx_scl line is released.
- (2) The device provides (via the I²C bus) a hold time of at least 300 ns for the i2cx_sda signal (refer to the fall and rise time of i2cx_scl) to bridge the undefined region of the falling edge of i2cx_scl.
- (3) The maximum t_{h(SCLH-SDA)} has only to be met if the device does not stretch the low period of the i2cx_scl signal.
- (4) In i2cX, X is equal to 1, 2, 3, or 4. Note that I2C4 is master transmitter only.
- (5) After this time, the first clock is generated.

PRODUCT PREVIEW

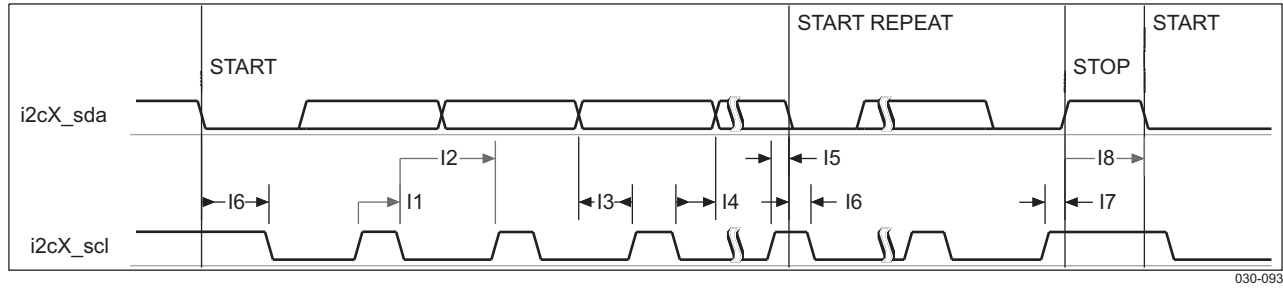

Figure 6-47. I²C – Standard/Fast Mode

PRODUCT PREVIEW

6.6.5.2 I²C High-Speed Mode

Table 6-99. I²C HighSpeed Mode Timings⁽³⁾⁽⁴⁾

NO.	PARAMETER		CB = 100 pF MAX		CB = 400 pF MAX		UNIT
			MIN	MAX	MIN	MAX	
	f _{SCL}	Clock frequency, i2cX_scl		3.4		1.7	MHz
I1	t _{w(SCLH)}	Pulse duration, i2cX_scl high	60 ⁽¹⁾		120 ⁽¹⁾		μs
I2	t _{w(SCLL)}	Pulse duration, i2cX_scl low	160 ⁽¹⁾		320 ⁽¹⁾		μs
I3	t _{su(SDAV-SCLH)}	Setup time, i2cX_sda valid before i2cX_scl active level	10		10		ns
I4	t _{h(SCLH-SDAV)}	Hold time, i2cX_sda valid after i2cX_scl active level	0 ⁽⁴⁾	70	0 ⁽⁴⁾	150	μs
I5	t _{su(SDAL-SCLH)}	Setup time, i2cX_scl high after i2cX_sda low (for a START ⁽²⁾ condition or a repeated START condition)	160		160		μs
I6	t _{h(SCLH-SDAH)}	Hold time, i2cX_sda low level after i2cX_scl high level (STOP condition)	160		160		μs
I7	t _{h(SCLH-RSTART)}	Hold time, i2cX_sda low level after i2cX_scl high level (for a repeated START condition)	160		160		ns
	t _{R(SCL)}	Rise time, i2cX_scl		40		80	ns
	t _{R(SCL)}	Rise time, i2cX_scl after a repeated START condition and after a bit acknowledge		80		160	ns
	t _{F(SCL)}	Fall time, i2cX_scl		40		80	ns
	t _{R(SDA)}	Rise time, i2cX_sda		80		160	ns
	t _{F(SDA)}	Fall time, i2cX_sda		80		160	ns

- (1) HS-mode master devices generate a serial clock signal with a high to low ratio of 1 to 2. t_{w(SCLL)} > 2 × t_{w(SCLH)}.
- (2) After this time, the first clock is generated.
- (3) In i2cX, X is equal to 1, 2, 3, or 4. Note that I2C4 is master transmitter only.
- (4) The device provides (via the I²C bus) a hold time of at least 300 ns for the i2cx_sda signal (refer to the fall and rise time of i2cx_scl) to bridge the undefined region of the falling edge of i2cx_scl.

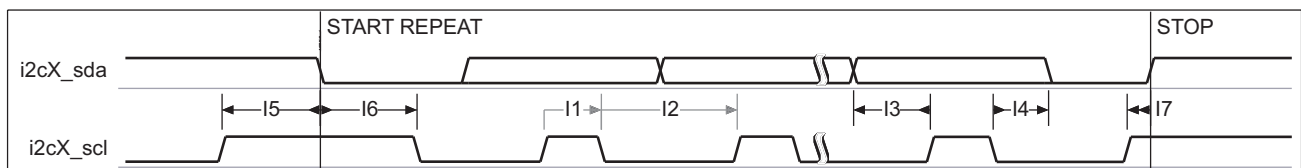

030-094

Figure 6-48. I²C – High-Speed Mode⁽¹⁾⁽²⁾⁽³⁾

- (1) HS-mode master devices generate a serial clock signal with a high-to-low ratio of 1 to 2. t_{w(SCLL)} > 2 × t_{w(SCLH)}.
- (2) In i2cX, X is equal to 1, 2, 3, or 4. Note that I2C4 is master transmitter only.
- (3) After this time, the first clock is generated.

Table 6-100. Correspondence Standard vs. TI Timing References

	TI-OMAP	STANDARD-I ² C	
		S/F Mode	HS Mode
	f _{SCL}	F _{SCL}	F _{SCLH}
I1	t _{w(SCLH)}	T _{HIGH}	T _{HIGH}
I2	t _{w(SCLL)}	T _{LOW}	T _{LOW}
I3	t _{su(SDAV-SCLH)}	T _{SU;DAT}	T _{SU;DAT}
I4	t _{h(SCLH-SDAV)}	T _{SU;DAT}	T _{SU;DAT}
I5	t _{su(SDAL-SCLH)}	T _{SU;STA}	T _{SU;STA}
I6	t _{h(SCLH-SDAH)}	T _{HD;STA}	T _{HD;STA}

Table 6-100. Correspondence Standard vs. TI Timing References (continued)

	TI-OMAP	STANDARD-I ² C	
		S/F Mode	HS Mode
17	$t_{h(SCLH-RSTART)}$	$T_{SU:STO}$	$T_{SU:STO}$
18	$t_{w(SDAH)}$	T_{BUF}	

6.6.6 HDQ / 1-Wire Interfaces

This module is intended to work with both the HDQ and the 1-Wire protocols. The protocols use a single wire to communicate between the master and the slave. The protocols employ an asynchronous return to 1 mechanism where, after any command, the line is pulled high.

6.6.6.1 HDQ Protocol

Table 6-101 and Table 6-102 assume testing over the recommended operating conditions (see Figure 6-49 through Figure 6-52).

Table 6-101. HDQ Timing Requirements

PARAMETER	DESCRIPTION	MIN	MAX	UNIT
t_{CYCD}	Bit window	253		μs
t_{HW1}	Reads 1		68	
t_{HW0}	Reads 0	180		
t_{RSPS}	Command to host respond ⁽¹⁾			

(1) Defined by software.

Table 6-102. HDQ Switching Characteristics

PARAMETER	DESCRIPTION	MIN	TYP	MAX	UNIT
t_B	Break timing		193		μs
t_{BR}	Break recovery		63		
t_{CYCH}	Bit window		253		
t_{DW1}	Sends1 (write)		1.3		
t_{DW0}	Sends0 (write)		101		

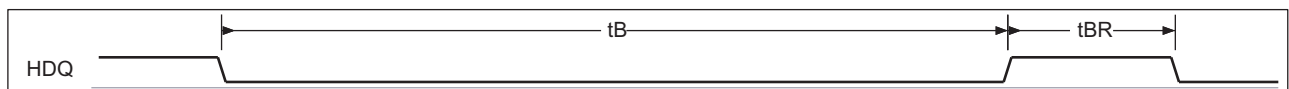

030-095

Figure 6-49. HDQ Break (Reset) Timing

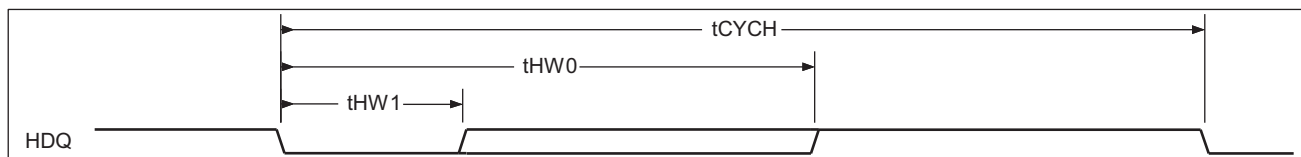

030-096

Figure 6-50. HDQ Read Bit Timing (Data)

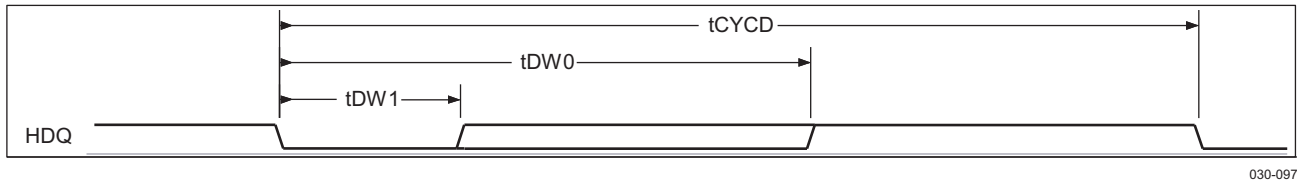

030-097

Figure 6-51. HDQ Write Bit Timing (Command/Address or Data)

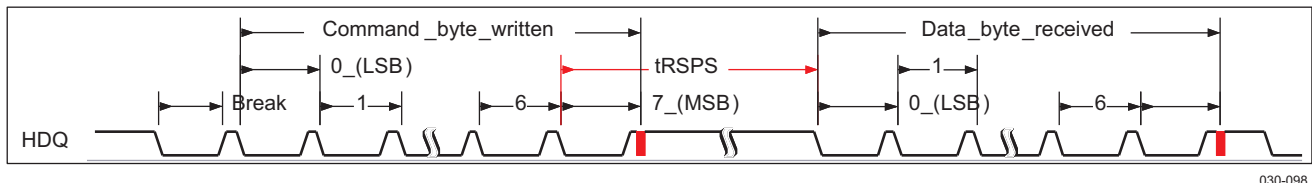

030-098

Figure 6-52. HDQ Communication Timing

6.6.6.2 1-Wire Protocol

Table 6-103 and Table 6-104 assume testing over the recommended operating conditions (see Figure 6-53 through Figure 6-55).

Table 6-103. 1-Wire Timing Requirements

PARAMETER	DESCRIPTION	MIN	MAX	UNIT
t_{PDH}	Presence pulse delay high		68	μs
t_{PDL}	Presence pulse delay low	$68 - t_{PDH}$		
$t_{RDV} + t_{REL}$	Read bit-zero time		102	

Table 6-104. 1-Wire Switching Characteristics

PARAMETER	DESCRIPTION	MIN	TYP	MAX	UNIT
t_{RSTL}	Reset time low		484		μs
t_{RSTH}	Reset time high		484		
t_{SLOT}	Write bit cycle time		102		
t_{LOW1}	Write bit-one time		1.3		
t_{LOW0}	Write bit-zero time		101		
t_{REC}	Recovery time		134		
t_{LOWR}	Read bit strobe time		13		

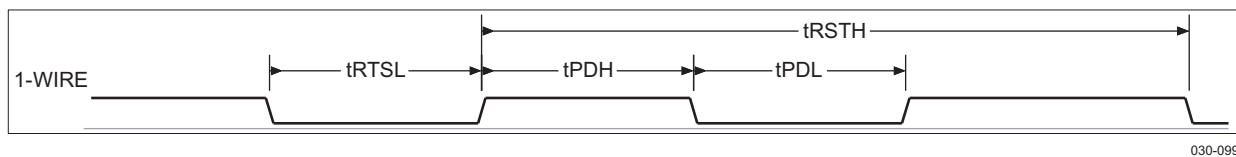

030-099

Figure 6-53. 1-Wire Break (Reset) Timing

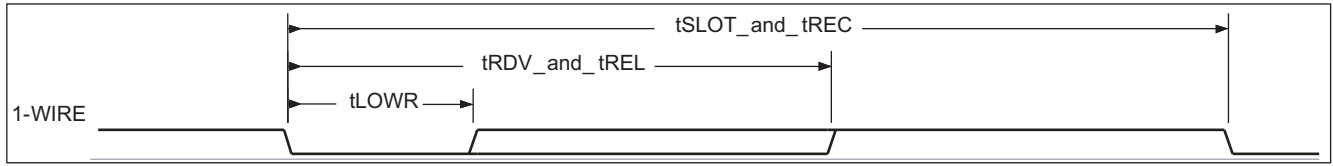

030-100

Figure 6-54. 1-Wire Read Bit Timing (Data)

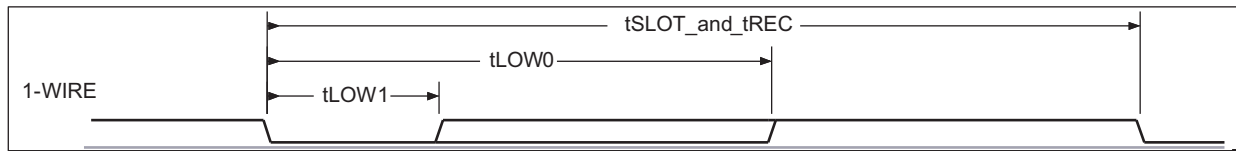

030-101

Figure 6-55. 1-Wire Write Bit Timing (Command/Address or Data)

6.6.7 UART IrDA Interface

The IrDA module can operate in three different modes:

- Slow infrared (SIR) (≤ 115.2 Kbits/s)
- Medium infrared (MIR) (0.576 Mbits/s and 1.152 Mbits/s)
- Fast infrared (FIR) (4 Mbits/s)

For more information about this interface, see the UART/IrDA chapter in the *OMAP35xx ES2.0 Technical Reference Manual (TRM)* [literature number TBD].

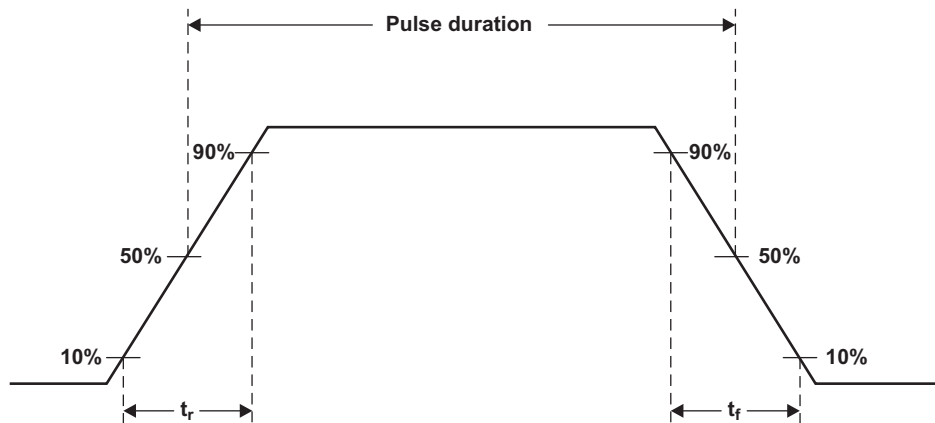

030-118

Figure 6-56. UART IrDA Pulse Parameters

6.6.7.1 IrDA—Receive Mode

Table 6-105. UART IrDA—Signaling Rate and Pulse Duration—Receive Mode

SIGNALING RATE	ELECTRICAL PULSE DURATION			UNIT
	MIN	NOMINAL	MAX	
SIR				
2.4 Kbit/s	1.41	78.1	88.55	μ s
9.6 Kbit/s	1.41	19.5	22.13	μ s
19.2 Kbit/s	1.41	9.75	11.07	μ s

Table 6-105. UART IrDA—Signaling Rate and Pulse Duration—Receive Mode (continued)

SIGNALING RATE	ELECTRICAL PULSE DURATION			UNIT
	MIN	NOMINAL	MAX	
38.4 Kbit/s	1.41	4.87	5.96	μs
57.6 Kbit/s	1.41	3.25	4.34	μs
115.2 Kbit/s	1.41	1.62	2.23	μs
MIR				
0.576 Mbit/s	297.2	416	518.8	ns
1.152 Mbit/s	149.6	208	258.4	ns
FIR				
4.0 Mbit/s (Single pulse)	67	125	164	ns
4.0 Mbit/s (Double pulse)	190	250	289	ns

Table 6-106. UART IrDA—Rise and Fall Time—Receive Mode

	PARAMETER	MAX	UNIT
t _R	Rising time, uart3_rx_irrx	200	ns
t _F	Falling time, uart3_rx_irrx	200	ns

6.6.7.2 IrDA—Transmit Mode

Table 6-107. UART IrDA—Signaling Rate and Pulse Duration—Transmit Mode

SIGNALING RATE	ELECTRICAL PULSE DURATION			UNIT
	MIN	NOMINAL	MAX	
SIR				
2.4 Kbit/s	78.1	78.1	78.1	μs
9.6 Kbit/s	19.5	19.5	19.5	μs
19.2 Kbit/s	9.75	9.75	9.75	μs
38.4 Kbit/s	4.87	4.87	4.87	μs
57.6 Kbit/s	3.25	3.25	3.25	μs
115.2 Kbit/s	1.62	1.62	1.62	μs
MIR				
0.576 Mbit/s	414	416	419	ns
1.152 Mbit/s	206	208	211	ns
FIR				
4.0 Mbit/s (Single pulse)	123	125	128	ns
4.0 Mbit/s (Double pulse)	248	250	253	ns

6.7 Removable Media Interfaces

6.7.1 High-Speed Multimedia Memory Card (MMC) and Secure Digital IO Card (SDIO) Timing

The MMC/SDIO host controller provides an interface to high-speed and standard MMC, SD memory cards, or SDIO cards. The application interface is responsible for managing transaction semantics. The MMC/SDIO host controller deals with MMC/SDIO protocol at transmission level, packing data, adding CRC, start/end bit, and checking for syntactical correctness.

There are three MMC interfaces on the OMAP3515/03:

- MMC/SD/SDIO Interface 1:
 - 1.8 V/3 V support
 - 8 bits
- MMC/SD/SDIO Interface 2:
 - 1.8 V support
 - 8 bits
 - 4 bits with external transceiver allowing to support 3 V peripherals. Transceiver direction control signals are multiplexed with the upper four data bits.
- MMC/SD/SDIO Interface 3:
 - 1.8 V support
 - 8 bits

6.7.1.1 MMC/SD/SDIO in SD Identification Mode

Table 6-109 and Table 6-110 assume testing over the recommended operating conditions and electrical characteristic conditions.

Table 6-108. MMC/SD/SDIO Timing Conditions – SD Identification Mode

TIMING CONDITION PARAMETER		VALUE	UNIT
SD Identification Mode			
Input Conditions			
t_R	Input signal rise time	10	ns
t_F	Input signal fall time	10	ns
Output Conditions			
C_{LOAD}	Output load capacitance	40	pF

Table 6-109. MMC/SD/SDIO Timing Requirements – SD Identification Mode⁽¹⁾⁽²⁾⁽³⁾

NO.	PARAMETER	1.15 V		1.0 V		UNIT
		MIN	MAX	MIN	MAX	
SD Identification Mode						
MMC/SD/SDIO Interface 1 (1.8 V IO)						
HSSD3/SD3	$t_{su}(CMDV-CLKIH)$	Setup time, mmc1_cmd valid before mmc1_clk rising clock edge		1198.4		ns
HSSD4/SD4	$t_{su}(CLKIH-CMDIV)$	Hold time, mmc1_cmd valid after mmc1_clk rising clock edge		1249.2	1249.2	ns
MMC/SD/SDIO Interface 1 (3.0 V IO)						
HSSD3/SD3	$t_{su}(CMDV-CLKIH)$	Setup time, mmc1_cmd valid before mmc1_clk rising clock edge		1198.4		ns
HSSD4/SD4	$t_{su}(CLKIH-CMDIV)$	Hold time, mmc1_cmd valid after mmc1_clk rising clock edge		1249.2	1249.2	ns
MMC/SD/SDIO Interface 2						

Table 6-109. MMC/SD/SDIO Timing Requirements – SD Identification Mode⁽¹⁾⁽²⁾⁽³⁾ (continued)

NO.	PARAMETER		1.15 V		1.0 V		UNIT
			MIN	MAX	MIN	MAX	
HSSD3/SD3	t _{su} (CMDV-CLKIH)	Setup time, mmc2_cmd valid before mmc2_clk rising clock edge	1198.4		1198.4		ns
HSSD4/SD4	t _{su} (CLKIH-CMDIV)	Hold time, mmc2_cmd valid after mmc2_clk rising clock edge	1249.2		1249.2		ns
MMC/SD/SDIO Interface 3							
HSSD3/SD3	t _{su} (CMDV-CLKIH)	Setup time, mmc3_cmd valid before mmc3_clk rising clock edge	1198.4		1198.4		ns
HSSD4/SD4	t _{su} (CLKIH-CMDIV)	Hold time, mmc3_cmd valid after mmc3_clk rising clock edge	1249.2		1249.2		ns

(1) Timing parameters are referred to output clock specified in [Table 6-110](#).

(2) The timing requirements are assured for the cycle jitter and duty cycle error conditions specified in [Table 6-110](#).

(3) Corresponding figures showing timing parameters are common with other interface modes. (See SD and HS SD modes).

Table 6-110. MMC/SD/SDIO Switching Characteristics – SD Identification Mode⁽⁴⁾

NO.	PARAMETER		1.15 V		1.0 V		UNIT
			MIN	MAX	MIN	MAX	
SD Identification Mode							
HSSD1/SD1	t _c (clk)	Cycle time ⁽¹⁾ , output clk period	2500		2500		ns
HSSD2/SD2	t _W (clkH)	Typical pulse duration, output clk high	X ⁽⁵⁾ *PO ⁽²⁾		X ⁽⁵⁾ *PO ⁽²⁾		ns
HSSD2/SD2	t _W (clkL)	Typical pulse duration, output clk low	Y ⁽⁶⁾ *PO ⁽²⁾		Y ⁽⁶⁾ *PO ⁽²⁾		ns
	t _{dc} (clk)	Duty cycle error, output clk		125		125	ns
	t _j (clk)	Jitter standard deviation ⁽³⁾ , output clk		200		200	ps
MMC/SD/SDIO Interface 1 (1.8 V IO)							
	t _c (clk)	Rise time, output clk		10		10	ns
	t _W (clkH)	Fall time, output clk		10		10	ns
	t _W (clkL)	Rise time, output data		10		10	ns
	t _{dc} (clk)	Fall time, output data		10		10	ns
HSSD5/SD5	t _d (CLKOH-CMD)	Delay time, mmc1_clk rising clock edge to mmc1_cmd transition	6.3	2492.7	6.3	2492.7	ns
MMC/SD/SDIO Interface 1 (3.0 V IO)							
	t _c (clk)	Rise time, output clk		10		0	ns
	t _W (clkH)	Fall time, output clk		10		0	ns
	t _W (clkL)	Rise time, output data		10		10	ns
	t _{dc} (clk)	Fall time, output data		10		10	ns
HSSD5/SD5	t _d (CLKOH-CMD)	Delay time, mmc1_clk rising clock edge to mmc1_cmd transition	6.3	2492.7	6.3	2492.7	ns
MMC/SD/SDIO Interface 2							
	t _c (clk)	Rise time, output clk		10		10	ns
	t _W (clkH)	Fall time, output clk		10		10	ns
	t _W (clkL)	Rise time, output data		10		10	ns
	t _{dc} (clk)	Fall time, output data		10		10	ns
HSSD5/SD5	t _d (CLKOH-CMD)	Delay time, mmc2_clk rising clock edge to mmc2_cmd transition	6.3	2492.7	6.3	2492.7	ns
MMC/SD/SDIO Interface 3							
	t _c (clk)	Rise time, output clk		10		10	ns
	t _W (clkH)	Fall time, output clk		10		10	ns
	t _W (clkL)	Rise time, output data		10		10	ns
	t _{dc} (clk)	Fall time, output data		10		10	ns

Table 6-110. MMC/SD/SDIO Switching Characteristics – SD Identification Mode⁽⁴⁾ (continued)

NO.	PARAMETER		1.15 V		1.0 V		UNIT
			MIN	MAX	MIN	MAX	
HSSD5/SD5	$t_{d(CLKOH-CMD)}$	Delay time, mmc3_clk rising clock edge to mmc3_cmd transition	6.3	2492.7	6.3	2492.7	ns

- (1) Related with the output clk maximum and minimum frequencies programmable in I/F module.
- (2) PO = output clk period in ns.
- (3) The jitter probability density can be approximated by a Gaussian function.
- (4) Corresponding figures showing timing parameters are common with other interface modes (see SD and HS SD modes).
- (5) The X parameter is defined as follows.

CLKD	X
1 or Even	0.5
Odd	$(\text{trunk}[\text{CLKD}/2]+1)/\text{CLKD}$

For details about clock division factor CLKD, see the *OMAP35xx ES2.0 Technical Reference Manual (TRM)* [literature number [SPRUF98](#)].

- (6) The Y parameter is defined as follows.

CLKD	Y
1 or Even	0.5
Odd	$(\text{trunk}[\text{CLKD}/2])/ \text{CLKD}$

For details about clock division factor CLKD, see the *OMAP35xx ES2.0 Technical Reference Manual (TRM)* [literature number [SPRUF98](#)].

6.7.1.2 MMC/SD/SDIO in High-Speed MMC Mode

Table 6-112 and Table 6-113 assume testing over the recommended operating conditions and electrical characteristic conditions (see Figure 6-57 and Figure 6-58).

Table 6-111. MMC/SD/SDIO Timing Conditions – High-Speed MMC Mode

TIMING CONDITION PARAMETER		VALUE	UNIT
High-Speed MMC Mode			
Input Conditions			
t_R	Input signal rise time	3	ns
t_F	Input signal fall time	3	ns
Output Conditions			
C_{LOAD}	Output load capacitance	30	pF

Table 6-112. MMC/SD/SDIO Timing Requirements – High-Speed MMC Mode⁽¹⁾⁽²⁾⁽³⁾⁽⁴⁾

NO.	PARAMETER		1.15 V		1.0 V		UNIT
			MIN	MAX	MIN	MAX	
High-Speed MMC Mode							
MMC/SD/SDIO Interface 1 (1.8 V IO)							
MMC3	$t_{su(CMDV-CLKIH)}$	Setup time, mmc1_cmd valid before mmc1_clk rising clock edge	5.6		26		ns
MMC4	$t_{su(CLKIH-CMDIV)}$	Hold time, mmc1_cmd valid after mmc1_clk rising clock edge	2.3		1.9		ns
MMC7	$t_{su(DATxV-CLKIH)}$	Setup time, mmc1_datx valid before mmc1_clk rising clock edge	5.6		26		ns
MMC8	$t_{su(CLKIH-DATxIV)}$	Hold time, mmc1_datx valid after mmc1_clk rising clock edge	2.3		1.9		ns
MMC/SD/SDIO Interface 1 (3.0 V IO)							

Table 6-112. MMC/SD/SDIO Timing Requirements – High-Speed MMC Mode⁽¹⁾⁽²⁾⁽³⁾⁽⁴⁾ (continued)

NO.	PARAMETER		1.15 V		1.0 V		UNIT
			MIN	MAX	MIN	MAX	
MMC3	$t_{su}(CMDV-CLKIH)$	Setup time, mmc1_cmd valid before mmc1_clk rising clock edge	5.6		26		ns
MMC4	$t_{su}(CLKIH-CMDIV)$	Hold time, mmc1_cmd valid after mmc1_clk rising clock edge	2.3		1.9		ns
MMC7	$t_{su}(DATxV-CLKIH)$	Setup time, mmc1_datx valid before mmc1_clk rising clock edge	5.6		26		ns
MMC8	$t_{su}(CLKIH-DATxIV)$	Hold time, mmc1_datx valid after mmc1_clk rising clock edge	2.3		1.9		ns
MMC/SD/SDIO Interface 2							
MMC3	$t_{su}(CMDV-CLKIH)$	Setup time, mmc2_cmd valid before mmc2_clk rising clock edge	5.6		26		ns
MMC4	$t_{su}(CLKIH-CMDIV)$	Hold time, mmc2_cmd valid after mmc2_clk rising clock edge	2.3		1.9		ns
MMC7	$t_{su}(DATxV-CLKIH)$	Setup time, mmc2_datx valid before mmc2_clk rising clock edge	5.6		26		ns
MMC8	$t_{su}(CLKIH-DATxIV)$	Hold time, mmc2_datx valid after mmc2_clk rising clock edge	2.3		1.9		ns
MMC/SD/SDIO Interface 3							
MMC3	$t_{su}(CMDV-CLKIH)$	Setup time, mmc3_cmd valid before mmc3_clk rising clock edge	5.6		26		ns
MMC4	$t_{su}(CLKIH-CMDIV)$	Hold time, mmc3_cmd valid after mmc3_clk rising clock edge	2.3		1.9		ns
MMC7	$t_{su}(DATxV-CLKIH)$	Setup time, mmc3_datx valid before mmc3_clk rising clock edge	5.6		26		ns
MMC8	$t_{su}(CLKIH-DATxIV)$	Hold time, mmc3_datx valid after mmc3_clk rising clock edge	2.3		1.9		ns

- (1) Timing parameters are referred to output clock specified in [Table 6-113](#).
- (2) The timing requirements are assured for the cycle jitter and duty cycle error conditions specified in [Table 6-113](#).
- (3) Corresponding figures showing timing parameters are common with Standard MMC mode (See [Figure 6-57](#) and [Figure 6-58](#))
- (4) In datx, x is equal to 1, 2, 3, 4, 5, 6, or 7.

Table 6-113. MMC/SD/SDIO Switching Characteristics – High-Speed MMC Mode⁽⁴⁾⁽⁷⁾

NO.	PARAMETER		1.15 V		1.0 V		UNIT
			MIN	MAX	MIN	MAX	
High-Speed MMC Mode							
MMC1	$t_{c}(clk)$	Cycle time ⁽¹⁾ , output clk period	20.8		41.7		ns
MMC2	$t_{W}(clkH)$	Typical pulse duration, output clk high	$X^{(5)} \cdot PO^{(2)}$		$X^{(5)} \cdot PO^{(2)}$		ns
MMC2	$t_{W}(clkL)$	Typical pulse duration, output clk low	$Y^{(6)} \cdot PO^{(2)}$		$Y^{(6)} \cdot PO^{(2)}$		ns
	$t_{dc}(clk)$	Duty cycle error, output clk		1041.7		2083.3	ps
	$t_{j}(clk)$	Jitter standard deviation ⁽³⁾ , output clk		200		200	ps
MMC/SD/SDIO Interface 1 (1.8 V IO)							
	$t_{c}(clk)$	Rise time, output clk		3		3	ns
	$t_{W}(clkH)$	Fall time, output clk		3		3	ns
	$t_{W}(clkL)$	Rise time, output data		3		3	ns
	$t_{dc}(clk)$	Fall time, output data		3		3	ns
MMC5	$t_{d}(CLKOH-CMD)$	Delay time, mmc1_clk rising clock edge to mmc1_cmd transition	3.7	14.1	4.1	34.5	ns
MMC6	$t_{d}(CLKOH-DATx)$	Delay time, mmc1_clk rising clock edge to mmc1_datx transition	3.7	14.1	4.1	34.5	ns
MMC/SD/SDIO Interface 1 (3.0 V IO)							

Table 6-113. MMC/SD/SDIO Switching Characteristics – High-Speed MMC Mode⁽⁴⁾⁽⁷⁾ (continued)

N O.	PARAMETER		1.15 V		1.0 V		UNIT
			MIN	MAX	MIN	MAX	
	$t_{c(\text{clk})}$	Rise time, output clk		3		3	ns
	$t_{W(\text{clkH})}$	Fall time, output clk		3		3	ns
	$t_{W(\text{clkL})}$	Rise time, output data		3		3	ns
	$t_{dc(\text{clk})}$	Fall time, output data		3		3	ns
MMC5	$t_{d(\text{CLKOH-CMD})}$	Delay time, mmc1_clk rising clock edge to mmc1_cmd transition	3.7	14.1	4.1	34.5	ns
MMC6	$t_{d(\text{CLKOH-DATx})}$	Delay time, mmc1_clk rising clock edge to mmc1_datx transition	3.7	14.1	4.1	34.5	ns
MMC/SD/SDIO Interface 2							
	$t_{c(\text{clk})}$	Rise time, output clk		3		3	ns
	$t_{W(\text{clkH})}$	Fall time, output clk		3		3	ns
	$t_{W(\text{clkL})}$	Rise time, output data		3		3	ns
	$t_{dc(\text{clk})}$	Fall time, output data		3		3	ns
MMC5	$t_{d(\text{CLKOH-CMD})}$	Delay time, mmc2_clk rising clock edge to mmc2_cmd transition	3.7	14.1	4.1	34.5	ns
MMC6	$t_{d(\text{CLKOH-DATx})}$	Delay time, mmc2_clk rising clock edge to mmc2_datx transition	3.7	16.5	4.1	36.9	ns
MMC/SD/SDIO Interface 3							
	$t_{c(\text{clk})}$	Rise time, output clk		3		3	ns
	$t_{W(\text{clkH})}$	Fall time, output clk		3		3	ns
	$t_{W(\text{clkL})}$	Rise time, output data		3		3	ns
	$t_{dc(\text{clk})}$	Fall time, output data		3		3	ns
MMC5	$t_{d(\text{CLKOH-CMD})}$	Delay time, mmc3_clk rising clock edge to mmc3_cmd transition	3.7	14.1	4.1	34.5	ns
MMC6	$t_{d(\text{CLKOH-DATx})}$	Delay time, mmc3_clk rising clock edge to mmc3_datx transition	3.7	14.1	4.1	34.5	ns

PRODUCT PREVIEW

- (1) Related with the output clk maximum and minimum frequencies programmable in I/F module.
- (2) PO = output clk period in ns.
- (3) The jitter probability density can be approximated by a Gaussian function.
- (4) In datx, x is equal to 1, 2, 3, 4, 5, 6, or 7.
- (5) The X parameter is defined as follows.

CLKD	X
1 or Even	0.5
Odd	$(\text{trunk}[\text{CLKD}/2]+1)/\text{CLKD}$

For details about clock division factor CLKD, see the *OMAP35xx ES2.0 Technical Reference Manual (TRM)* [literature number [SPRUF98](#)].

- (6) The Y parameter is defined as follows.

CLKD	Y
1 or Even	0.5
Odd	$(\text{trunk}[\text{CLKD}/2])/ \text{CLKD}$

For details about clock division factor CLKD, see the *OMAP35xx ES2.0 Technical Reference Manual (TRM)* [literature number [SPRUF98](#)].

- (7) Corresponding figures showing timing parameters are common with Standard MMC mode (See [Figure 6-57](#) and [Figure 6-58](#))

6.7.1.3 MMC/SD/SDIO in Standard MMC Mode and MMC Identification Mode

[Table 6-115](#) and [Table 6-116](#) assume testing over the recommended operating conditions and electrical characteristic conditions.

Table 6-114. MMC/SD/SDIO Timing Conditions – Standard MMC Mode and MMC Identification Mode

TIMING CONDITION PARAMETER		VALUE	UNIT
Standard MMC Mode and MMC Identification Mode			
Input Conditions			
t_R	Input signal rise time	10	ns
t_F	Input signal fall time	10	ns
Output Conditions			
C_{LOAD}	Output load capacitance	30	pF

PRODUCT PREVIEW

Table 6-115. MMC/SD/SDIO Timing Requirements – Standard MMC Mode and MMC Identification Mode⁽¹⁾⁽²⁾

NO.	PARAMETER		1.15 V		1.0 V		UNIT
			MIN	MAX	MIN	MAX	
Standard MMC Mode and MMC Identification Mode							
MMC/SD/SDIO Interface 1 (1.8 V IO)							
MMC3	$t_{su}(CMDV-CLKIH)$	Setup time, mmc1_cmd valid before mmc1_clk rising clock edge	13.6		65.7		ns
MMC4	$t_{su}(CLKIH-CMDIV)$	Hold time, mmc1_cmd valid after mmc1_clk rising clock edge	8.9		8.9		ns
MMC7	$t_{su}(DATxV-CLKIH)$	Setup time, mmc1_datx valid before mmc1_clk rising clock edge	13.6		65.7		ns
MMC8	$t_{su}(CLKIH-DATxIV)$	Hold time, mmc1_datx valid after mmc1_clk rising clock edge	8.9		8.9		ns
MMC/SD/SDIO Interface 1 (3.0 V IO)							
MMC3	$t_{su}(CMDV-CLKIH)$	Setup time, mmc1_cmd valid before mmc1_clk rising clock edge	13.6		65.7		ns
MMC4	$t_{su}(CLKIH-CMDIV)$	Hold time, mmc1_cmd valid after mmc1_clk rising clock edge	8.9		8.9		ns
MMC7	$t_{su}(DATxV-CLKIH)$	Setup time, mmc1_datx valid before mmc1_clk rising clock edge	13.6		65.7		ns
MMC8	$t_{su}(CLKIH-DATxIV)$	Hold time, mmc1_datx valid after mmc1_clk rising clock edge	8.9		8.9		ns
MMC/SD/SDIO Interface 2							
MMC3	$t_{su}(CMDV-CLKIH)$	Setup time, mmc2_cmd valid before mmc2_clk rising clock edge	13.6		65.7		ns
MMC4	$t_{su}(CLKIH-CMDIV)$	Hold time, mmc2_cmd valid after mmc2_clk rising clock edge	8.9		8.9		ns
MMC7	$t_{su}(DATxV-CLKIH)$	Setup time, mmc2_datx valid before mmc2_clk rising clock edge	13.6		65.7		ns
MMC8	$t_{su}(CLKIH-DATxIV)$	Hold time, mmc2_datx valid after mmc2_clk rising clock edge	8.9		8.9		ns
MMC/SD/SDIO Interface 3							
MMC3	$t_{su}(CMDV-CLKIH)$	Setup time, mmc3_cmd valid before mmc3_clk rising clock edge	13.6		65.7		ns
MMC4	$t_{su}(CLKIH-CMDIV)$	Hold time, mmc3_cmd valid after mmc3_clk rising clock edge	8.9		8.9		ns
MMC7	$t_{su}(DATxV-CLKIH)$	Setup time, mmc3_datx valid before mmc3_clk rising clock edge	13.6		65.7		ns
MMC8	$t_{su}(CLKIH-DATxIV)$	Hold time, mmc3_datx valid after mmc3_clk rising clock edge	8.9		8.9		ns

(1) Timing parameters are referred to output clock specified in [Table 6-116](#).

(2) The timing requirements are assured for the cycle jitter and duty cycle error conditions specified in [Table 6-116](#).

(3) In datx, x is equal to 1, 2, 3, 4, 5, 6, or 7.

Table 6-116. MMC/SD/SDIO Switching Characteristics – Standard MMC Mode and MMC Identification Mode

NO.	PARAMETER		1.15 V		1.0 V		UNIT
			MIN	MAX	MIN	MAX	
MMC Identification Mode							
MMC1	$t_{c}(clk)$	Cycle time ⁽¹⁾ , output clk period	2500		2500		ns
MMC2	$t_{W}(clkH)$	Typical pulse duration, output clk high	$X^{(5)} \cdot PO^{(2)}$		$X^{(5)} \cdot PO^{(2)}$		ns
MMC2	$t_{W}(clkL)$	Typical pulse duration, output clk low	$Y^{(6)} \cdot PO^{(2)}$		$Y^{(6)} \cdot PO^{(2)}$		ns
	$t_{dc}(clk)$	Duty cycle error, output clk		125		125	ns
	$t_{j}(clk)$	Jitter standard deviation ⁽³⁾ , output clk		200		200	ps

Table 6-116. MMC/SD/SDIO Switching Characteristics – Standard MMC Mode and MMC Identification Mode (continued)

NO.	PARAMETER	1.15 V		1.0 V		UNIT
		MIN	MAX	MIN	MAX	
Standard MMC Mode						
MMC1	$t_{c(\text{clk})}$	Cycle time ⁽¹⁾ , output clk period		52.1	104.2	ns
MMC2	$t_{W(\text{clkH})}$	Typical pulse duration, output clk high		$X^{(5)} \cdot PO^{(2)}$	$X^{(5)} \cdot PO^{(2)}$	ns
MMC2	$t_{W(\text{clkL})}$	Typical pulse duration, output clk low		$Y^{(6)} \cdot PO^{(2)}$	$Y^{(6)} \cdot PO^{(2)}$	ns
	$t_{dc(\text{clk})}$	Duty cycle error, output clk		2604.2	5208.3	ps
	$t_{j(\text{clk})}$	Jitter standard deviation ⁽³⁾ , output clk		200	200	ps
MMC/SD/SDIO Interface 1 (1.8 V IO)						
	$t_{c(\text{clk})}$	Rise time, output clk		10	10	ns
	$t_{W(\text{clkH})}$	Fall time, output clk		10	10	ns
	$t_{W(\text{clkL})}$	Rise time, output data		10	10	ns
	$t_{dc(\text{clk})}$	Fall time, output data		10	10	ns
MMC5	$t_{d(\text{CLKOH-CMD})}$	Delay time, mmc1_clk rising clock edge to mmc1_cmd transition		4.3	47.8	ns
MMC6	$t_{d(\text{CLKOH-DATx})}$	Delay time, mmc1_clk rising clock edge to mmc1_datx transition		4.3	47.8	ns
MMC/SD/SDIO Interface 1 (3.0 V IO)						
	$t_{c(\text{clk})}$	Rise time, output clk		10	10	ns
	$t_{W(\text{clkH})}$	Fall time, output clk		10	10	ns
	$t_{W(\text{clkL})}$	Rise time, output data		10	10	ns
	$t_{dc(\text{clk})}$	Fall time, output data		10	10	ns
MMC5	$t_{d(\text{CLKOH-CMD})}$	Delay time, mmc1_clk rising clock edge to mmc1_cmd transition		4.3	47.8	ns
MMC6	$t_{d(\text{CLKOH-DATx})}$	Delay time, mmc1_clk rising clock edge to mmc1_datx transition		4.3	47.8	ns
MMC/SD/SDIO Interface 2						
	$t_{c(\text{clk})}$	Rise time, output clk		10	10	ns
	$t_{W(\text{clkH})}$	Fall time, output clk		10	10	ns
	$t_{W(\text{clkL})}$	Rise time, output data		10	10	ns
	$t_{dc(\text{clk})}$	Fall time, output data		10	10	ns
MMC5	$t_{d(\text{CLKOH-CMD})}$	Delay time, mmc2_clk rising clock edge to mmc2_cmd transition		4.3	47.8	ns
MMC6	$t_{d(\text{CLKOH-DATx})}$	Delay time, mmc2_clk rising clock edge to mmc2_datx transition		4.3	47.8	ns
MMC/SD/SDIO Interface 3						
	$t_{c(\text{clk})}$	Rise time, output clk		10	10	ns
	$t_{W(\text{clkH})}$	Fall time, output clk		10	10	ns
	$t_{W(\text{clkL})}$	Rise time, output data		10	10	ns
	$t_{dc(\text{clk})}$	Fall time, output data		10	10	ns
MMC5	$t_{d(\text{CLKOH-CMD})}$	Delay time, mmc3_clk rising clock edge to mmc3_cmd transition		4.3	47.8	ns
MMC6	$t_{d(\text{CLKOH-DATx})}$	Delay time, mmc3_clk rising clock edge to mmc3_datx transition		4.3	47.8	ns

(1) Related with the output clk maximum and minimum frequencies programmable in I/F module.

(2) PO = output clk period in ns.

(3) The jitter probability density can be approximated by a Gaussian function.

(4) In datx, x is equal to 1, 2, 3, 4, 5, 6, or 7.

(5) The X parameter is defined as follows.

CLKD	X
1 or Even	0.5
Odd	$(\text{trunk}[\text{CLKD}/2]+1)/\text{CLKD}$

For details about clock division factor CLKD, see the *OMAP35xx ES2.0 Technical Reference Manual (TRM)* [literature number [SPRUF98](#)].

(6) The Y parameter is defined as follows.

CLKD	Y
1 or Even	0.5
Odd	$(\text{trunk}[\text{CLKD}/2])/\text{CLKD}$

For details about clock division factor CLKD, see the *OMAP35xx ES2.0 Technical Reference Manual (TRM)* [literature number [SPRUF98](#)].

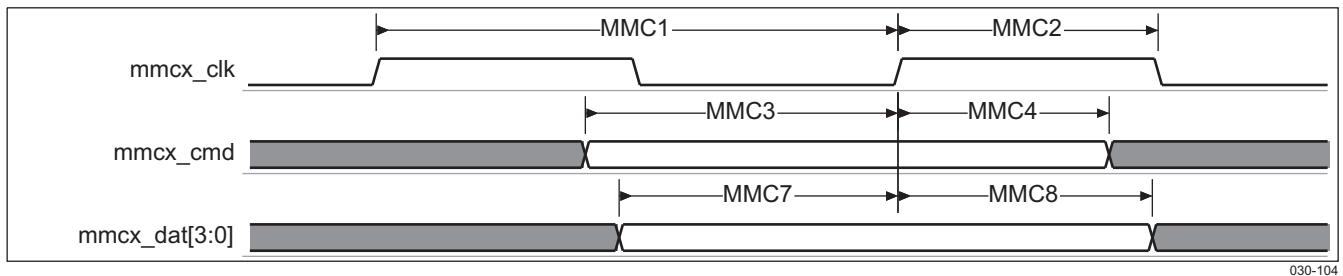

In mmc_x, x is equal to 1, 2, or 3.

Figure 6-57. MMC/SD/SDIO – High-Speed and Standard MMC Modes – Data/Command Receive

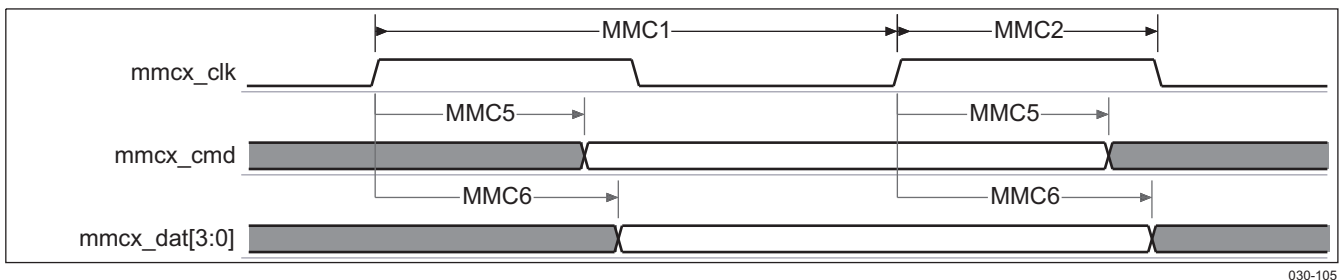

In mmc_x, x is equal to 1, 2, or 3.

Figure 6-58. MMC/SD/SDIO – High-Speed and Standard MMC Modes – Data/Command Transmit

6.7.1.4 MMC/SD/SDIO in High-Speed SD Mode

[Table 6-118](#) and [Table 6-119](#) assume testing over the recommended operating conditions and electrical characteristic conditions.

Table 6-117. MMC/SD/SDIO Timing Conditions – High-Speed SD Mode

TIMING CONDITION PARAMETER		VALUE	UNIT
High-Speed SD Mode			
Input Conditions			
t_R	Input signal rise time	3	ns
t_F	Input signal fall time	3	ns
Output Conditions			
C_{LOAD}	Output load capacitance	40	pF

Table 6-118. MMC/SD/SDIO Timing Requirements – High-Speed SD Mode⁽¹⁾⁽²⁾⁽³⁾

NO.	PARAMETER		1.15 V		1.0 V		UNIT
			MIN	MAX	MIN	MAX	
High-Speed SD Mode							
MMC/SD/SDIO Interface 1 (1.8 V IO)							
HSSD3	$t_{su}(CMDV-CLKIH)$	Setup time, mmc1_cmd valid before mmc1_clk rising clock edge	5.6		26		ns
HSSD4	$t_{su}(CLKIH-CMDIV)$	Hold time, mmc1_cmd valid after mmc1_clk rising clock edge	2.3		1.9		ns
HSSD7	$t_{su}(DATxV-CLKIH)$	Setup time, mmc1_datx valid before mmc1_clk rising clock edge	5.6		26		ns
HSSD8	$t_{su}(CLKIH-DATxIV)$	Hold time, mmc1_datx valid after mmc1_clk rising clock edge	2.3		1.9		ns
MMC/SD/SDIO Interface 1 (3.0 V IO)							
HSSD3	$t_{su}(CMDV-CLKIH)$	Setup time, mmc1_cmd valid before mmc1_clk rising clock edge	5.6		26		ns
HSSD4	$t_{su}(CLKIH-CMDIV)$	Hold time, mmc1_cmd valid after mmc1_clk rising clock edge	2.3		1.9		ns
HSSD7	$t_{su}(DATxV-CLKIH)$	Setup time, mmc1_datx valid before mmc1_clk rising clock edge	5.6		26		ns
HSSD8	$t_{su}(CLKIH-DATxIV)$	Hold time, mmc1_datx valid after mmc1_clk rising clock edge	2.3		1.9		ns
MMC/SD/SDIO Interface 2							
HSSD3	$t_{su}(CMDV-CLKIH)$	Setup time, mmc2_cmd valid before mmc2_clk rising clock edge	5.6		26		ns
HSSD4	$t_{su}(CLKIH-CMDIV)$	Hold time, mmc2_cmd valid after mmc2_clk rising clock edge	2.3		1.9		ns
HSSD7	$t_{su}(DATxV-CLKIH)$	Setup time, mmc2_datx valid before mmc2_clk rising clock edge	5.6		26		ns
HSSD8	$t_{su}(CLKIH-DATxIV)$	Hold time, mmc2_datx valid after mmc2_clk rising clock edge	2.3		1.9		ns
MMC/SD/SDIO Interface 3							
HSSD3	$t_{su}(CMDV-CLKIH)$	Setup time, mmc3_cmd valid before mmc3_clk rising clock edge	5.6		26		ns
HSSD4	$t_{su}(CLKIH-CMDIV)$	Hold time, mmc3_cmd valid after mmc3_clk rising clock edge	2.3		1.9		ns
HSSD7	$t_{su}(DATxV-CLKIH)$	Setup time, mmc3_datx valid before mmc3_clk rising clock edge	5.6		26		ns
HSSD8	$t_{su}(CLKIH-DATxIV)$	Hold time, mmc3_datx valid after mmc3_clk rising clock edge	2.3		1.9		ns

(1) Timing Parameters are referred to output clock specified in [Table 6-119](#).

(2) The timing requirements are assured for the cycle jitter and duty cycle error conditions specified in [Table 6-119](#).

(3) In datx, x is equal to 1, 2, 3, 4, 5, 6, or 7.

Table 6-119. MMC/SD/SDIO Switching Characteristics – High-Speed SD Mode

NO.	PARAMETER		1.15 V		1.0 V		UNIT
			MIN	MAX	MIN	MAX	
High-Speed SD Mode							
HSSD1	$t_{c}(clk)$	Cycle time ⁽¹⁾ , output clk period	20.8		41.7		ns
HSSD2	$t_{W}(clkH)$	Typical pulse duration, output clk high	$X^{(5)} \cdot PO^{(2)}$		$X^{(5)} \cdot PO^{(2)}$		ns
HSSD2	$t_{W}(clkL)$	Typical pulse duration, output clk low	$Y^{(6)} \cdot PO^{(2)}$		$Y^{(6)} \cdot PO^{(2)}$		ns
	$t_{dc}(clk)$	Duty cycle error, output clk		1041.7		2083.3	ps
	$t_{j}(clk)$	Jitter standard deviation ⁽³⁾ , output clk		200		200	ps

Table 6-119. MMC/SD/SDIO Switching Characteristics – High-Speed SD Mode (continued)

NO.	PARAMETER		1.15 V		1.0 V		UNIT
			MIN	MAX	MIN	MAX	
MMC/SD/SDIO Interface 1 (1.8 V IO)							
	$t_{c(\text{clk})}$	Rise time, output clk		3		3	ns
	$t_{W(\text{clkH})}$	Fall time, output clk		3		3	ns
	$t_{W(\text{clkL})}$	Rise time, output data		3		3	ns
	$t_{dc(\text{clk})}$	Fall time, output data		3		3	ns
HSSD5	$t_{d(\text{CLKOH-CMD})}$	Delay time, mmc1_clk rising clock edge to mmc1_cmd transition	3.7	14.1	4.1	34.5	ns
HSSD6	$t_{d(\text{CLKOH-DATx})}$	Delay time, mmc1_clk rising clock edge to mmc1_datx transition	3.7	14.1	4.1	34.5	ns
MMC/SD/SDIO Interface 1 (3.0 V IO)							
	$t_{c(\text{clk})}$	Rise time, output clk		3		3	ns
	$t_{W(\text{clkH})}$	Fall time, output clk		3		3	ns
	$t_{W(\text{clkL})}$	Rise time, output data		3		3	ns
	$t_{dc(\text{clk})}$	Fall time, output data		3		3	ns
HSSD5	$t_{d(\text{CLKOH-CMD})}$	Delay time, mmc1_clk rising clock edge to mmc1_cmd transition	3.7	14.1	4.1	34.5	ns
HSSD6	$t_{d(\text{CLKOH-DATx})}$	Delay time, mmc1_clk rising clock edge to mmc1_datx transition	3.7	14.1	4.1	34.5	ns
MMC/SD/SDIO Interface 2							
	$t_{c(\text{clk})}$	Rise time, output clk		3		3	ns
	$t_{W(\text{clkH})}$	Fall time, output clk		3		3	ns
	$t_{W(\text{clkL})}$	Rise time, output data		3		3	ns
	$t_{dc(\text{clk})}$	Fall time, output data		3		3	ns
HSSD5	$t_{d(\text{CLKOH-CMD})}$	Delay time, mmc2_clk rising clock edge to mmc2_cmd transition	3.7	14.1	4.1	34.5	ns
HSSD6	$t_{d(\text{CLKOH-DATx})}$	Delay time, mmc2_clk rising clock edge to mmc2_datx transition	3.7	14.1	4.1	34.5	ns
MMC/SD/SDIO Interface 3							
	$t_{c(\text{clk})}$	Rise time, output clk		3		3	ns
	$t_{W(\text{clkH})}$	Fall time, output clk		3		3	ns
	$t_{W(\text{clkL})}$	Rise time, output data		3		3	ns
	$t_{dc(\text{clk})}$	Fall time, output data		3		3	ns
HSSD5	$t_{d(\text{CLKOH-CMD})}$	Delay time, mmc3_clk rising clock edge to mmc3_cmd transition	3.7	14.1	4.1	34.5	ns
HSSD6	$t_{d(\text{CLKOH-DATx})}$	Delay time, mmc3_clk rising clock edge to mmc3_datx transition	3.7	14.1	4.1	34.5	ns

PRODUCT PREVIEW

- (1) Related with the output clk maximum and minimum frequencies programmable in I/F module.
- (2) PO = output clk period in ns.
- (3) The jitter probability density can be approximated by a Gaussian function.
- (4) In datx, x is equal to 1, 2, 3, 4, 5, 6, or 7.
- (5) The X parameter is defined as follows.

CLKD	X
1 or Even	0.5
Odd	$(\text{trunk}[\text{CLKD}/2]+1)/\text{CLKD}$

For details about clock division factor CLKD, see the *OMAP35xx ES2.0 Technical Reference Manual (TRM)* [literature number [SPRUF98](#)].

- (6) The Y parameter is defined as follows.

CLKD	Y
1 or Even	0.5
Odd	$(\text{trunk}[\text{CLKD}/2])/\text{CLKD}$

For details about clock division factor CLKD, see the *OMAP35xx ES2.0 Technical Reference Manual (TRM)* [literature number [SPRUF98](#)].

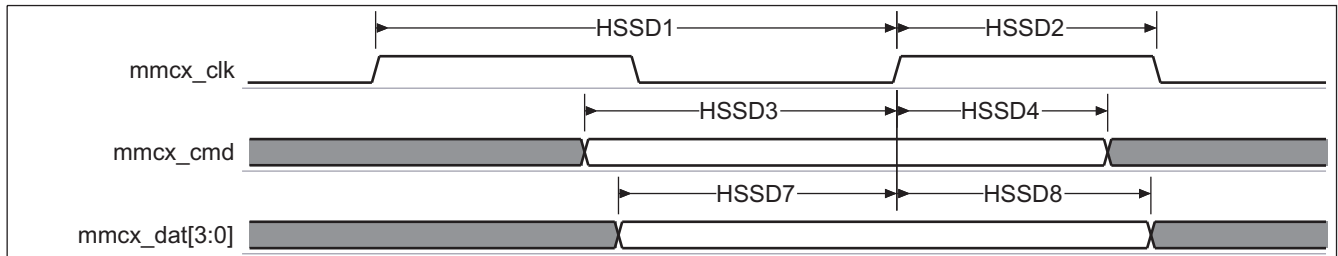

030-106

In mmc_x, x is equal to 1, 2, or 3.

Figure 6-59. MMC/SD/SDIO – High-Speed SD Mode – Data/Command Receive

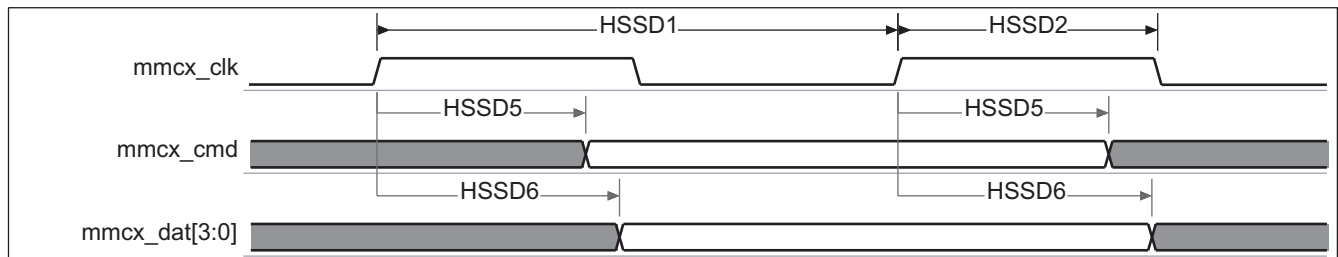

030-107

In mmc_x, x is equal to 1, 2, or 3.

Figure 6-60. MMC/SD/SDIO – High-Speed SD Mode – Data/Command Transmit

6.7.1.5 MMC/SD/SDIO in Standard SD Mode

[Table 6-121](#) and [Table 6-122](#) assume testing over the recommended operating conditions and electrical characteristic conditions (see [Figure 6-61](#)).

Table 6-120. MMC/SD/SDIO Timing Conditions – Standard SD Mode

TIMING CONDITION PARAMETER		VALUE	UNIT
Standard SD Mode			
Input Conditions			
t_R	Input signal rise time	10	ns
t_F	Input signal fall time	10	ns
Output Conditions			
C_{LOAD}	Output load capacitance	40	pF

Table 6-121. MMC/SD/SDIO Timing Requirements – Standard SD Mode⁽¹⁾⁽²⁾⁽³⁾

NO.	PARAMETER		1.15 V		1.0 V		UNIT
			MIN	MAX	MIN	MAX	
Standard SD Mode							
MMC/SD/SDIO Interface 1 (1.8 V IO)							
SD3	$t_{su}(CMDV-CLKIH)$	Setup time, mmc1_cmd valid before mmc1_clk rising clock edge	6.2		47.7		ns
SD4	$t_{su}(CLKIH-CMDIV)$	Hold time, mmc1_cmd valid after mmc1_clk rising clock edge	19.4		19.2		ns
SD7	$t_{su}(DATxV-CLKIH)$	Setup time, mmc1_datx valid before mmc1_clk rising clock edge	6.2		47.7		ns
SD8	$t_{su}(CLKIH-DATxIV)$	Hold time, mmc1_datx valid after mmc1_clk rising clock edge	19.4		19.2		ns
MMC/SD/SDIO Interface 1 (3.0 V IO)							
SD3	$t_{su}(CMDV-CLKIH)$	Setup time, mmc1_cmd valid before mmc1_clk rising clock edge	6.2		47.7		ns
SD4	$t_{su}(CLKIH-CMDIV)$	Hold time, mmc1_cmd valid after mmc1_clk rising clock edge	19.4		19.2		ns
SD7	$t_{su}(DATxV-CLKIH)$	Setup time, mmc1_datx valid before mmc1_clk rising clock edge	6.2		47.7		ns
SD8	$t_{su}(CLKIH-DATxIV)$	Hold time, mmc1_datx valid after mmc1_clk rising clock edge	19.4		19.2		ns
MMC/SD/SDIO Interface 2							
SD3	$t_{su}(CMDV-CLKIH)$	Setup time, mmc2_cmd valid before mmc2_clk rising clock edge	6.2		47.7		ns
SD4	$t_{su}(CLKIH-CMDIV)$	Hold time, mmc2_cmd valid after mmc2_clk rising clock edge	19.4		19.2		ns
SD7	$t_{su}(DATxV-CLKIH)$	Setup time, mmc2_datx valid before mmc2_clk rising clock edge	6.2		47.7		ns
SD8	$t_{su}(CLKIH-DATxIV)$	Hold time, mmc2_datx valid after mmc2_clk rising clock edge	19.4		19.2		ns
MMC/SD/SDIO Interface 3							
SD3	$t_{su}(CMDV-CLKIH)$	Setup time, mmc3_cmd valid before mmc3_clk rising clock edge	6.2		47.7		ns
SD4	$t_{su}(CLKIH-CMDIV)$	Hold time, mmc3_cmd valid after mmc3_clk rising clock edge	19.4		19.2		ns
SD7	$t_{su}(DATxV-CLKIH)$	Setup time, mmc3_datx valid before mmc3_clk rising clock edge	6.2		47.7		ns
SD8	$t_{su}(CLKIH-DATxIV)$	Hold time, mmc3_datx valid after mmc3_clk rising clock edge	19.4		19.2		ns

(1) Timing parameters are referred to output clock specified in [Table 6-122](#).

(2) The timing requirements are assured for the cycle jitter and duty cycle error conditions specified in [Table 6-122](#).

(3) In datx, x is equal to 1, 2, 3, 4, 5, 6, or 7.

Table 6-122. MMC/SD/SDIO Switching Characteristics – Standard SD Mode

NO.	PARAMETER		1.15 V		1.0 V		UNIT
			MIN	MAX	MIN	MAX	
Standard SD Mode							
SD1	$t_{c}(clk)$	Cycle time ⁽¹⁾ , output clk period	41.7		83.3		ns
SD2	$t_{W}(clkH)$	Typical pulse duration, output clk high	$X^{(5)} \cdot PO^{(2)}$		$X^{(5)} \cdot PO^{(2)}$		ns
SD2	$t_{W}(clkL)$	Typical pulse duration, output clk low	$Y^{(6)} \cdot PO^{(2)}$		$Y^{(6)} \cdot PO^{(2)}$		ns
	$t_{dc}(clk)$	Duty cycle error, output clk		2083.3		4166.7	ps
	$t_{j}(clk)$	Jitter standard deviation ⁽³⁾ , output clk		200		200	ps
MMC/SD/SDIO Interface 1 (1.8 V IO)							

Table 6-122. MMC/SD/SDIO Switching Characteristics – Standard SD Mode (continued)

NO.	PARAMETER		1.15 V		1.0 V		UNIT
			MIN	MAX	MIN	MAX	
	$t_{c(\text{clk})}$	Rise time, output clk		10		10	ns
	$t_{W(\text{clkH})}$	Fall time, output clk		10		10	ns
	$t_{W(\text{clkL})}$	Rise time, output data		10		10	ns
	$t_{dc(\text{clk})}$	Fall time, output data		10		10	ns
SD5	$t_{d(\text{CLKOH-CMD})}$	Delay time, mmc1_clk rising clock edge to mmc1_cmd transition	6.1	35.5	6.3	77	ns
SD6	$t_{d(\text{CLKOH-DATx})}$	Delay time, mmc1_clk rising clock edge to mmc1_datx transition	6.1	35.5	6.3	77	ns
MMC/SD/SDIO Interface 1 (3.0 V IO)							
	$t_{c(\text{clk})}$	Rise time, output clk		10		10	ns
	$t_{W(\text{clkH})}$	Fall time, output clk		10		10	ns
	$t_{W(\text{clkL})}$	Rise time, output data		10		10	ns
	$t_{dc(\text{clk})}$	Fall time, output data		10		10	ns
SD5	$t_{d(\text{CLKOH-CMD})}$	Delay time, mmc1_clk rising clock edge to mmc1_cmd transition	6.1	35.5	6.3	77	ns
SD6	$t_{d(\text{CLKOH-DATx})}$	Delay time, mmc1_clk rising clock edge to mmc1_datx transition	6.1	35.5	6.3	77	ns
MMC/SD/SDIO Interface 2							
	$t_{c(\text{clk})}$	Rise time, output clk		10		10	ns
	$t_{W(\text{clkH})}$	Fall time, output clk		10		10	ns
	$t_{W(\text{clkL})}$	Rise time, output data		10		10	ns
	$t_{dc(\text{clk})}$	Fall time, output data		10		10	ns
SD5	$t_{d(\text{CLKOH-CMD})}$	Delay time, mmc2_clk rising clock edge to mmc2_cmd transition	6.1	35.5	6.3	77	ns
SD6	$t_{d(\text{CLKOH-DATx})}$	Delay time, mmc2_clk rising clock edge to mmc2_datx transition	6.1	35.5	6.3	77	ns
MMC/SD/SDIO Interface 3							
	$t_{c(\text{clk})}$	Rise time, output clk		10		10	ns
	$t_{W(\text{clkH})}$	Fall time, output clk		10		10	ns
	$t_{W(\text{clkL})}$	Rise time, output data		10		10	ns
	$t_{dc(\text{clk})}$	Fall time, output data		10		10	ns
SD5	$t_{d(\text{CLKOH-CMD})}$	Delay time, mmc3_clk rising clock edge to mmc3_cmd transition	6.1	35.5	6.3	77	ns
SD6	$t_{d(\text{CLKOH-DATx})}$	Delay time, mmc3_clk rising clock edge to mmc3_datx transition	6.1	35.5	6.3	77	ns

- (1) Related with the output clk maximum and minimum frequencies programmable in I/F module.
- (2) PO = output clk period in ns.
- (3) The jitter probability density can be approximated by a Gaussian function.
- (4) In datx, x is equal to 1, 2, 3, 4, 5, 6, or 7.
- (5) The X parameter is defined as follows.

CLKD	X
1 or Even	0.5
Odd	$(\text{trunk}[\text{CLKD}/2]+1)/\text{CLKD}$

For details about clock division factor CLKD, see the *OMAP35xx ES2.0 Technical Reference Manual (TRM)* [literature number [SPRUF98](#)].

- (6) The Y parameter is defined as follows.

CLKD	Y
1 or Even	0.5
Odd	$(\text{trunk}[\text{CLKD}/2])/\text{CLKD}$

For details about clock division factor CLKD, see the *OMAP35xx ES2.0 Technical Reference Manual (TRM)* [literature number [SPRUF98](#)].

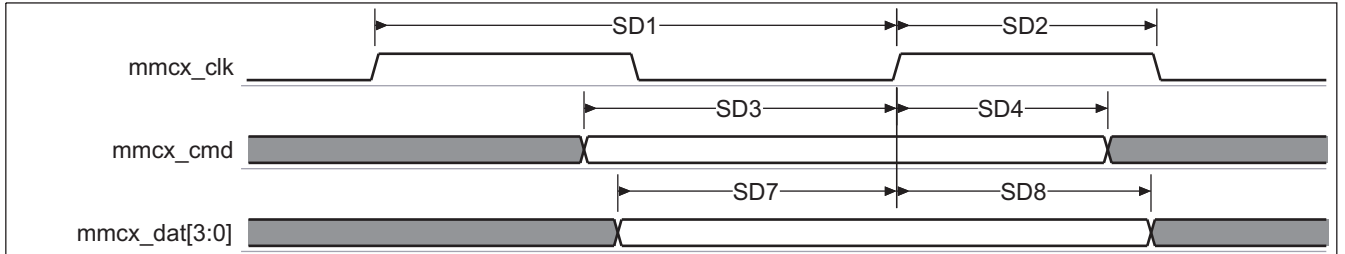

In mmc_x, x is equal to 1, 2, or 3.

Figure 6-61. MMC/SD/SDIO – Standard SD Mode – Data/Command Receive

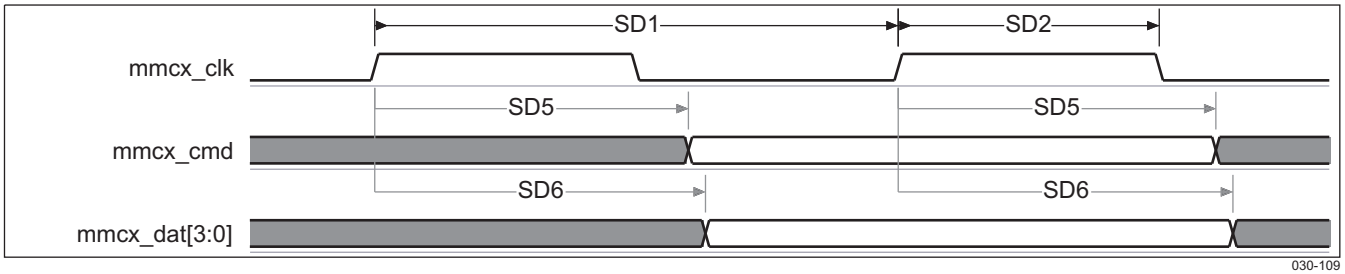

In mmc_x, x is equal to 1, 2, or 3.

Figure 6-62. MMC/SD/SDIO – Standard SD Mode – Data/Command Transmit

PRODUCT PREVIEW

6.8 Test Interfaces

The emulation and trace interfaces allow tracing activities of the following CPUs:

- ARM1136JF-STM through an Embedded Trace Macro-cell (ETM11) dedicated to enable real-time trace of the ARM subsystem operations and a Serial Debug Trace Interface (SDTI)

All processors can be emulated via JTAG ports.

6.8.1 Embedded Trace Macro Interface (ETM)

Table 6-123 assumes testing over the recommended operating conditions (see Figure 6-63).

Table 6-123. Embedded Trace Macro Interface Switching Characteristics⁽¹⁾

NO.	PARAMETER		1.15 V		UNIT
			MIN	MAX	
f	$1/t_{c(\text{CLK})}$	Frequency, etk_clk		166	MHz
ETM0	$t_{c(\text{CLK})}$	Cycle time ⁽²⁾ , etk_clk	6		ns
ETM1	$t_{W(\text{CLK})}$	Clock pulse width, etk_clk	2.7		ns
ETM2	$t_{d(\text{CLK-CTL})}$	Delay time, etk_clk clock edge to etk_ctl transition	-0.5	0.5	ns
ETM3	$t_{d(\text{CLK-D})}$	Delay time, etk_clk clock high to etk_d[15:0] transition	-0.5	0.5	ns

(1) The capacitive load is equivalent to 25 pF.

(2) Cycle time is given by considering a jitter of 5%.

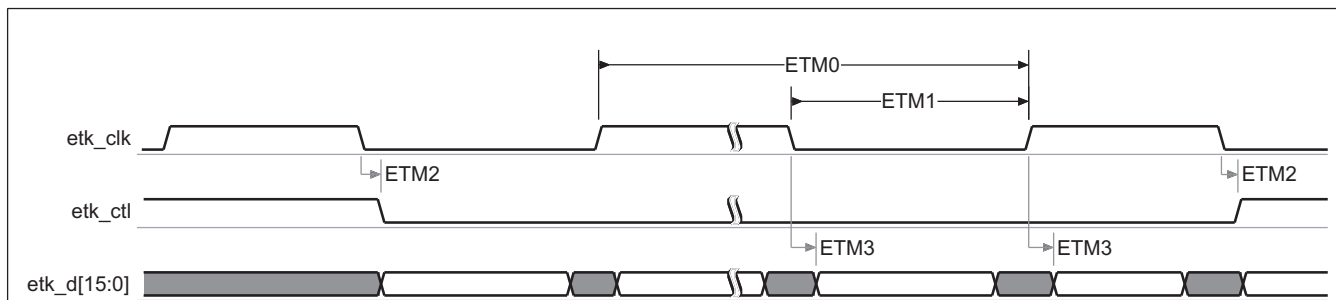

030-110

Figure 6-63. Embedded Trace Macro Interface

6.8.2 System Debug Trace Interface (SDTI)

The system debug trace interface (SDTI) module provides real-time software tracing functionality to the OMAP3515/03 device.

The trace interface has four trace data pins and a trace clock pin.

This interface is a dual-edge interface: the data are available on rising and falling edges of sdti_clk but can be also configured in single edge mode where data are available on falling edge of sdti_clk.

Serial interface operates in clock stop regime: serial clock is not free running, when there is no trace data there is no trace clock.

6.8.2.1 System Debug Trace Interface in Dual-Edge Mode

Table 6-125 assumes testing over the recommended operating conditions and electrical characteristic conditions (see Figure 6-64).

Table 6-124. System Debug Trace Interface Timing Conditions – Dual-Edge Mode

TIMING CONDITION PARAMETER		VALUE	UNIT
Output Conditions			
C_{LOAD}	Output load capacitance	25	pF

Table 6-125. System Debug Trace Interface Switching Characteristics – Dual-Edge Mode

NO.	PARAMETER		1.15 V		1.0 V		UNIT
			MIN	MAX	MIN	MAX	
SD1	$t_{c(CLK)}$	Cycle time, sdti_clk period	29		29		ns
SD2	$t_{w(CLK)}$	Typical pulse duration, sdti_clk high or low	0.5*P ⁽¹⁾		0.5*P ⁽¹⁾		ns
	$t_{dc(CLK)}$	Duty cycle error, sdti_clk	-1.2	1.2	-1.2	1.2	ns
	$t_{R(CLK)}$	Rise time, sdti_clk		5		5	ns
	$t_{F(CLK)}$	Fall time, sdti_clk		5		5	ns
SD3	$t_{d(CLK-TxD)}$	Multiplexing mode on etk pins	2.3	10.9	2.3	10.9	ns
		Multiplexing mode on jtag_emu pins	2.3	13.9	2.3	13.9	
	$t_{R(CLK)}$	Rise time, sdti_txd[3:0]		5		5	ns
	$t_{F(CLK)}$	Fall time, sdti_txd[3:0]		5		5	ns

(1) P = sdti_clk clock period

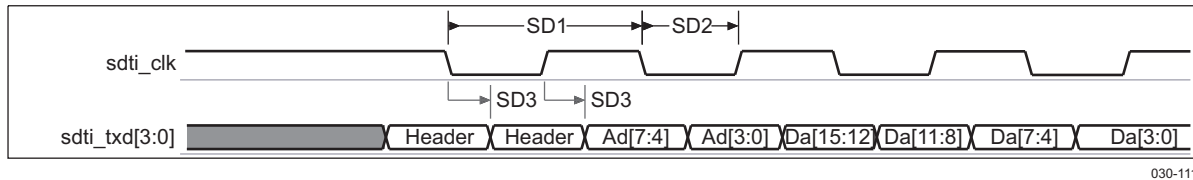

030-111

Figure 6-64. System Debug Trace Interface – Dual-Edge Mode

6.8.2.2 System Debug Trace Interface in Single-Edge Mode

Table 6-127 assumes testing over the recommended operating conditions and electrical characteristic conditions (see Figure 6-65).

Table 6-126. System Debug Trace Interface Timing Conditions – Single-Edge Mode

TIMING CONDITION PARAMETER		VALUE	UNIT
Output Conditions			
C_{LOAD}	Output load capacitance	25	pF

Table 6-127. System Debug Trace Interface Switching Characteristics – Single-Edge Mode

NO.	PARAMETER		1.15 V		1.0 V		UNIT
			MIN	MAX	MIN	MAX	
SD1	$t_{c(CLK)}$	Cycle time, sdti_clk period	29		29		ns
SD2	$t_{w(CLK)}$	Typical pulse duration, sdti_clk high or low	0.5*P ⁽¹⁾		0.5*P ⁽¹⁾		ns
	$t_{dc(CLK)}$	Duty cycle error, sdti_clk	-1.2	1.2	-1.2	1.2	ns
	$t_{R(CLK)}$	Rise time, sdti_clk		5		5	ns
	$t_{F(CLK)}$	Fall time, sdti_clk		5		5	ns
SD3	$t_{d(CLK-TxD)}$	Multiplexing mode on etk pins	2.3	26.5	2.3	26.5	ns
		Multiplexing mode on jtag_emu pins	2.3	33.2	2.3	33.2	
	$t_{R(CLK)}$	Rise time, sdti_txd[3:0]		5		5	ns

Table 6-127. System Debug Trace Interface Switching Characteristics – Single-Edge Mode (continued)

NO.	PARAMETER		1.15 V		1.0 V		UNIT
			MIN	MAX	MIN	MAX	
	$t_{F(CLK)}$	Fall time, $sdti_txd[3:0]$		5		5	ns

(1) P = $sdti_clk$ clock period.

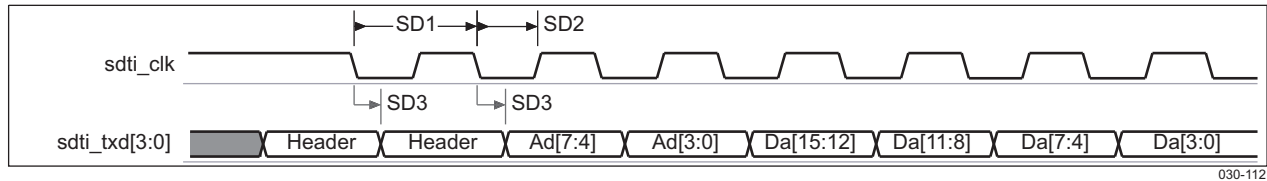

Figure 6-65. System Debug Trace Interface – Single-Edge Mode

6.8.3 JTAG Interfaces

OMAP3515/03 JTAG TAP controller handles standard IEEE JTAG interfaces. The following sections define the timing requirements for several tools used to test the OMAP3515/03 processors as:

- Free running clock tool, like XDS560 and XDS510 tools
- Adaptive clock tool, like RealView® ICE tool and Lauterbach™ tool

6.8.3.1 JTAG – Free Running Clock Mode

Table 6-129 and Table 6-130 assume testing over the recommended operating conditions and electrical characteristic conditions (see Figure 6-66).

Table 6-128. JTAG Timing Conditions – Free Running Clock Mode

TIMING CONDITION PARAMETER		VALUE	UNIT
Input Conditions			
t_R	Input signal rise time	5	ns
t_F	Input signal fall time	5	ns
Output Conditions			
C_{LOAD}	Output load capacitance	30	pF

Table 6-129. JTAG Timing Requirements – Free Running Clock Mode⁽⁵⁾

NO.	PARAMETER		1.15 V		1.0 V		UNIT
			MIN	MAX	MIN	MAX	
JT4	$t_{c(tck)}$	Cycle time ⁽¹⁾ , $jtag_tck$ period	25		33		ns
JT5	$t_{w(tckL)}$	Typical pulse duration, $jtag_tck$ low	0.5*P ⁽²⁾		0.5*P ⁽²⁾		ns
JT6	$t_{w(tckH)}$	Typical pulse duration, $jtag_tck$ high	0.5*P ⁽²⁾		0.5*P ⁽²⁾		ns
	$t_{dc(tck)}$	Duty cycle error, $jtag_tck$	-1250	1250	-1667	1667	ps
	$t_{j(tck)}$	Cycle jitter ⁽³⁾ , $jtag_tck$	-1250	1250	-1667	1667	ps
JT7	$t_{su(tdiV-rtckH)}$	Setup time, $jtag_tdi$ valid before $jtag_rtck$ high	1.8		1.8		ns
JT8	$t_{h(tdiV-rtckH)}$	Hold time, $jtag_tdi$ valid after $jtag_rtck$ high	0.7		1		ns
JT9	$t_{su(tmsV-rtckH)}$	Setup time, $jtag_tms$ valid before $jtag_rtck$ high	1.8		1.8		ns
JT10	$t_{h(tmsV-rtckH)}$	Hold time, $jtag_tms$ valid after $jtag_rtck$ high	0.7		1		ns
JT12	$t_{su(emuxV-rtckH)}$	Setup time, $jtag_emux$ ⁽⁴⁾ valid before $jtag_rtck$ high	14.6		19.8		ns
JT13	$t_{h(emuxV-rtckH)}$	Hold time, $jtag_emux$ ⁽⁴⁾ valid after $jtag_rtck$ high	2		2.7		ns

(1) Related with the input maximum frequency supported by the JTAG module.

(2) P = $jtag_tck$ period in ns.

(3) Maximum cycle jitter supported by $jtag_tck$ input clock.

(4) $x = 0$ to 1

(5) The timing requirements are assured for the cycle jitter and duty cycle error conditions specified.

Table 6-130. JTAG Switching Characteristics – Free Running Clock Mode

NO.	PARAMETER		1.15 V		1.0 V		UNIT
			MIN	MAX	MIN	MAX	
JT1	$t_{c(rtck)}$	Cycle time ⁽¹⁾ , jtag_rtck period	25		33		ns
JT2	$t_w(rtckL)$	Typical pulse duration, jtag_rtck low	0.5*PO ⁽²⁾		0.5*PO ⁽²⁾		ns
JT3	$t_w(rtckH)$	Typical pulse duration, jtag_rtck high	0.5*PO ⁽²⁾		0.5*PO ⁽²⁾		ns
	$t_{dc(rtck)}$	Duty cycle error, jtag_rtck	-1250	1250	-1667	1667	ps
	$t_j(rtck)$	Jitter standard deviation ⁽³⁾ , jtag_rtck		33.3		33.3	ps
	$t_R(rtck)$	Rise time, jtag_rtck		4		4	ns
	$t_F(rtck)$	Fall time, jtag_rtck		4		4	ns
JT11	$t_d(rtckL\text{-}tdoV)$	Delay time, jtag_rtck low to jtag_tdo valid	-5.8	5.8	-7.9	7.9	ns
	$t_R(tdo)$	Rise time, jtag_tdo		4		4	ns
	$t_F(tdo)$	Fall time, jtag_tdo		4		4	ns
JT14	$t_d(rtckH\text{-}emuxV)$	Delay time, jtag_rtck high to ,jtag_emux ⁽⁴⁾ valid	2.7	15.1	2.7	20.4	ns
	$t_R(emux)$	Rise time, jtag_emux ⁽⁴⁾		6		6	ns
	$t_F(emux)$	Fall time, jtag_emux ⁽⁴⁾		6		6	ns

(1) Related with the jtag_rtck maximum frequency.

(2) PO = jtag _rtck period in ns.

(3) The jitter probability density can be approximated by a Gaussian function.

(4) $x = 0$ to 1

PRODUCT PREVIEW

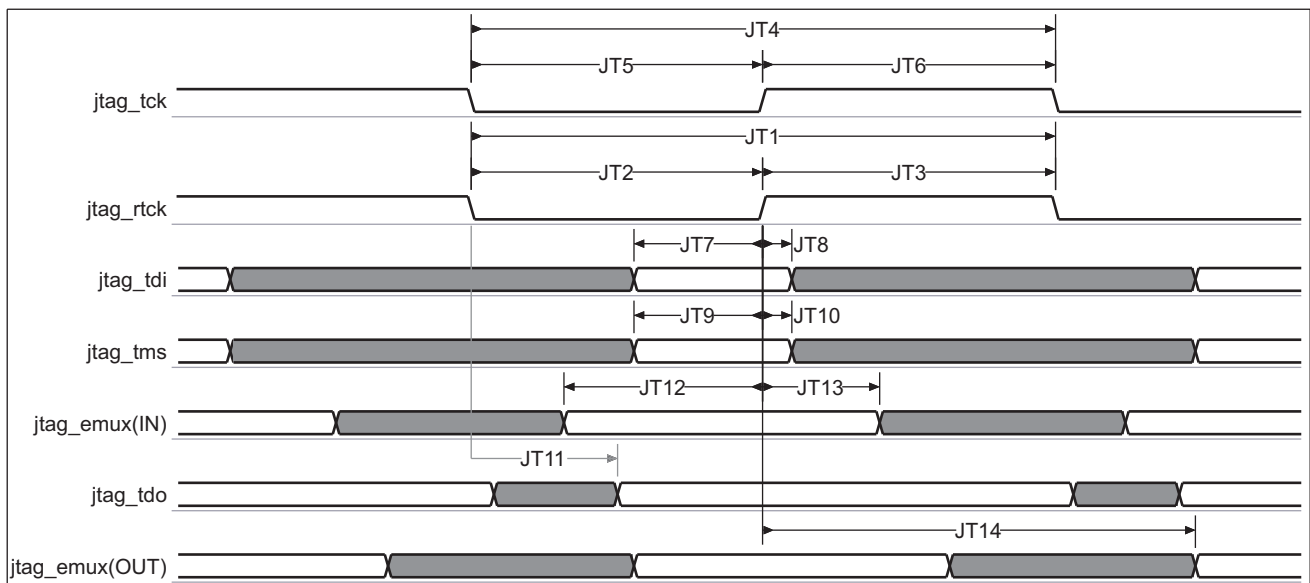

030-113

In jtag_emux, x is equal to 0 to 1.

Figure 6-66. JTAG Interface Timing – Free Running Clock Mode

6.8.3.2 JTAG – Adaptive Clock Mode

Table 6-132 and Table 6-133 assume testing over the recommended operating conditions and electrical characteristic conditions (see Figure 6-67):

Table 6-131. JTAG Timing Conditions – Adaptive Clock Mode

TIMING CONDITION PARAMETER		VALUE	UNIT
Input Conditions			
t_R	Input signal rise time	5	ns
t_F	Input signal fall time	5	ns
Output Conditions			
C_{LOAD}	Output load capacitance	30	pF

Table 6-132. JTAG Timing Requirements – Adaptive Clock Mode⁽⁴⁾

NO.	PARAMETER		1.15 V		1.0 V		UNIT
			MIN	MAX	MIN	MAX	
JA4	$t_{c(tck)}$	Cycle time ⁽¹⁾ , jtag_tck period	50		50		ns
JA5	$t_{w(tckL)}$	Typical pulse duration, jtag_tck low	0.5*P ⁽²⁾		0.5*P ⁽²⁾		ns
JA6	$t_{w(tckH)}$	Typical pulse duration, jtag_tck high	0.5*P ⁽²⁾		0.5*P ⁽²⁾		ns
	$t_{dc(lclk)}$	Duty cycle error, jtag_tck	-2500	2500	-2500	2500	ps
	$t_{j(lclk)}$	Cycle jitter ⁽³⁾ , jtag_tck	-1500	1500	-1500	1500	ps
JA7	$t_{su(tdiV-tckH)}$	Setup time, jtag_tdi valid before jtag_tck high	13.8		13.8		ns
JA8	$t_{h(tdiV-tckH)}$	Hold time, jtag_tdi valid after jtag_tck high	13.8		13.8		ns
JA9	$t_{su(tmsV-tckH)}$	Setup time, jtag_tms valid before jtag_tck high	13.8		13.8		ns
JA10	$t_{h(tmsV-tckH)}$	Hold time, jtag_tms valid after jtag_tck high	13.8		13.8		ns

(1) Related with the input maximum frequency supported by the JTAG module.

(2) P = jtag_tck period in ns.

(3) Maximum cycle jitter supported by jtag_tck input clock.

(4) The timing requirements are assured for the cycle jitter and duty cycle error conditions specified.

Table 6-133. JTAG Switching Characteristics – Adaptive Clock Mode

NO.	PARAMETER		1.15 V		1.0 V		UNIT
			MIN	MAX	MIN	MAX	
JA1	$t_{c(rtck)}$	Cycle time ⁽¹⁾ , jtag_rtck period	50		50		ns
JA2	$t_{w(rtckL)}$	Typical pulse duration, jtag_rtck low	0.5*PO ⁽²⁾		0.5*PO ⁽²⁾		ns
JA3	$t_{w(rtckH)}$	Typical pulse duration, jtag_rtck high	0.5*PO ⁽²⁾		0.5*PO ⁽²⁾		ns
	$t_{dc(rtck)}$	Duty cycle error, jtag_rtck	-2500	2500	-2500	2500	ps
	$t_{j(rtck)}$	Jitter standard deviation ⁽³⁾ , jtag_rtck		33.3		33.3	ps
	$t_R(rtck)$	Rise time, jtag_rtck		4		4	ns
	$t_F(rtck)$	Fall time, jtag_rtck		4		4	ns
JA11	$t_{d(rtckL-tdoV)}$	Delay time, jtag_rtck low to jtag_tdo valid	-14.6	14.6	-14.6	14.6	ns
	$t_R(tdo)$	Rise time, jtag_tdo,		4		4	ns
	$t_F(tdo)$	Fall time, jtag_tdo		4		4	ns

(1) Related with the jtag_rtck maximum frequency programmable.

(2) PO = jtag_rtck period in ns.

(3) The jitter probability density can be approximated by a Gaussian function.



030-114

Figure 6-67. JTAG Interface Timing – Adaptive Clock Mode

PRODUCT PREVIEW

7 PACKAGE CHARACTERISTICS

7.1 Package Thermal Resistance

Table 7-1 provides the thermal resistance characteristics for the recommended package types used on the OMAP3515/03 Applications Processor.

Table 7-1. OMAP3515/03 Thermal Resistance Characteristics ⁽³⁾

Package	Power (W)	R _{θJA} (°C/W)	R _{θJB} (°C/W)	R _{θJC} (°C/W)	Board Type
OMAP3515/03 (CBB Pkg.)	TBD	24.46	10.94	0.01	2S2P ⁽¹⁾
OMAP35 15/03 (CUS Pkg.)	TBD	TBD	TBD	TBD	TBD

(1) The board types are defined by JEDEC (reference JEDEC standard JESD51-9, Test Board for Area Array Surface Mount Package Thermal Measurements).

(2) Not applicable since the POP package has a memory package on top, no heat sink can be used. (TBD)

(3) R_{θJA} (Theta-JA) = Thermal Resistance Junction-to-Ambient, °C/W
 R_{θJB} (Theta-JB) = Thermal Resistance Junction-to-Board, °C/W
 R_{θJC} (Theta-JC) = Thermal Resistance Junction-to-Case, °C/W

7.2 Device Support

7.2.1 Development Support (TBD)

7.2.2 Device and Development-Support Tool Nomenclature

To designate the stages in the product development cycle, TI assigns prefixes to the part numbers of all OMAP™ processors and support tools. Each commercial OMAP platform member has one of three prefixes: X, P, or null (no prefix). Texas Instruments recommends two of three possible prefix designators for its support tools: TMDX and TMDS. These prefixes represent evolutionary stages of product development from engineering prototypes (TMDX) through fully qualified production devices/tools (TMDS).

Device development evolutionary flow:

- X** Experimental device that is not necessarily representative of the final device's electrical specifications and may not use production assembly flow. (TMX definition)
- P** Prototype device that is not necessarily the final silicon die and may not necessarily meet final electrical specifications. (TMP definition)
- null** Production version of the silicon die that is fully qualified. (TMS definition)

Support tool development evolutionary flow:

- TMDX** Development support product that has not yet completed Texas Instruments internal qualification testing.
- TMDS** Fully qualified development support product.

TMX and TMP devices and TMDX development-support tools are shipped against the following disclaimer:

“Developmental product is intended for internal evaluation purposes.”

Production devices and TMDS development-support tools have been characterized fully, and the quality and reliability of the device have been demonstrated fully. TI's standard warranty applies.

Predictions show that prototype devices (X or P), have a greater failure rate than the standard production devices. Texas Instruments recommends that these devices not be used in any production system because their expected end-use failure rate still is undefined. Only qualified production devices are to be used.

For additional description of the device nomenclature markings, see the *OMAP35xx Applications Processor Silicon Errata* (literature number [SPRZ278](#)).

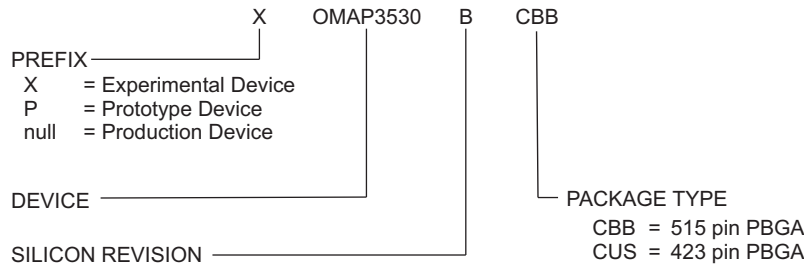

Figure 7-1. Device Nomenclature

7.2.3 Documentation Support

7.2.3.1 Related Documentation from Texas Instruments

The following documents describe the OMAP3515/03 Applications Processor. Copies of these documents are available on the Internet at www.ti.com. Tip: Enter the literature number in the search box provided at www.ti.com.

The current documentation that describes the OMAP3515/03 Applications Processor, related peripherals, and other technical collateral, is available in the TBD product folder at: www.ti.com/tbd.

[SPRUF98](#) *OMAP35xx Technical Reference Manual.* Collection of documents providing detailed information on the OMAP3 architecture including power, reset, and clock control, interrupts, memory map, and switch fabric interconnect. Detailed information on the microprocessor unit (MPU) subsystem, the image, video, and audio (IVA2.2) subsystem, as well a functional description of the peripherals supported on OMAP35xx devices is also included.

[SPRU889](#) *High-Speed DSP Systems Design Reference Guide.* Provides recommendations for meeting the many challenges of high-speed DSP system design. These recommendations include information about DSP audio, video, and communications systems for the C5000 and C6000 DSP platforms.

7.2.3.2 Related Documentation from Other Sources

The following documents are related to the OMAP3515/03 Applications Processor. Copies of these documents can be obtained directly from the internet or from your Texas Instruments representative.

Cortex™-A8 Technical Reference Manual. This is the technical reference manual for the Cortex-A8 processor. A copy of this document can be obtained via the internet at <http://infocenter.arm.com>. Please see the *OMAP35xx Applications Processor Silicon Errata* (literature number [SPRZ278](#)) to determine the revision of the Cortex-A8 core used on your device.

ARM Core Cortex™-A8 (AT400/AT401) Errata Notice. Provides a list of advisories for the different revisions of the Cortex-A8 processor. Contact your TI representative for a copy of this document. Please see the *OMAP35xx Applications Processor Silicon Errata* (literature number [SPRZ278](#)) to determine the revision of the Cortex-A8 core used on your device.

IMPORTANT NOTICE

Texas Instruments Incorporated and its subsidiaries (TI) reserve the right to make corrections, modifications, enhancements, improvements, and other changes to its products and services at any time and to discontinue any product or service without notice. Customers should obtain the latest relevant information before placing orders and should verify that such information is current and complete. All products are sold subject to TI's terms and conditions of sale supplied at the time of order acknowledgment.

TI warrants performance of its hardware products to the specifications applicable at the time of sale in accordance with TI's standard warranty. Testing and other quality control techniques are used to the extent TI deems necessary to support this warranty. Except where mandated by government requirements, testing of all parameters of each product is not necessarily performed.

TI assumes no liability for applications assistance or customer product design. Customers are responsible for their products and applications using TI components. To minimize the risks associated with customer products and applications, customers should provide adequate design and operating safeguards.

TI does not warrant or represent that any license, either express or implied, is granted under any TI patent right, copyright, mask work right, or other TI intellectual property right relating to any combination, machine, or process in which TI products or services are used. Information published by TI regarding third-party products or services does not constitute a license from TI to use such products or services or a warranty or endorsement thereof. Use of such information may require a license from a third party under the patents or other intellectual property of the third party, or a license from TI under the patents or other intellectual property of TI.

Reproduction of TI information in TI data books or data sheets is permissible only if reproduction is without alteration and is accompanied by all associated warranties, conditions, limitations, and notices. Reproduction of this information with alteration is an unfair and deceptive business practice. TI is not responsible or liable for such altered documentation. Information of third parties may be subject to additional restrictions.

Resale of TI products or services with statements different from or beyond the parameters stated by TI for that product or service voids all express and any implied warranties for the associated TI product or service and is an unfair and deceptive business practice. TI is not responsible or liable for any such statements.

TI products are not authorized for use in safety-critical applications (such as life support) where a failure of the TI product would reasonably be expected to cause severe personal injury or death, unless officers of the parties have executed an agreement specifically governing such use. Buyers represent that they have all necessary expertise in the safety and regulatory ramifications of their applications, and acknowledge and agree that they are solely responsible for all legal, regulatory and safety-related requirements concerning their products and any use of TI products in such safety-critical applications, notwithstanding any applications-related information or support that may be provided by TI. Further, Buyers must fully indemnify TI and its representatives against any damages arising out of the use of TI products in such safety-critical applications.

TI products are neither designed nor intended for use in military/aerospace applications or environments unless the TI products are specifically designated by TI as military-grade or "enhanced plastic." Only products designated by TI as military-grade meet military specifications. Buyers acknowledge and agree that any such use of TI products which TI has not designated as military-grade is solely at the Buyer's risk, and that they are solely responsible for compliance with all legal and regulatory requirements in connection with such use.

TI products are neither designed nor intended for use in automotive applications or environments unless the specific TI products are designated by TI as compliant with ISO/TS 16949 requirements. Buyers acknowledge and agree that, if they use any non-designated products in automotive applications, TI will not be responsible for any failure to meet such requirements.

Following are URLs where you can obtain information on other Texas Instruments products and application solutions:

Products

Amplifiers	amplifier.ti.com
Data Converters	dataconverter.ti.com
DSP	dsp.ti.com
Clocks and Timers	www.ti.com/clocks
Interface	interface.ti.com
Logic	logic.ti.com
Power Mgmt	power.ti.com
Microcontrollers	microcontroller.ti.com
RFID	www.ti-rfid.com
RF/IF and ZigBee® Solutions	www.ti.com/lprf

Applications

Audio	www.ti.com/audio
Automotive	www.ti.com/automotive
Broadband	www.ti.com/broadband
Digital Control	www.ti.com/digitalcontrol
Medical	www.ti.com/medical
Military	www.ti.com/military
Optical Networking	www.ti.com/opticalnetwork
Security	www.ti.com/security
Telephony	www.ti.com/telephony
Video & Imaging	www.ti.com/video
Wireless	www.ti.com/wireless

Mailing Address: Texas Instruments, Post Office Box 655303, Dallas, Texas 75265
Copyright © 2008, Texas Instruments Incorporated