

622Mbps Clock & Data Recovery with High Sensitivity Limiting Amplifier

Description

The CXB1565R achieves 3R optical-fiber communication receiver functions (Reshaping and Regenerating and Retiming) on a single chip. This IC also equipped with the signal interruption alarm output, which is used to discriminate the existence of data input.

Features

- Auto-offset canceler circuit
- Signal interruption alarm output
- No reference clock required
- Single 5V power supply

Applications

- SONET/SDH: 622.08Mbps
- ATM: 622.08Mbps

Absolute Maximum Ratings

• Supply voltage	$V_{CC} - V_{EE}$	-0.3 to +7.0	V
• Storage temperature	T_{stg}	-65 to +150	°C
• Input voltage difference: $ V_D - V_{DN} $	V_{dif}	0 to 2.5	V
• TTL input voltage	V_{inT}	-0.5 to 5.5	V
• Output current (Continuous)	I_o	0 to 50	mA
(Surge)		0 to 100	mA

Recommended Operating Conditions

• Supply voltage	$V_{CC} - V_{EE}$	4.5 to 5.5	V
• Termination voltage (for RCK/RDATA)	$V_{CC} - V_{T1}$	1.8 to 2.2	V
• Termination voltage (for SDE)	V_{T2}	V_{EE}	V
• Termination resistance (for RCK/RDATA)	R_{T1}	46 to 56	Ω
• Termination resistance (for SDE)	R_{T2}	460 to 560	Ω
• Operating temperature	T_a	-40 to +85	°C

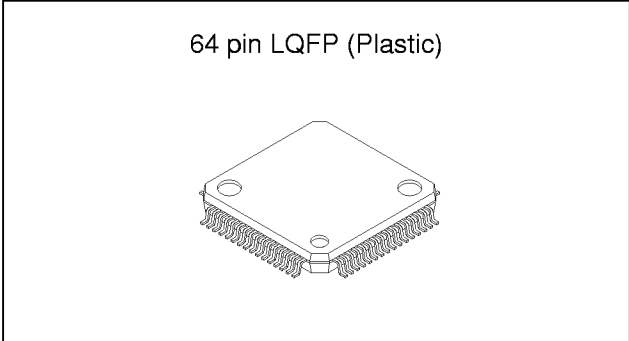

Sony reserves the right to change products and specifications without prior notice. This information does not convey any license by any implication or otherwise under any patents or other right. Application circuits shown, if any, are typical examples illustrating the operation of the devices. Sony cannot assume responsibility for any problems arising out of the use of these circuits.

Block Diagram and Pin Configuration

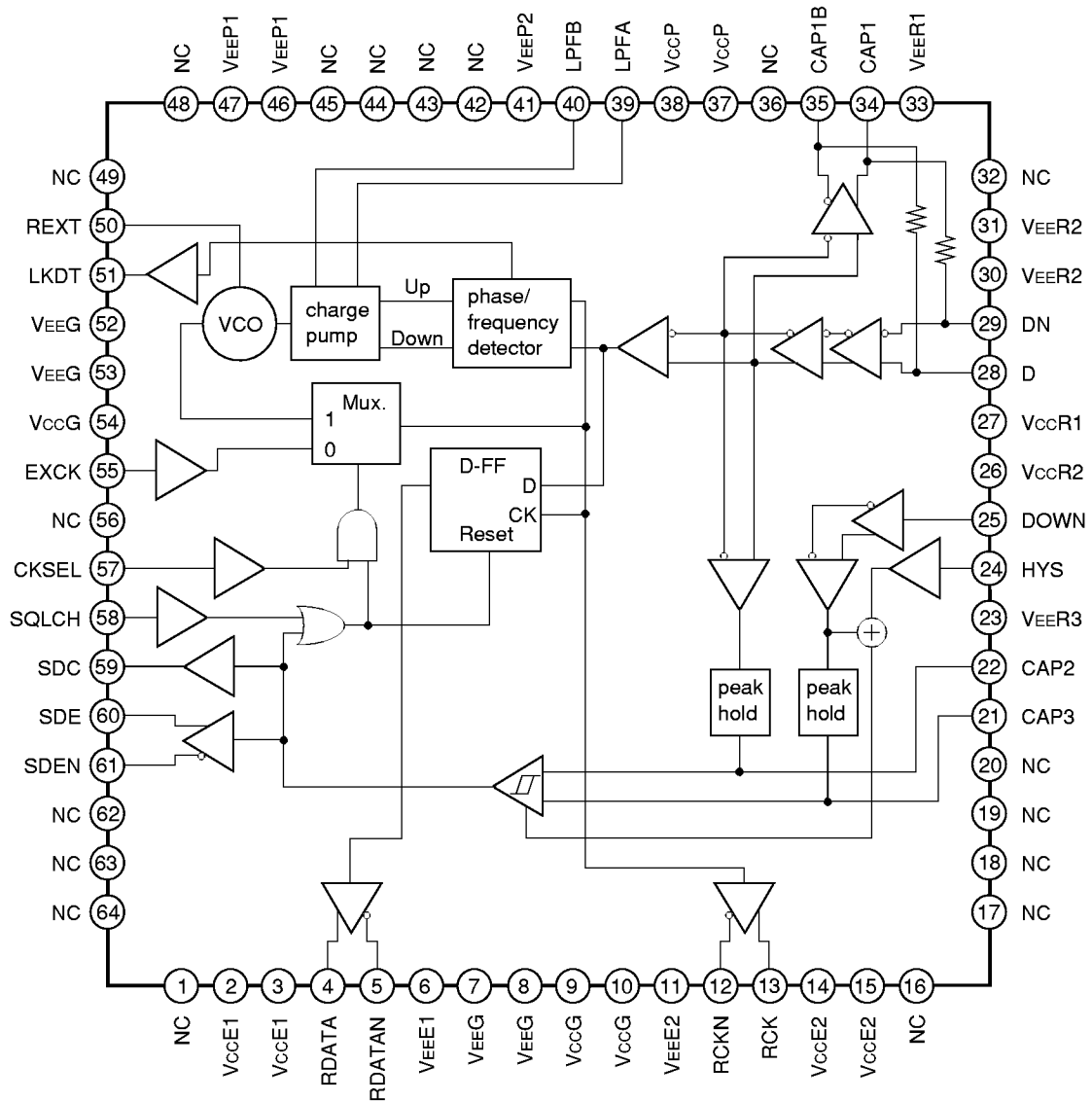

Pin Description

Pin No.	Symbol	Typical pin voltage (V)		Equivalent circuit	Description
		DC	AC		
1, 16 to 20	NC				No connect
2, 3	V _{CC} E1	5			Positive supply for RDATA/RDATAN output circuits.
4	RDATA		3.3 to 4.1		Retimed data outputs.
5	RDATAN		3.3 to 4.1		
6	V _{EE} E1	0			Ground for RDATA/RDATAN output circuits.
7, 8 52, 53	V _{EE} G	0			Ground for digital circuits.
9, 10 54	V _{CC} G	5			Positive supply for digital circuits.
11	V _{EE} E2	0			Ground for RCK/RCKN outputs circuits.
12	RCKN		3.3 to 4.1		Recovered clock outputs.
13	RCK		3.3 to 4.1		
14, 15	V _{CC} E2	5			Positive supply for RCK/RCKN output circuits.
21	CAP3	3.2			Connect a peak hold capacitor for signal detector. Typically 470pF.
22	CAP2	3.2			

Pin No.	Symbol	Typical pin voltage (V)		Equivalent circuit	Description	
		DC	AC			
23	V _{EE} R3	0			Ground for signal detector.	
24	HYS	0.3			<p>Connect to V_{EE}R3 through an external resistor to determine signal detect hysteresis width (ΔP).</p> <p>When connect to V_{EE}R3 directly. $\Delta P \approx 6\text{dB (Typ.)}$</p> <p>When 8.2k$\Omega$ is inserted. $\Delta P \approx 3\text{dB (Typ.)}$</p>	
25	DOWN	4.4			<p>Connect to V_{CC}R2 through an external resistor to decrease signal detect level (SDL). When open, SDL sets to 20mVp-p. (single-ended)</p>	
26	V _{CC} R2	5			Positive supply for signal detector.	
27	V _{CC} R1	0			Positive supply for post amplifier.	
28	D				Serial data stream inputs.	
29	DN					
34	CAP1	3.7				Connect a external capacitor, which determines low cut-off frequency for feedback block. Typically 0.022 μF .
35	CAP1B	3.7				
30, 31	V _{EE} R2	0			Ground for post amplifier.	
32, 36	NC				No connect	
33	V _{EE} R1	0			Ground for post amplifier. Both V _{EE} R1 and V _{EE} R2 must be grounded.	
37, 38	V _{CC} P	5			Positive supply for PLL circuits.	

Pin No.	Symbol	Typical pin voltage (V)		Equivalent circuit	Description
		DC	AC		
39	LPFA				<p>Connect a external loop filter capacitor. Typically 0.33μF.</p>
40	LPFB				
41	VEEP2	0			Ground for PLL circuits.
42 to 45 48, 49 56	NC				No connect
46, 47	VEEP1	0			Ground for PLL circuits. Both VEE P1 and VEE P2 must be grounded.
50	REXT	0.6			<p>Connect to VEE P1 through a external resistor to determine VCO frequency. Typically 2.4kΩ.</p>
51	LKDT		0.2 to 4.8		<p>Lock detector (TTL). Driven low, while synchronization is lost. If SQLCH is asserted(low),fixed high even when lock is lost.</p>

Pin No.	Symbol	Typical pin voltage (V)		Equivalent circuit	Description
		DC	AC		
55	EXCK	3			External clock input (ECL). For testing only. Normally, left open.
57	CKSEL	5			Clock selector (TTL). When low, EXCK is active instead of VCO output. Normally, left open.
58	SQLCH	5			TTL input. When Low, RCK and RDATA fix Low, in case of data loss. When high, RCK outputs VCO free-run frequency, in case of data loss.
59	SDC		0.2 to 4.8		Signal detect output (TTL). Driven low, while input serial data is lost.
60	SDE				Signal detect outputs (ECL). SDE is driven low, while input serial data is lost.
61	SDEN				
62 to 64	NC				No connect

Electrical Characteristics

• DC characteristics

(V_{CC} = +5V ± 10%, V_{EE} = GND, T_a = -40°C to +85°C)

Item	Symbol	Conditions	Min.	Typ.	Max.	Unit
Supply current	I _{CC}	All outputs open		95	130	mA
TTL input High voltage	V _{IHT}		2		5.5	V
TTL input Low voltage	V _{ILT}		0		0.8	V
RDATA/RCK output High voltage	V _{OH1} *1	51Ω to V _{CC} - 2V	V _{CC} - 1.1		V _{CC} - 0.83	V
RDATA/RCK output Low voltage	V _{OL1} *1	51Ω to V _{CC} - 2V	V _{CC} - 1.86		V _{CC} - 1.55	V
SDE output High voltage	V _{OH2} *1	510Ω to V _{EE}	V _{CC} - 1.1		V _{CC} - 0.83	V
SDE output Low voltage	V _{OL2} *1	510Ω to V _{EE}	V _{CC} - 1.86		V _{CC} - 1.55	V
TTL output High voltage	V _{OHT}	I _{OH} = -0.4mA	2.6			V
TTL output Low voltage	V _{OLT}	I _{OL} = 2.1mA			0.5	V
Maximum input voltage amplitude	V _{max}		1600			mV
D/DB input resistance	R _{in}		1125	1500	1875	Ω

*1 T_a = 0°C to +85°C

• AC characteristics

(V_{CC} = +5V ± 10%, V_{EE} = GND, T_a = -40°C to +85°C)

Item	Symbol	Conditions	Min.	Typ.	Max.	Unit
Post amplifier gain	GL	Except for output buffer	40			dB
Signal detect hysteresis width	ΔP	HYS = V _{EE} R3, R _d ≥ 2kΩ	3		7.5	dB
Signal detect response assert time	T _{as}	CAP2, CAP3 = 470ps DOWN = OPEN	0		100	μs
Signal detect response deassert time	T _{das}	D = 200mVp-p, Single ended	2.3		100	μs
RCK/RCKN output jitter	R _J	*1		3.6		degrees rms
PLL band width	f _c *2	*1			500	kHz
Jitter peaking		*1			0.1	dB
Jitter Tolerance		f = 10Hz, *1 *3 30Hz, *1 *3 300Hz, *1 *3 25kHz, *1 *3 250kHz, *1 *3	15 15 1.5 1.5 0.15			UI
PLL capture range			622.01	622.08	622.15	Mbps
PLL pull in time	T _p	*1		10		ms
RCK/RCKN output rise/fall time	T _{RC} /T _{FC}	51Ω to V _{CC} - 2V, 20% to 80%		250	350	ps
RDATA/RDATAN output rise/fall time	T _{RD} /T _{FC}	51Ω to V _{CC} - 2V, 20% to 80%		350	500	ps

*1 D = 50mVp-p (single-ended), 2²³ - 1 PRBS, under the AC Electrical characteristics measurement circuit.*2 f_c: frequency which attenuates the input sinusoidal jitter by 3dB.

*3 Bit error rate threshold: 1E - 10

DC Electrical Characteristics Measurement Circuit

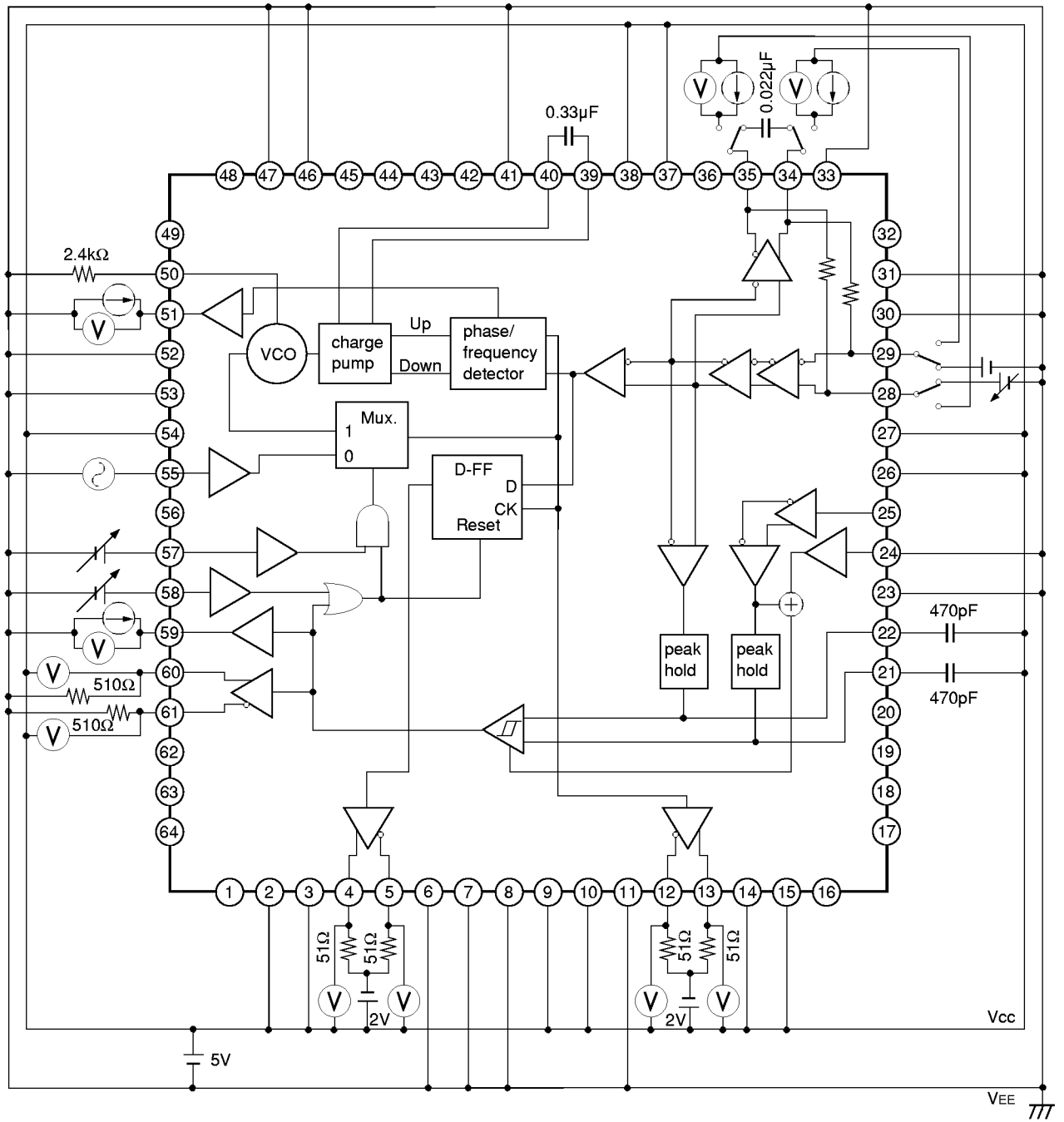

AC Electrical Characteristics Measurement Circuit

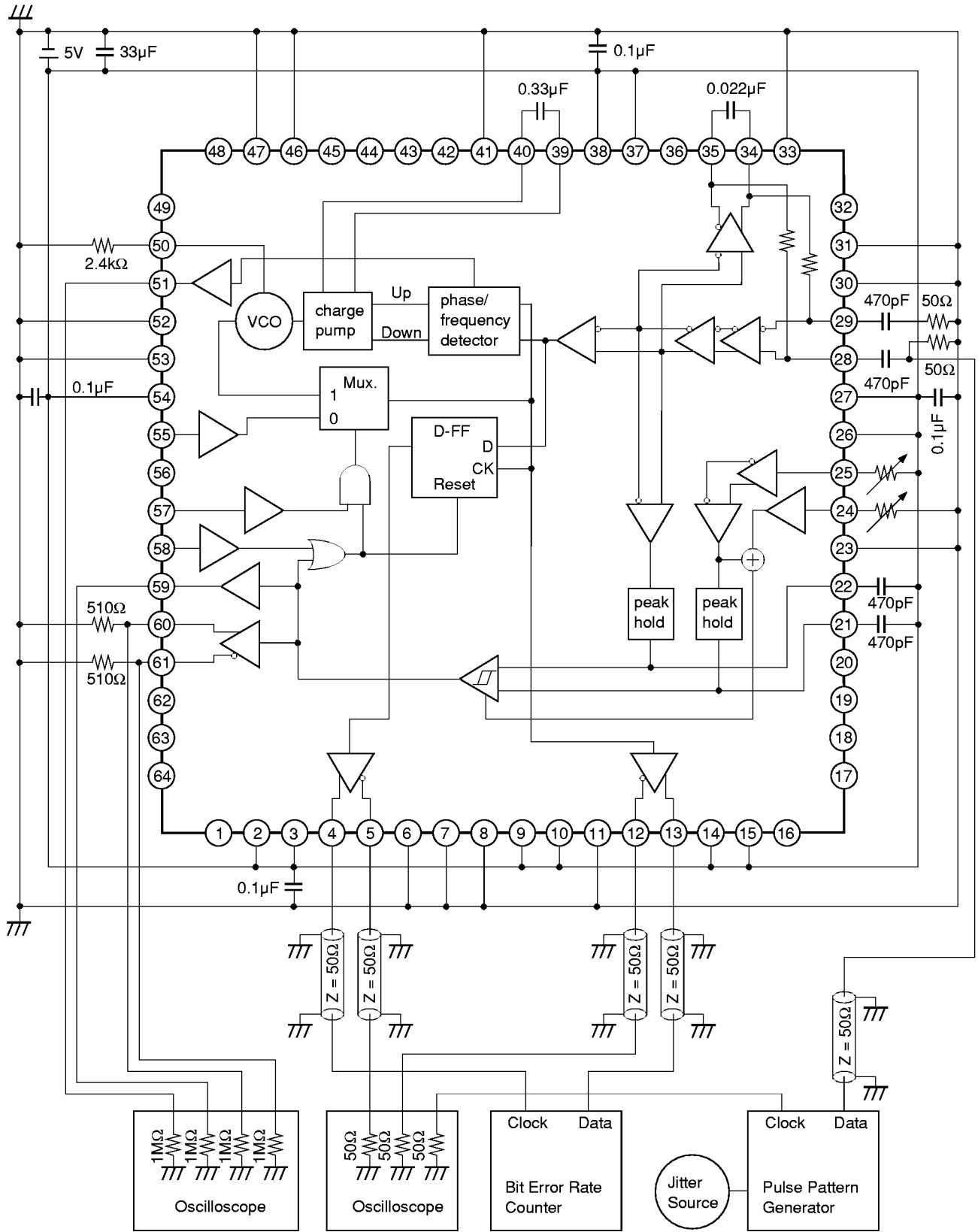

Application Circuit

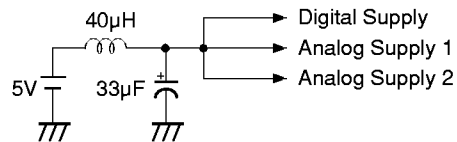
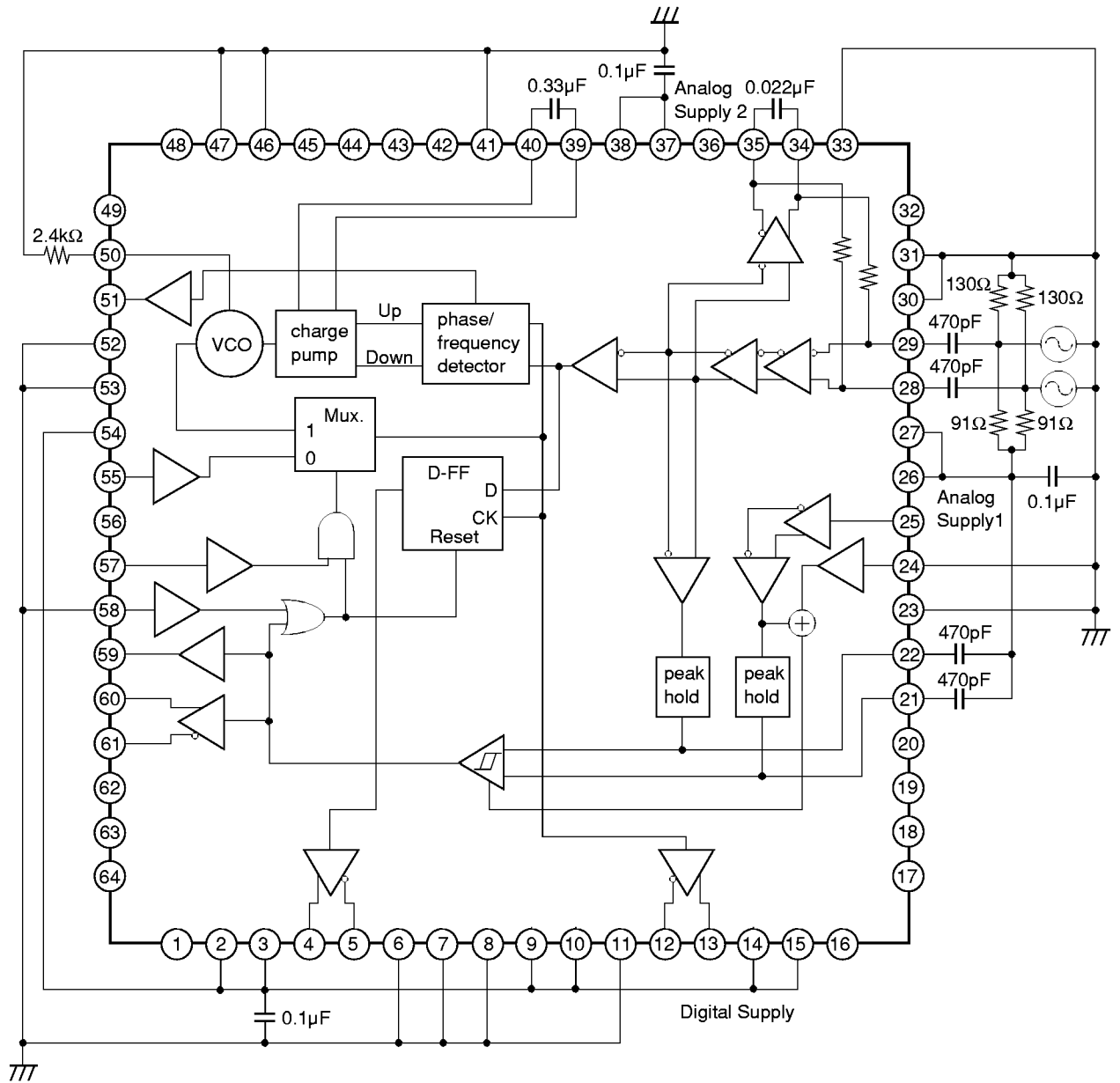

Application circuits shown are typical examples illustrating the operation of the devices. Sony cannot assume responsibility for any problems arising out of the use of these circuits or for any infringement of third party patent and other right due to same.

Notes on Operation

1. Limiting amplifier block

The limiting amplifier block is equipped with the auto-offset canceler circuit. When external capacitors C1 and C2 are connected as shown in Fig. 1, the DC bias is set automatically in this block. External capacitor C1 and IC internal resistor R1 determine the low input cut-off frequency f_2 as shown in Fig. 2. Similarly, external capacitor C2 and IC internal resistor R2 determine the high cut-off frequency f_1 for DC bias feedback. Since peaking characteristics may occur in the low frequency area of the amplifier gain characteristics depending on the f_1/f_2 combination, set the C1 and C2 so as to avoid the occurrence of peaking characteristics. The target values of R1 and R2 and the typical values of C1 and C2 are as indicated below. When a single-ended input is used, provide AC grounding by connecting Pin 29 to a capacitor which has the same capacitance as capacitor C1.

R1 (internal): 1.5k Ω	} f2: 225kHz	R2 (internal): 10k Ω	} f1: 723Hz
C1 (external): 470pF		C2 (external): 0.022 μ F	

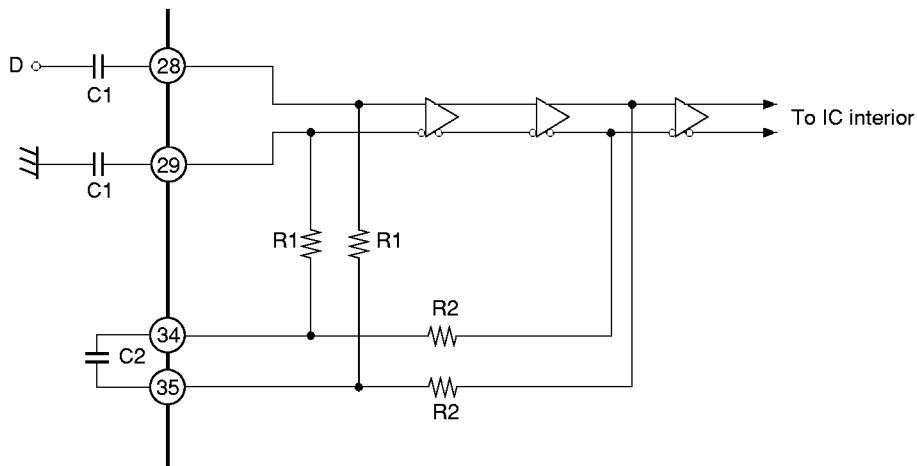

Fig. 1

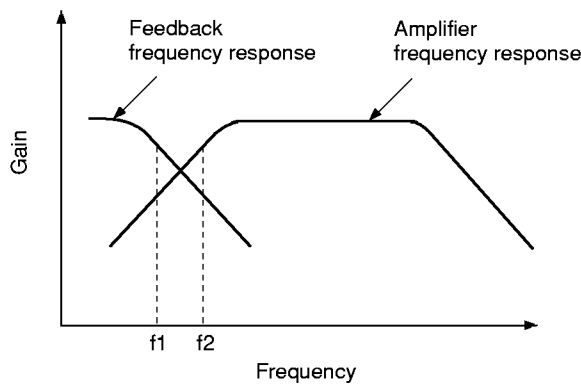

Fig. 2

2. Alarm block

This block provides a signal interruption alarm output used for open fibre control (OFC).

Signal detect threshold level and hysteresis width are both user adjustable.

Signal detect threshold default level is 20mVp-p (single-ended).

An external resistor R_d between DOWN and V_{ccR} decrease it.

Typical characteristics of R_d vs. threshold level is shown in fig. 7, 8.

Hysteresis width can be also decreased by an external resistor R_H . Typical characteristics of R_H vs. ΔP is shown in fig. 9.

Timing chart of signal detect function is shown in fig. 5. SD response assert/deassert time are decided by peak hold capacitor C_R and C_S . Their typical value is 470pF each.

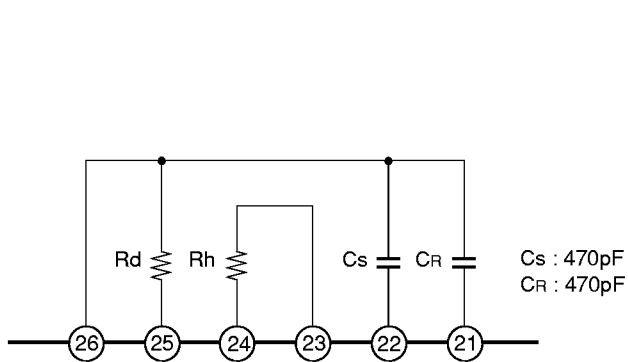

Fig. 3

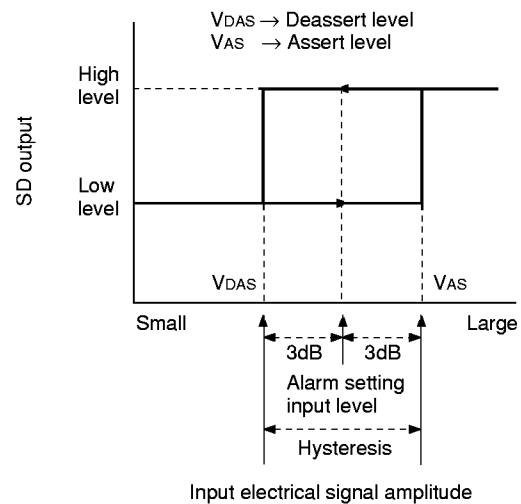

Fig. 4

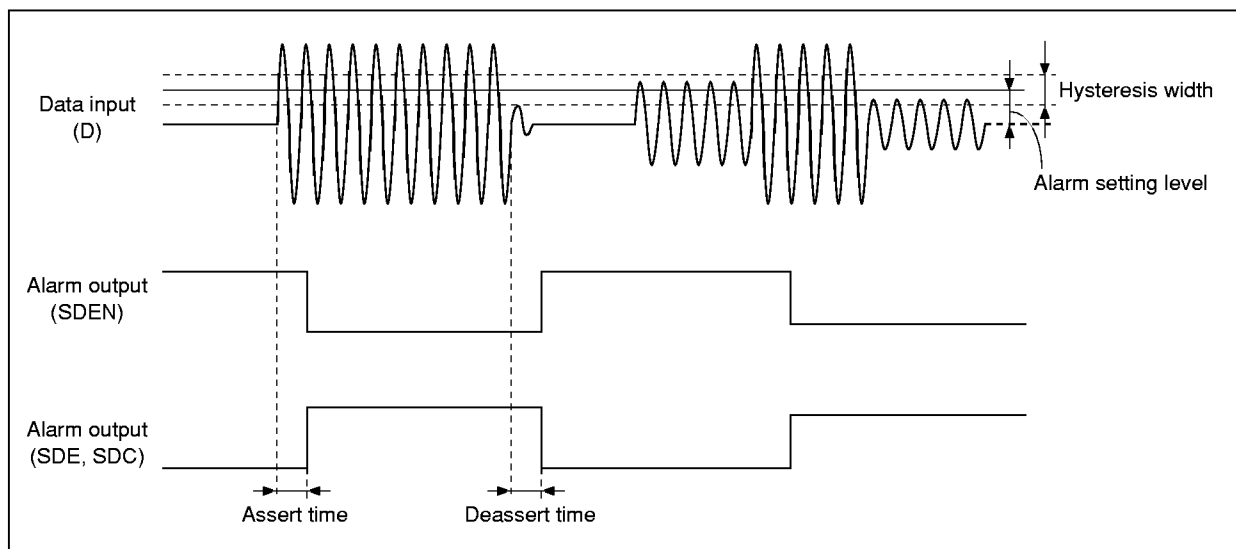

Fig. 5. Timing Chart

3. Clock and Data recovery block

Clock recovery is realized by fully integrated phase locked loop (PLL), which needs no external reference clock. PLL accepts scrambled NRZ data with 50% mark density. Two external components Re and Cp are required. Their recommended values are shown in fig. 6.

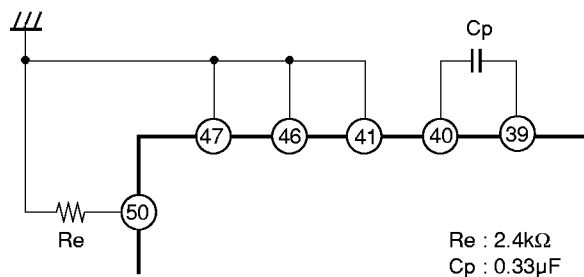

Fig. 6

Re is a resistor which decides VCO center frequency. To reduce the temperature dependence of the VCO oscillation frequency, Re should have a small temperature coefficient. In addition, Re should place as near as IC terminal to obtain good jitter performance.

Cp is a loop filter capacitance. Since loop damping factor ξ is function of \sqrt{Cp} , Cp is also important to have a small temperature coefficient. Damping factor ξ is given as

$$20,000 \times \sqrt{Cp} \quad (@\rho = 1/2) \text{ *3}$$

Recommended Cp value gives a ξ of 10, and jitter peaking of under 0.1dB is specified.

*3 ρ : data transition density

4. Others

Pay attention to handling this IC because its electrostatic discharge strength is weak.

Example of Representative Characteristics

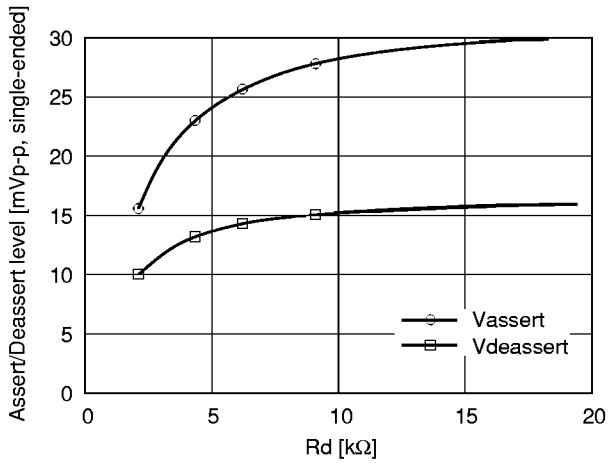

Vcc = 5V, Ta = 27°C
 622.08Mbps, 2²³ – 1PRBS
 Rh = 0Ω

Fig. 7. Rd vs. Assert/Deassert level

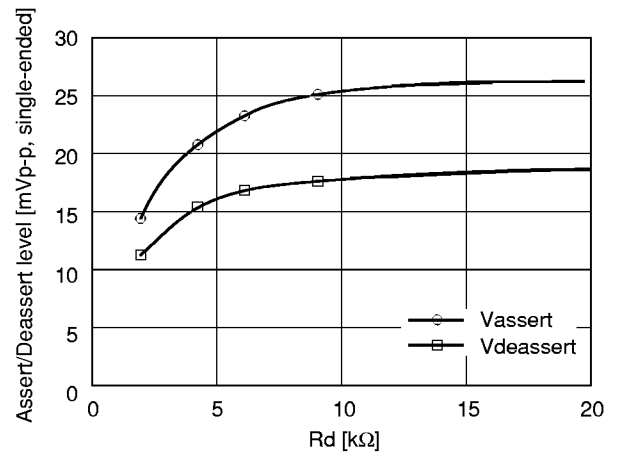

Vcc = 5V, Ta = 27°C
 622.08Mbps, 2²³ – 1PRBS
 Rh = 8.2kΩ

Fig. 8. Rd vs. Assert/Deassert level
 (RH = 8.2kΩ)

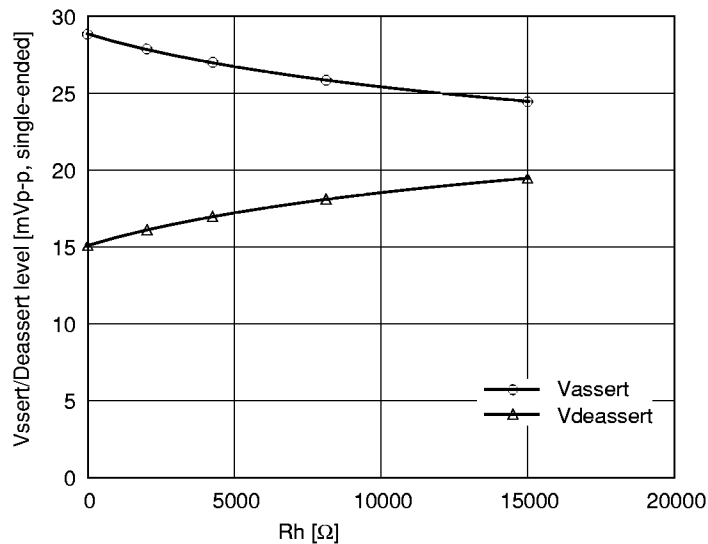

Vcc = 5V, Ta = 27°C
 622.08Mbps, 2²³ – 1PRBS
 Rd = ∞

Fig. 9. Rh vs. Assert/Deassert level

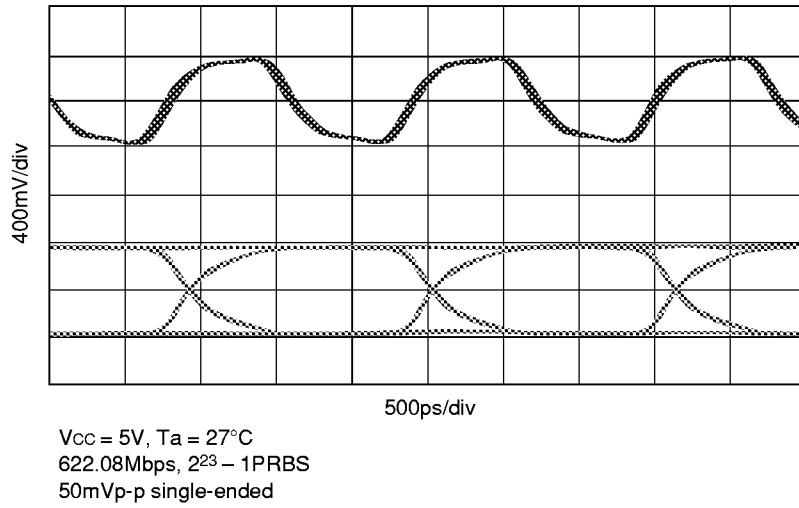

Fig. 10. RCK/RDATA output waveform

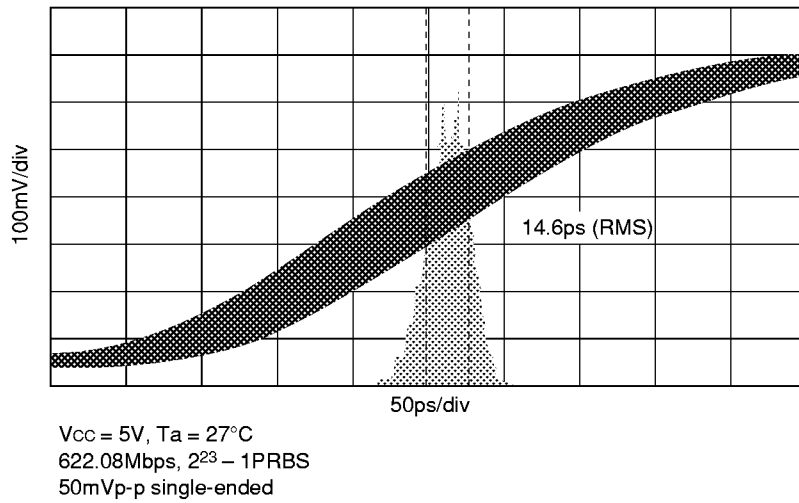

Fig. 11. RCK output histogram

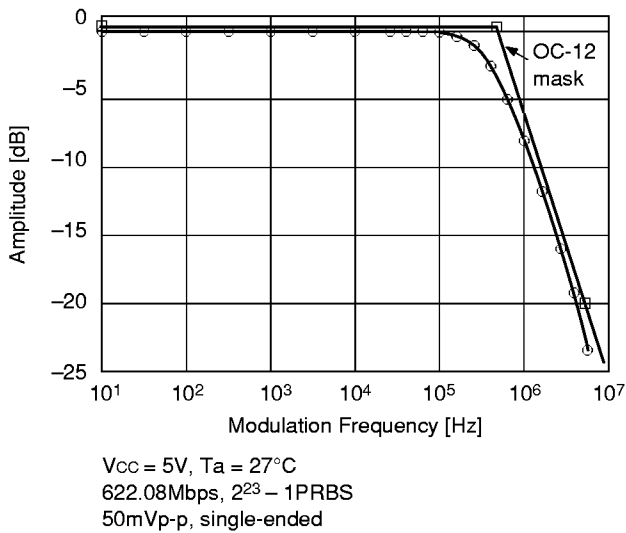

Fig. 12. Jitter transfer function

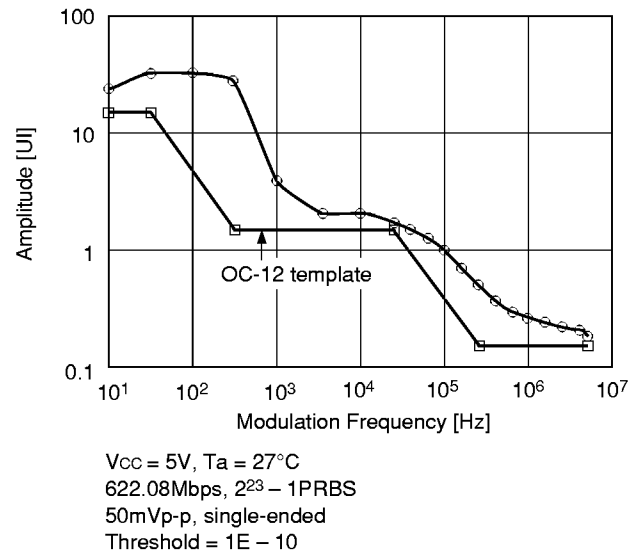
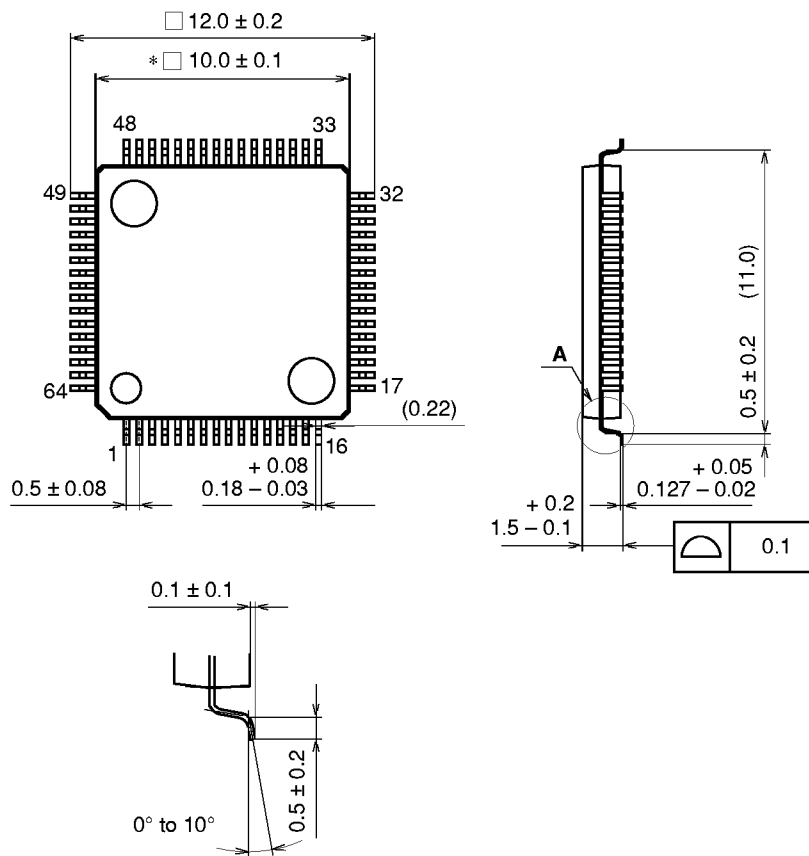

Fig. 13. Jitter tolerance

Package Outline Unit: mm

64PIN LQFP (PLASTIC)



NOTE: Dimension "*" does not include mold protrusion.

DETAIL A

PACKAGE STRUCTURE

SONY CODE	LQFP-64P-L01
EIAJ CODE	LQFP064-P-1010
JEDEC CODE	_____

PACKAGE MATERIAL	EPOXY RESIN
LEAD TREATMENT	SOLDER/PALLADIUM PLATING
LEAD MATERIAL	42/COPPER ALLOY
PACKAGE MASS	0.3g