

**SANYO Semiconductors****DATA SHEET**

LA7832 — Monolithic Linear IC

Color TV Vertical Deflection Output Circuit

Overview

The LA7832 is a monolithic linear IC for vertical deflection output for small and mid-sized color television sets that requires few external components and dissipates little power. When used in conjunction with the LA7620 series of video chroma deflection ICs, the LA7800 series of deflection ICs, and the LA7850 series of display ICs, it is possible to create a stable and compact vertical output deflection circuit.

Features

- High output.
- Low power dissipation due to built-in pump-up circuit.
- Few external components needed.
- Thermal protection circuit built in.

Specifications**Maximum Ratings** at $T_a = 25^\circ\text{C}$

Parameter	Symbol	Conditions	Ratings	Unit
Maximum supply voltage	V_G max	(Pump-up block)	30	V
	V_3 max	(Output block)	62	V
Deflection output current	I_2 max		± 1.5	Ap-o
Allowable power dissipation	P_d max	With arbitrarily large heat sink	8	W
Operating temperature	T_{opr}		-20 to +85	$^\circ\text{C}$
Storage temperature	T_{stg}		-40 to +150	$^\circ\text{C}$
Thermal resistance	θ_{j-c}		4	$^\circ\text{C/W}$

■ Any and all SANYO Semiconductor Co.,Ltd. products described or contained herein are, with regard to "standard application", intended for the use as general electronics equipment (home appliances, AV equipment, communication device, office equipment, industrial equipment etc.). The products mentioned herein shall not be intended for use for any "special application" (medical equipment whose purpose is to sustain life, aerospace instrument, nuclear control device, burning appliances, transportation machine, traffic signal system, safety equipment etc.) that shall require extremely high level of reliability and can directly threaten human lives in case of failure or malfunction of the product or may cause harm to human bodies, nor shall they grant any guarantee thereof. If you should intend to use our products for applications outside the standard applications of our customer who is considering such use and/or outside the scope of our intended standard applications, please consult with us prior to the intended use. If there is no consultation or inquiry before the intended use, our customer shall be solely responsible for the use.

■ Specifications of any and all SANYO Semiconductor Co.,Ltd. products described or contained herein stipulate the performance, characteristics, and functions of the described products in the independent state, and are not guarantees of the performance, characteristics, and functions of the described products as mounted in the customer's products or equipment. To verify symptoms and states that cannot be evaluated in an independent device, the customer should always evaluate and test devices mounted in the customer's products or equipment.

SANYO Semiconductor Co., Ltd.

TOKYO OFFICE Tokyo Bldg., 1-10, 1 Chome, Ueno, Taito-ku, TOKYO, 110-8534 JAPAN

Operating Conditions at $T_a = 25^\circ\text{C}$

Parameter	Symbol	Conditions	Ratings	Unit
Recommended supply voltage	V_6		24	V
Operating supply voltage range	V_6		10 to 27	V
Deflection output current	I_{2P-P}		to 1.8	Ap-p

Electrical Characteristics at $T_a = 25^\circ\text{C}$, $V_6 = 24\text{V}$

Parameter	Symbol	Conditions	min	typ	max	Unit
Deflection output saturation voltage (lower)	$V(\text{sat})_{2-1}$	$I_2 = +0.9\text{ A}$			1.2	V
Deflection output saturation voltage (upper)	$V(\text{sat})_{3-2}$	$I_2 = -0.9\text{ A}$			3.2	V
Pump-up charge saturation voltage	$V(\text{sat})_{7-1}$	$I_7 = +20\text{ mA}$			1.8	V
Pump-up discharge saturation voltage	$V(\text{sat})_{6-7}$	$I_7 = -0.9\text{ A}$			3.0	V
Idling current	I_{DL}		30		60	mA
Midpoint voltage	V_{MID}		9.5	10.5	11.5	V

Package Dimensions

unit : mm (typ)

3075A

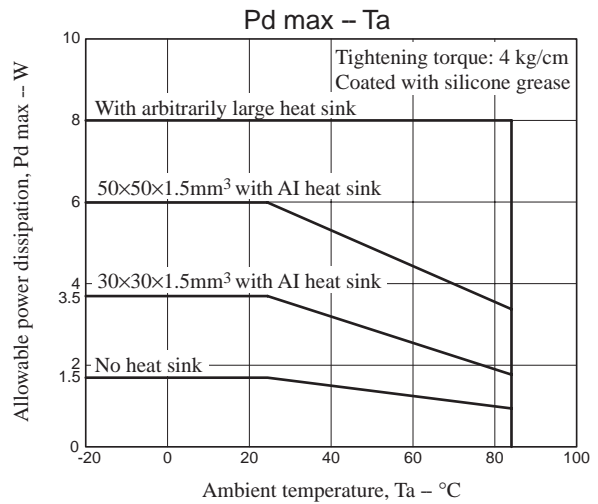
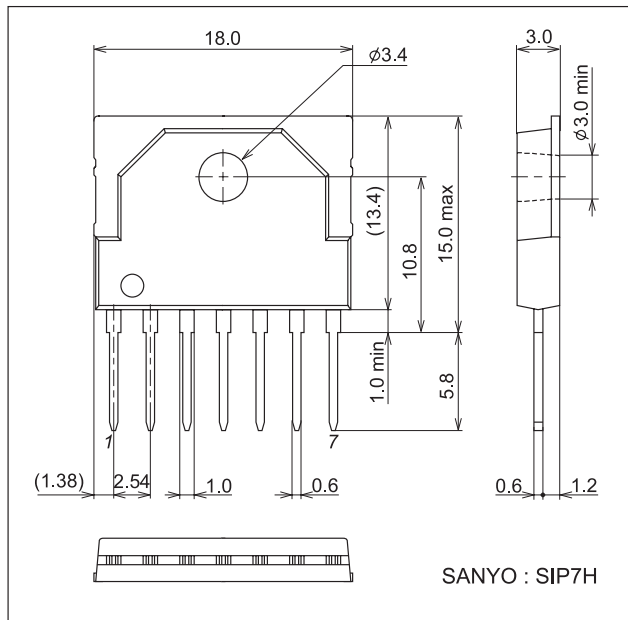

Pin Assignment and Block Diagram

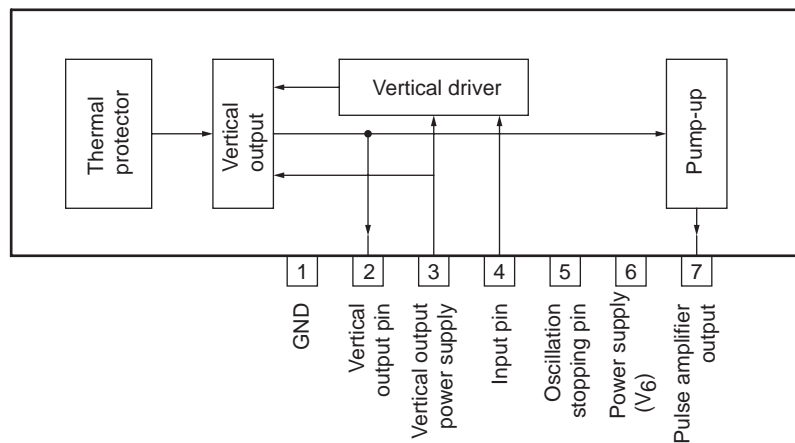

Sample Application Circuit

LA7820 vertical output

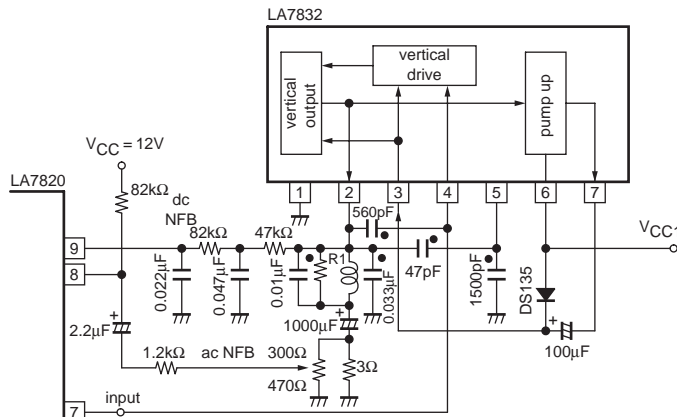

R1* = several hundreds of ohms to 1kΩ
 *: CR used against oscillation
 The combination depends on the oscillation mode.

Sample Application Circuit

LA7620 vertical output

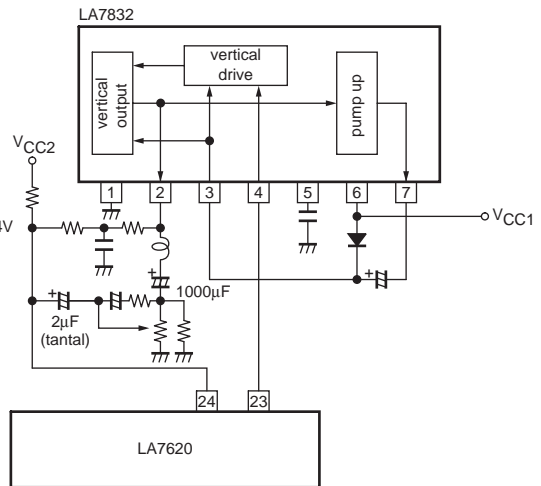

Sample Application Circuit

LA7850 vertical output

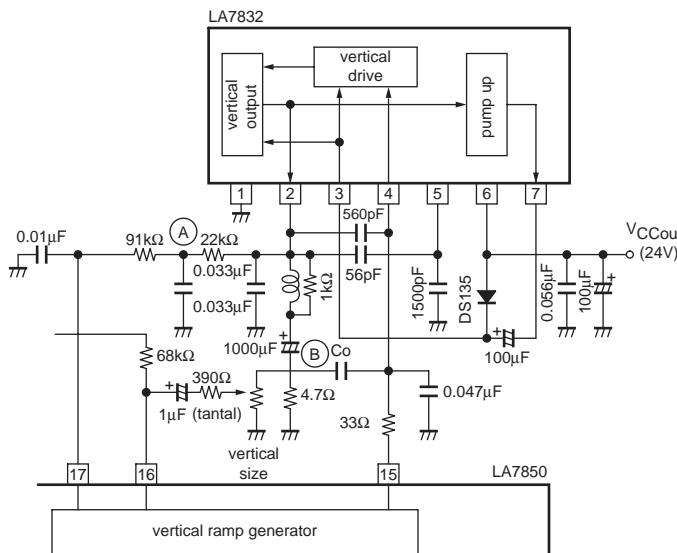

- SANYO Semiconductor Co.,Ltd. assumes no responsibility for equipment failures that result from using products at values that exceed, even momentarily, rated values (such as maximum ratings, operating condition ranges, or other parameters) listed in products specifications of any and all SANYO Semiconductor Co.,Ltd. products described or contained herein.
- SANYO Semiconductor Co.,Ltd. strives to supply high-quality high-reliability products, however, any and all semiconductor products fail or malfunction with some probability. It is possible that these probabilistic failures or malfunction could give rise to accidents or events that could endanger human lives, trouble that could give rise to smoke or fire, or accidents that could cause damage to other property. When designing equipment, adopt safety measures so that these kinds of accidents or events cannot occur. Such measures include but are not limited to protective circuits and error prevention circuits for safe design, redundant design, and structural design.
- In the event that any or all SANYO Semiconductor Co.,Ltd. products described or contained herein are controlled under any of applicable local export control laws and regulations, such products may require the export license from the authorities concerned in accordance with the above law.
- No part of this publication may be reproduced or transmitted in any form or by any means, electronic or mechanical, including photocopying and recording, or any information storage or retrieval system, or otherwise, without the prior written consent of SANYO Semiconductor Co.,Ltd.
- Any and all information described or contained herein are subject to change without notice due to product/technology improvement, etc. When designing equipment, refer to the "Delivery Specification" for the SANYO Semiconductor Co.,Ltd. product that you intend to use.
- Information (including circuit diagrams and circuit parameters) herein is for example only; it is not guaranteed for volume production.
- Upon using the technical information or products described herein, neither warranty nor license shall be granted with regard to intellectual property rights or any other rights of SANYO Semiconductor Co.,Ltd. or any third party. SANYO Semiconductor Co.,Ltd. shall not be liable for any claim or suits with regard to a third party's intellectual property rights which has resulted from the use of the technical information and products mentioned above.

This catalog provides information as of June, 2008. Specifications and information herein are subject to change without notice.