

Features

- PowerPC 60x/7xx bus.
 - 66.66 MHz (IBM25CPC700BB3B66).
 - 83.33 MHz (IBM25CPC700BB3B83).
 - Synchronous DRAM interface operates at the processor bus speed with support for ECC.
 - PCI Revision 2.1 Compliant Interface.
 - ROM/SRAM/External peripheral controller.
 - Interrupt Controller supports interrupts from a variety of sources.
 - Programmable Timers.
 - Two 2-wire, 8-bit, 16550 compatible UARTs.
 - Two independent IIC interfaces.
 - Byte swapping supported for bi-endian operation.
 - Internal PCI Bus Arbiter for PCI bus speeds up to 33.33 MHz (may be disabled for use with an external arbiter).
 - 32-bit PCI bus operates at frequencies from 25MHz to 66.66 Mhz.
 - Uses standard type 0 PCI configuration register
- map essential to making it appear like a device but does not preclude it from being a host.
- Supports independent primary and secondary resource management mapping. This feature enables the CPC700 to effectively isolate local processing resources from host side memory and I/O allocations. Through the use of three independent translation decodes, the PowerPC operating environment access to PCI is managed solely by the PowerPC.
 - Dual address capabilities enhance the CPC700's capabilities by allowing it to manage, control, or test beyond 4 Giga-byte limitations.
 - Support for shared memory is locally mapped to the processor's ROM or SDRAM through PCI standard Base Address Registers. Two Memory/I/O BARs are available for requesting host memory or I/O resources and managing PCI to PowerPC access.
 - Provides a special interface enabling the CPC700 to generate any PCI command, including Type 1 configuration cycles.
 - Fully buffers PCI writes and supports PCI read pre-fetching from local memory.
 - Hardware enforces cache coherency.
 - Implemented in CMOS5SE.
-

Contents

Section 1. "Description" 3

Section 2. "Electrical Characteristics" 4

Section 3. "Signal Description" 11

Section 4. "Package Information" 17

Section 5. "Ordering Information" 18

1. Description

The CPC700 contains a bridge from the PowerPC processor to the PCI bus, as well as a high-speed memory controller, internal peripherals, and control for external ROM and external peripherals. The CPC700 is a general purpose solution for interfacing the high performance, superscalar, PowerPC 603e, 740, and 750 families of RISC microprocessors to a PCI bus and system memory.

CPC700 Embedded Bridge Functional Block Diagram

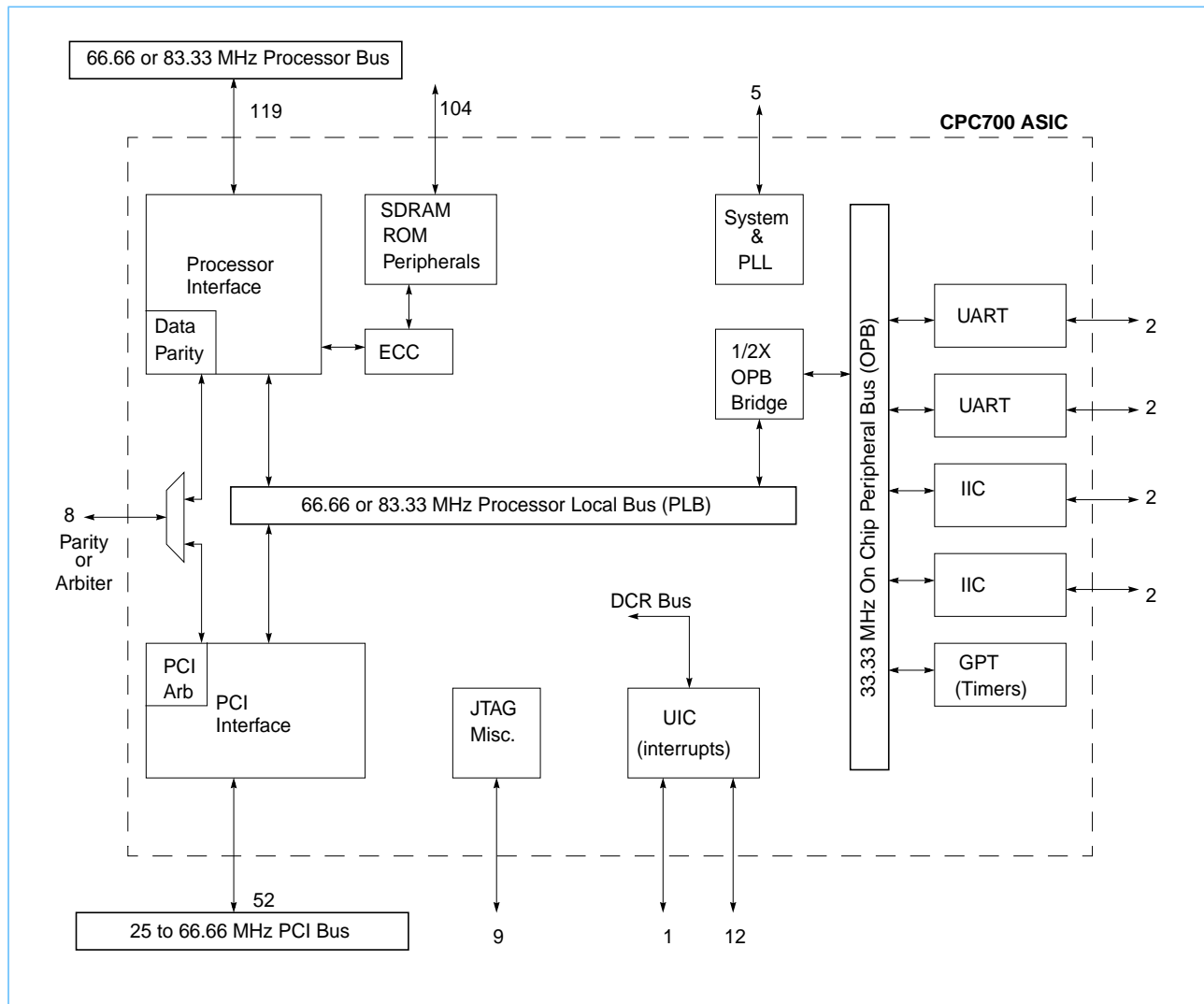

2. Electrical Characteristics

Absolute Maximum Ratings

Characteristic	Symbol	Value	Unit
Supply Voltage	V_{DD}	0 to 3.6	V
PLL0 Supply Voltage	AV_{DD0}	0 to 3.6	V
PLL1 Supply Voltage	AV_{DD1}	0 to 3.6	V
Input Voltage	V_{IN}	0 to 3.6	V
Storage Temperature Range	T_{STG}	-65 to 150	°C

Recommended DC Operating Conditions⁵

Parameter	Symbol	Min	Typ	Max	Unit	Notes
Supply Voltage	V_{DD}	3.135	3.3	3.465	V	
PLL0 Supply Voltage	V_{DD}	3.135	3.3	3.465	V	
PLL1 Supply Voltage	V_{DD}	3.135	3.3	3.465	V	
Input Logic High (3.3V receivers)	V_{IH}	2.0		V_{DD}	V	
Input Logic High (5.0V receivers)	V_{IH}	2.0		5.50	V	
Input Logic Low	V_{IL}	0.0		0.8	V	
Output Logic High	V_{OH}	2.4		V_{DD}	V	
Output Logic Low	V_{OL}	0.0		0.4	V	
Input Leakage Current Group 1	I_{IL1}	—	<1	10	μA	2
Input Leakage Current Group 2	I_{IL2}	—	—	400	μA	3
Input Leakage Current Group 3	I_{IL3}	—	—	-250	μA	4
Input Max Allowable Overshoot (3.3V receivers)	V_{IMAO3}			$V_{DD} + 0.6$	V	
Input Max Allowable Overshoot (5.0V receivers)	V_{IMAO5}			5.50	V	
Input Max Allowable Undershoot (3.3V receivers)	V_{IMAU3}			-0.60	V	
Input Max Allowable Undershoot (5.0V receivers)	V_{IMAU5}			-0.60	V	
Output Max Allowable Overshoot (3.3V receivers)	V_{OMAO3}			$V_{DD} + 0.6$	V	
Output Max Allowable Overshoot (5.0V receivers)	V_{OMAO5}			5.50	V	
Output Max Allowable Undershoot (3.3V receivers)	V_{OMAU3}			-0.60	V	
Die Junction Temperature	T_J	-40		105	°C	

1. Refer to the Output Signal Power Ranges Table for power information.
2. Input leakage currents for all inputs except those indicated in Notes 3 and 4.
3. Input leakage current for signals TEST_ENABLE, GBL_N, TSIZ[0], TSIZ[1], TT[0], AND TT[4].
4. Input leakage current for signals TSIZ[2], TT[1], TRST_N, TDI, TMS, TCK, DI1, AND DI2.
5. In addition to any other specification herein, all CPC700 PCI bus IOs meet or exceed the PCI v2.1 requirements for 3.3V and 5.0V signalling environments.

Capacitance

	Symbol	Min	Max	Unit	Notes
Input Capacitance Group 1	CIN1	—	5	pF	1, 3
Input Capacitance Group 1	CIN2	—	8	pF	2, 3

1. Group 1 includes all signals except those indicated in note 2.
 2. Group 2 includes GBL_N, TSIZ[0], TSIZ[1], TT[4], and TT[0].
 3. Excludes test signals TEST_ENABLE, DI1_N, DI2_N, RI_N, and JTAG signals.

DC Electrical Characteristics

Parameter	Symbol	Min	Typ	Max	Unit	Notes
Thermal Resistance, Junction to Ambient				15	°C/W	1
Thermal Resistance, Junction to Balls				5.9	°C/W	1,2
Active Operating Current	I _{DD}			420 (66.66 MHz) 500 (83.33 MHz)	mA	3
PLL0 Voltage	V _{PLL0}	3.135	3.3	3.465	V	
PLL0 VDD Input current	I _{PLL0}			14	mA	
PLL1 Voltage	V _{PLL1}	3.135	3.3	3.465	V	
PLL1 VDD Input current	I _{PLL1}			14	mA	

1. Under normal operating conditions, the CPC700 does not require a heat sink.
 2. Measured from junction to outside corner ball.
 3. I_{DD} Max is measured at T_c = 105 °C, worst case operating conditions for frequency and voltage, and a capacitive load of 50 pF.

Power

Power	Processor/Memory Frequency		Units	Notes
	66.66	83.33	MHz	
Typical	1.1	1.2	W	1, 2
Maximum	1.6	1.9	W	2, 3, 4

1. Typical power is measured at VDD=3.3V, 27 °C in a system executing typical sequences.
2. Guaranteed by design and characterization and is not tested.
3. Maximum power is measured at VDD=3.6V, 120 °C in a system executing worse case sequences with the CPU caches disabled
4. Maximum power at -40 °C can be derived by subtracting .05 W from the maximum power number at 120 °C.

I/O Specifications (Part 1 of 4)

Signal	I/O	Input (ns)		Output (ns)		Output Current (mA)		Clock	Notes
		Setup Time (min)	Hold Time (min)	Valid Delay (max)	Hold Time (min)	I/O H (max)	I/O L (min)		
CPU Bus Interface^{1, 2}									
A[0:31]	I/O	3.0	1.0	10.3	3.7			Sys (2X)	
AACK_N	O			9.3	3.6	10.2	6.8	Sys (2X)	
AP[0:3]	I/O	2.5	1.0	9.4	3.4	16.8	14	Sys (2X)	
ARTRY_N	I/O	2.5	1.0	8.5	3.2	10.2	6.8	Sys (2X)	
BG_N	O			8.5	3.2	10.2	6.8	Sys (2X)	
BR_N	I	3.0	1.0					Sys (2X)	
DBG_N	O			9.5	3.5	10.2	6.8	Sys (2X)	
DH[0:31]	I/O	3.0	1.0	9.6	3.4	10.2	6.8	Sys (2X)	
DL[0:31]	I/O	3.0	1.0	9.8	3.5	10.2	6.8	Sys (2X)	
DP[0:7]	I/O	2.5	1.0	6.1	1.8	16.8	14	Sys (2X)	7
GBL_N	O			9.5	3.5	10.2	6.8	Sys (2X)	
MCP_N	O			10.3	3.9	10.2	6.8	Sys (2X)	
MCP_REQ	I	2.5	1.0					Sys (2X)	7
TA_N	O			9.1	3.4	10.2	6.8	Sys (2X)	
TBST_N	I/O	2.5	1.0	10.1	3.6	10.2	6.8	Sys (2X)	
TS_N	I/O	3.0	1.0	8.6	3.2	10.2	6.8	Sys (2X)	
TSIZ[0:2]	I/O	2.5	1.0	9.8	3.7	10.2	6.8	Sys (2X)	
TT[0:4]	I/O	2.5	1.0	9.3	3.5	10.2	6.8	Sys (2X)	
Memory Controller Interface^{1, 2}									
BA0	O			11.1	2.8	19	16	Sys (2X)	
BA1	O			10.6	2.8	19	16	Sys (2X)	
BANK_SEL_N[0:4]	O			8.1	2.8	13.4	9	Sys (2X)	
CAS_N	O			6.6	2.4	19	16	Sys (2X)	
CKE	O			6.8	2.4	19	16	Sys (2X)	
M_DATA[0:63]	I/O	3.0	1.0	7.8	2.8	13.4	9	Sys (2X)	
DQM[0]	O			6.9	2.5	19	16	Sys (2X)	
ECC[0]	I/O	3.0	1.0	8.0	2.9	13.4	9	Sys (2X)	
ECC[1:7]/DQM[1:7]	I/O	3.0	1.0	8.0	2.9	13.4	9	Sys (2X)	
MA[0:12]	O			11.1	3.0	19	16	Sys (2X)	
RAS_N	O			6.9	2.4	19	16	Sys (2X)	
WE_N	O			6.7	2.4	19	16	Sys (2X)	

PCI Bus Asynchronous Operation^{1, 2, 3, 5, 7}

1. Timing is guaranteed by design and characterization and is not tested.
2. All IO timing (CPU, PCI, and other) is specified into a 50 pf load. All timings include errors (if any) induced by internal PLLs, given a clock input with no jitter.
 Sys (2X): Timings shown are referenced to the rising edge of the output of PLL0, operating at twice the frequency of the SYS_CLK input. PLL0 locks to the rising edge of SYS_CLK.
 Sys (1X): Timing is referenced to SYS_CLK.
 PCI (A): PCI interface in asynchronous mode. Timings are referenced to the PCI_CLK input. Logic is clocked by the output of PLL1, which repeats PCI_CLK.
 PCI (S): PCI interface in synchronous mode. Timings are referenced to the SYS_CLK, which is assumed to be exactly equal to the PCI clock...
3. Asynchronous PCI timings reflect 66.66 MHz PCI operation. Output timings are specified into a 50pF load.
4. PCI in 2:1 (CPU @ 66.66 MHz, PCI @ 33.33MHz).
5. All PCI timings meet or exceed PCI v2.1 specifications. System designers should design using the PCI timing budgets of the PCI version 2.1 specifications. Output delays are specified into a 50pF lumped load model.
6. IIC output timing specified into a 250pF load.
7. This is a 5.0V receiver. Other receivers are 3.3V receivers.

I/O Specifications (Part 2 of 4)

Signal	I/O	Input (ns)		Output (ns)		Output Current (mA)		Clock	Notes
		Setup Time (min)	Hold Time (min)	Valid Delay (max)	Hold Time (min)	I/O H (max)	I/O L (min)		
AD[0:31]	I/O	1.6	0.0	5.6	1.6	16.8	14	PCI (A)	
C/BE_N[0:3]	I/O	2.6	0.0	5.7	1.7	16.8	14	PCI (A)	
DEVSEL_N	I/O	2.9	0.0	5.8	1.6	16.8	14	PCI (A)	
FRAME_N	I/O	2.9	0.0	5.6	1.8	16.8	14	PCI (A)	
IDSEL	I	1.8	0.0					PCI (A)	
IRDY_N	I/O	2.8	0.0	5.3	1.7	16.8	14	PCI (A)	
PAR	I/O	2.3	0.0	5.3	1.8	16.8	14	PCI (A)	
PERR_N	I/O	1.8	0.0	5.4	1.7	16.8	14	PCI (A)	
RST_N	O			n/a	n/a	13.4	9		
STOP_N	I/O	2.7	0.0	5.8	1.7	16.8	14	PCI (A)	
TRDY_N	I/O	2.6	0.0	5.8	1.7	16.8	14	PCI (A)	
SERR_N	O			5.8	1.7	16.8	14	PCI (A)	

PCI Bus 2:1 Synchronous Operation^{1, 2, 4, 5, 7}

AD[0:31]	I/O	3.8	0.0	8.7	2.9	16.8	14	PCI (S)	
C/BE_N[0:3]	I/O	5.5	0.0	8.6	2.8	16.8	14	PCI (S)	
DEVSEL_N	I/O	4.8	0.0	8.4	2.8	16.8	14	PCI (S)	
FRAME_N	I/O	5.2	0.0	8.3	2.8	16.8	14	PCI (S)	
IDSEL	I	2.5	0.0			16.8	14	PCI (S)	
IRDY_N	I/O	5.2	0.0	7.9	2.8	16.8	14	PCI (S)	
PAR	I/O	4.7	0.0	8.5	2.8			PCI (S)	
PERR_N	I/O	4.1	0.0	8.8	3.1	16.8	14	PCI (S)	
STOP_N	I/O	3.6	0.0	8.5	2.9	16.8	14	PCI (S)	
TRDY_N	I/O	4.6	0.0	8.5	2.9	16.8	14	PCI (S)	
SERR_N	O			8.3	2.3	16.8	14	PCI (S)	

PCI Arbitration^{1, 2, 5}

- Timing is guaranteed by design and characterization and is not tested.
- All IO timing (CPU, PCI, and other) is specified into a 50 pf load. All timings include errors (if any) induced by internal PLLs, given a clock input with no jitter.
 Sys (2X): Timings shown are referenced to the rising edge of the output of PLL0, operating at twice the frequency of the SYS_CLK input. PLL0 locks to the rising edge of SYS_CLK.
 Sys (1X): Timing is referenced to SYS_CLK.
 PCI (A): PCI interface in asynchronous mode. Timings are referenced to the PCI_CLK input. Logic is clocked by the output of PLL1, which repeats PCI_CLK.
 PCI (S): PCI interface in synchronous mode. Timings are referenced to the SYS_CLK, which is assumed to be exactly equal to the PCI clock...
- Asynchronous PCI timings reflect 66.66 MHz PCI operation. Output timings are specified into a 50pF load.
- PCI in 2:1 (CPU @ 66.66 MHz, PCI @ 33.33MHz).
- All PCI timings meet or exceed PCI v2.1 specifications. System designers should design using the PCI timing budgets of the PCI version 2.1 specifications. Output delays are specified into a 50pF lumped load model.
- IIC output timing specified into a 250pF load.
- This is a 5.0V receiver. Other receivers are 3.3V receivers.

I/O Specifications (Part 3 of 4)

Signal	I/O	Input (ns)		Output (ns)		Output Current (mA)		Clock	Notes
		Setup Time (min)	Hold Time (min)	Valid Delay (max)	Hold Time (min)	I/O H (max)	I/O L (min)		
GNT0_N/REQ_N	O			8.8	2.7	16.8	14	PCI (A)	Async Internal Arbiter
				9.3	2.9	16.8	14	PCI (S)	Sync Internal Arbiter
				5.3	1.7	16.8	14	PCI (A)	Async External Arbiter
				7.6	2.6	16.8	14	PCI (S)	Sync External Arbiter
REQ0_N/GNT_N	I	4.7	0.0					PCI (A)	Async Internal Arbiter
		4.7	0.0					Sys (S)	Sync Internal Arbiter
		2.7	0.0					PCI (A)	Async External Arbiter
		5.1	0.0					PCI (S)	Sync External Arbiter
REQ[1:5]_N	I	4.4	0.0					PCI (A)	Async Internal Arbiter
		4.4	0.0					PCI (S)	Sync Internal Arbiter
GNT[1:5]_N	O			8.8	2.7	16.8	14	PCI (A)	Async Internal Arbiter
				9.3	2.9	16.8	14	PCI (S)	Sync Internal Arbiter

ROM Interface

ROM_ALE	O			12.1	4.5	10.2	6.8	Sys (2X)	
ROM_OE_N	O			8.1	2.8	19	16	Sys (2X)	

- Timing is guaranteed by design and characterization and is not tested.
- All IO timing (CPU, PCI, and other) is specified into a 50 pf load. All timings include errors (if any) induced by internal PLLs, given a clock input with no jitter.
 Sys (2X): Timings shown are referenced to the rising edge of the output of PLL0, operating at twice the frequency of the SYS_CLK input. PLL0 locks to the rising edge of SYS_CLK.
 Sys (1X): Timing is referenced to SYS_CLK.
 PCI (A): PCI interface in asynchronous mode. Timings are referenced to the PCI_CLK input. Logic is clocked by the output of PLL1, which repeats PCI_CLK.
 PCI (S): PCI interface in synchronous mode. Timings are referenced to the SYS_CLK, which is assumed to be exactly equal to the PCI clock...
- Asynchronous PCI timings reflect 66.66 MHz PCI operation. Output timings are specified into a 50pF load.
- PCI in 2:1 (CPU @ 66.66 MHz, PCI @ 33.33MHz).
- All PCI timings meet or exceed PCI v2.1 specifications. System designers should design using the PCI timing budgets of the PCI version 2.1 specifications. Output delays are specified into a 50pF lumped load model.
- IIC output timing specified into a 250pF load.
- This is a 5.0V receiver. Other receivers are 3.3V receivers.

I/O Specifications (Part 4 of 4)

Signal	I/O	Input (ns)		Output (ns)		Output Current (mA)		Clock	Notes
		Setup Time (min)	Hold Time (min)	Valid Delay (max)	Hold Time (min)	I/O H (max)	I/O L (min)		
ROM_RD_N	O			9.0	3.3	13.4	9	Sys (2X)	
ROM_READY	I	3.5	1.0					Sys (2X)	7
ROM_RNW	O			8.6	3.1	13.4	9	Sys (2X)	
ROM_WE_N	O			7.8	2.8	19	16	Sys (2X)	
ROM_WR_N	O			9.0	3.3	13.4	9	Sys (2X)	
IIC Port									
IIC_SCL	I/O	3.0	1.0	22.7	4.3	13.4	9	Sys (1X)	6, 7
IIC_SDA	I/O	2.0	1.0	21.6	4.3	13.4	9	Sys (1X)	6, 7
UART Ports									
UART_RX	I	2.5	1.0					Sys (1X)	
UART_TX	O			11.1	3.9	10.2	6.8	Sys (1X)	
Miscellaneous									
RESET_OUT_N	O					19	16	Sys (2X)	
IRQ_OUT_N	O					10.2	6.8		
TDO	O					10.2	6.8		

1. Timing is guaranteed by design and characterization and is not tested.
2. All IO timing (CPU, PCI, and other) is specified into a 50 pf load. All timings include errors (if any) induced by internal PLLs, given a clock input with no jitter.
 Sys (2X): Timings shown are referenced to the rising edge of the output of PLL0, operating at twice the frequency of the SYS_CLK input. PLL0 locks to the rising edge of SYS_CLK.
 Sys (1X): Timing is referenced to SYS_CLK.
 PCI (A): PCI interface in asynchronous mode. Timings are referenced to the PCI_CLK input. Logic is clocked by the output of PLL1, which repeats PCI_CLK.
 PCI (S): PCI interface in synchronous mode. Timings are referenced to the SYS_CLK, which is assumed to be exactly equal to the PCI clock...
3. Asynchronous PCI timings reflect 66.66 MHz PCI operation. Output timings are specified into a 50pF load.
4. PCI in 2:1 (CPU @ 66.66 MHz, PCI @ 33.33MHz).
5. All PCI timings meet or exceed PCI v2.1 specifications. System designers should design using the PCI timing budgets of the PCI version 2.1 specifications. Output delays are specified into a 50pF lumped load model.
6. IIC output timing specified into a 250pF load.
7. This is a 5.0V receiver. Other receivers are 3.3V receivers.

IRQ [0:11], RESET_N, and PCI_66_STRAP are asynchronous inputs that use 5.0V receivers. Timing to the clock and output characteristics are not specified for these pins

There are internal 13K Ohm pull-down resistors connected to pins TEST_ENABLE, GBL_N, TSIZ [0:1], TT [0], and TT [4]. There are internal 20K Ohm pull-up resistors connected to pins TSIZ [2] and TT [1].

Clock DC Specifications

	Minimum Vih	Maximum Vil	Cin
SYS_CLK	2.0V	0.8V	5pf
PCI_CLK	2.0V	0.8V	5pf

CPC700 - 66 Clock AC Specifications^{1, 2}

	Input		Jitter		Duty Cycle		Notes
	Fmin	Fmax	Short	Long	Min	Max	
SYS_CLK	10 MHz	33.33 MHz	100 ps	250 ps	40%	60%	
PCI_CLK	25 MHz	66.66 MHz	100 ps	250 ps	40%	60%	

1. In the clock tables, 25 MHz represents 1/(40ns), 33.33 MHz represents 1/(30ns), 41.66 MHz represents 1/(24ns), 66.66 MHz represents 1/(15ns), and 83.33 represents 1/(12ns).
2. For information on CPC700 operation with a spread spectrum clock, please contact your IBM technical representative.

CPC700 - 83 Clock AC Specifications^{1, 2}

	Input		Jitter		Duty Cycle		Notes
	Fmin	Fmax	Short	Long	Min	Max	
SYS_CLK	10 MHz	41.66 MHz	100 ps	250 ps	40%	60%	
PCI_CLK	25 MHz	66.66 MHz	100 ps	250 ps	40%	60%	

1. In the clock tables, 25 MHz represents 1/(40ns), 33.33 MHz represents 1/(30ns), 41.66 MHz represents 1/(24ns), 66.66 MHz represents 1/(15ns), and 83.33 represents 1/(12ns).
2. For information on CPC700 operation with a spread spectrum clock, please contact your IBM technical representative.

3. Signal Description

Pin Number List

(Part 1 of 9)

Pin	Signal
A01	NO BALL
A02	ECC7/DQM7
A03	ECC5/DQM5
A04	M_DATA63
A05	M_DATA61
A06	UNUSED
A07	M_DATA59
A08	UNUSED
A09	M_DATA41
A10	UNUSED
A11	M_DATA26
A12	UNUSED
A13	M_DATA22
A14	UNUSED
A15	M_DATA08
A16	M_DATA01
A17	BANK_SEL_N2
A18	BANK_SEL_N1
A19	GND
AA01	AD03
AA02	GND
AA03	VDD
AA04	A02
AA05	A16
AA06	VDD
AA07	DL06
AA08	GND
AA09	DL22
AA10	VDD
AA11	DH08
AA12	GND
AA13	DH13
AA14	VDD
AA15	DP7/GNT5_N
AA16	DH25
AA17	AP3
AA18	GND
AA19	A31
AB01	AD00
AB02	AD01
AB03	A06
AB04	A10
AB05	A24
AB06	DL01
AB07	DL08
AB08	DL18
AB09	DL11
AB10	DH05
AB11	DH06
AB12	DH19
AB13	DH12
AB14	DH17
AB15	DH21

Pin Number List

(Part 2 of 9)

Pin	Signal
AB16	DH29
AB17	A27
AB18	DL25
AB19	AP0
AC01	A00
AC02	A08
AC03	A04
AC04	VDD
AC05	DL04
AC06	DL07
AC07	DH02
AC08	VDD
AC09	DL17
AC10	DP1/REQ3_N
AC11	DH07
AC12	VDD
AC13	RI
AC14	DH18
AC15	DH24
AC16	VDD
AC17	DL29
AC18	DL23
AC19	DL28
AD01	A14
AD02	A12
AD03	A20
AD04	A28
AD05	DP3/REQ5_N
AD06	GND
AD07	DH03
AD08	DL10
AD09	DH00
AD10	GND
AD11	DH14
AD12	DP2/REQ4_N
AD13	DP5/GNT3_N
AD14	GND
AD15	DH26
AD16	DH28
AD17	DL31
AD18	DL24
AD19	DL27
AE01	GND
AE02	A22
AE03	A26
AE04	A30
AE05	DL02
AE06	UNUSED
AE07	DH09
AE08	UNUSED
AE09	DH10
AE10	UNUSED
AE11	DH11

Pin Number List

(Part 3 of 9)

Pin	Signal
AE12	UNUSED
AE13	DH27
AE14	UNUSED
AE15	DH30
AE16	DH31
AE17	DL30
AE18	DL26
AE19	GND
B01	UART0_TX
B02	ECC6/DQM6
B03	ECC4/DQM4
B04	M_DATA62
B05	M_DATA60
B06	GND
B07	M_DATA47
B08	M_DATA42
B09	M_DATA39
B10	GND
B11	M_DATA25
B12	M_DATA21
B13	M_DATA23
B14	GND
B15	M_DATA00
B16	M_DATA02
B17	BANK_SEL_N3
B18	BANK_SEL_N0
B19	CKE
C01	UART0_RX
C02	UART1_TX
C03	ECC1/DQM1
C04	VDD
C05	M_DATA54
C06	M_DATA55
C07	M_DATA45
C08	VDD
C09	M_DATA35
C10	VDD
C11	M_DATA27
C12	VDD
C13	M_DATA13
C14	M_DATA09
C15	M_DATA03
C16	VDD
C17	BANK_SEL_N4
C18	CAS_N
C19	RAS_N
D01	IRQ0
D02	UART1_RX
D03	ECC0
D04	ECC2/DQM2
D05	M_DATA58
D06	M_DATA46
D07	M_DATA44

Pin Number List

(Part 4 of 9)

Pin	Signal
D08	M_DATA40
D09	M_DATA36
D10	M_DATA31
D11	M_DATA17
D12	M_DATA19
D13	M_DATA12
D14	M_DATA11
D15	M_DATA04
D16	UNUSED
D17	MA11
D18	WE_N
D19	DQM0
E01	IRQ02
E02	GND
E03	IIC0_SCL
E04	ECC3/DQM3
E05	M_DATA57
E06	VDD
E07	M_DATA43
E08	GND
E09	M_DATA34
E10	VDD
E11	M_DATA18
E12	GND
E13	M_DATA15
E14	VDD
E15	M_DATA05
E16	M_DATA06
E17	MA06
E18	GND
E19	MA09
F01	UNUSED
F02	IIC1_SCL
F03	IIC1_SDA
F04	IIC0_SDA
F05	M_DATA56
F06	UNUSED
F07	GND
F08	M_DATA32
F09	M_DATA33
F10	M_DATA30
F11	M_DATA24
F12	M_DATA20
F13	M_DATA14
F14	M_DATA10
F15	M_DATA07
F16	MA03
F17	MA05
F18	MA07
F19	UNUSED
G01	IRQ05
G02	GND
G03	IRQ01
G04	VDD
G05	IRQ04

Pin Number List

(Part 5 of 9)

Pin	Signal
G06	GND
G07	UNUSED
G08	VDD
G09	UNUSED
G10	GND
G11	UNUSED
G12	VDD
G13	UNUSED
G14	GND
G15	ROM_RD_N
G16	VDD
G17	MA04
G18	MA10/AP
G19	MA08
H01	PCIPLL_VDDA
H02	IRQ06
H03	PCI_CLK
H04	VDD
H05	IRQ03
H06	UNUSED
H07	UNUSED
H08	UNUSED
H09	M_DATA53
H10	M_DATA38
H11	M_DATA16
H12	UNUSED
H13	UNUSED
H14	ROM_ALE
H15	UNUSED
H16	MA02
H17	MA01
H18	MA00
H19	MA12
J01	UNUSED
J02	VDD
J03	IRQ08
J04	GND
J05	IRQ10
J06	VDD
J07	UNUSED
J08	GND
J09	M_DATA52
J10	VDD
J11	M_DATA29
J12	GND
J13	UNUSED
J14	VDD
J15	UNUSED
J16	GND
J17	BA1
J18	VDD
J19	UNUSED
K01	RST_N
K02	IRQ11
K03	TMS

Pin Number List

(Part 6 of 9)

Pin	Signal
K04	REQ0_N/GNT_N
K05	GNT1_N
K06	IRQ09
K07	UNUSED
K08	M_DATA49
K09	M_DATA51
K10	M_DATA37
K11	M_DATA28
K12	ROM_OE_N
K13	UNUSED
K14	UNUSED
K15	ROM_WR_N
K16	ROM_RNW
K17	TDO
K18	BA0
K19	SYS_RESET_N
L01	UNUSED
L02	DEVSEL_N
L03	PAR
L04	VDD
L05	IRQ07
L06	GND
L07	IDSEL
L08	VDD
L09	M_DATA50
L10	GND
L11	GND
L12	VDD
L13	ROM_READY
L14	GND
L15	ROM_WE_N
L16	VDD
L17	RESET_OUT_N
L18	PCI_66_STRAP
L19	UNUSED
M01	AD28
M02	AD20
M03	REQ1_N
M04	AD30
M05	AD31
M06	SERR_N
M07	GNT0_N/REQ_N
M08	PERR_N
M09	VDD
M10	M_DATA48
M11	VDD
M12	DBG_N
M13	TA_N
M14	AACK_N
M15	TEST_ENABLE
M16	MCP_N
M17	SYS_CLK
M18	GND
M19	SYSPLL_VDDA
N01	AD19

Pin Number List

(Part 7 of 9)

Pin	Signal
N02	VDD
N03	AD27
N04	GND
N05	AD26
N06	VDD
N07	FRAME_N
N08	GND
N09	AD29
N10	GND
N11	TSIZ2
N12	GND
N13	TSIZ1
N14	VDD
N15	BR_N
N16	GND
N17	GBL_N
N18	VDD
N19	MCP_REQ
P01	C/BE_N0
P02	AD21
P03	TCK
P04	IRDY_N
P05	AD23
P06	TRDY_N
P07	AD24
P08	AD11
P09	VDD
P10	AD25
P11	VDD
P12	ARTRY_N
P13	IRQ_OUT_N
P14	TS_N
P15	TT3
P16	TSIZ0
P17	TDI
P18	VDD
P19	TRST_N
R01	AD15
R02	AD17
R03	AD18
R04	VDD
R05	AD14
R06	GND
R07	UNUSED
R08	VDD
R09	DL03
R10	GND
R11	DL12
R12	VDD
R13	A23
R14	GND
R15	TT0
R16	VDD
R17	BG_N
R18	TT4

Pin Number List

(Part 8 of 9)

Pin	Signal
R19	TBST_N
T01	AD13
T02	C/BE_N1
T03	AD16
T04	STOP_N
T05	AD12
T06	UNUSED
T07	UNUSED
T08	C/BE_N3
T09	DL14
T10	DL13
T11	DL09
T12	DL19
T13	UNUSED
T14	A01
T15	A21
T16	AP1
T17	A07
T18	TT1
T19	TT2
U01	UNUSED
U02	VDD
U03	AD22
U04	GND
U05	UNUSED
U06	VDD
U07	UNUSED
U08	GND
U09	UNUSED
U10	VDD
U11	DL05
U12	GND
U13	UNUSED
U14	VDD
U15	UNUSED
U16	GND
U17	A03
U18	VDD
U19	UNUSED
V01	DI1_N
V02	AD09
V03	DI2_N
V04	AD10
V05	C/BE_N2
V06	UNUSED
V07	UNUSED
V08	UNUSED
V09	DL16
V10	DH04
V11	DL00
V12	DH16
V13	UNUSED
V14	UNUSED
V15	A09
V16	AP2

Pin Number List

(Part 9 of 9)

Pin	Signal
V17	A11
V18	A13
V19	A05
W01	AD08
W02	AD07
W03	AD06
W04	VDD
W05	UNUSED
W06	GND
W07	UNUSED
W08	VDD
W09	DP0/REQ2_N
W10	GND
W11	DH15
W12	VDD
W13	UNUSED
W14	GND
W15	UNUSED
W16	VDD
W17	A15
W18	A25
W19	A17
Y01	UNUSED
Y02	AD04
Y03	AD05
Y04	AD02
Y05	A18
Y06	UNUSED
Y07	DP6/GNT4_N
Y08	DH01
Y09	DL15
Y10	DL20
Y11	DL21
Y12	DH20
Y13	DH23
Y14	UNUSED
Y15	DH22
Y16	DP4/GNT2_N
Y17	A19
Y18	A29
Y19	UNUSED

Signal Name List
(Part 1 of 9)

Pin	Signal
AC01	A00
T14	A01
AA04	A02
U17	A03
AC03	A04
V19	A05
AB03	A06
T17	A07
AC02	A08
V15	A09
AB04	A10
V17	A11
AD02	A12
V18	A13
AD01	A14
W17	A15
AA05	A16
W19	A17
Y05	A18
Y17	A19
AD03	A20
T15	A21
AE02	A22
R13	A23
AB05	A24
W18	A25
AE03	A26
AB17	A27
AD04	A28
Y18	A29
AE04	A30
AA19	A31
M14	AACK_N
AB01	AD00
AB02	AD01
Y04	AD02
AA01	AD03
Y02	AD04
Y03	AD05
W03	AD06
W02	AD07
W01	AD08
V02	AD09
V04	AD10
P08	AD11
T05	AD12
T01	AD13
R05	AD14
R01	AD15
T03	AD16
R02	AD17
R03	AD18
N01	AD19
M02	AD20
P02	AD21

Signal Name List
(Part 2 of 9)

Pin	Signal
U03	AD22
P05	AD23
P07	AD24
P10	AD25
N05	AD26
N03	AD27
M01	AD28
N09	AD29
M04	AD30
M05	AD31
AB19	AP0
T16	AP1
V16	AP2
AA17	AP3
P12	ARTRY_N
K18	BA0
J17	BA1
B18	BANK_SEL_N0
A18	BANK_SEL_N1
A17	BANK_SEL_N2
B17	BANK_SEL_N3
C17	BANK_SEL_N4
R17	BG_N
N15	BR_N
P01	C/BE_N0
T02	C/BE_N1
V05	C/BE_N2
T08	C/BE_N3
C18	CAS_N
B19	CKE
M12	DBG_N
L02	DEVSEL_N
AD09	DH00
Y08	DH01
AC07	DH02
AD07	DH03
V10	DH04
AB10	DH05
AB11	DH06
AC11	DH07
AA11	DH08
AE07	DH09
AE09	DH10
AE11	DH11
AB13	DH12
AA13	DH13
AD11	DH14
W11	DH15
V12	DH16
AB14	DH17
AC14	DH18
AB12	DH19
Y12	DH20
AB15	DH21
Y15	DH22

Signal Name List
(Part 3 of 9)

Pin	Signal
Y13	DH23
AC15	DH24
AA16	DH25
AD15	DH26
AE13	DH27
AD16	DH28
AB16	DH29
AE15	DH30
AE16	DH31
V01	DI1_N
V03	DI2_N
V11	DL00
AB06	DL01
AE05	DL02
R09	DL03
AC05	DL04
U11	DL05
AA07	DL06
AC06	DL07
AB07	DL08
T11	DL09
AD08	DL10
AB09	DL11
R11	DL12
T10	DL13
T09	DL14
Y09	DL15
V09	DL16
AC09	DL17
AB08	DL18
T12	DL19
Y10	DL20
Y11	DL21
AA09	DL22
AC18	DL23
AD18	DL24
AB18	DL25
AE18	DL26
AD19	DL27
AC19	DL28
AC17	DL29
AE17	DL30
AD17	DL31
W09	DP0/REQ2_N
AC10	DP1/REQ3_N
AD12	DP2/REQ4_N
AD05	DP3/REQ5_N
Y16	DP4/GNT4_N
AD13	DP5/GNT3_N
Y07	DP6/GNT4_N
AA15	DP7/GNT5_N
D19	DQM0
D03	ECC0
C03	ECC1/DQM1
D04	ECC2/DQM2

Signal Name List

(Part 4 of 9)

Pin	Signal
E04	ECC3/DQM3
B03	ECC4/DQM4
A03	ECC5/DQM5
B02	ECC6/DQM6
A02	ECC7/DQM7
N07	FRAME_N
N17	GBL_N
A19	GND
AA02	GND
AA08	GND
AA12	GND
AA18	GND
AD06	GND
AD10	GND
AD14	GND
AE01	GND
AE19	GND
B06	GND
B10	GND
B14	GND
E02	GND
E08	GND
E12	GND
E18	GND
F07	GND
G02	GND
G06	GND
G10	GND
G14	GND
J04	GND
J08	GND
J12	GND
J16	GND
L06	GND
L10	GND
L11	GND
L14	GND
M18	GND
N04	GND
N08	GND
N10	GND
N12	GND
N16	GND
R06	GND
R10	GND
R14	GND
U04	GND
U08	GND
U12	GND
U16	GND
W06	GND
W10	GND
W14	GND
M07	GNT0_N/REQ_N
K05	GNT1_N

Signal Name List

(Part 5 of 9)

Pin	Signal
L07	IDSEL
E03	IIC0_SCL
F04	IIC0_SDA
F02	IIC1_SCL
F03	IIC1_SDA
P04	IRDY_N
D01	IRQ0
G03	IRQ01
E01	IRQ02
H05	IRQ03
G05	IRQ04
G01	IRQ05
H02	IRQ06
L05	IRQ07
J03	IRQ08
K06	IRQ09
J05	IRQ10
K02	IRQ11
P13	IRQ_OUT_N
B15	M_DATA00
A16	M_DATA01
B16	M_DATA02
C15	M_DATA03
D15	M_DATA04
E15	M_DATA05
E16	M_DATA06
F15	M_DATA07
A15	M_DATA08
C14	M_DATA09
F14	M_DATA10
D14	M_DATA11
D13	M_DATA12
C13	M_DATA13
F13	M_DATA14
E13	M_DATA15
H11	M_DATA16
D11	M_DATA17
E11	M_DATA18
D12	M_DATA19
F12	M_DATA20
B12	M_DATA21
A13	M_DATA22
B13	M_DATA23
F11	M_DATA24
B11	M_DATA25
A11	M_DATA26
C11	M_DATA27
K11	M_DATA28
J11	M_DATA29
F10	M_DATA30
D10	M_DATA31
F08	M_DATA32
F09	M_DATA33
E09	M_DATA34
C09	M_DATA35

Signal Name List

(Part 6 of 9)

Pin	Signal
D09	M_DATA36
K10	M_DATA37
H10	M_DATA38
B09	M_DATA39
D08	M_DATA40
A09	M_DATA41
B08	M_DATA42
E07	M_DATA43
D07	M_DATA44
C07	M_DATA45
D06	M_DATA46
B07	M_DATA47
M10	M_DATA48
K08	M_DATA49
L09	M_DATA50
K09	M_DATA51
J09	M_DATA52
H09	M_DATA53
C05	M_DATA54
C06	M_DATA55
F05	M_DATA56
E05	M_DATA57
D05	M_DATA58
A07	M_DATA59
B05	M_DATA60
A05	M_DATA61
B04	M_DATA62
A04	M_DATA63
H18	MA00
H17	MA01
H16	MA02
F16	MA03
G17	MA04
F17	MA05
E17	MA06
F18	MA07
G19	MA08
E19	MA09
G18	MA10/AP
D17	MA11
H19	MA12
M16	MCP_N
N19	MCP_REQ
L03	PAR
L18	PCI_66_STRAP
H03	PCI_CLK
H01	PCIPLL_VDDA
M08	PERR_N
C19	RAS_N
K04	REQ0_N/GNT_N
M03	REQ1_N
L17	RESET_OUT_N
AC13	RI_N
H14	ROM_ALE
K12	ROM_OE_N

Signal Name List

(Part 7 of 9)

Pin	Signal
G15	ROM_RD_N
L13	ROM_READY
K16	ROM_RNW
L15	ROM_WE_N
K15	ROM_WR_N
K01	RST_N
M06	SERR_N
T04	STOP_N
M17	SYS_CLK
K19	SYS_RESET_N
M19	SYSPLL_VDDA
M13	TA_N
R19	TBST_N
P03	TCK
P17	TDI
K17	TDO
M15	TEST_ENABLE
K03	TMS
P06	TRDY_N
P19	TRST_N
P14	TS_N
P16	TSIZ0
N13	TSIZ1
N11	TSIZ2
R15	TT0
T18	TT1
T19	TT2
P15	TT3
R18	TT4
C01	UART0_RX
B01	UART0_TX
D02	UART1_RX
C02	UART1_TX
A06	UNUSED
A08	UNUSED
A10	UNUSED
A12	UNUSED
A14	UNUSED
AE06	UNUSED
AE08	UNUSED
AE10	UNUSED
AE12	UNUSED
AE14	UNUSED
D16	UNUSED
F01	UNUSED
F06	UNUSED
F19	UNUSED
G07	UNUSED
G09	UNUSED
G11	UNUSED
G13	UNUSED
H06	UNUSED
H07	UNUSED
H08	UNUSED
H12	UNUSED

Signal Name List

(Part 8 of 9)

Pin	Signal
H13	UNUSED
H15	UNUSED
J01	UNUSED
J07	UNUSED
J13	UNUSED
J15	UNUSED
J19	UNUSED
K07	UNUSED
K13	UNUSED
K14	UNUSED
L01	UNUSED
L19	UNUSED
R07	UNUSED
T06	UNUSED
T07	UNUSED
T13	UNUSED
U01	UNUSED
U05	UNUSED
U07	UNUSED
U09	UNUSED
U13	UNUSED
U15	UNUSED
U19	UNUSED
V06	UNUSED
V07	UNUSED
V08	UNUSED
V13	UNUSED
V14	UNUSED
W05	UNUSED
W07	UNUSED
W13	UNUSED
W15	UNUSED
Y01	UNUSED
Y06	UNUSED
Y14	UNUSED
Y19	UNUSED
AA03	VDD
AA06	VDD
AA10	VDD
AA14	VDD
AC04	VDD
AC08	VDD
AC12	VDD
AC16	VDD
C04	VDD
C08	VDD
C10	VDD
C12	VDD
C16	VDD
E06	VDD
E10	VDD
E14	VDD
G04	VDD
G08	VDD
G12	VDD

Signal Name List

(Part 9 of 9)

Pin	Signal
G16	VDD
H04	VDD
J02	VDD
J06	VDD
J10	VDD
J14	VDD
J18	VDD
L04	VDD
L08	VDD
L12	VDD
L16	VDD
M09	VDD
M11	VDD
N02	VDD
N06	VDD
N14	VDD
N18	VDD
P09	VDD
P11	VDD
P18	VDD
R04	VDD
R08	VDD
R12	VDD
R16	VDD
U02	VDD
U06	VDD
U10	VDD
U14	VDD
U18	VDD
W04	VDD
W08	VDD
W12	VDD
W16	VDD
D18	WE_N

4. Package Information

Package Dimensions (474-Pin CBGA Package)

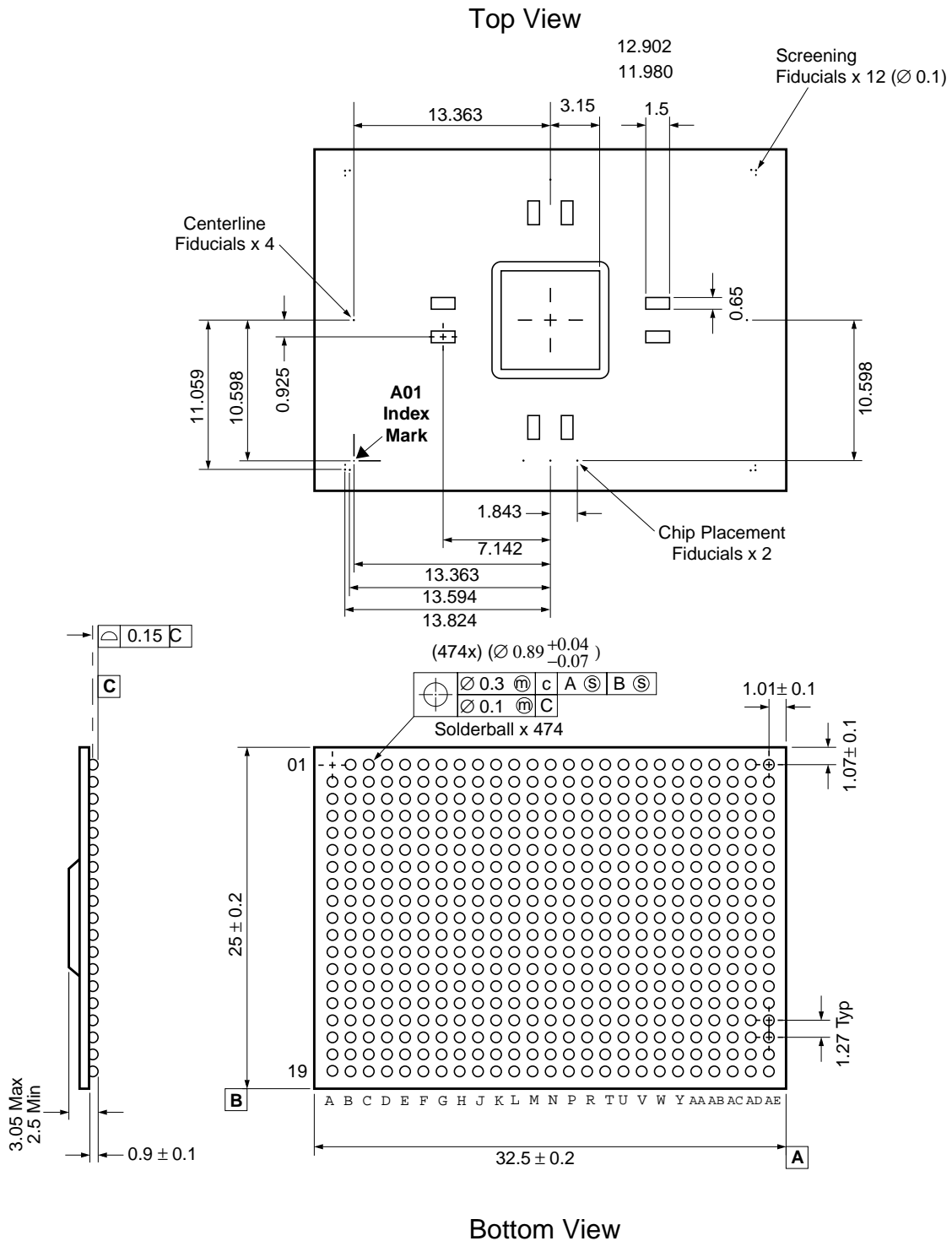

5. Ordering Information

Product Name	IBM Part Number	OEMLS Part Number	Processor Bus Frequency	Package	Rev Level
CPC700	45L7531	IBM25CPC700BB3B66	66.66	25x32MM (474) CBGA	dd 1.1
CPC700	45L7530	IBM25CPC700BB3B83	83.33	25x32MM (474) CBGA	dd 1.1

This section provides the part numbering nomenclature for the CPC700. For availability, contact your local IBM sales office.

IBM Part Number Key

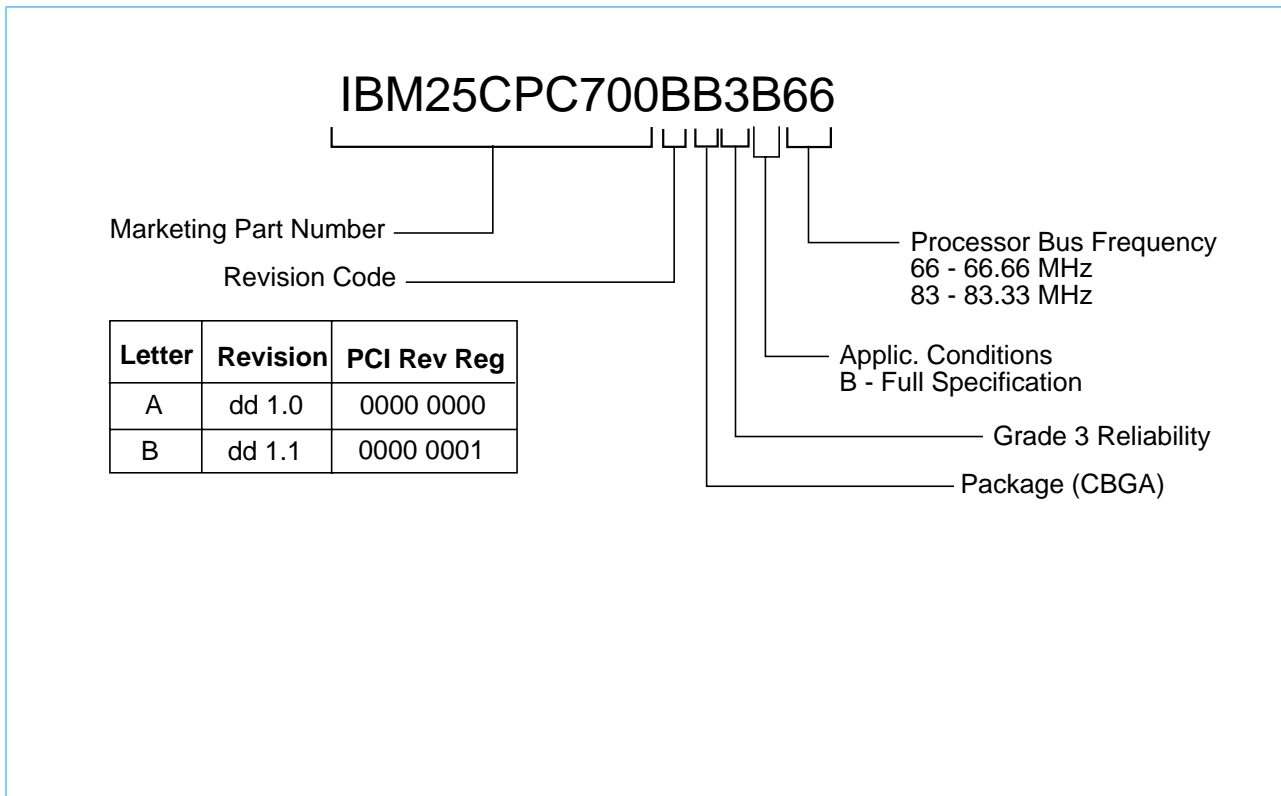

Copyright**Trademarks**

The following are trademarks of International Business Machines Corporation in the United States, or other countries, or both:

IBM

IBM Logo

PowerPC

AIX

CPC700

Other company, product, and service names may be trademarks or service marks of others.

Preliminary Edition (Version 3.0, 3/19/99 Preliminary)

This document contains information on a new product by IBM. IBM reserves the right to change or discontinue this product without notice.

© International Business Machines Corporation 1999.

Portions hereof ©International Business Machines Corporation, 1991-1999.

All rights reserved.