

512Mbit gDDR2 SDRAM

Revision 1.1
February 2007

Notice

INFORMATION IN THIS DOCUMENT IS PROVIDED IN RELATION TO SAMSUNG PRODUCTS, AND IS SUBJECT TO CHANGE WITHOUT NOTICE.

NOTHING IN THIS DOCUMENT SHALL BE CONSTRUED AS GRANTING ANY LICENSE, EXPRESS OR IMPLIED, BY ESTOPPEL OR OTHERWISE,

TO ANY INTELLECTUAL PROPERTY RIGHTS IN SAMSUNG PRODUCTS OR TECHNOLOGY. ALL INFORMATION IN THIS DOCUMENT IS PROVIDED

ON AS "AS IS" BASIS WITHOUT GUARANTEE OR WARRANTY OF ANY KIND.

1. For updates or additional information about Samsung products, contact your nearest Samsung office.
2. Samsung products are not intended for use in life support, critical care, medical, safety equipment, or similar applications where Product failure could result in loss of life or personal or physical harm, or any military or defense application, or any governmental procurement to which special terms or provisions may apply.

*** Samsung Electronics reserves the right to change products or specification without notice.**

Revision History

Revision	Month	Year	History
0.0	March	2006	- Target Spec
0.1	July	2006	- Modified package information(package dimension : 9mmx13mm)
0.2	October	2006	- Added current data for -ZC25(400MHz) & -ZC2A(350MHz) on page 9 - Changed the comment for tWR MRS data on page 22 - Corrected tAOND & tAOFD data on page 12
1.0	November	2006	Defined final specification - Added and changed current data
1.1	February	2007	- Changed VDD/VDDQ data for -ZC20(500MHz)/-ZC22(450MHz)

8M x 16Bit x 4 Banks graphic DDR2 Synchronous DRAM with Differential Data Strobe

1.0 FEATURES

- 1.8V \pm 0.1V power supply for device operation for -ZC25/2A
- 1.8V \pm 0.1V power supply for I/O interface for -ZC25/2A
- 1.9V \pm 0.1V power supply for device operation for -ZC20/22
- 1.9V \pm 0.1V power supply for I/O interface for -ZC20/22
- 4 Banks operation
- Posted $\overline{\text{CAS}}$
- Programmable $\overline{\text{CAS}}$ Latency : 5,6 ,7
- Programmable Additive Latency : 0, 1, 2, 3 , 4, 5
- Write Latency (WL) = Read Latency (RL) -1
- Burst Legth : 4 and 8 (Interleave/nibble sequential)
- Programmable Sequential/ Interleave Burst Mode
- Bi-directional Differential Data-Strobe
(Single-ended data-strobe is an optional feature)
- Off-chip Driver (OCD) Impedance Adjustment
- On Die Termination
- Refresh and Self Refresh
Average Refresh Period 7.8us at lower then $T_{\text{CASE}} 85\times\text{C}$,
3.9us at $85\times\text{C} < T_{\text{CASE}} \leq 95 \times\text{C}$

2.0 ORDERING INFORMATION

Part NO.	Max Freq.	Max Data Rate	VDD/VDDQ	Package
K4N51163QE-ZC20	500MHz	1000Mbps/pin	1.9V \pm 0.1V	84 Ball FBGA
K4N51163QE-ZC22	450MHz	900Mbps/pin		
K4N51163QE-ZC25	400MHz	800Mbps/pin	1.8V \pm 0.1V	
K4N51163QE-ZC2A	350MHz	700Mbps/pin		

* K4N51163QE-GC** is the Leaded package part number.

3.0 GENERAL DESCRIPTION FOR 8M x 16Bit x 4 Bank gDDR2 SDRAM

The 512Mb gDDR2 SDRAM chip is organized as 8Mbit x 16 I/O x 4banks banks device. This synchronous device achieve high speed graphic double-data-rate transfer rates of up to 800Mb/sec/pin for general applications. The chip is designed to comply with the following key gDDR2 SDRAM features such as posted CAS with additive latency, write latency = read latency - 1, Off-Chip Driver(OCD) impedance adjustment and On Die Termination. All of the control and address inputs are synchronized with a pair of externally supplied differential clocks. Inputs are latched at the cross point of differential clocks (CK rising and $\overline{\text{CK}}$ falling). All I/Os are synchronized with a pair of bidirectional strobes (DQS and $\overline{\text{DQS}}$) in a source synchronous fashion. A thirteen bit address bus is used to convey row, column, and bank address information in a $\overline{\text{RAS}}/\overline{\text{CAS}}$ multiplexing style. For example, 512Mb(x16) device receive 13/10/2 addressing. The 512Mb gDDR2 devices operate with a single 1.8V \pm 0.1V power supply and 1.8V \pm 0.1V VDDQ. The 512Mb gDDR2 devices are available in 84ball FBGAs(x16).

Note : The functionality described and the timing specifications included in this data sheet are for the DLL Enabled mode of operation.

4.0 PIN CONFIGURATION
Normal Package (Top View)

1	2	3		7	8	9
VDD	NC	VSS	A	VSSQ	\overline{UDQS}	VDDQ
DQ14	VSSQ	UDM	B	UDQS	VSSQ	DQ15
VDDQ	DQ9	VDDQ	C	VDDQ	UDQ0	VDDQ
DQ12	VSSQ	DQ11	D	DQ10	VSSQ	DQ13
VDD	NC	VSS	E	VSSQ	\overline{LDQS}	VDDQ
DQ6	VSSQ	LDM	F	LDQS	VSSQ	DQ7
VDDQ	DQ1	VDDQ	G	VDDQ	DQ0	VDDQ
DQ4	VSSQ	DQ3	H	DQ2	VSSQ	DQ5
VDDL	VREF	VSS	J	VSSDL	CK	VDD
	CKE	\overline{WE}	K	\overline{RAS}	\overline{CK}	ODT
NC	BA0	BA1	L	\overline{CAS}	\overline{CS}	
	A10/AP	A1	M	A2	A0	VDD
VSS	A3	A5	N	A6	A4	
	A7	A9	P	A11	A8	VSS
VDD	A12	NC	R	NC	NC	

Note :

1. VDDL and VSSDL are power and ground for the DLL.
2. In case of only 8 DQs out of 16 DQs are used, LDQS, LDQSB and DQ0-7 must be used.

Ball Locations (x16)

- : Populated Ball
- + : Depopulated Ball

Top View
 (See the balls through the Package)

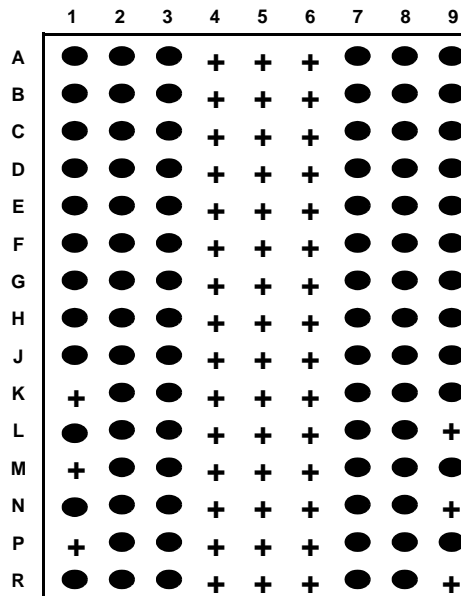

5.0 PACKAGE DIMENSIONS (84 Ball FBGA)

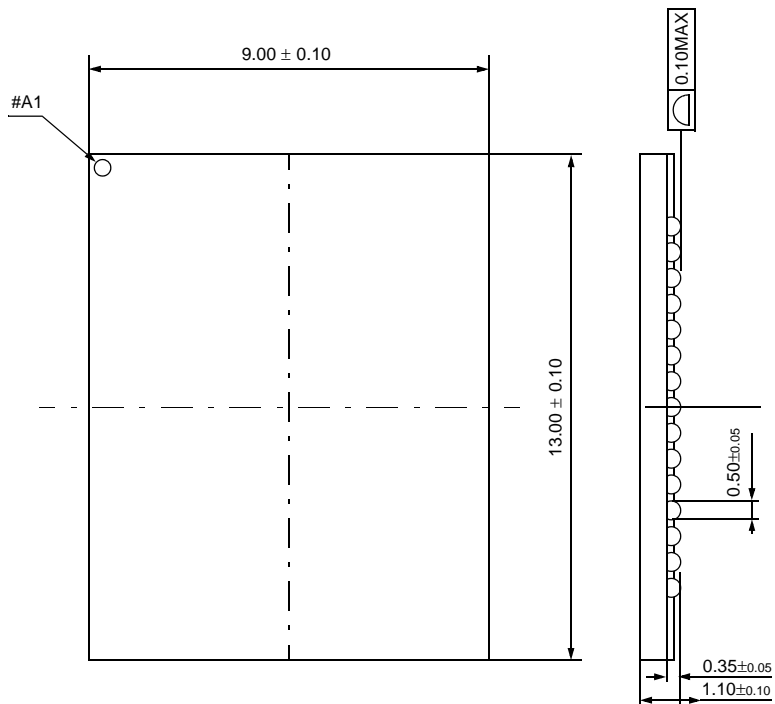
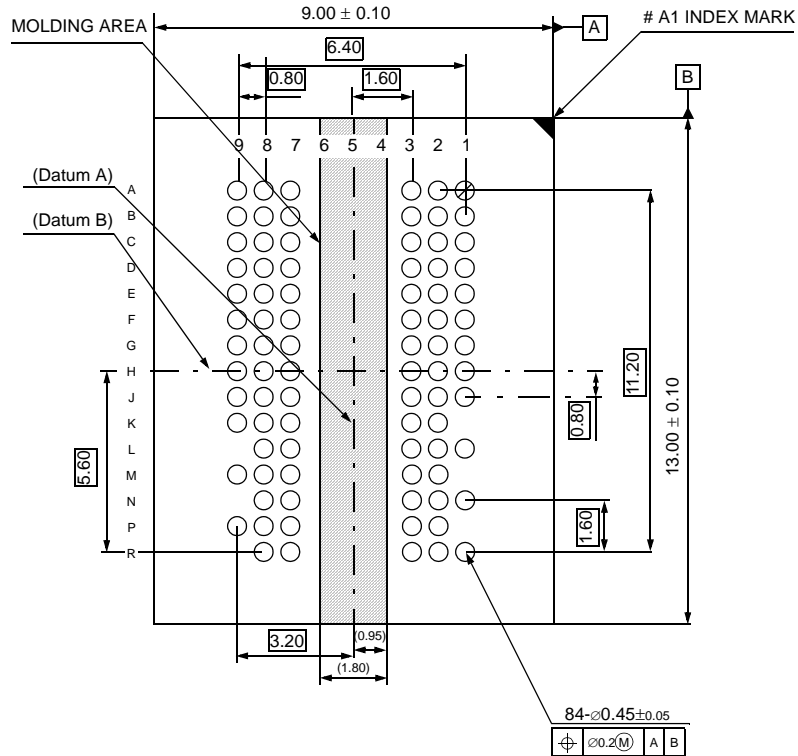

Unit : mm

6.0 INPUT/OUTPUT FUNCTIONAL DESCRIPTION

Symbol	Type	Function
CK, $\overline{\text{CK}}$	Input	Clock: CK and $\overline{\text{CK}}$ are differential clock inputs. CMD, ADD inputs are sampled on the crossing of the positive edge of CK and negative edge of $\overline{\text{CK}}$. Output (read) data is referenced to the crossings of CK and $\overline{\text{CK}}$ (both directions of crossing).
CKE	Input	Clock Enable: CKE HIGH activates, and CKE Low deactivates, internal clock signals and device input buffers and output drivers. Taking CKE Low provides Precharge Power-Down and Self Refresh operation (all banks idle), or Active Power-Down (row Active in any bank). CKE is synchronous for power down entry and exit, and for self refresh entry. CKE is asynchronous for self refresh exit. CKE must be maintained high throughout read and write accesses. Input buffers, excluding CK, $\overline{\text{CK}}$ and CKE are disabled during power-down. Input buffers, excluding CKE, are disabled during self refresh.
$\overline{\text{CS}}$	Input	Chip Select: All commands are masked when $\overline{\text{CS}}$ is registered HIGH. $\overline{\text{CS}}$ provides for external bank selection on systems with multiple banks. $\overline{\text{CS}}$ is considered part of the command code.
ODT	Input	On Die Termination: ODT (registered HIGH) enables termination resistance internal to the gDDR2 SDRAM. When enabled, ODT is only applied to each DQ, UDQS/ $\overline{\text{UDQS}}$, LDQS/ $\overline{\text{LDQS}}$, UDM, and LDM signal for x16 configurations. The ODT pin will be ignored if the Extended Mode Register (EMRS) is programmed to disable ODT.
RAS, $\overline{\text{CAS}}$, $\overline{\text{WE}}$	Input	Command Inputs: $\overline{\text{RAS}}$, $\overline{\text{CAS}}$ and $\overline{\text{WE}}$ (along with $\overline{\text{CS}}$) define the command being entered.
(L)UDM	Input	Input Data Mask: DM is an input mask signal for write data. Input data is masked when DM is sampled HIGH coincident with that input data during a Write access. DM is sampled on both edges of DQS. Although DM pins are input only, the DM loading matches the DQ and DQS loading.
BA0 - BA1	Input	Bank Address Inputs: BA0 and BA1 define to which bank an Active, Read, Write or Precharge command is being applied. BA0 also determines if the mode register or extended mode register is to be accessed during a MRS or EMRS cycle.
A0 - A12	Input	Address Inputs: Provided the row address for Active commands and the column address and Auto Precharge bit for Read/Write commands to select one location out of the memory array in the respective bank. A10 is sampled during a Precharge command to determine whether the Precharge applies to one bank (A10 LOW) or all banks (A10 HIGH). If only one bank is to be precharged, the bank is selected by BA0, BA1. The address inputs also provide the op-code during Mode Register Set commands.
DQ	Input/ Output	Data Input/ Output: Bi-directional data bus.
LDQS, ($\overline{\text{LDQS}}$) UDQS, ($\overline{\text{UDQS}}$)	Input/ Output	Data Strobe: output with read data, input with write data. Edge-aligned with read data, centered in write data. LDQS corresponds to the data on DQ0-DQ7; UDQS corresponds to the data on DQ8-DQ15. The data strobes LDQS and UDQS may be used in single ended mode or paired with optional complementary signals $\overline{\text{LDQS}}$ and $\overline{\text{UDQS}}$ to provide differential pair signaling to the system during both reads and writes. An EMRS(1) control bit enables or disables all complementary data strobe signals.
NC/RFU		No Connect: No internal electrical connection is present.
V _{DDQ}	Supply	DQ Power Supply: 1.8V ± 0.1V
V _{SSQ}	Supply	DQ Ground
V _{DDL}	Supply	DLL Power Supply: 1.8V ± 0.1V
V _{SSL}	Supply	DLL Ground
V _{DD}	Supply	Power Supply: 1.8V ± 0.1V
V _{SS}	Supply	Ground
V _{REF}	Supply	Reference voltage

7.0 ABSOLUTE MAXIMUM DC RATINGS

Symbol	Parameter	Rating	Units	Notes
VDD	Voltage on VDD pin relative to Vss	- 1.0 V ~ 2.3 V	V	1
VDDQ	Voltage on VDDQ pin relative to Vss	- 0.5 V ~ 2.3 V	V	1
VDDL	Voltage on VDDL pin relative to Vss	- 0.5 V ~ 2.3 V	V	1
V _{IN} , V _{OUT}	Voltage on any pin relative to Vss	- 0.5 V ~ 2.3 V	V	1
T _{STG}	Storage Temperature	-55 to +100	°C	1, 2

Note :

- Stresses greater than those listed under "Absolute Maximum Ratings" may cause permanent damage to the device. This is a stress rating only and functional operation of the device at these or any other conditions above those indicated in the operational sections of this specification is not implied. Exposure to absolute maximum rating conditions for extended periods may affect reliability.
- Storage Temperature is the case surface temperature on the center/top side of the DRAM. For the measurement conditions, please refer to JEDEC51-2 standard.

8.0 AC & DC OPERATING CONDITIONS

8.1 Recommended DC Operating Conditions (SSTL - 1.8)

Symbol	Parameter	Rating			Units	Notes
		Min.	Typ.	Max.		
VDD	Supply Voltage	1.7	1.8	1.9	V	5
VDDL	Supply Voltage for DLL	1.7	1.8	1.9	V	4,5
VDDQ	Supply Voltage for Output	1.7	1.8	1.9	V	4,5
VREF	Input Reference Voltage	0.49*VDDQ	0.50*VDDQ	0.51*VDDQ	mV	1,2
VTT	Termination Voltage	VREF-0.04	VREF	VREF+0.04	V	3

Note : There is no specific device VDD supply voltage requirement for SSTL-1.8 compliance. However under all conditions VDDQ must be less than or equal to VDD.

- The value of VREF may be selected by the user to provide optimum noise margin in the system. Typically the value of VREF is expected to be about 0.5 x VDDQ of the transmitting device and VREF is expected to track variations in VDDQ.
- Peak to peak AC noise on VREF may not exceed +/-2% VREF(DC).
- VTT of transmitting device must track VREF of receiving device.
- AC parameters are measured with VDD, VDDQ and VDDL tied together.
- VDD/VDDQ/VDDL for -ZC20/22 = 1.9V ± 0.1V.

8.2 Operating Temperature Condition

Symbol	Parameter	Rating	Units	Note
TOPER	Operating Temperature	0 to 95	°C	1, 2, 3

Note :

- Operating Temperature is the case surface temperature on the center/top side of the DRAM. For the measurement conditions, please refer to JEDEC51.2 standard.
- At 0 - 85 °C, operation temperature range are the temperature which all DRAM specification will be supported.
- At 85 - 95 °C operation temperature range, doubling refresh commands in frequency to a 32ms period (tREFI=3.9 us) is required, and to enter to self refresh mode at this temperature range, an EMRS command is required to change internal refresh rate.

8.3 Input DC & AC Logic Level

Input DC Logic Level

Symbol	Parameter	Min.	Max.	Units	Note
V _{IH} (DC)	DC input logic high	V _{REF} + 0.125	V _{DDQ} + 0.3	V	
V _{IL} (DC)	DC input logic low	V _{DDQ} - 0.3	V _{REF} - 0.125	V	

Input AC Logic Level

Symbol	Parameter	Min.	Max.	Units	Note
V _{IH} (AC)	AC input logic high	V _{REF} + 0.250	-	V	
V _{IL} (AC)	AC input logic low	-	V _{REF} - 0.250	V	

8.4 AC Input Test Conditions

Symbol	Condition	Value	Units	Note
V _{REF}	Input reference voltage	0.5 * V _{DDQ}	V	1
V _{SWING(MAX)}	Input signal maximum peak to peak swing	1.0	V	1
SLEW	Input signal minimum slew rate	1.0	V/ns	2, 3

Note :

1. Input waveform timing is referenced to the input signal crossing through the V_{IH/IL(AC)} level applied to the device under test.
2. The input signal minimum slew rate is to be maintained over the range from V_{REF} to V_{IH(AC)} min for rising edges and the range from V_{REF} to V_{IL(AC)} max for falling edges as shown in the below figure.
3. AC timings are referenced with input waveforms switching from V_{IL(AC)} to V_{IH(AC)} on the positive transitions and V_{IH(AC)} to V_{IL(AC)} on the negative transitions.

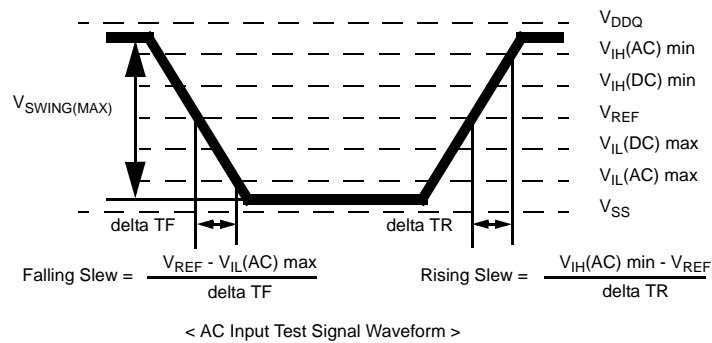

8.5 Differential input AC logic Level

Symbol	Parameter	Min.	Max.	Units	Note
V _{ID(AC)}	AC differential input voltage	0.5	V _{DDQ} + 0.6	V	1
V _{I_X(AC)}	AC differential cross point voltage	0.5 * V _{DDQ} - 0.175	0.5 * V _{DDQ} + 0.175	V	2

Note :

1. V_{ID(AC)} specifies the input differential voltage |V_{TR} - V_{CP}| required for switching, where V_{TR} is the true input signal (such as CK, DQS, LDQS or UDQS) and V_{CP} is the complementary input signal (such as CK, DQS, LDQS or UDQS). The minimum value is equal to V_{IH(AC)} - V_{IL(AC)}.
2. The typical value of V_{I_X(AC)} is expected to be about 0.5 * V_{DDQ} of the transmitting device and V_{I_X(AC)} is expected to track variations in V_{DDQ}. V_{I_X(AC)} indicates the voltage at which differential input signals must cross.

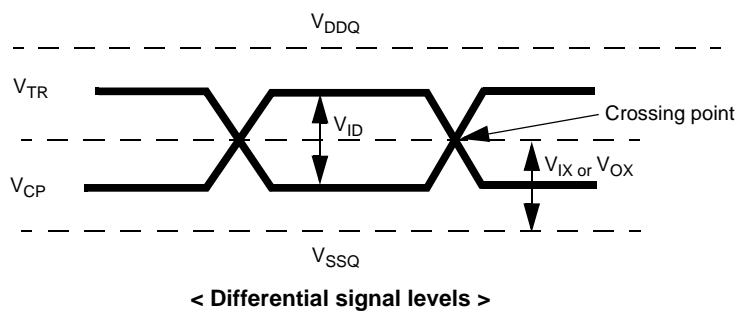

8.6 Differential AC output parameters

Symbol	Parameter	Min.	Max.	Units	Note
V _{O_X(AC)}	AC differential cross point voltage	0.5 * V _{DDQ} - 0.125	0.5 * V _{DDQ} + 0.125	V	1

Note :

1. The typical value of V_{O_X(AC)} is expected to be about 0.5 * V_{DDQ} of the transmitting device and V_{O_X(AC)} is expected to track variations in V_{DDQ}. V_{O_X(AC)} indicates the voltage at which differential output signals must cross.

8.7 OCD default characteristics

Description	Parameter	Min	Nom	Max	Unit	Note
Output impedance		Normal 18ohms See full strength default driver characteristics			ohms	1,2
Output impedance step size for OCD calibration		0		1.5	ohms	6
Pull-up and pull-down mismatch		0		4	ohms	1,2,3
Output slew rate	Sout	1.5		5	V/ns	1,4,5,6,7,8

Notes:

1. Absolute Specifications ($0^{\circ}\text{C} \leq T_{\text{CASE}} \leq +95^{\circ}\text{C}$; $V_{\text{DD}} = +1.8\text{V} \pm 0.1\text{V}$, $V_{\text{DDQ}} = +1.8\text{V} \pm 0.1\text{V}$)
2. Impedance measurement condition for output source dc current: $V_{\text{DDQ}} = 1.7\text{V}$; $V_{\text{OUT}} = 1420\text{mV}$; $(V_{\text{OUT}} - V_{\text{DDQ}}) / I_{\text{oh}}$ must be less than 23.4 ohms for values of V_{OUT} between V_{DDQ} and $V_{\text{DDQ}} - 280\text{mV}$. Impedance measurement condition for output sink dc current: $V_{\text{DDQ}} = 1.7\text{V}$; $V_{\text{OUT}} = 280\text{mV}$; $V_{\text{OUT}} / I_{\text{ol}}$ must be less than 23.4 ohms for values of V_{OUT} between 0V and 280mV .
3. Mismatch is absolute value between pull-up and pull-dn, both are measured at same temperature and voltage.
4. Slew rate measured from $V_{\text{IL}}(\text{AC})$ to $V_{\text{IH}}(\text{AC})$.
5. The absolute value of the slew rate as measured from DC to DC is equal to or greater than the slew rate as measured from AC to AC. This is guaranteed by design and characterization.
6. This represents the step size when the OCD is near 18 ohms at nominal conditions across all process and represents only the DRAM uncertainty.

Output slew rate load :

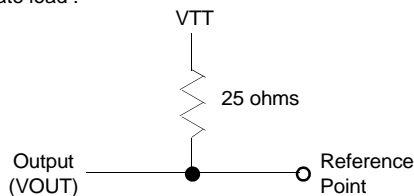

7. DRAM output slew rate specification applies to 533Mb/sec/pin, 667Mb/sec/pin, 800Mb/sec/pin, 900Mbps/sec/pin and 1000Mbps/sec/pin speed bins.
8. Timing skew due to DRAM output slew rate mis-match between $\overline{\text{DQS}} / \overline{\text{DQS}}$ and associated DQs is included in t_{DQSQ} and t_{QHS} specification.

8.8 DC characteristics

(Recommended operating conditions unless otherwise noted, $0^{\circ}\text{C} \leq T_c \leq 85^{\circ}\text{C}$)

Parameter	Symbol	Test Condition	Version				Unit	
			-20	-22	-25	-2A		
Operating Current (One Bank Active)	ICC1	Burst Length=4 $t_{\text{RC}} \geq t_{\text{RC}}(\text{min})$. $I_{\text{OL}}=0\text{mA}$, $t_{\text{CC}}= t_{\text{CC}}(\text{min})$. DQ,DM,DQS inputs changing twice per clock cycle. Address and control inputs changing once per clock cycle	125	120	115	110	mA	
Precharge Standby Current in Power-down mode	ICC2P	$\text{CKE} \leq V_{\text{IL}}(\text{max})$, $t_{\text{CC}}= t_{\text{CC}}(\text{min})$	8	8	8	8	mA	
Precharge Standby Current in Non Power-down mode	ICC2N	$\text{CKE} \geq V_{\text{IH}}(\text{min})$, $\overline{\text{CS}} \geq V_{\text{IH}}(\text{min})$, $t_{\text{CC}}= t_{\text{CC}}(\text{min})$ Address and control inputs changing once per clock cycle	40	40	40	40	mA	
Active Standby Current power-down mode	ICC3P	$\text{CKE} \leq V_{\text{IL}}(\text{max})$, $t_{\text{CC}}= t_{\text{CC}}(\text{min})$	Fast PDN Exit $\text{MRS}(12) = 0\text{mA}$	35	35	30	30	mA
			Slow PDN Exit $\text{MRS}(12) = 1\text{mA}$					
Active Standby Current in in Non Power-down mode	ICC3N	$\text{CKE} \geq V_{\text{IH}}(\text{min})$, $\overline{\text{CS}} \geq V_{\text{IH}}(\text{min})$, $t_{\text{CC}}= t_{\text{CC}}(\text{min})$ DQ,DM,DQS inputs changing twice per clock cycle. Address and control inputs changing once per clock cycle	60	60	60	55	mA	
Operating Current (Burst Mode)	ICC4	$I_{\text{OL}}=0\text{mA}$, $t_{\text{CC}}= t_{\text{CC}}(\text{min})$, Page Burst, All Banks activated. DQ,DM,DQS inputs changing twice per clock cycle. Address and control inputs changing once per clock.	220	200	190	170	mA	
Refresh Current	ICC5	$t_{\text{RC}} \geq t_{\text{RFC}}$	140	130	120	110	mA	
Self Refresh Current	ICC6	$\text{CKE} \leq 0.2\text{V}$	8	8	8	8	mA	
Operating Current (4Bank interleaving)	ICC7	Burst Length=4 $t_{\text{RC}} \geq t_{\text{RC}}(\text{min})$. $I_{\text{OL}}=0\text{mA}$, $t_{\text{CC}}= t_{\text{CC}}(\text{min})$. DQ,DM,DQS inputs changing twice per clock cycle. Address and control inputs changing once per clock cycle	340	300	280	250	mA	

Note :

1. Measured with outputs open and ODT off

8.9 Input/Output capacitance

Parameter	Symbol	-20		-22		- 2A		- 25		Units
		Min	Max	Min	Max	Min	Max	Min	Max	
Input capacitance, CK and \overline{CK}	CCK	1.0	2.0	1.0	2.0	1.0	2.0	1.0	2.0	pF
Input capacitance delta, CK and \overline{CK}	CDCK	x	0.25	x	0.25	x	0.25	x	0.25	pF
Input capacitance, all other input-only pins	CI	1.0	2.0	1.0	2.0	1.0	2.0	1.0	1.75	pF
Input capacitance delta, all other input-only pins	CDI	x	0.25	x	0.25	x	0.25	x	0.25	pF
Input/output capacitance, DQ, DM, DQS, \overline{DQS}	CIO	2.5	3.5	2.5	3.5	2.5	3.5	2.5	3.5	pF
Input/output capacitance delta, DQ, DM, DQS, \overline{DQS}	CDIO	x	0.5	x	0.5	x	0.5	x	0.5	pF

9.0 Electrical Characteristics & AC Timing for - 20/22/25/2A

(0 °C ≤ T_{CASE} ≤ 95 °C; V_{DD}/V_{DDQ} = 1.8V ± 0.1V for -25/2A, V_{DD}/V_{DDQ} = 1.9V ± 0.1V for -20/22)

9.1 Refresh Parameters

Parameter	Symbol	512Mb	Units
Refresh to active/Refresh command time	tRFC	105	ns
Average periodic refresh interval	tREFI	0 °C ≤ T _{CASE} ≤ 85°C	7.8
		85 °C < T _{CASE} ≤ 95°C	3.9

9.2 Speed Bins and CL, tRCD, tRP, tRC and tRAS

SPEED	-20	- 22	-25	- 2A	Units
Bin (CL-tRCD-tRP)	7-7-7	6-7-7	6-6-6	5-5-5	
Parameter	min	min	min	min	
CAS LATENCY	7	6	6	5	tCK
tCK	2.0	2.2	2.5	2.86	ns
tRCD	7	7	6	5	tCK
tRP	7	7	6	5	tCK
tRC	28	28	22	18	tCK
tRAS	21	21	16	13	tCK

9.3 Timing Parameters by Speed Grade

(Refer to notes for informations related to this table at the bottom)

Parameter	Symbol	- 20		- 22		- 25		- 2A		Units	Notes
		min	max	min	max	min	max	min	max		
DQ output access time from CK/ $\overline{\text{CK}}$	tAC	-350	+350	-350	+350	-400	+400	-450	+450	ps	
DQS output access time from CK/ $\overline{\text{CK}}$	tDQSK	-300	+300	-300	+300	-350	+350	-400	+400	ps	
CK high-level width	tCH	0.45	0.55	0.45	0.55	0.45	0.55	0.45	0.55	tCK	
CK low-level width	tCL	0.45	0.55	0.45	0.55	0.45	0.55	0.45	0.55	tCK	
CK half period	tHP	min(tCL, tCH)	x	min(tCL, tCH)	x	min(tCL, tCH)	x	min(tCL, tCH)	x	ps	20,21
Clock cycle time, CL= x	tCK	2.0	8.0	2.2	8.0	2.5	8.0	2.86	8.0	ns	24
DQ and DM input hold time	tDH	175	x	175	x	175	x	175	x	ps	15,16, 17
DQ and DM input setup time	tDS	50	x	50	x	50	x	50	x	ps	15,16, 17
Control & Address input pulse width for each input	tIPW	0.6	x	0.6	x	0.6	x	0.6	x	tCK	
DQ and DM input pulse width for each input	tDIPW	0.35	x	0.35	x	0.35	x	0.35	x	tCK	
Data-out high-impedance time from CK/ $\overline{\text{CK}}$	tHZ	x	tAC max	x	tAC max	x	tAC max	x	tAC max	ps	
DQS low-impedance time from CK/ $\overline{\text{CK}}$	tLZ (DQS)	tAC min	tAC max	tAC min	tAC max	tAC min	tAC max	tAC min	tAC max	ps	27
DQ low-impedance time from CK/ $\overline{\text{CK}}$	tLZ(DQ)	2*tAC min	tAC max	2*tAC min	tAC max	2*tAC min	tAC max	2*tAC min	tAC max	ps	27
DQS-DQ skew for DQS and associated DQ signals	tDQSQ	x	280	x	280	x	280	x	310	ps	22
DQ hold skew factor	tQHS	x	380	x	380	x	380	x	410	ps	21
DQ/DQS output hold time from DQS	tQH	tHP - tQHS	x	tHP - tQHS	x	tHP - tQHS	x	tHP - tQHS	x	ps	
Write command to first DQS latching transition	tDQSS	WL -0.25	WL +0.25	WL -0.25	WL +0.25	WL -0.25	WL +0.25	WL -0.25	WL +0.25	tCK	
DQS input high pulse width	tDQSH	0.35	x	0.35	x	0.35	x	0.35	x	tCK	
DQS input low pulse width	tDQSL	0.35	x	0.35	x	0.35	x	0.35	x	tCK	
DQS falling edge to CK setup time	tDSS	0.2	x	0.2	x	0.2	x	0.2	x	tCK	
DQS falling edge hold time from CK	tDSH	0.2	x	0.2	x	0.2	x	0.2	x	tCK	
Mode register set command cycle time	tMRD	2	x	2	x	2	x	2	x	tCK	
Write postamble	tWPST	0.4	0.6	0.4	0.6	0.4	0.6	0.4	0.6	tCK	19
Write preamble	tWPRE	0.35	x	0.35	x	0.35	x	0.35	x	tCK	
Address and control input hold time	tIH	200	x	200	x	250	x	325	x	ps	14,16, 18
Address and control input setup time	tIS	150	x	150	x	175	x	200	x	ps	14,16, 18
Read preamble	tRPRE	0.9	1.1	0.9	1.1	0.9	1.1	0.9	1.1	tCK	28
Read postamble	tRPST	0.4	0.6	0.4	0.6	0.4	0.6	0.4	0.6	tCK	28
Active to active command period	tRRD	7.5	x	7.5	x	7.5	x	7.5	x	ns	12

Parameter	Symbol	- 20		- 22		-25		- 2A		Units	Notes
		min	max	min	max	min	max	min	max		
CAS to CAS command delay	tCCD	2		2		2		2		tCK	
Write recovery time	tWR	6	x	6	x	6	x	5	x	tCK	
Auto precharge write recovery + pre-charge time	tDAL	WR+tRP	x	tWR+tRP	x	WR+tRP	x	tWR+tRP	x	tCK	23
Internal write to read command delay	tWTR	4		4	x	3		3	x	tCK	
Internal read to precharge command delay	tRTP	4		4		3		3		tCK	11
Exit self refresh to a non-read command	tXSNR	tRFC + 10		tRFC + 10		tRFC + 10		tRFC + 10		ns	
Exit self refresh to a read command	tXSRD	200		200		200		200		tCK	
Exit precharge power down to any non-read command	tXP	2	x	2	x	2	x	2	x	tCK	
Exit active power down to read command	tXARD	2	x	2	x	2	x	2	x	tCK	9
Exit active power down to read command (Slow exit, Lower power)	tXARDS	6 - AL		6 - AL		6 - AL		6 - AL		tCK	9, 10
CKE minimum pulse width (high and low pulse width)	tCKE	3		3		3		3		tCK	
ODT turn-on delay	tAOND	2	2	2	2	2	2	2	2	tCK	
ODT turn-on	tAON	tAC(min)	tAC(max)+0.7	tAC(min)	tAC(max)+0.7	tAC(min)	tAC(max)+0.7	tAC(min)	tAC(max)+0.7	ns	13, 25
ODT turn-on(Power-Down mode)	tAONPD	tAC(min)+2	2tCK+tAC(max)+1	tAC(min)+2	2tCK+tAC(max)+1	tAC(min)+2	2tCK+tAC(max)+1	tAC(min)+2	2tCK+tAC(max)+1	ns	
ODT turn-off delay	tAOFD	2.5	2.5	2.5	2.5	2.5	2.5	2.5	2.5	tCK	
ODT turn-off	tAOF	tAC(min)	tAC(max)+0.6	tAC(min)	tAC(max)+0.6	tAC(min)	tAC(max)+0.6	tAC(min)	tAC(max)+0.6	ns	26
ODT turn-off (Power-Down mode)	tAOFPD	tAC(min)+2	2.5tCK+tAC(max)+1	tAC(min)+2	2.5tCK+tAC(max)+1	tAC(min)+2	2.5tCK+tAC(max)+1	tAC(min)+2	2.5tCK+tAC(max)+1	ns	
ODT to power down entry latency	tANPD	3		3		3		3		tCK	
ODT power down exit latency	tAXPD	8		8		8		8		tCK	
OCD drive mode output delay	tOIT	0	12	0	12	0	12	0	12	ns	
Minimum time clocks remains ON after CKE asynchronously drops LOW	tDelay	tIS+tCK+tIH		tIS+tCK+tIH		tIS+tCK+tIH		tIS+tCK+tIH		ns	24

Note : General notes, which may apply for all AC parameters

1. Slew Rate Measurement Levels

- Output slew rate for falling and rising edges is measured between $V_{TT} - 250$ mV and $V_{TT} + 250$ mV for single ended signals. For differential signals (e.g. $DQS - \overline{DQS}$) output slew rate is measured between $DQS - \overline{DQS} = -500$ mV and $DQS - \overline{DQS} = +500$ mV. Output slew rate is guaranteed by design, but is not necessarily tested on each device.
- Input slew rate for single ended signals is measured from dc-level to ac-level: from $V_{REF} - 125$ mV to $V_{REF} + 250$ mV for rising edges and from $V_{REF} + 125$ mV and $V_{REF} - 250$ mV for falling edges. For differential signals (e.g. $CK - \overline{CK}$) slew rate for rising edges is measured from $CK - \overline{CK} = -250$ mV to $CK - \overline{CK} = +500$ mV (250mV to -500 mV for falling edges).
- VID is the magnitude of the difference between the input voltage on CK and the input voltage on \overline{CK} , or between DQS and \overline{DQS} for differential strobe.

2. gDDR2 SDRAM AC timing reference load

Following figure represents the timing reference load used in defining the relevant timing parameters of the part. It is not intended to be either a precise representation of the typical system environment or a depiction of the actual load presented by a production tester. System designers will use IBIS or other simulation tools to correlate the timing reference load to a system environment. Manufacturers will correlate to their production test conditions (generally a coaxial transmission line terminated at the tester electronics).

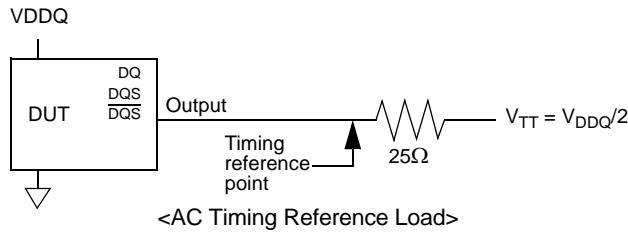

The output timing reference voltage level for single ended signals is the crosspoint with VTT. The output timing reference voltage level for differential signals is the crosspoint of the true (e.g. DQS) and the complement (e.g. \overline{DQS}) signal.

3. gDDR2 SDRAM output slew rate test load

Output slew rate is characterized under the test conditions as shown in the following figure.

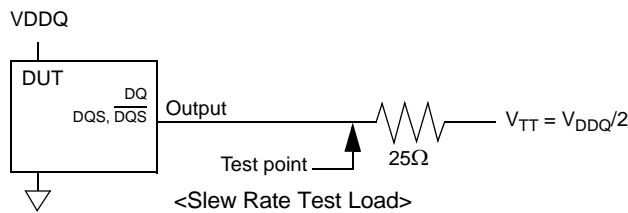

4. Differential data strobe

gDDR2 SDRAM pin timings are specified for either single ended mode or differential mode depending on the setting of the EMRS "Enable DQS" mode bit; timing advantages of differential mode are realized in system design. The method by which the gDDR2 SDRAM pin timings are measured is mode dependent. In single ended mode, timing relationships are measured relative to the rising or falling edges of DQS crossing at VREF. In differential mode, these timing relationships are measured relative to the crosspoint of DQS and its complement, \overline{DQS} . This distinction in timing methods is guaranteed by design and characterization. Note that when differential data strobe mode is disabled via the EMRS, the complementary pin, \overline{DQS} , must be tied externally to VSS through a 20 ohm to 10 K ohm resistor to insure proper operation.

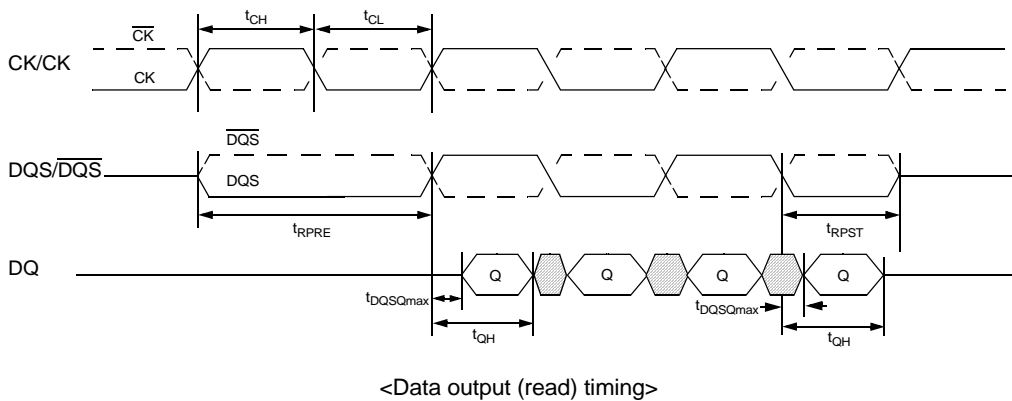
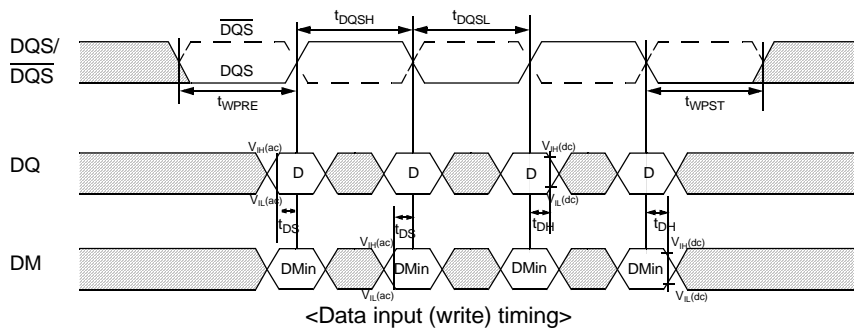

- 5. AC timings are for linear signal transitions.
- 6. These parameters guarantee device behavior, but they are not necessarily tested on each device. They may be guaranteed by device design or tester correlation.
- 7. All voltages are referenced to VSS.
- 8. Tests for AC timing, IDD, and electrical (AC and DC) characteristics, may be conducted at nominal reference/supply voltage levels, but the related specifications and device operation are guaranteed for the full voltage range specified.

: Specific Notes for dedicated AC parameters

- 9. User can choose which active power down exit timing to use via MRS(bit 12). tXARD is expected to be used for fast active power down exit timing. tXARDS is expected to be used for slow active power down exit timing.
- 10. AL = Additive Latency
- 11. This is a minimum requirement. Minimum read to precharge timing is AL + BL/2 providing the tRTP and tRAS(min) have been satisfied.
- 12. A minimum of two clocks (2 * tCK) is required irrespective of operating frequency
- 13. Timings are guaranteed with command/address input slew rate of 1.0 V/ns.
- 14. These parameters guarantee device behavior, but they are not necessarily tested on each device. They may be guaranteed by device design or tester correlation.
- 15. Timings are guaranteed with data, mask, and (DQS in singled ended mode) input slew rate of 1.0 V/ns.
- 16. Timings are guaranteed with CK/CK differential slew rate of 2.0 V/ns. Timings are guaranteed for DQS signals with a differential slew rate of 2.0 V/ns in differential strobe mode and a slew rate of 1V/ns in single ended mode.
- 17. tDS and tDH (data setup and hold) derating
 - 1) Input waveform timing is referenced from the input signal crossing at the $V_{IH}(AC)$ level for a rising signal and $V_{IL}(AC)$ for a falling signal applied to the device under test.
 - 2) Input waveform timing is referenced from the input signal crossing at the $V_{IH}(DC)$ level for a rising signal and $V_{IL}(DC)$ for a falling signal applied to the device under test.

ΔtDS, ΔtDH Derating Values (ALL units in 'ps', Note 1 applies to entire Table)																			
		DQS, DQS Differential Slew Rate																	
		4.0 V/ns		3.0 V/ns		2.0 V/ns		1.8 V/ns		1.6 V/ns		1.4V/ns		1.2V/ns		1.0V/ns		0.8V/ns	
		ΔtDS	ΔtDH	ΔtDS	ΔtDH	ΔtDS	ΔtDH	ΔtDS	ΔtDH	ΔtDS	ΔtDH	ΔtDS	ΔtDH	ΔtDS	ΔtDH	ΔtDS	ΔtDH	ΔtDS	ΔtDH
DQ Slew rate V/ns	2.0	100	45	100	45	100	45	-	-	-	-	-	-	-	-	-	-	-	-
	1.5	67	21	67	21	67	21	79	33	-	-	-	-	-	-	-	-	-	-
	1.0	0	0	0	0	0	0	12	12	24	24	-	-	-	-	-	-	-	-
	0.9	-	-	-5	-14	-5	-14	7	-2	19	10	31	22	-	-	-	-	-	-
	0.8	-	-	-	-	-13	-31	-1	-19	11	-7	23	5	35	17	-	-	-	-
	0.7	-	-	-	-	-	-	-10	-42	2	-30	14	-18	26	-6	38	6	-	-
	0.6	-	-	-	-	-	-	-	-	-10	-59	2	-47	14	-35	26	-23	38	-11
	0.5	-	-	-	-	-	-	-	-	-	-	-24	-89	-12	-77	0	-65	12	-53
0.4	-	-	-	-	-	-	-	-	-	-	-	-	-52	-140	-40	-128	-28	-116	

For all input signals the total tDS (setup time) and tDH(hold time) required is calculated by adding the datasheet tDS(base) and tDH(base) value to the delta tDS and delta tDH derating value respectively. Example : tDS (total setup time) = tDS(base) + delta tDS.

18. tIS and tIH (input setup and hold) derating

- 1) Input waveform timing is referenced from the input signal crossing at the $V_{IH}(AC)$ level for a rising signal and $V_{IL}(AC)$ for a falling signal applied to the device under test.
- 2) Input waveform timing is referenced from the input signal crossing at the $V_{IH}(DC)$ level for a rising signal and $V_{IL}(DC)$ for a falling signal applied to the device under test.

		ΔtIS and ΔtIH Derating Values						Units	Notes
		CK,CK Differential Slew Rate							
		2.0 V/ns		1.5 V/ns		1.0 V/ns			
		ΔtIS	ΔtIH	ΔtIS	ΔtIH	ΔtIS	ΔtIH		
Command /Adress Slew rate(V/ns)	4.0	+150	+94	+180	+124	+210	+154	ps	1
	3.5	+143	+89	+173	+119	+203	+149	ps	1
	3.0	+133	+83	+163	+113	+193	+143	ps	1
	2.5	+120	+75	+150	+105	+180	+135	ps	1
	2.0	+100	+45	+130	+75	+160	+105	ps	1
	1.5	+67	+21	+97	+51	+127	+81	ps	1
	1.0	0	0	+30	+30	+60	+60	ps	1
	0.9	-5	-14	+25	+16	+55	+46	ps	1
	0.8	-13	-31	+17	-1	+47	29	ps	1
	0.7	-22	-54	+8	-24	+38	+6	ps	1
	0.6	-34	-83	-4	-53	+26	-23	ps	1
	0.5	-60	-125	-30	-95	0	-65	ps	1
	0.4	-100	-188	-70	-158	-40	-128	ps	1
	0.3	-168	-292	-138	-262	-108	-232	ps	1
	0.25	-200	-375	-170	-345	-140	-315	ps	1
	0.2	-325	-500	-295	-470	-265	-440	ps	1
0.15	-517	-708	-487	-678	-457	-648	ps	1	
0.1	-1000	-1125	-970	-1095	-940	-1065			

19. The maximum limit for this parameter is not a device limit. The device will operate with a greater value for this parameter, but system performance (bus turnaround) will degrade accordingly.
20. MIN (tCL, tCH) refers to the smaller of the actual clock low time and the actual clock high time as provided to the device (i.e. this value can be greater than the minimum specification limits for tCL and tCH). For example, tCL and tCH are = 50% of the period, less the half period jitter (tJIT(HP)) of the clock source, and less the half period jitter due to crosstalk (tJIT(crosstalk)) into the clock traces.
21. tQH = tHP – tQHS, where:
 tHP = minimum half clock period for any given cycle and is defined by clock high or clock low (tCH, tCL).
 tQHS accounts for:
 1) The pulse duration distortion of on-chip clock circuits; and
 2) The worst case push-out of DQS on one transition followed by the worst case pull-in of DQ on the next transition, both of which are, separately, due to data pin skew and output pattern effects, and p-channel to n-channel variation of the output drivers.
22. tDQSQ: Consists of data pin skew and output pattern effects, and p-channel to n-channel variation of the output drivers as well as output slew rate mismatch between DQS / \overline{DQS} and associated DQ in any given cycle.
23. tDAL = (nWR) + (tRP/tCK) :
 For each of the terms above, if not already an integer, round to the next highest integer. tCK refers to the application clock period. nWR refers to the tWR parameter stored in the MRS.
 Example: For gDDR533 at t CK = 3.75 ns with tWR programmed to 4 clocks. tDAL = 4 + (15 ns / 3.75 ns) clocks = 4 +(4)clocks=8clocks.
24. The clock frequency is allowed to change during self-refresh mode or precharge power-down mode. In case of clock frequency change during pre-charge power-down, a specific procedure is required as described in gDDR2 device operation
25. ODT turn on time min is when the device leaves high impedance and ODT resistance begins to turn on.
 ODT turn on time max is when the ODT resistance is fully on. Both are measured from tAOND.
26. ODT turn off time min is when the device starts to turn off ODT resistance.
 ODT turn off time max is when the bus is in high impedance. Both are measured from tAOFD.
27. tHZ and tLZ transitions occur in the same access time as valid data transitions. These parameters are referenced to a specific voltage level which specifies when the device output is no longer driving (tHZ), or begins driving (tLZ) . Following figure shows a method to calculate the point when device is no longer driving (tHZ), or begins driving (tLZ) by measuring the signal at two different voltages. The actual voltage measurement points are not critical as long as the calculation is consistent.
28. tRPST end point and tRPRE begin point are not referenced to a specific voltage level but specify when the device output is no longer driving (tRPST), or begins driving (tRPRE). Following figure shows a method to calculate these points when the device is no longer driving (tRPST), or begins driving (tRPRE) by measuring the signal at two different voltages. The actual voltage measurement points are not critical as long as the calculation is consistent. These notes are referenced to the "Timing parameters by speed grade" tables for gDDR2-550/600/700 and gDDR2-800.

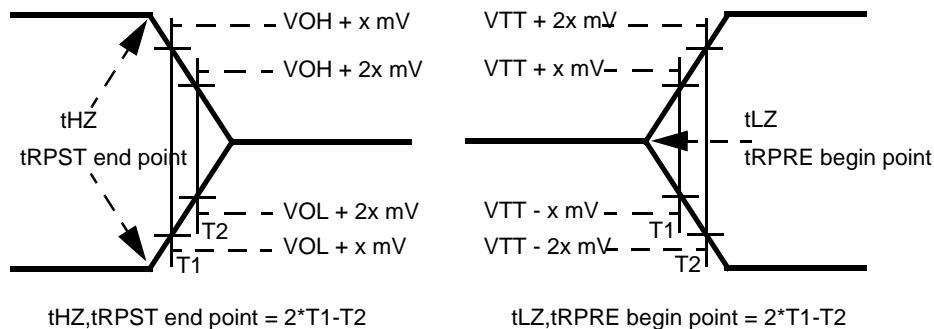

<Test method for tLZ, tHZ, tRPRE and tRPST>

- 29. Input waveform timing with differential data strobe enabled MR[bit10]=0, is referenced from the input signal crossing at the $V_{IH(ac)}$ level to the differential data strobe crosspoint for a rising signal, and from the input signal crossing at the $V_{IL(ac)}$ level to the differential data strobe crosspoint for a falling signal applied to the device under test.
- 30. Input waveform timing with differential data strobe enabled MR[bit10]=0, is referenced from the input signal crossing at the $V_{IH(dc)}$ level to the differential data strobe crosspoint for a rising signal and $V_{IL(dc)}$ to the differential data strobe crosspoint for a falling signal applied to the device under test.

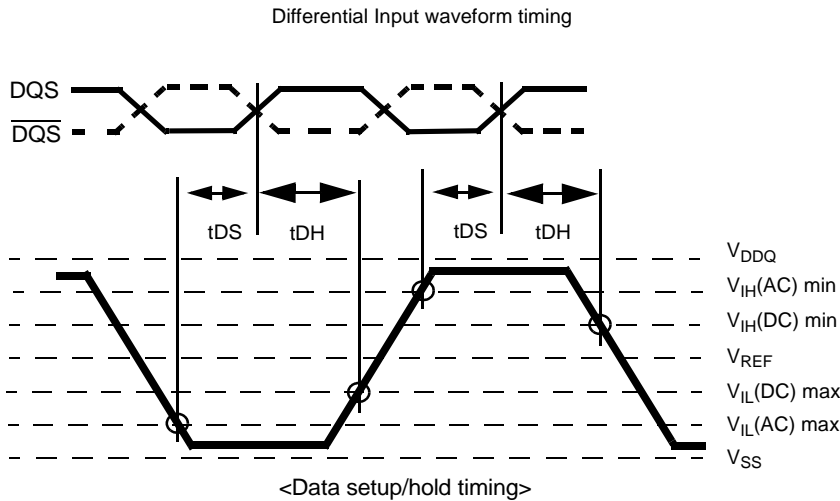

- 31. Input waveform timing is referenced from the input signal crossing at the $V_{IH(ac)}$ level for a rising signal and $V_{IL(ac)}$ for a falling signal applied to the device under test.
- 32. Input waveform timing is referenced from the input signal crossing at the $V_{IL(dc)}$ level for a rising signal and $V_{IH(dc)}$ for a falling signal applied to the device under test.

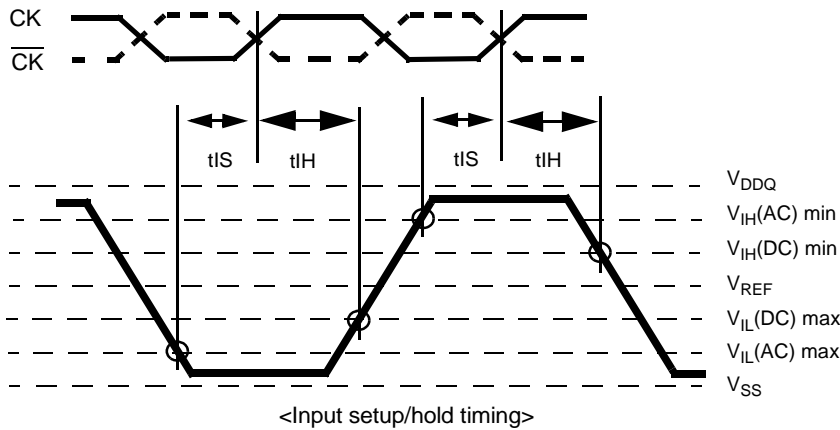

- 33. tWTR is at least two clocks ($2 * tCK$) independent of operation frequency.
- 34. Input waveform timing with single-ended data strobe enabled MR[bit10] = 1, is referenced from the input signal crossing at the $V_{IH(ac)}$ level to the single-ended data strobe crossing $V_{IH/L(dc)}$ at the start of its transition for a rising signal, and from the input signal crossing at the $V_{IL(ac)}$ level to the single-ended data strobe crossing $V_{IH/L(dc)}$ at the start of its transition for a falling signal applied to the device under test. The DQS signal must be monotonic between $V_{il(dc)max}$ and $V_{ih(dc)min}$.
- 35. Input waveform timing with single-ended data strobe enabled MR[bit10] = 1, is referenced from the input signal crossing at the $V_{IH(dc)}$ level to the single-ended data strobe crossing $V_{IH/L(ac)}$ at the end of its transition for a rising signal, and from the input signal crossing at the $V_{IL(dc)}$ level to the single-ended data strobe crossing $V_{IH/L(ac)}$ at the end of its transition for a falling signal applied to the device under test. The DQS signal must be monotonic between $V_{il(dc)max}$ and $V_{ih(dc)min}$.
- 36. tCKEmin of 3 clocks means CKE must be registered on three consecutive positive clock edges. CKE must remain at the valid input level the entire time it takes to achieve the 3 clocks of registration. Thus, after any cKE transition, CKE may not transition from its valid level during the time period of $tIS + 2*tCK + tIH$.

Device Operation & Timing Diagram

Functional Description

Simplified State Diagram

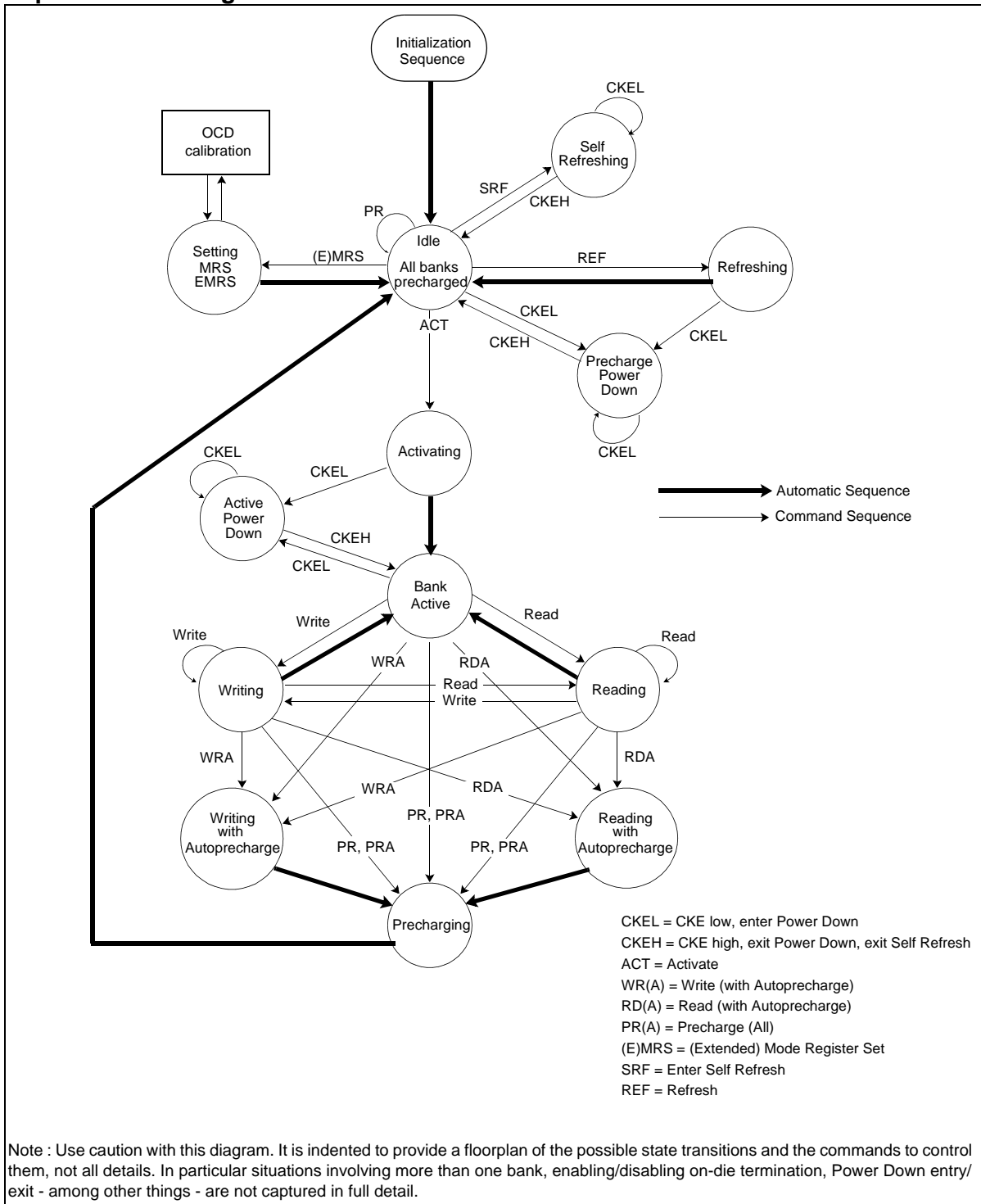

Basic Functionality

Read and write accesses to the gDDR2 SDRAM are burst oriented; accesses start at a selected location and continue for a burst length of four or eight in a programmed sequence. Accesses begin with the registration of an Active command, which is then followed by a Read or Write command. The address bits registered coincident with the active command are used to select the bank and row to be accessed (BA0, BA1 select the bank; A0-A12 select the row). The address bits registered coincident with the Read or Write command are used to select the starting column location for the burst access and to determine if the auto precharge command is to be issued. Prior to normal operation, the gDDR2 SDRAM must be initialized. The following sections provide detailed information covering device initialization, register definition, command descriptions and device operation.

Power up and Initialization

gDDR2 SDRAMs must be powered up and initialized in a predefined manner. Operational procedures other than those specified may result in undefined operation.

Power-up and Initialization Sequence

The following sequence is required for POWER UP and Initialization.

1. Apply power and attempt to maintain CKE below $0.2 \cdot V_{DDQ}$ and ODT^{*1} at a low state (all other inputs may be undefined.) The power voltage ramps are without any slope reversal, ramp time must be no greater than 20mS; and during the ramp, $V_{DD} > V_{DDL} > V_{DDQ}$ and $V_{DD} - V_{DDQ} < 0.3$ volts.

- V_{DD}^{*2} , V_{DDL}^{*2} and V_{DDQ} are driven from a single power converter output, AND
- V_{TT} is limited to 0.95 V max, AND
- V_{ref} tracks $V_{DDQ}/2$.

or

- Apply V_{DD}^{*2} before or at the same time as V_{DDL} .
- Apply V_{DDL}^{*2} before or at the same time as V_{DDQ} .
- Apply V_{DDQ} before or at the same time as V_{TT} & V_{REF} .

at least one of these two sets of conditions must be met.

2. Start clock and maintain stable condition.
3. For the minimum of 200 μ s after stable power and clock (CK, \overline{CK}), then apply NOP or deselect & take CKE high.
4. Wait minimum of 400ns then issue precharge all command. NOP or deselect applied during 400ns period.
5. Issue EMRS(2) command. (To issue EMRS(2) command, provide "Low" to BA0, "High" to BA1.)
6. Issue EMRS(3) command. (To issue EMRS(3) command, provide "High" to BA0 and BA1.)
7. Issue EMRS to enable DLL. (To issue "DLL Enable" command, provide "Low" to A0, "High" to BA0 and "Low" to BA1 and A12.)
8. Issue a Mode Register Set command for "DLL reset"^{*2}.
(To issue DLL reset command, provide "High" to A8 and "Low" to BA0-1)
9. Issue precharge all command.
10. Issue 2 or more auto-refresh commands.
11. Issue a mode register set command with low to A8 to initialize device operation. (i.e. to program operating parameters without resetting the DLL.
12. At least 200 clocks after step 8, execute OCD Calibration (Off Chip Driver impedance adjustment).
If OCD calibration is not used, EMRS OCD Default command (A9=A8=A7=1) followed by EMRS OCD Calibration Mode Exit command (A9=A8=A7=0) must be issued with other operating parameters of EMRS.
13. The gDDR2 SDRAM is now ready for normal operation.

*1) To guarantee ODT off, V_{REF} must be valid and a low level must be applied to the ODT pin.

*2) If DC voltage level of V_{DDL} or V_{DD} is intentionally changed during normal operation, (for example, for the purpose of V_{DD} corner test, or power saving) "DLL Reset" must be executed.

Initialization Sequence after Power Up

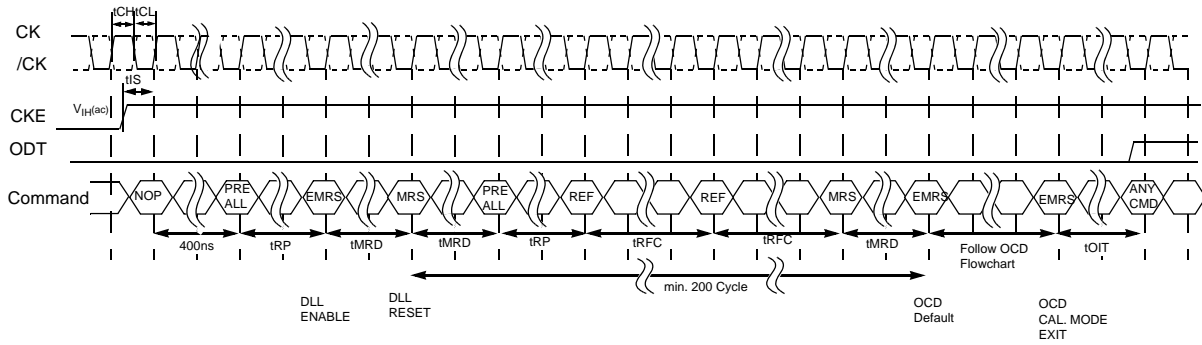

Programming the Mode Register

For application flexibility, burst length, burst type, CAS latency, DLL reset function, write recovery time (tWR) are user defined variables and must be programmed with a Mode Register Set (MRS) command. Additionally, DLL disable function, driver impedance, additive CAS latency, ODT (On Die Termination), single-ended strobe, and OCD (off chip driver impedance adjustment) are also user defined variables and must be programmed with an Extended Mode Register Set (EMRS) command. Contents of the Mode Register (MR) or Extended Mode Registers (EMR(#)) can be altered by re-executing the MRS and EMRS Commands. If the user chooses to modify only a subset of the MRS or EMRS variables, all variables must be redefined when the MRS or EMRS commands are issued. MRS, EMRS and Reset DLL do not affect array contents, which means reinitialization including those can be executed any time after power-up without affecting array contents.

gDDR2 SDRAM Mode Register Set (MRS)

The mode register stores the data for controlling the various operating modes of gDDR2 SDRAM. It controls CAS latency, burst length, burst sequence, test mode, DLL reset, tWR and various vendor specific options to make gDDR2 SDRAM useful for various applications. The default value of the mode register is not defined, therefore the mode register must be written after power-up for proper operation. The mode register is written by asserting low on CS, RAS, CAS, WE, BA0 and BA1, while controlling the state of address pins A0 ~ A15. The gDDR2 SDRAM should be in all bank precharge with CKE already high prior to writing into the mode register. The mode register set command cycle time (tMRD) is required to complete the write operation to the mode register. The mode register contents can be changed using the same command and clock cycle requirements during normal operation as long as all banks are in the precharge state. The mode register is divided into various fields depending on functionality. Burst length is defined by A0 ~ A2 with options of 4 and 8 bit burst lengths. The burst length decodes are compatible with gDDR SDRAM. Burst address sequence type is defined by A3, CAS latency is defined by A4 ~ A6. The gDDR2 doesn't support half clock latency mode. A7 is used for test mode. A8 is used for DLL reset. A7 must be set to low for normal MRS operation. Write recovery time tWR is defined by A9 ~ A11. Refer to the table for specific codes.

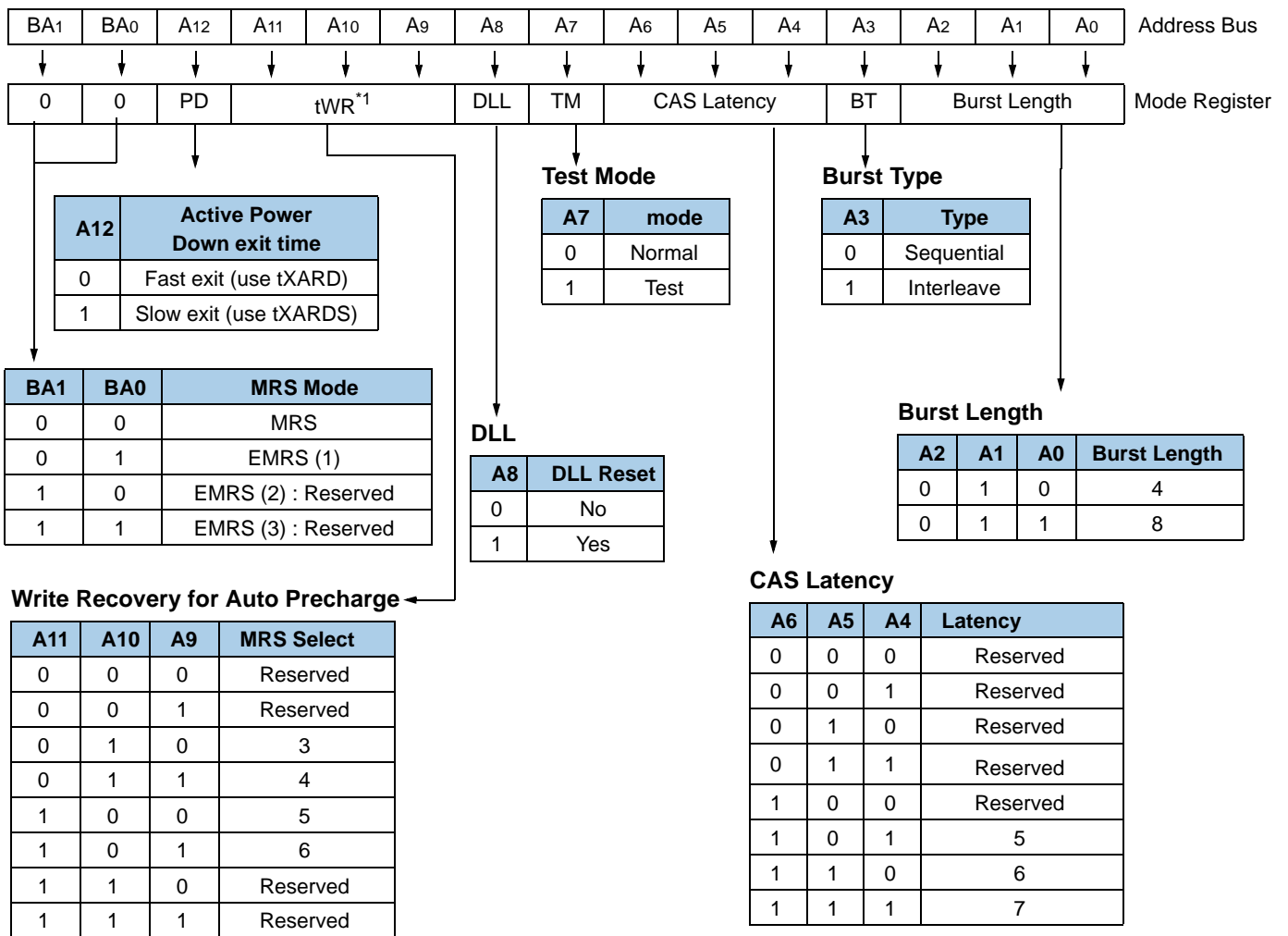

*1 : WR(write recovery for autoprecharge) min should be set with the value which is settled by speed bin.

gDDR2 SDRAM Extended Mode Register Set**EMRS(1)**

The extended mode register(1) stores the data for enabling or disabling the DLL, output driver strength, ODT value selection and additive latency. The default value of the extended mode register is not defined, therefore the extended mode register must be written after power-up for proper operation. The extended mode register is written by asserting low on \overline{CS} , \overline{RAS} , \overline{CAS} , \overline{WE} and high on BA0, while controlling the states of address pins A0 ~ A12. The gDDR2 SDRAM should be in all bank precharge with CKE already high prior to writing into the extended mode register. The mode register set command cycle time (tMRD) must be satisfied to complete the write operation to the extended mode register. Mode register contents can be changed using the same command and clock cycle requirements during normal operation as long as all banks are in the precharge state. A0 is used for DLL enable or disable. A1 is used for enabling a half strength data-output driver. A3~A5 determines the additive latency, A2 and A6 are used for ODT value selection, A7~A9 are used for OCD control, A10 is used for DQS# disable.

DLL Enable/Disable

The DLL must be enabled for normal operation. DLL enable is required during power up initialization, and upon returning to normal operation after having the DLL disabled. The DLL is automatically disabled when entering self refresh operation and is automatically re-enabled upon exit of self refresh operation. Any time the DLL is enabled (and subsequently reset), 200 clock cycles must occur before a Read command can be issued to allow time for the internal clock to be synchronized with the external clock. Failing to wait for synchronization to occur may result in a violation of the tAC or tDQCK parameters.

EMRS(2)

The extended mode register(2) controls refresh related features. The default value of the extended mode register(2) is not defined, therefore the extended mode register(2) must be written after power-up for proper operation. The extended mode register(2) is written by asserting low on \overline{CS} , \overline{RAS} , \overline{CAS} , \overline{WE} , high on BA1 and low on BA0, while controlling the states of address pins A0 ~ A15. The gDDR2 SDRAM should be in all bank precharge with CKE already high prior to writing into the extended mode register(2). The mode register set command cycle time (tMRD) must be satisfied to complete the write operation to the extended mode register(2). Mode register contents can be changed using the same command and clock cycle requirements during normal operation as long as all banks are in the precharge state.

EMRS (1) Programming

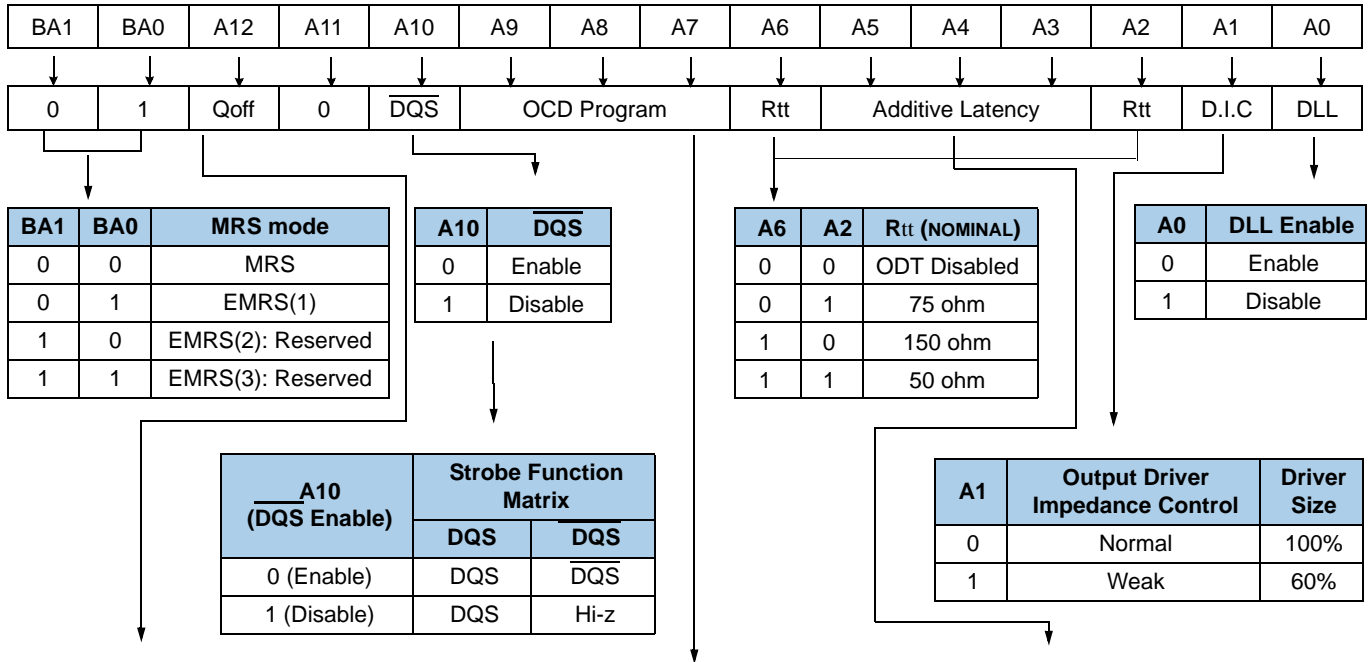

BA1	BA0	MRS mode
0	0	MRS
0	1	EMRS(1)
1	0	EMRS(2): Reserved
1	1	EMRS(3): Reserved

A10	\overline{DQS}
0	Enable
1	Disable

A6	A2	Rtt (NOMINAL)
0	0	ODT Disabled
0	1	75 ohm
1	0	150 ohm
1	1	50 ohm

A0	DLL Enable
0	Enable
1	Disable

$\overline{A10}$ (DQS Enable)	Strobe Function Matrix	
	DQS	\overline{DQS}
0 (Enable)	DQS	\overline{DQS}
1 (Disable)	DQS	Hi-z

A1	Output Driver Impedance Control	Driver Size
0	Normal	100%
1	Weak	60%

A12	Qoff (Optional) ^a
0	Output buffer enabled
1	Output buffer disabled

a. Outputs disabled - DQs, DQSs, \overline{DQS} s . This feature is used in conjunction with dimm IDD measurements when IDDQ is not desired to be included.

A9	A8	A7	OCD Calibration Program
0	0	0	OCD Calibration mode exit; maintain setting
0	0	1	Drive(1)
0	1	0	Drive(0)
1	0	0	Adjust mode ^a
1	1	1	OCD Calibration default ^b

a: When Adjust mode is issued, AL from previously set value must be applied.

b: After setting to default, OCD mode needs to be exited by setting A9-A7 to 000. Refer to the following 3.2.2.3 section for detailed information.

A5	A4	A3	Additive Latency
0	0	0	0
0	0	1	1
0	1	0	2
0	1	1	3
1	0	0	4
1	0	1	5
1	1	0	Reserved
1	1	1	Reserved

EMRS (2) Programming

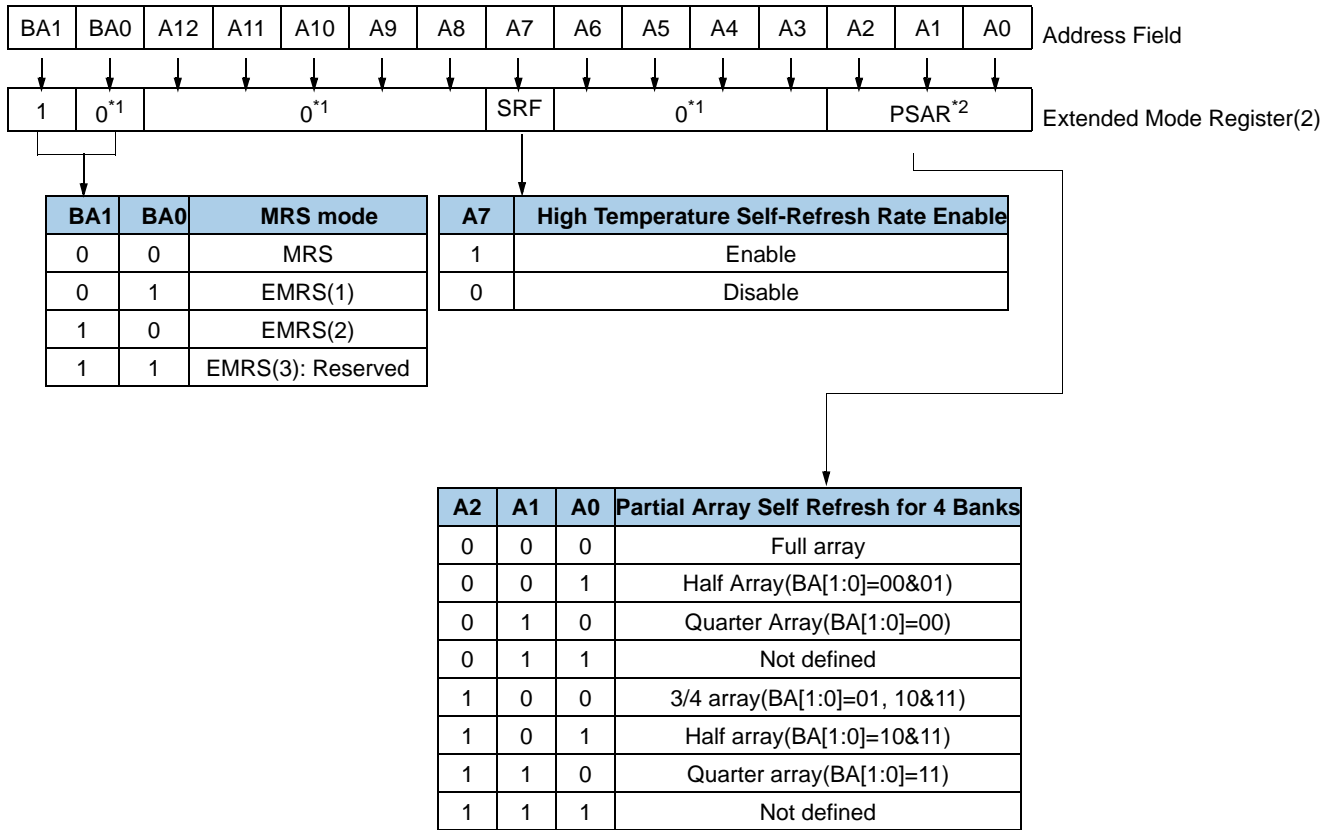

*1 : The rest bits in EMRS(2) is reserved for future use and all bits except A0, A1, A2, A7 and BA0, BA1, must be programmed to 0 when setting the mode register during initialization.

*2 : If PASR (Partial Array Self Refresh) is enabled, data located in areas of the array beyond the specified location will be lost if self refresh is entered. Data integrity will be maintained if tREF conditions are met and no Self Refresh command is issued. PASR is supported from the device of 90nm technology(512Mb C-die).

EMRS (3) Programming : Reserved*1

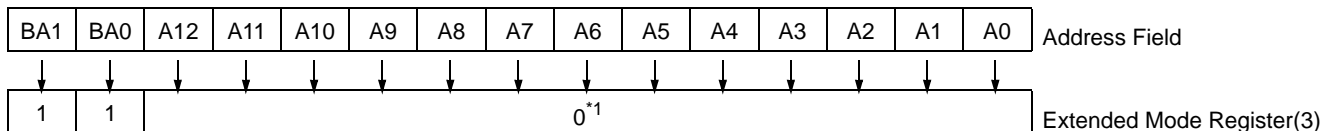

*1 : All bits in EMRS(3) except BA0 and BA1 are reserved for future use and must be programmed to 0 when setting the mode register during initialization.

Off-Chip Driver (OCD) Impedance Adjustment

gDDR2 SDRAM supports driver calibration feature and the flow chart below is an example of sequence. Every calibration mode command should be followed by "OCD calibration mode exit" before any other command being issued. MRS should be set before entering OCD impedance adjustment and ODT (On Die Termination) should be carefully controlled depending on system environment.

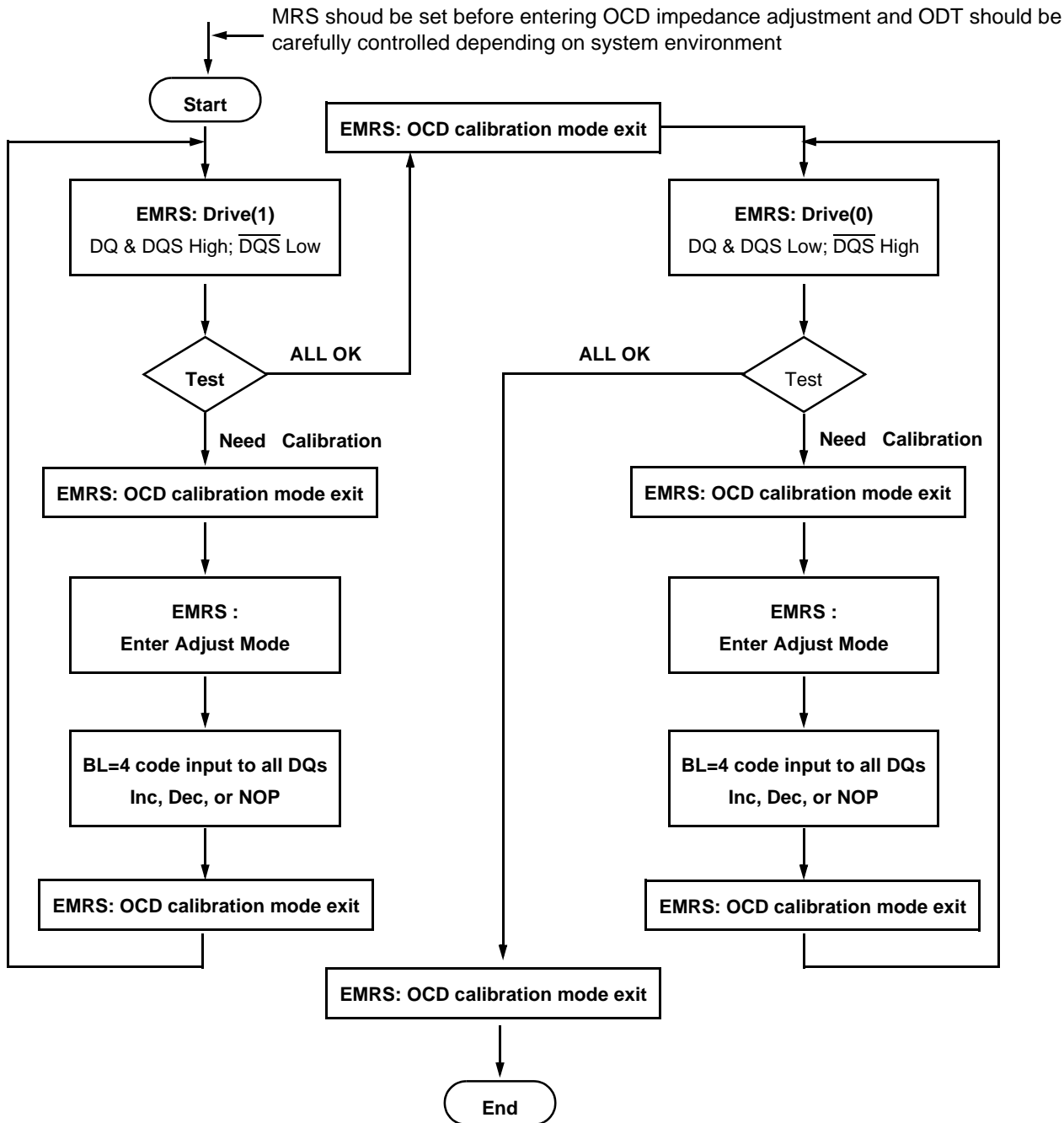

Extended Mode Register Set for OCD impedance adjustment

OCD impedance adjustment can be done using the following EMRS mode. In drive mode all outputs are driven out by gDDR2 SDRAM and drive of DQS is dependent on EMRS bit enabling DQS operation. In Drive(1) mode, all DQ, DQS signals are driven high and all \overline{DQS} signals are driven low. In drive(0) mode, all DQ, DQS signals are driven low and all \overline{DQS} signals are driven high. In adjust mode, BL = 4 of operation code data must be used. In case of OCD calibration default, output driver characteristics have a nominal impedance value of 18 ohms during nominal temperature and voltage conditions. Output driver characteristics for OCD calibration default are specified in section 6. OCD applies only to normal full strength output drive setting defined by EMRS(1) and if half strength is set, OCD default output driver characteristics are not applicable. When OCD calibration adjust mode is used, OCD default output driver characteristics are not applicable. After OCD calibration is completed or driver strength is set to default, subsequent EMRS commands not intended to adjust OCD characteristics must specify A9-A7 as '000' in order to maintain the default or calibrated value.

Off- Chip-Driver program

A9	A8	A7	Operation
0	0	0	OCD calibration mode exit
0	0	1	Drive(1) DQ, DQS high and \overline{DQS} low
0	1	0	Drive(0) DQ, DQS low and \overline{DQS} high
1	0	0	Adjust mode
1	1	1	OCD calibration default

OCD impedance adjust

To adjust output driver impedance, controllers must issue the ADJUST EMRS command along with a 4bit burst code to gDDR2 SDRAM as in the following table. For this operation, Burst Length has to be set to BL = 4 via MRS command before activating OCD and controllers must drive this burst code to all DQs at the same time. DT0 in the following table means all DQ bits at bit time 0, DT1 at bit time 1, and so forth. The driver output impedance is adjusted for all gDDR2 SDRAM DQs simultaneously and after OCD calibration, all DQs of a given gDDR2 SDRAM will be adjusted to the same driver strength setting. The maximum step count for adjustment is 16 and when the limit is reached, further increment or decrement code has no effect. The default setting may be any step within the 16 step range. When Adjust mode command is issued, AL from previously set value must be applied.

Off- Chip-Driver program

4bit burst code inputs to all DQs				Operation	
D _{T0}	D _{T1}	D _{T2}	D _{T3}	Pull-up driver strength	Pull-down driver strength
0	0	0	0	NOP (No operation)	NOP (No operation)
0	0	0	1	Increase by 1 step	NOP
0	0	1	0	Decrease by 1 step	NOP
0	1	0	0	NOP	Increase by 1 step
1	0	0	0	NOP	Decrease by 1 step
0	1	0	1	Increase by 1 step	Increase by 1 step
0	1	1	0	Decrease by 1 step	Increase by 1 step
1	0	0	1	Increase by 1 step	Decrease by 1 step
1	0	1	0	Decrease by 1 step	Decrease by 1 step
Other Combinations				Reserved	

For proper operation of adjust mode, WL = RL - 1 = AL + CL - 1 clocks and tDS/tDH should be met as the following timing diagram. For input data pattern for adjustment, DT0 - DT3 is a fixed order and "not affected by MRS addressing mode (ie. sequential or interleaved).

ODT (On Die Termination)

On Die Termination (ODT) is a feature that allows a DRAM to turn on/off termination resistance. For x16 configuration ODT is applied to each DQ, UDQS/UDQS, LDQS/LDQS, UDM, and LDM signal via the ODT control pin. The ODT feature is designed to improve signal integrity of the memory channel by allowing the DRAM controller to independently turn on/off termination resistance for any or all DRAM devices. The ODT function is supported for ACTIVE and STANDBY modes, and turned off and not supported in SELF REFRESH mode.

Functional Representation of ODT

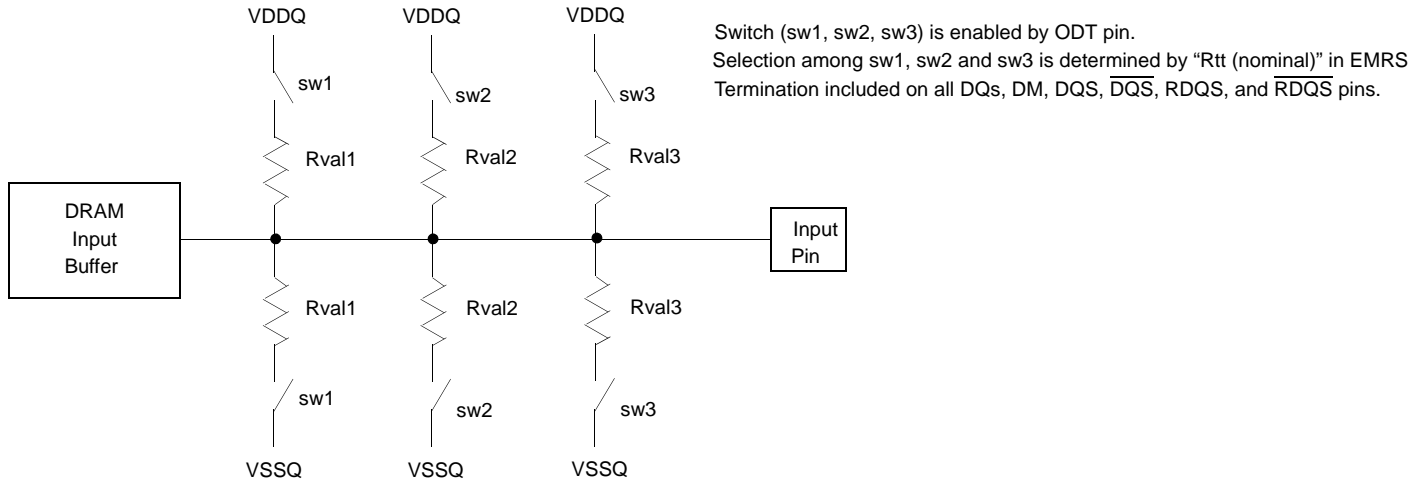

ODT DC Electrical Characteristics

Parameter/Condition	Symbol	Min	Nom	Max	Units	Notes
Rtt effective impedance value for EMRS(A6,A2)=0,1; 75 ohm	Rtt1(eff)	60	75	90	ohm	1
Rtt effective impedance value for EMRS(A6,A2)=1,0; 150 ohm	Rtt2(eff)	120	150	180	ohm	1
Rtt mismatch tolerance between any pull-up/pull-down pair	Rtt(mis)	-3.75		+3.75	%	1

Note 1: Test condition for Rtt measurements

Measurement Definition for Rtt(eff): Apply V_{IH} (AC) and V_{IL} (AC) to test pin separately, then measure current I(V_{IH} (AC)) and I(V_{IL} (AC)) respectively. V_{IH} (AC), V_{IL} (AC), and VDDQ values defined in SSTL_18

$$R_{tt}(eff) = \frac{V_{IH}(AC) - V_{IL}(AC)}{I(V_{IH}(AC)) - I(V_{IL}(AC))}$$

$$\text{delta VM} = \left(\frac{2 \times V_m}{V_{DDQ}} - 1 \right) \times 100\%$$

Measurement Definition for VM : Measure voltage (VM) at test pin (midpoint) with no load.

ODT timing for active/standby mode

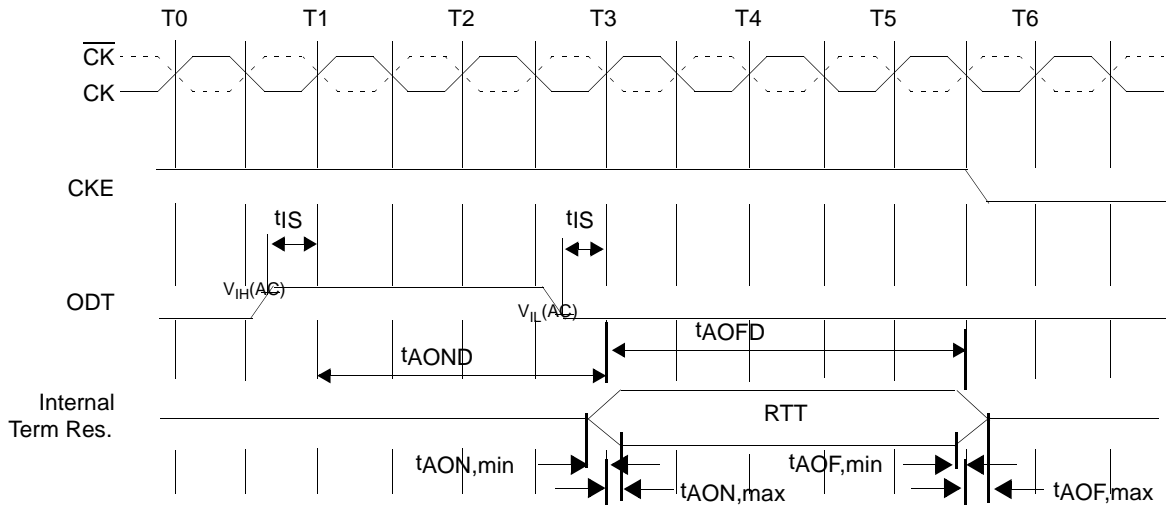

ODT timing for powerdown mode

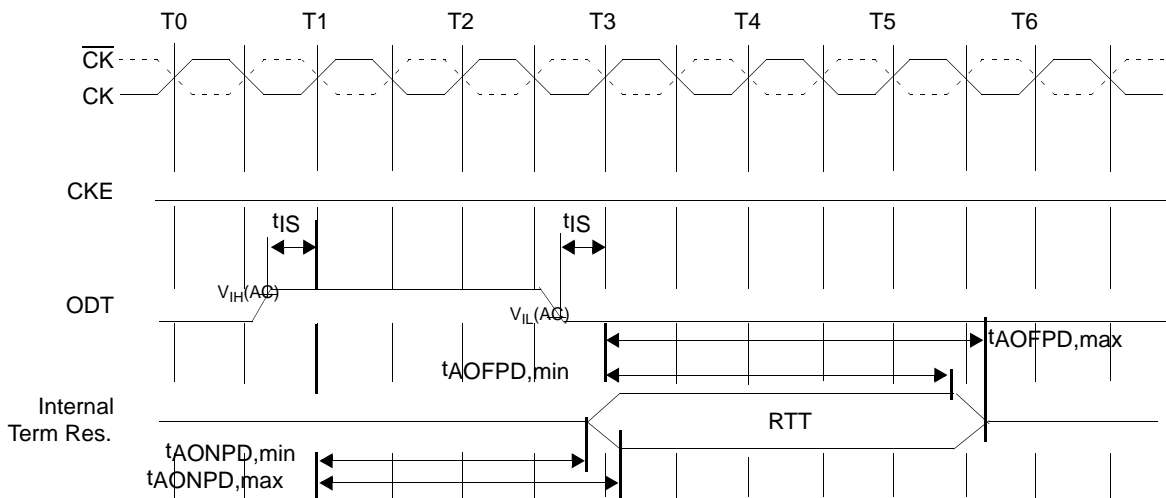

ODT timing mode switch at entering power down mode

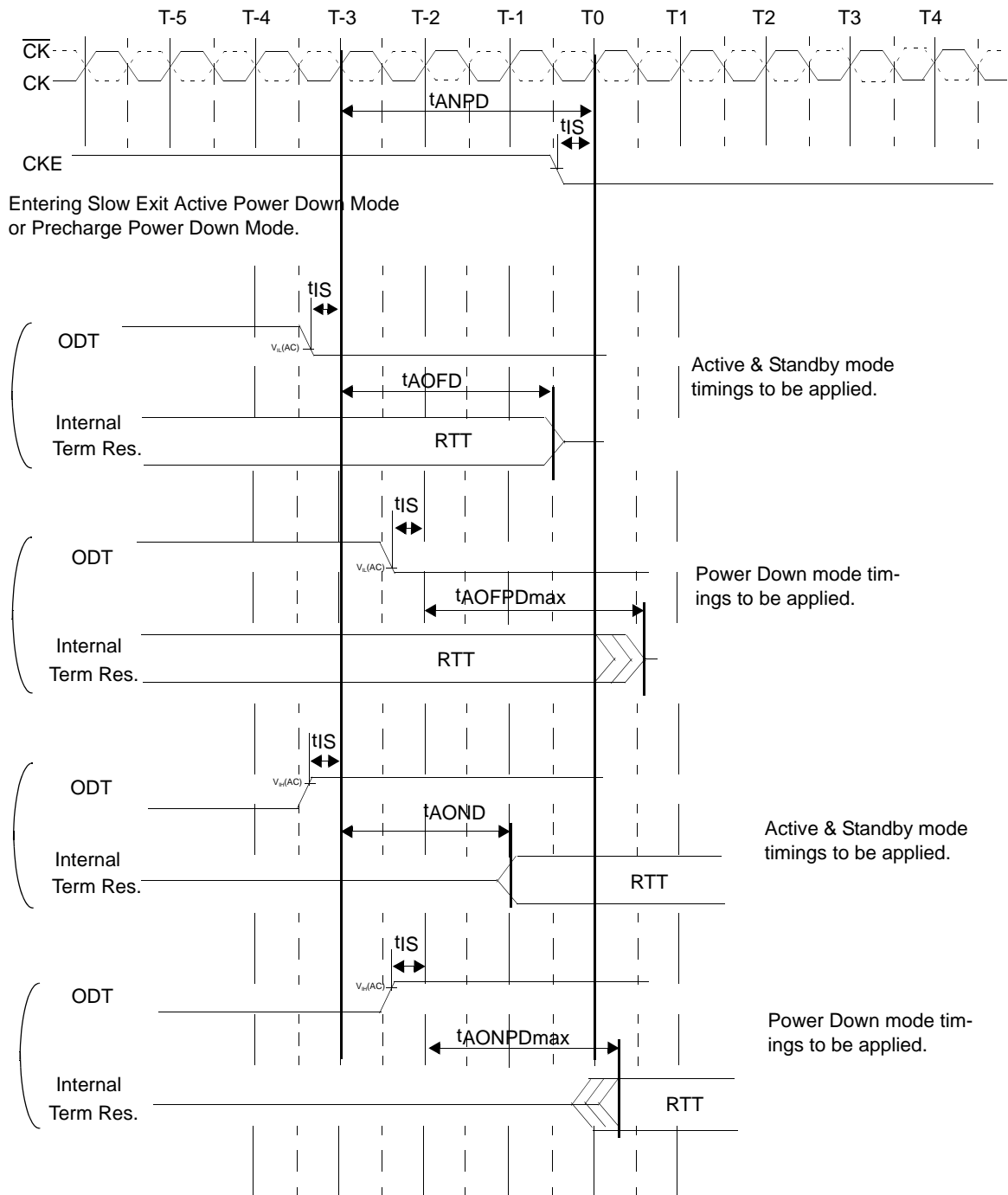

ODT timing mode switch at exiting power down mode

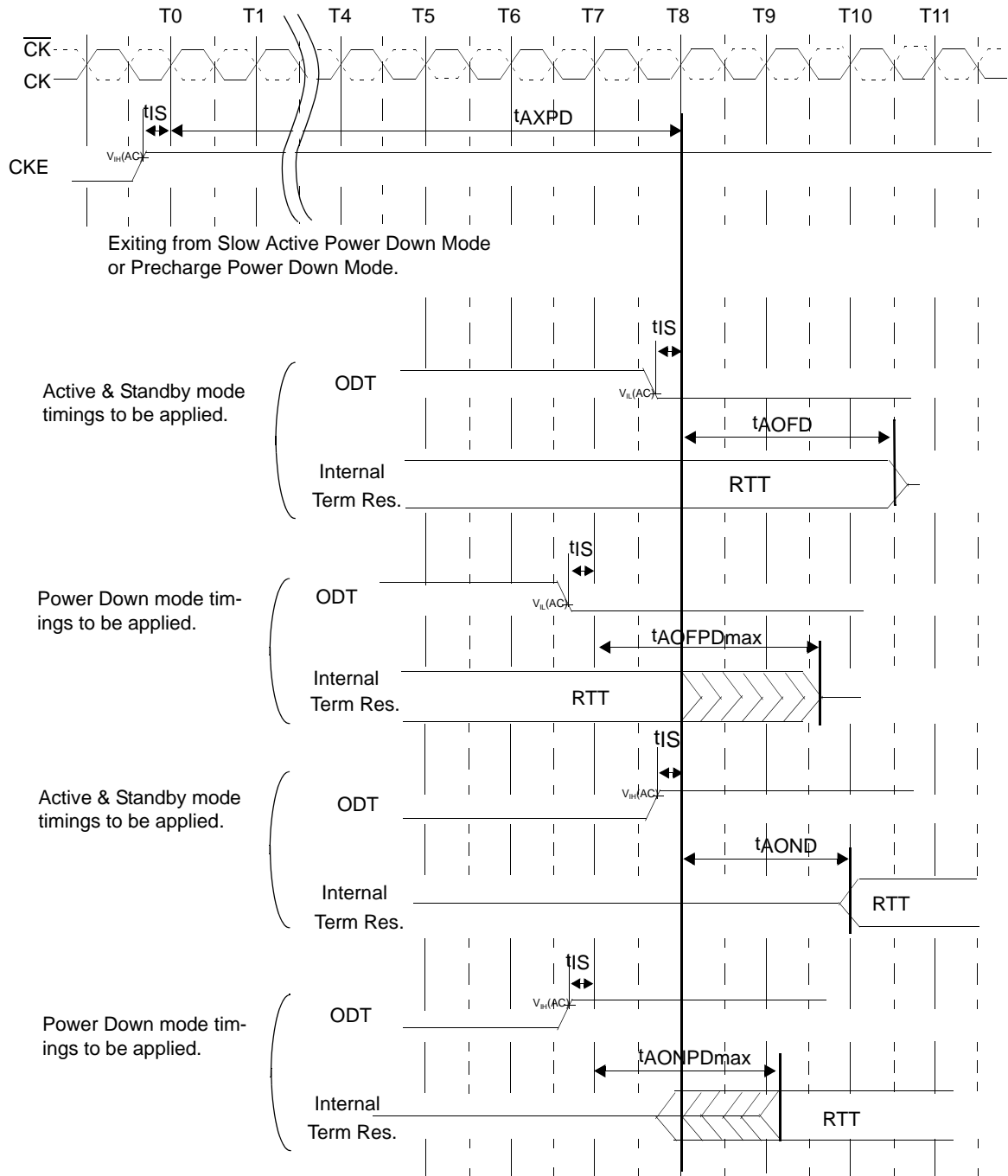

Bank Activate Command

Posted $\overline{\text{CAS}}$ operation is supported to make command and data bus efficient for sustainable bandwidths in gDDR2 SDRAM. In this operation, the gDDR2 SDRAM allows a $\overline{\text{CAS}}$ read or write command to be issued immediately after the RAS bank activate command (or any time during the $\overline{\text{RAS-CAS}}$ -delay time, t_{RCD} , period). The command is held for the time of the Additive Latency (AL) before it is issued inside the device. The Read Latency (RL) is controlled by the sum of AL and the $\overline{\text{CAS}}$ latency (CL). Therefore if a user chooses to issue a R/W command before the t_{RCDmin} , then AL (greater than 0) must be written into the EMR(1). The Write Latency (WL) is always defined as $\text{RL} - 1$ (read latency -1) where read latency is defined as the sum of additive latency plus CAS latency ($\text{RL}=\text{AL}+\text{CL}$). Read or Write operations using AL allow seamless bursts (refer to seamless operation timing diagram examples in Read burst and Write burst section)

Bank Activate Command Cycle: $t_{\text{RCD}} = 3$, $\text{AL} = 2$, $t_{\text{RP}} = 3$, $t_{\text{RRD}} = 2$, $t_{\text{CCD}} = 2$

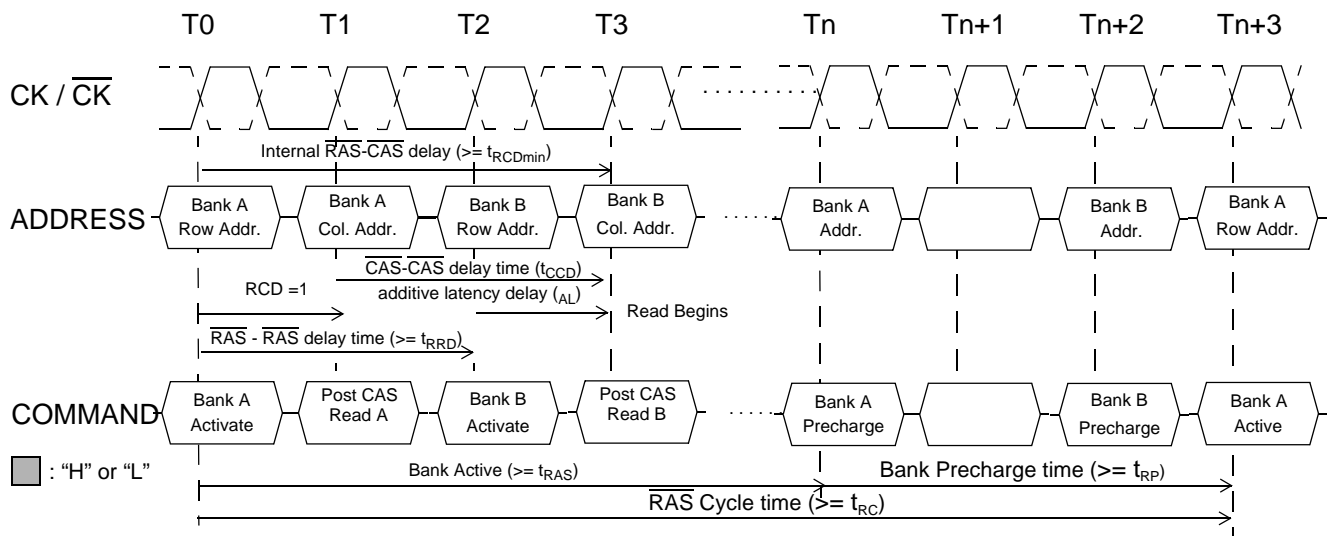

Read and Write Access Modes

After a bank has been activated, a read or write cycle can be executed. This is accomplished by setting $\overline{\text{RAS}}$ high, $\overline{\text{CS}}$ and $\overline{\text{CAS}}$ low at the clock's rising edge. $\overline{\text{WE}}$ must also be defined at this time to determine whether the access cycle is a read operation ($\overline{\text{WE}}$ high) or a write operation ($\overline{\text{WE}}$ low). The DDR2 SDRAM provides a fast column access operation. A single Read or Write Command will initiate a serial read or write operation on successive clock cycles. The boundary of the burst cycle is strictly restricted to specific segments of the page length. For example, the 32Mbit x 4 I/O x 4 Bank chip has a page length of 2048 bits (defined by CA0-CA9, CA11). The page length of 2048 is divided into 512 or 256 uniquely addressable boundary segments depending on burst length, 512 for 4 bit burst, 256 for 8 bit burst respectively. A 4-bit or 8 bit burst operation will occur entirely within one of the 512 or 256 groups beginning with the column address supplied to the device during the Read or Write Command (CA0-CA9, CA11). The second, third and fourth access will also occur within this group segment, however, the burst order is a function of the starting address, and the burst sequence. A new burst access must not interrupt the previous 4 bit burst operation in case of BL = 4 setting. However, in case of BL = 8 setting, two cases of interrupt by a new burst access are allowed, one reads interrupted by a read, the other writes interrupted by a write with 4 bit burst boundary respectively. The minimum CAS to CAS delay is defined by t_{CCD} , and is a minimum of 2 clocks for read or write cycles.

Posted CAS

Burst mode operation is used to provide a constant flow of data to memory locations (write cycle), or from memory locations (read cycle). The parameters that define how the burst mode will operate are burst sequence and burst length. gDDR2 SDRAM supports 4 bit burst and 8 bit burst modes only. For 8 bit burst mode, full interleave address ordering is supported, however, sequential address ordering is nibble based for ease of implementation. The burst type, either sequential or interleaved, is programmable and defined by the address bit 3 (A3) of the MRS, which is similar to the DDR SDRAM operation. Seamless burst read or write operations are supported. Unlike DDR devices, interruption of a burst read or write cycle during BL = 4 mode operation is prohibited. However in case of BL = 8 mode, interruption of a burst read or write operation is limited to two cases, reads interrupted by a read, or writes interrupted by a write. Therefore the Burst Stop command is not supported on gDDR2 SDRAM devices.

Examples of posted CAS operation

Example 1 Read followed by a write to the same bank
 [AL = 2 and CL = 3, RL = (AL + CL) = 5, WL = (RL - 1) = 4]

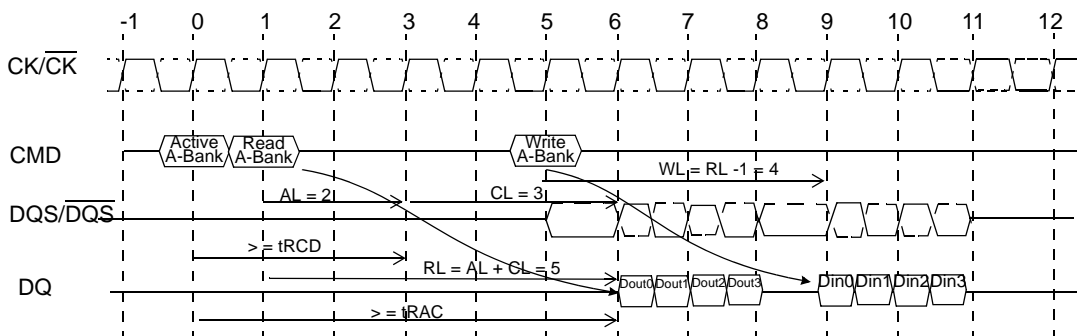

Example 2 Read followed by a write to the same bank
 [AL = 0 and CL = 3, RL = (AL + CL) = 3, WL = (RL - 1) = 2]

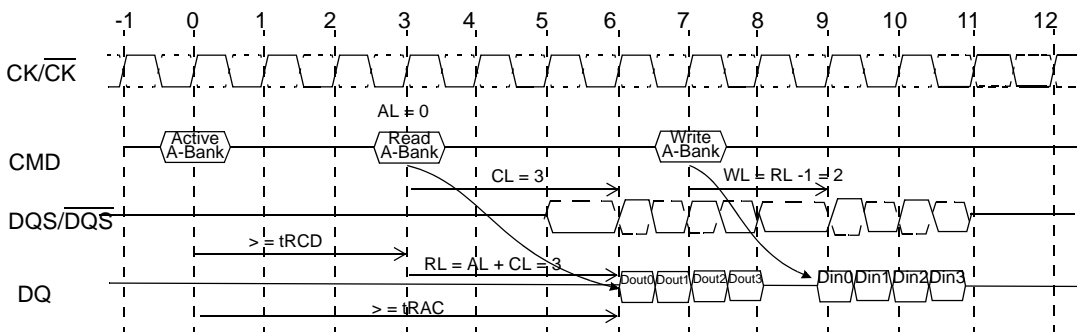

Burst Mode Operation

The Burst Read command is initiated by having \overline{CS} and \overline{CAS} low while holding \overline{RAS} and \overline{WE} high at the rising edge of the clock. The address inputs determine the starting column address for the burst. The delay from the start of the command to when the data from the first cell appears on the outputs is equal to the value of the read latency (RL). The data strobe output (DQS) is driven low 1 clock cycle before valid data (DQ) is driven onto the data bus. The first bit of the burst is synchronized with the rising edge of the data strobe (DQS). Each subsequent data-out appears on the DQ pin in phase with the DQS signal in a source synchronous manner. The RL is equal to an additive latency (AL) plus \overline{CAS} latency (CL). The CL is defined by the Mode Register Set (MRS), similar to the existing SDR and DDR SDRAMs. The AL is defined by the Extended Mode Register Set (1)(EMRS(1)).

gDDR2 SDRAM pin timings are specified for either single ended mode or differential mode depending on the setting of the EMRS "Enable DQS" mode bit; timing advantages of differential mode are realized in system design. The method by which the gDDR2 SDRAM pin timings are measured is mode dependent. In single ended mode, timing relationships are measured relative to the rising or falling edges of DQS crossing at VREF. In differential mode, these timing relationships are measured relative to the crosspoint of DQS and its complement, \overline{DQS} . This distinction in timing methods is guaranteed by design and characterization. Note that when differential data strobe mode is disabled via the EMRS, the complementary pin, \overline{DQS} , must be tied externally to VSS through a 20 ohm to 10 Kohm resistor to insure proper operation.

Burst Length and Sequence

BL = 4

Burst Length	Starting Address (A1 A0)	Sequential Addressing (decimal)	Interleave Addressing (decimal)
4	0 0	0, 1, 2, 3	0, 1, 2, 3
	0 1	1, 2, 3, 0	1, 0, 3, 2
	1 0	2, 3, 0, 1	2, 3, 0, 1
	1 1	3, 0, 1, 2	3, 2, 1, 0

BL = 8

Burst Length	Starting Address (A2 A1 A0)	Sequential Addressing (decimal)	Interleave Addressing (decimal)
8	0 0 0	0, 1, 2, 3, 4, 5, 6, 7	0, 1, 2, 3, 4, 5, 6, 7
	0 0 1	1, 2, 3, 0, 5, 6, 7, 4	1, 0, 3, 2, 5, 4, 7, 6
	0 1 0	2, 3, 0, 1, 6, 7, 4, 5	2, 3, 0, 1, 6, 7, 4, 5
	0 1 1	3, 0, 1, 2, 7, 4, 5, 6	3, 2, 1, 0, 7, 6, 5, 4
	1 0 0	4, 5, 6, 7, 0, 1, 2, 3	4, 5, 6, 7, 0, 1, 2, 3
	1 0 1	5, 6, 7, 4, 1, 2, 3, 0	5, 4, 7, 6, 1, 0, 3, 2
	1 1 0	6, 7, 4, 5, 2, 3, 0, 1	6, 7, 4, 5, 2, 3, 0, 1
	1 1 1	7, 4, 5, 6, 3, 0, 1, 2	7, 6, 5, 4, 3, 2, 1, 0

Note : Page length is a function of I/O organization and column addressin

Burst Read Command

The Burst Write command is initiated by having \overline{CS} , \overline{CAS} and \overline{WE} low while holding \overline{RAS} high at the rising edge of the clock. The address inputs determine the starting column address. Write latency (WL) is defined by a read latency (RL) minus one and is equal to $(AL + CL - 1)$. A data strobe signal (DQS) should be driven low (preamble) one clock prior to the WL. The first data bit of the burst cycle must be applied to the DQ pins at the first rising edge of the DQS following the preamble. The t_{DQSS} specification must be satisfied for write cycles. The subsequent burst bit data are issued on successive edges of the DQS until the burst length is completed, which is 4 or 8 bit burst. When the burst has finished, any additional data supplied to the DQ pins will be ignored. The DQ Signal is ignored after the burst write operation is complete. The time from the completion of the burst write to bank precharge is the write recovery time (WR).

gDDR2 SDRAM pin timings are specified for either single ended mode or differen-tial mode depending on the setting of the EMRS "Enable DQS" mode bit; timing advantages of differential mode are realized in system design. The method by which the gDDR2 SDRAM pin timings are measured is mode dependent. In single ended mode, timing relationships are measured relative to the rising or falling edges of DQS crossing at V_{REF} . In differential mode, these timing relationships are measured relative to the crosspoint of DQS and its complement, \overline{DQS} . This distinction in timing methods is guaranteed by design and characterization. Note that when differential data strobe mode is disabled via the EMRS, the complementary pin, \overline{DQS} , must be tied externally to V_{SS} through a 20 ohm to 10K ohm resistor to insure proper operation.

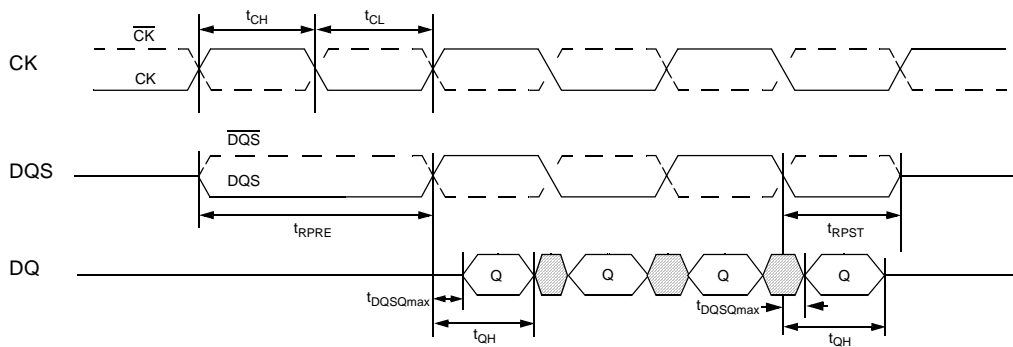

Burst Read Operation: RL = 5 (AL = 2, CL = 3, BL = 4)

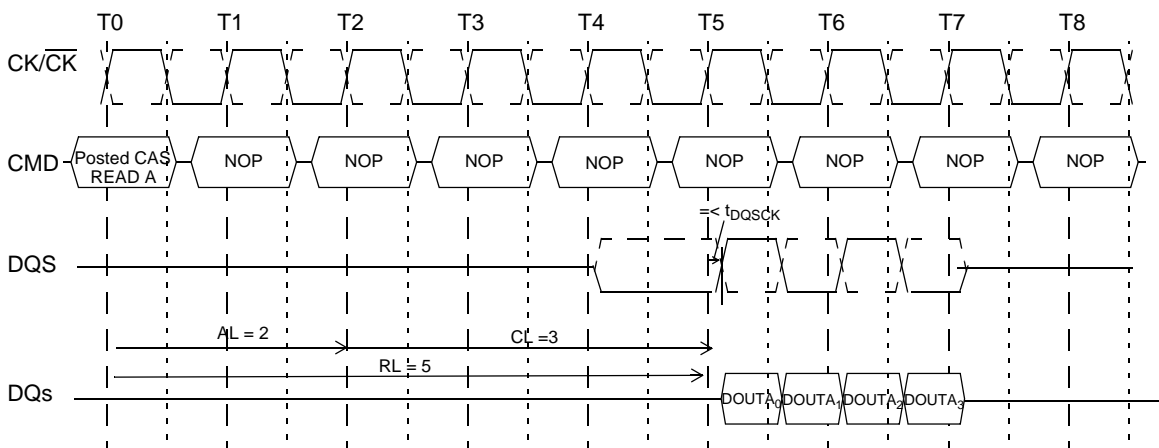

Burst Read Operation: RL = 3 (AL = 0 and CL = 3, BL = 8)

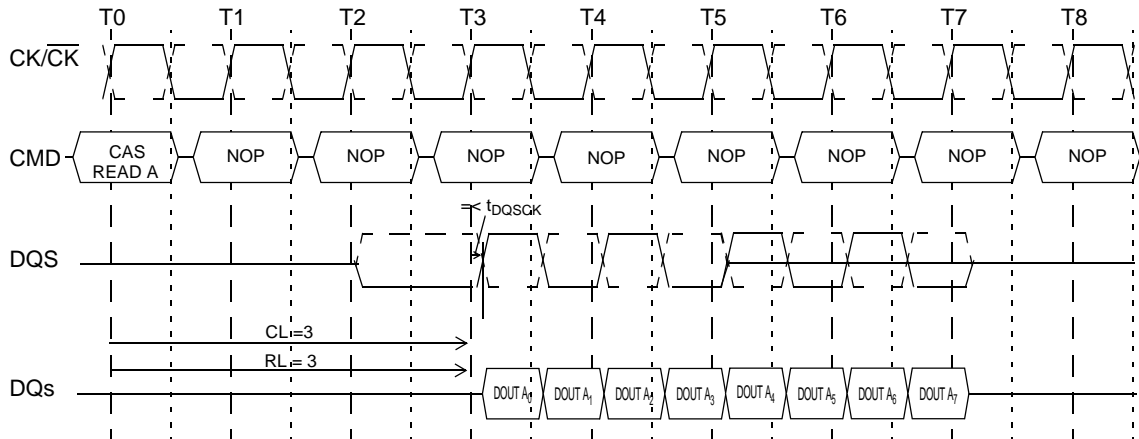

Burst Read followed by Burst Write: RL = 5, WL = (RL-1) = 4, BL = 4

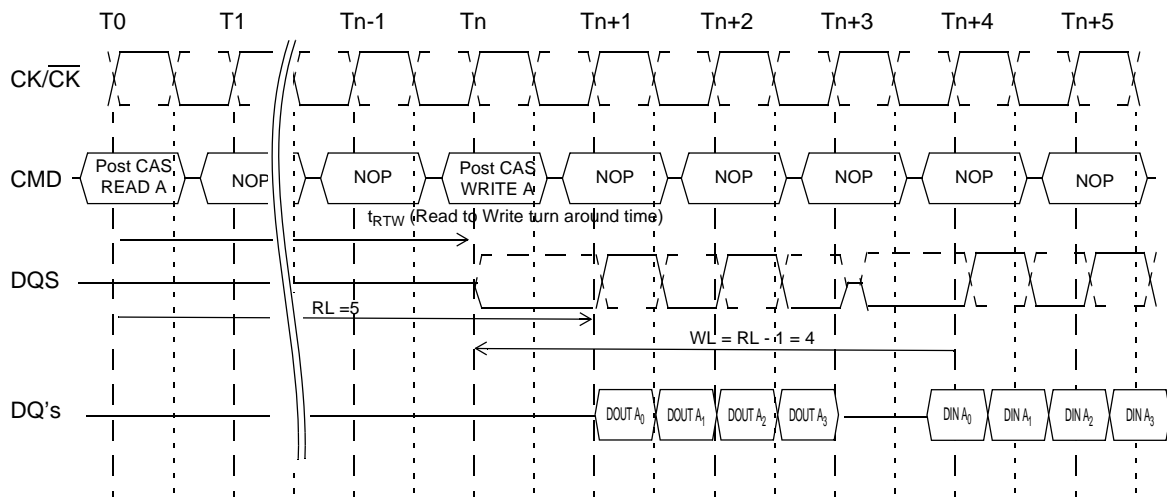

The minimum time from the burst read command to the burst write command is defined by a read-to-write-turn-around-time, which is 4 clocks in case of BL = 4 operation, 6 clocks in case of BL = 8 operation.

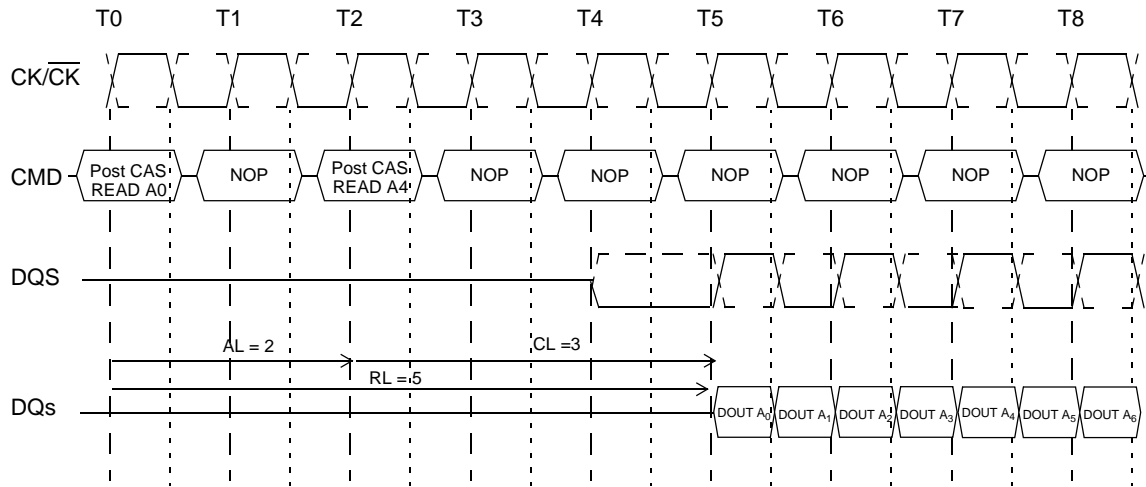

The seamless burst read operation is supported by enabling a read command at every other clock for BL = 4 operation, and every 4 clock for BL = 8 operation. This operation is allowed regardless of same or different banks as long as the banks are activated.

Burst read can only be interrupted by another read with 4 bit burst boundary. Any other case of read interrupt is not allowed.

Read Burst Interrupt Timing Example: (CL=3, AL=0, RL=3, BL=8)

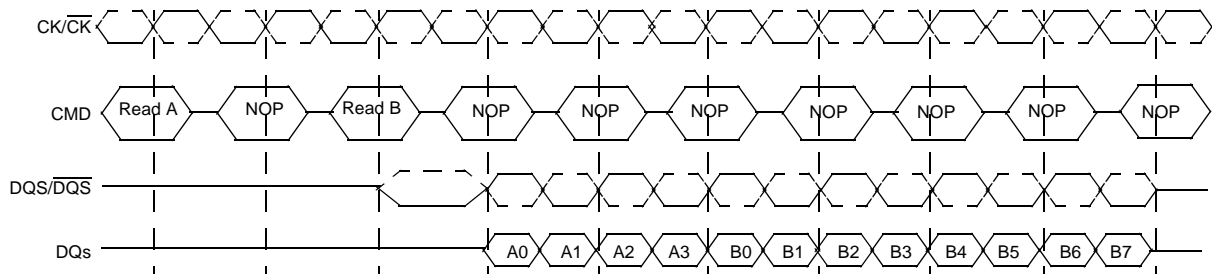

Notes:

1. Read burst interrupt function is only allowed on burst of 8. Burst interrupt of 4 is prohibited.
2. Read burst of 8 can only be interrupted by another Read command. Read burst interruption by Write command or Precharge command is prohibited.
3. Read burst interrupt must occur exactly two clocks after previous Read command. Any other Read burst interrupt timings are prohibited.
4. Read burst interruption is allowed to any bank inside DRAM.
5. Read burst with Auto Precharge enabled is not allowed to interrupt.
6. Read burst interruption is allowed by another Read with Auto Precharge command.
7. All command timings are referenced to burst length set in the mode register. They are not referenced to actual burst. For example, Minimum Read to Precharge timing is $AL + BL/2$ where BL is the burst length set in the mode register and not the actual burst (which is shorter because of interrupt).

Burst Write Operation

The Burst Write command is initiated by having \overline{CS} , \overline{CAS} and \overline{WE} low while holding \overline{RAS} high at the rising edge of the clock. The address inputs determine the starting column address. Write latency (WL) is defined by a read latency (RL) minus one and is equal to $(AL + CL - 1)$; and is the number of clocks of delay that are required from the time the write command is registered to the clock edge associated to the first DQS strobe. A data strobe signal (DQS) should be driven low (preamble) one clock prior to the WL. The first data bit of the burst cycle must be applied to the DQ pins at the first rising edge of the DQS following the preamble. The t_{DQSS} specification must be satisfied for each positive DQS transition to its associated clock edge during write cycles. The subsequent burst bit data are issued on successive edges of the DQS until the burst length is completed, which is 4 or 8 bit burst. When the burst has finished, any additional data supplied to the DQ pins will be ignored. The DQ Signal is ignored after the burst write operation is complete. The time from the completion of the burst write to bank precharge is the write recovery time (WR).

DDR2 SDRAM pin timings are specified for either single ended mode or differential mode depending on the setting of the EMRS "Enable DQS" mode bit; timing advantages of differential mode are realized in system design. The method by which the DDR2 SDRAM pin timings are measured is mode dependent. In single ended mode, timing relationships are measured relative to the rising or falling edges of DQS crossing at the specified AC/DC levels. In differential mode, these timing relationships are measured relative to the crosspoint of DQS and its complement, \overline{DQS} . This distinction in timing methods is guaranteed by design and characterization. Note that when differential data strobe mode is disabled via the EMRS, the complementary pin, \overline{DQS} , must be tied externally to VSS through a 20 ohm to 10K ohm resistor to insure proper operation.

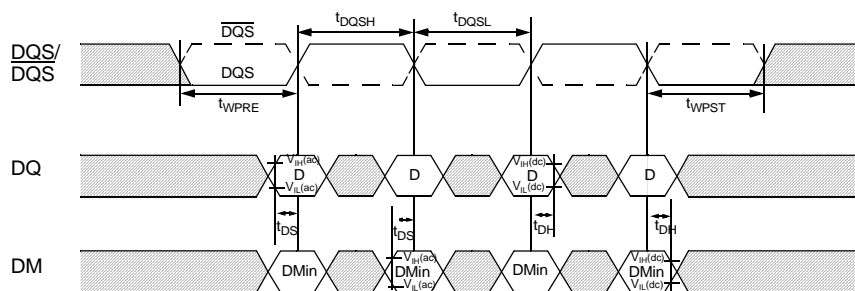

Burst Write Operation: RL = 5, WL = 4, tWR = 3 (AL=2, CL=3), BL = 4

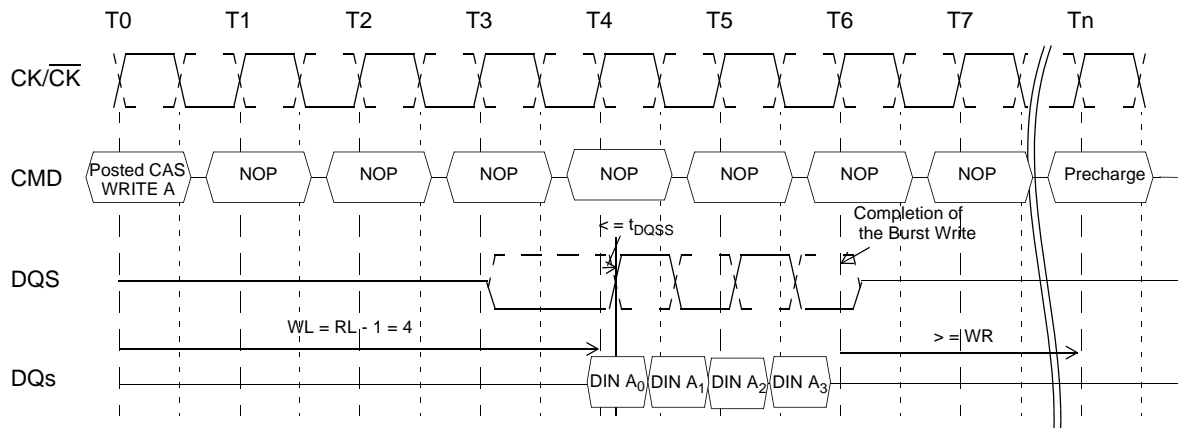

Burst Write Operation: RL = 3, WL = 2, tWR = 2 (AL=0, CL=3), BL = 4

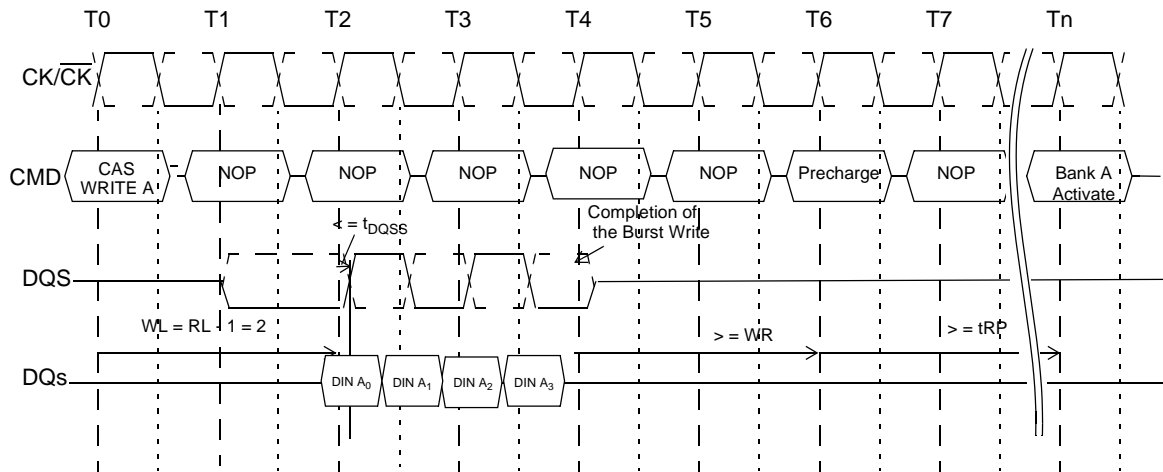

Burst Write followed by Burst Read: RL = 5 (AL=2, CL=3), WL = 4, tWTR = 2, BL = 4

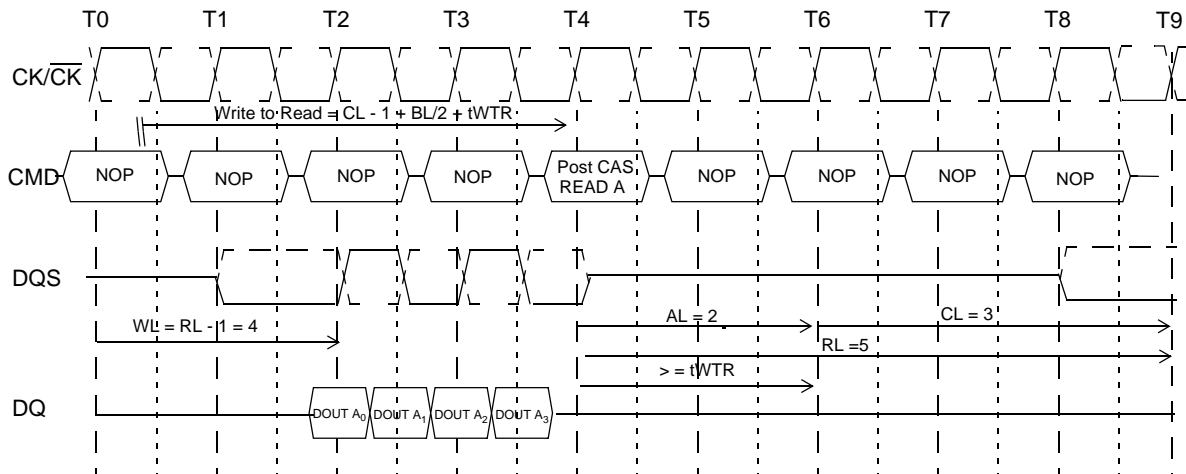

The minimum number of clock from the burst write command to the burst read command is $[CL - 1 + BL/2 + tWTR]$. This tWTR is not a write recovery time (tWR) but the time required to transfer the 4bit write data from the input buffer into sense amplifiers in the array. tWTR is defined in AC spec table of this data sheet.

Seamless Burst Write Operation: RL = 5, WL = 4, BL=4

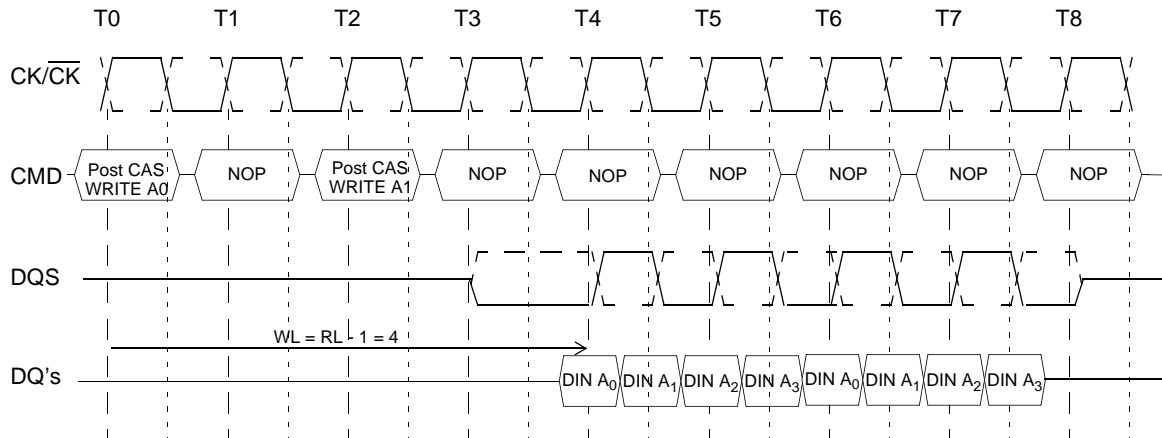

The seamless burst write operation is supported by enabling a write command every other clock for BL = 4 operation, every four clocks for BL = 8 operation. This operation is allowed regardless of same or different banks as long as the banks are activated.

Writes interrupted by a write

Burst write can only be interrupted by another write with 4 bit burst boundary. Any other case of write interrupt is not allowed.

Write Burst Interrupt Timing Example: (CL=3, AL=0, RL=3, WL=2, BL=8)

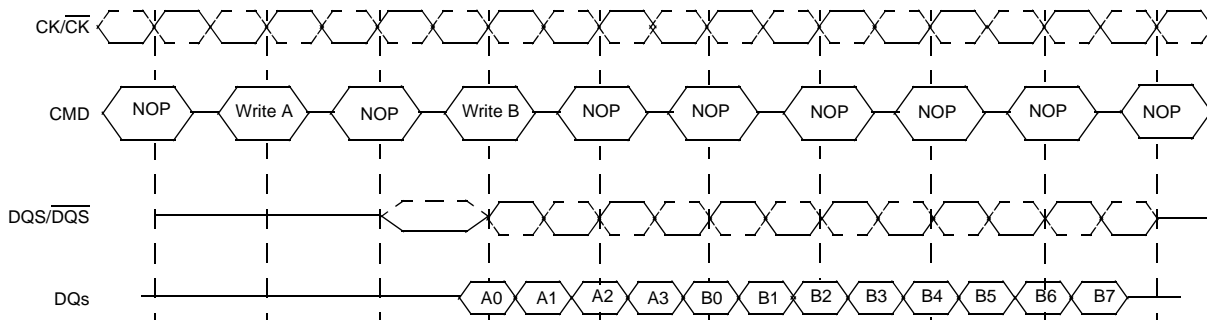

Notes:

1. Write burst interrupt function is only allowed on burst of 8. Burst interrupt of 4 is prohibited.
2. Write burst of 8 can only be interrupted by another Write command. Write burst interruption by Read command or Precharge command is prohibited.
3. Write burst interrupt must occur exactly two clocks after previous Write command. Any other Write burst interrupt timings are prohibited.
4. Write burst interruption is allowed to any bank inside DRAM.
5. Write burst with Auto Precharge enabled is not allowed to interrupt.
6. Write burst interruption is allowed by another Write with Auto Precharge command.
7. All command timings are referenced to burst length set in the mode register. They are not referenced to actual burst. For example, minimum Write to Precharge timing is $WL+BL/2+tWR$ where tWR starts with the rising clock after the un-interrupted burst end and not from the end of actual burst end.

Write data mask

One write data mask (DM) pin for each 8 data bits (DQ) will be supported on gDDR2 SDRAMs, Consistent with the implementation on gDDR SDRAMs. It has identical timings on write operations as the data bits, and though used in a uni-directional manner, is internally loaded identically to data bits to insure matched system timing. DM of x16 bit organization is not used during read cycles.

Data Mask Timing

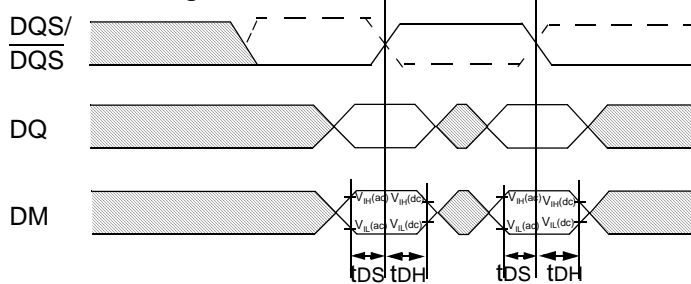

Data Mask Function, WL=3, AL=0, BL = 4 shown

Case 1 : min tDQSS

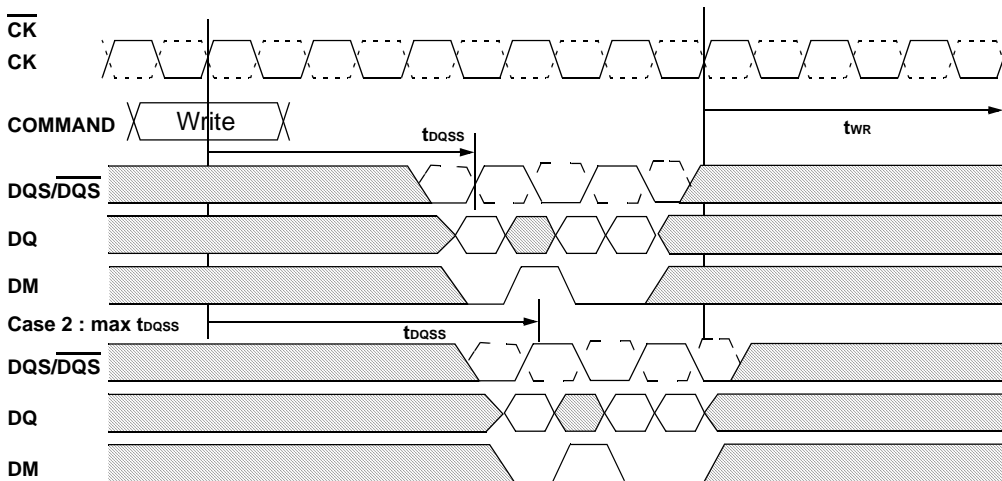

Case 2 : max tDQSS

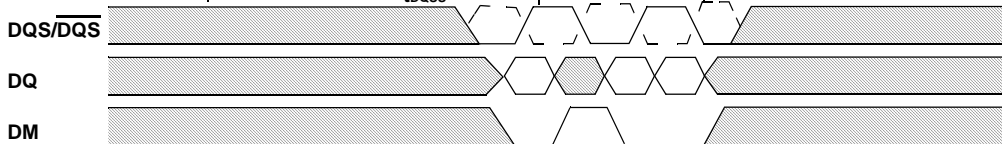

Precharge Command

The Precharge Command is used to precharge or close a bank that has been activated. The Precharge Command is triggered when \overline{CS} , \overline{RAS} and \overline{WE} are low and \overline{CAS} is high at the rising edge of the clock. The Precharge Command can be used to precharge each bank independently or all banks simultaneously. Three address bits A10, BA0 and BA1 for 256Mb are used to define which bank to precharge when the command is issued.

Bank Selection for Precharge by Address Bits

A10	BA1	BA0	Precharged Bank(s)	Remarks
LOW	LOW	LOW	Bank 0 only	
LOW	LOW	HIGH	Bank 1 only	
LOW	HIGH	LOW	Bank 2 only	
LOW	HIGH	HIGH	Bank 3 only	
HIGH	DON'T CARE	DON'T CARE	All Banks	

Burst Read Operation Followed by Precharge

Minimum Read to precharge command spacing to the same bank = $AL + BL/2$ clocks.
 For the earliest possible precharge, the precharge command may be issued on the rising edge which is "Additive latency(AL) + BL/2 clocks" after a Read command. A new bank active (command) may be issued to the same bank after the RAS precharge time (t_{RP}). A precharge command cannot be issued until t_{RAS} is satisfied.
 The minimum Read to Precharge spacing has also to satisfy a minimum analog time from the rising clock edge that initiates the last 4-bit prefetch of a Read to Precharge command. This time is called t_{RTP} (Read to Precharge). For BL = 4 this is the time from the actual read (AL after the Read command) to Precharge command. For BL = 8 this is the time from AL + 2 clocks after the Read to the Precharge command.

Example 1: Burst Read Operation Followed by Precharge:
 RL = 4, AL = 1, CL = 3, BL = 4, $t_{RTP} \leq 2$ clocks

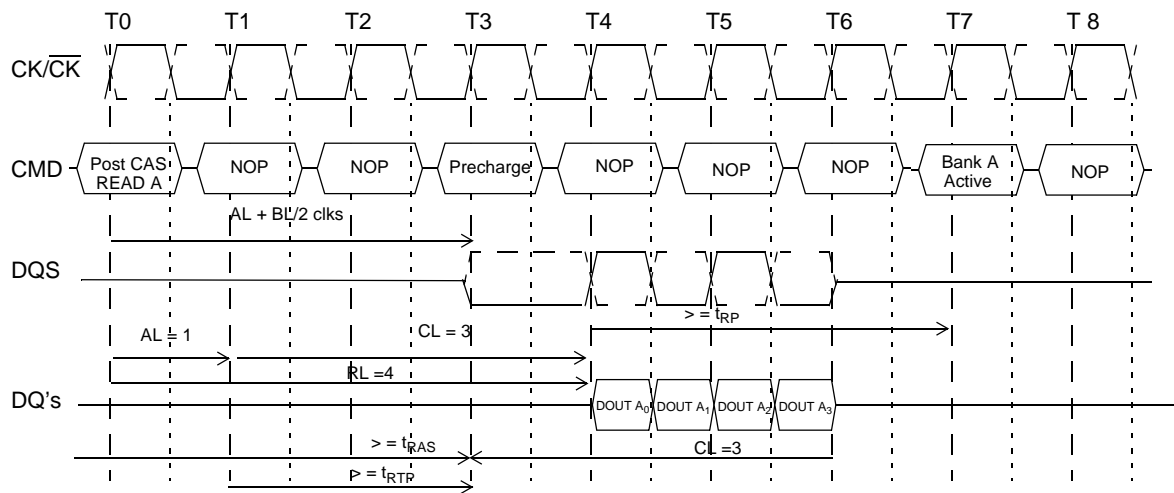

Example 2: Burst Read Operation Followed by Precharge:
 RL = 4, AL = 1, CL = 3, BL = 8, $t_{RTP} \leq 2$ clocks

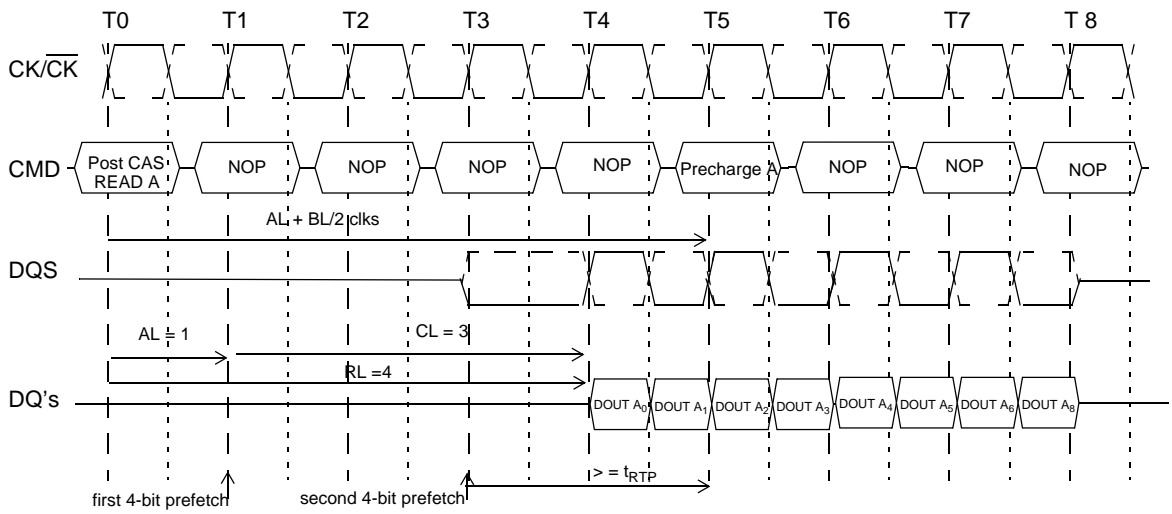

Example 3: Burst Read Operation Followed by Precharge :
 RL = 5, AL = 2, CL = 3, BL = 4, $t_{RTP} \leq 2$ clocks

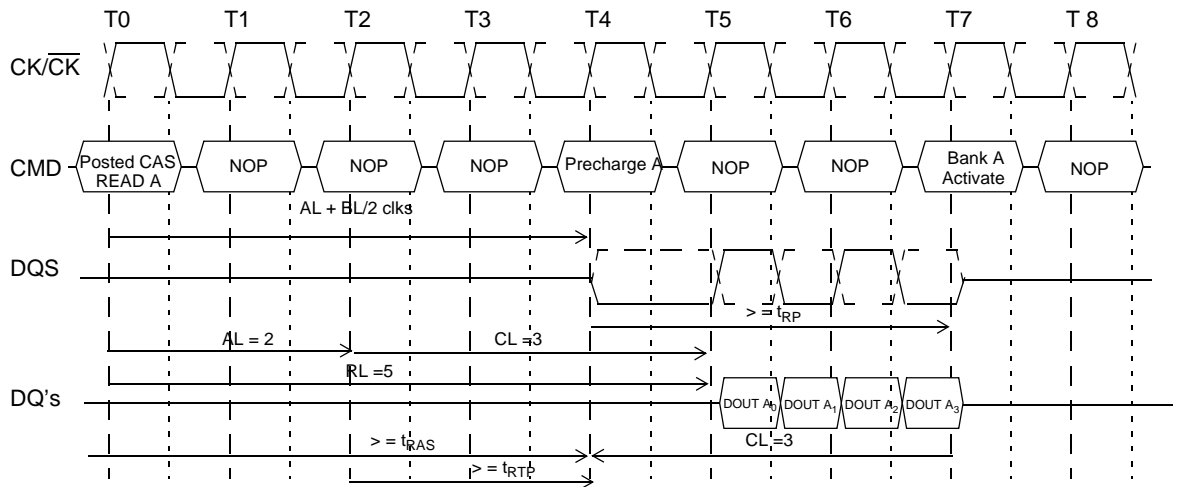

Example 4: Burst Read Operation Followed by Precharge :
 RL = 6, AL = 2, CL = 4, BL = 4, $t_{RTP} \leq 2$ clocks

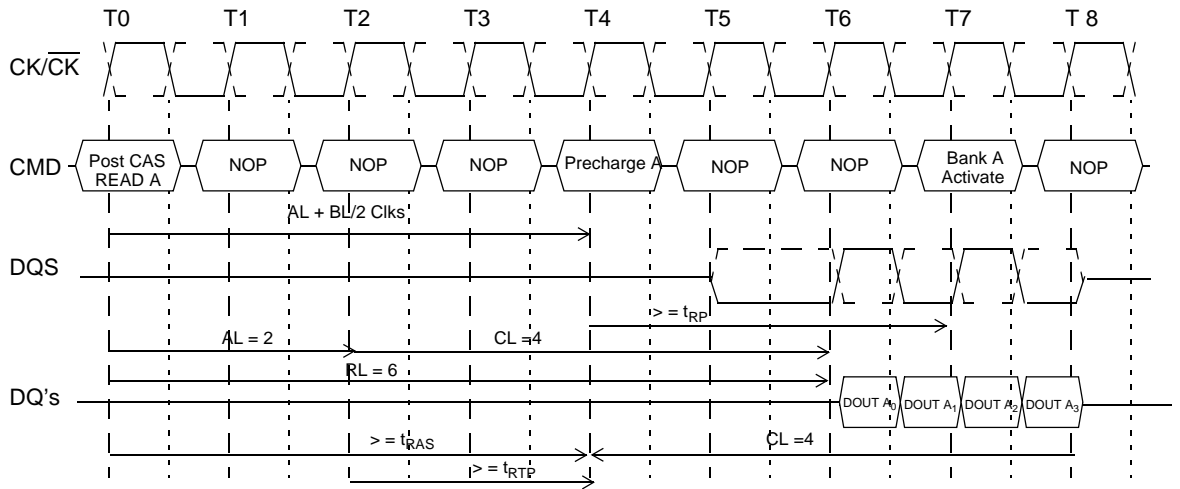

Example 5: Burst Read Operation Followed by Precharge :
 RL = 4, AL = 0, CL = 4, BL = 8, $t_{RTP} > 2$ clocks

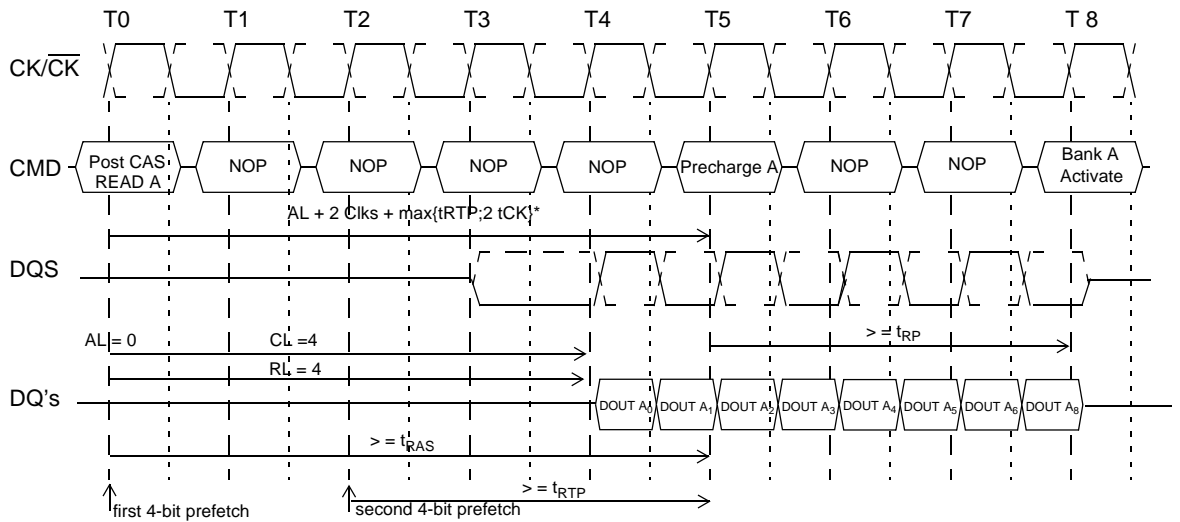

* : rounded to next integer

Burst Write followed by Precharge

Minimum Write to Precharge Command spacing to the same bank = $WL + BL/2$ clks + t_{WR} For write cycles, a delay must be satisfied from the completion of the last burst write cycle until the Precharge Command can be issued. This delay is known as a write recovery time (t_{WR}) referenced from the completion of the burst write to the precharge command. No Precharge command should be issued prior to the t_{WR} delay.

Example 1 : Burst Write followed by Precharge: $WL = (RL-1) = 3, BL=4$

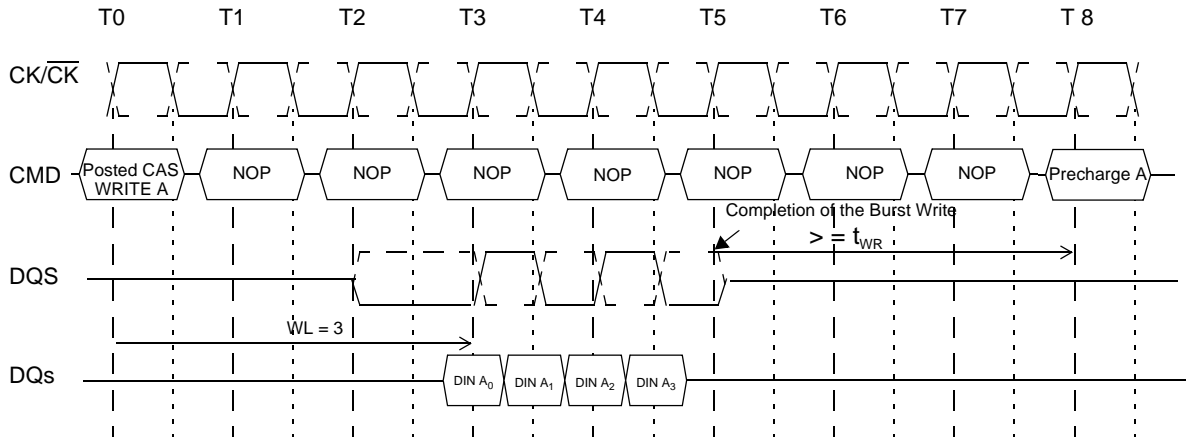

Example 2 : Burst Write followed by Precharge: $WL = (RL-1) = 4, BL=4$

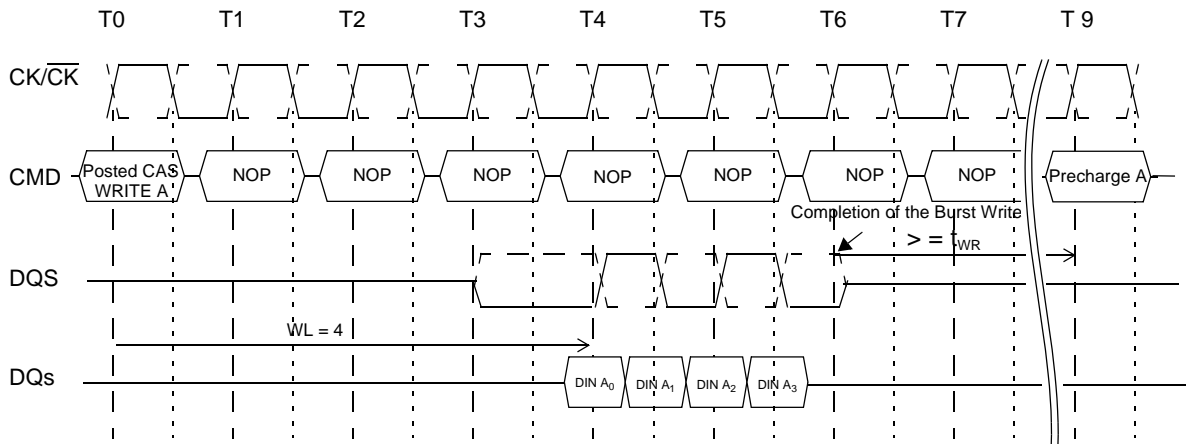

Auto-Precharge Operation

Before a new row in an active bank can be opened, the active bank must be precharged using either the Precharge Command or the auto-precharge function. When a Read or a Write Command is given to the gDDR2 SDRAM, the CAS timing accepts one extra address, column address A10, to allow the active bank to automatically begin precharge at the earliest possible moment during the burst read or write cycle. If A10 is low when the READ or WRITE Command is issued, then normal Read or Write burst operation is executed and the bank remains active at the completion of the burst sequence. If A10 is high when the Read or Write Command is issued, then the auto-precharge function is engaged. During auto-precharge, a Read Command will execute as normal with the exception that the active bank will begin to precharge on the rising edge which is $\overline{\text{CAS}}$ latency (CL) clock cycles before the end of the read burst.

Auto-precharge also be implemented during Write commands. The precharge operation engaged by the Auto precharge command will not begin until the last data of the burst write sequence is properly stored in the memory array.

This feature allows the precharge operation to be partially or completely hidden during burst read cycles (dependent upon $\overline{\text{CAS}}$ latency) thus improving system performance for random data access. The RAS lockout circuit internally delays the Precharge operation until the array restore operation has been completed (tRAS satisfied) so that the auto precharge command may be issued with any read or write command.

Burst Read with Auto Precharge

If A10 is high when a Read Command is issued, the Read with Auto-Precharge function is engaged. The gDDR2 SDRAM starts an auto Precharge operation on the rising edge which is $(AL + BL/2)$ cycles later than the read with AP command if tRAS(min) and tRTP are satisfied.

If tRAS(min) is not satisfied at the edge, the start point of auto-precharge operation will be delayed until tRAS(min) is satisfied.

If tRTP(min) is not satisfied at the edge, the start point of auto-precharge operation will be delayed until tRTP(min) is satisfied. In case the internal precharge is pushed out by tRTP, tRP starts at the point where the internal precharge happens (not at the next rising clock edge after this event). So for BL = 4 the minimum time from Read_AP to the next Activate command becomes $AL + (tRTP + tRP)^*$ (see example 2) for BL = 8 the time from Read_AP to the next Activate is $AL + 2 + (tRTP + tRP)^*$, where "*" means: "rounded up to the next integer". In any event internal precharge does not start earlier than two clocks after the last 4-bit prefetch.

A new bank activate (command) may be issued to the same bank if the following two conditions are satisfied simultaneously.

- (1) The RAS precharge time (tRP) has been satisfied from the clock at which the auto precharge begins.
- (2) The RAS cycle time (tRC) from the previous bank activation has been satisfied.

Example 1: Burst Read Operation with Auto Precharge:
 RL = 4, AL = 1, CL = 3, BL = 8, $t_{RTP} \leq 2$ clocks

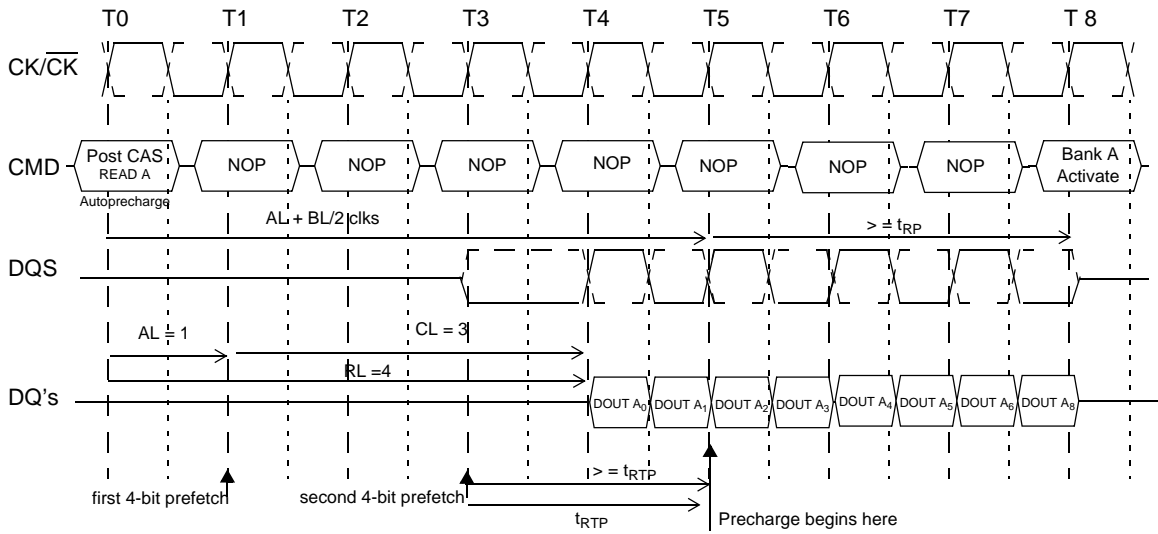

Example 2: Burst Read Operation with Auto Precharge:
 RL = 4, AL = 1, CL = 3, BL = 4, $t_{RTP} > 2$ clocks

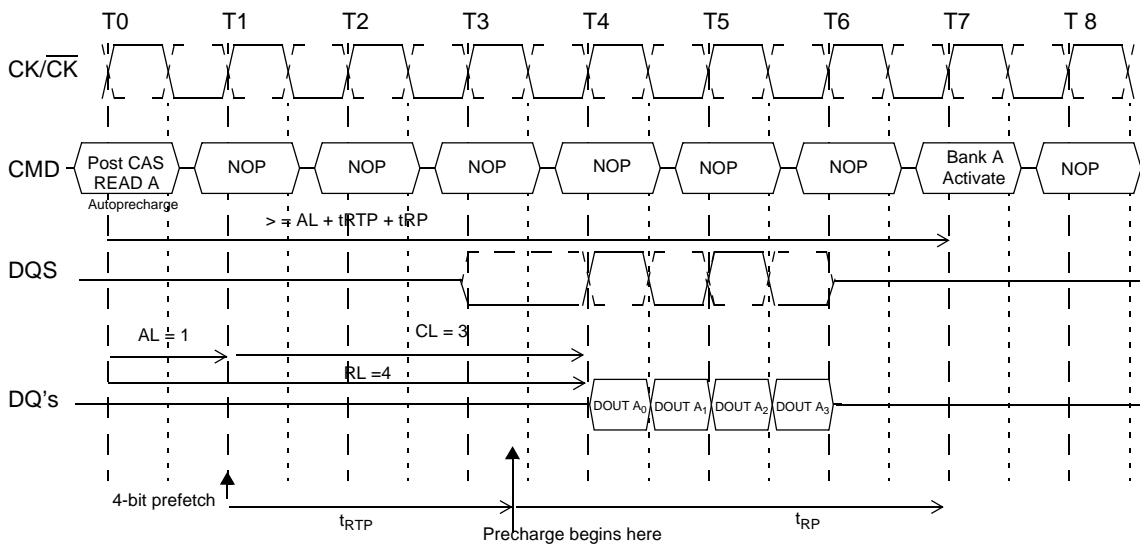

Example 3: Burst Read with Auto Precharge Followed by an activation to the Same Bank
 (tRC Limit):

RL = 5 (AL = 2, CL = 3, internal tRCD = 3, BL = 4, tRTP <= 2 clocks)

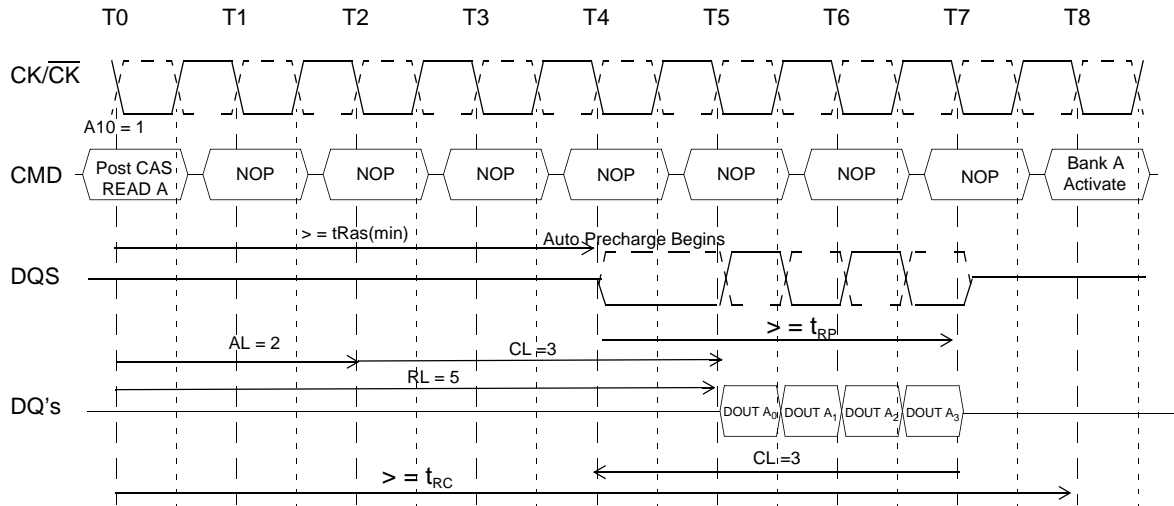

Example 4: Burst Read with Auto Precharge Followed by an Activation to the Same Bank
 (tRP Limit):

RL = 5 (AL = 2, CL = 3, internal tRCD = 3, BL = 4, tRTP <= 2 clocks)

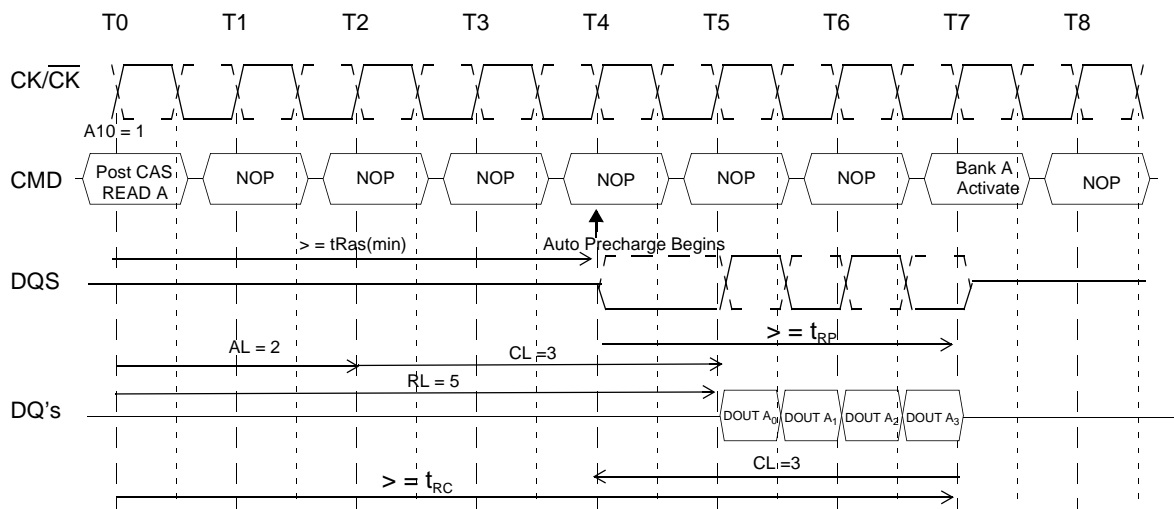

Burst Write with Auto-Precharge

If A10 is high when a Write Command is issued, the Write with Auto-Precharge function is engaged. The gDDR2 SDRAM automatically begins precharge operation after the completion of the burst write plus write recovery time (t_{WR}). The bank undergoing auto-precharge from the completion of the write burst may be reactivated if the following two conditions are satisfied.

- (1) The data-in to bank activate delay time ($WR + t_{RP}$) has been satisfied.
- (2) The RAS cycle time (t_{RC}) from the previous bank activation has been satisfied.

Burst Write with Auto-Precharge (t_{RC} Limit): $WL = 2, t_{WR} = 2, t_{RP} = 3, BL = 4$

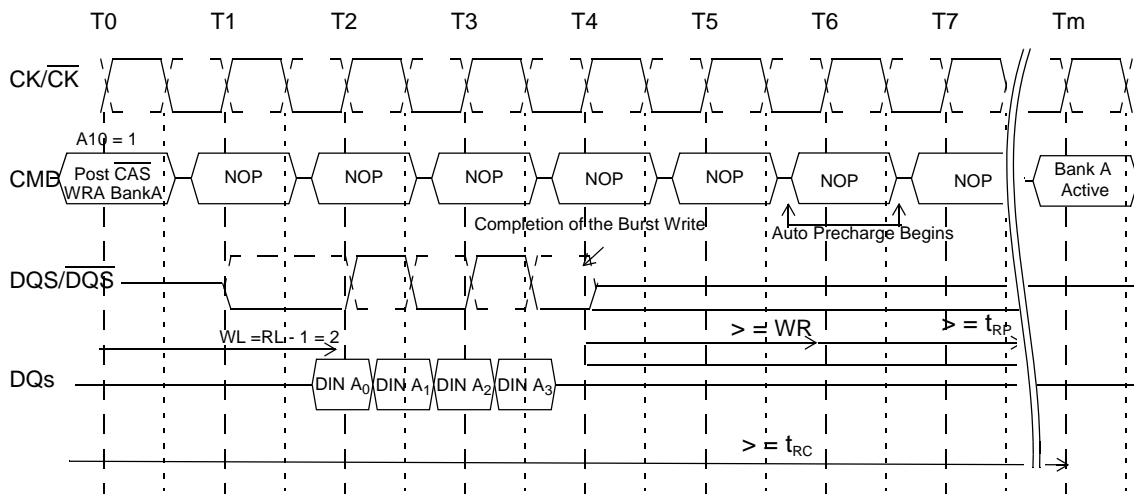

Burst Write with Auto-Precharge ($t_{WR} + t_{RP}$): $WL = 4, t_{WR} = 2, t_{RP} = 3, BL = 4$

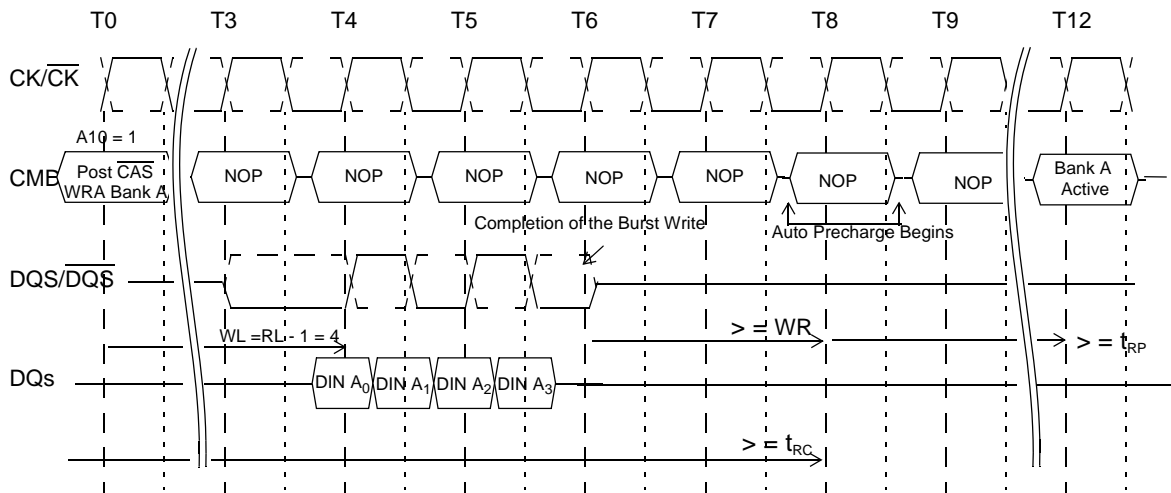

Precharge & Auto Precharge Clarification

From Command	To Command	Minimum Delay between "From Command" to "To Command"	Unit	Note
Read w/AP	Precharge (to same Bank as Read w/AP)	$AL + BL/2 + tRTP - 2 * tCK$	clks	1, 2
	Precharge All	$AL + BL/2 + tRTP - 2 * tCK$	clks	1, 2
Write w/AP	Precharge (to same Bank as Write w/AP)	$WL + BL/2 + WR$	clks	2
	Precharge All	$WL + BL/2 + WR$	clks	2
Precharge	Precharge (to same Bank as Precharge)	$1 * tCK$	clks	2
	Precharge All	$1 * tCK$	clks	2
Precharge All	Precharge	$1 * tCK$	clks	2
	Precharge All	$1 * tCK$	clks	2

Note :

1. The value of $tRTP$ is decided by the equation : $\max(RU \langle tRTP/tCK \rangle, 2)$ where RU stands for round up. This is required to cover the max tCK case, which is 8 ns.
2. For a given bank, the precharge period of tRP should be counted from the latest precharge command issued to that bank. Similarly, the precharge period of $tRPall$ should be counted from the latest precharge all command issued to the DRAM.

Refresh Command

When \overline{CS} , \overline{RAS} and \overline{CAS} are held low and \overline{WE} high at the rising edge of the clock, the chip enters the Refresh mode (REF). All banks of the gDDR2 SDRAM must be precharged and idle for a minimum of the Precharge time (tRP) before the Refresh command (REF) can be applied. An address counter, internal to the device, supplies the bank address during the refresh cycle. No control of the external address bus is required once this cycle has started.

When the refresh cycle has completed, all banks of the gDDR2 SDRAM will be in the precharged (idle) state. A delay between the Refresh command (REF) and the next Activate command or subsequent Refresh command must be greater than or equal to the Refresh cycle time ($tRFC$).

To allow for improved efficiency in scheduling and switching between tasks, some flexibility in the absolute refresh interval is provided. A maximum of eight Refresh commands can be posted to any given gDDR2 SDRAM, meaning that the maximum absolute interval between any Refresh command and the next Refresh command is $9 * tREFI$.

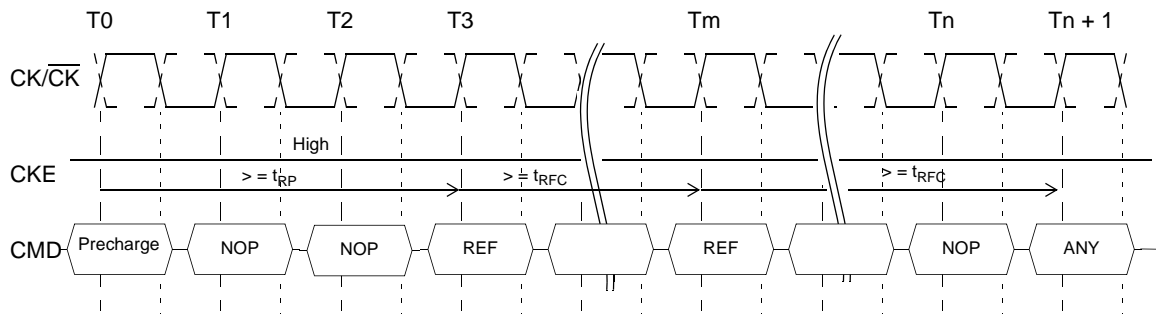

Self Refresh Operation

The gDDR2 SDRAM device has a built-in timer to accommodate Self Refresh operation. The Self Refresh Command is defined by having \overline{CS} , \overline{RAS} , \overline{CAS} and \overline{CKE} held low with \overline{WE} high at the rising edge of the clock. ODT must be turned off before issuing Self Refresh command, by either driving ODT pin low or using EMRS command. Once the Command is registered, \overline{CKE} must be held low to keep the device in Self Refresh mode. When the gDDR2 SDRAM has entered Self Refresh mode all of the external signals except \overline{CKE} , are "don't care". Since \overline{CKE} is an SSTL 2 input, V_{REF} must be maintained during Self Refresh operation. The DRAM initiates a minimum of one one Auto Refresh command internally within t_{CKE} period once it enters Self Refresh mode. The clock is internally disabled during Self Refresh Operation to save power. The minimum time that the gDDR2 SDRAM must remain in Self Refresh mode is t_{CKE} . The user may change the external clock frequency or halt the external clock one clock after Self-Refresh entry is registered, however, the clock must be restarted and stable before the device can exit Self Refresh operation. Once Self Refresh Exit command is registered, a delay equal or longer than the t_{XSNR} or t_{XSRD} must be satisfied before a valid command can be issued to the device. \overline{CKE} must remain high for the entire Self Refresh exit period t_{XSRD} for proper operation. Upon exit from Self Refresh, the gDDR2 SDRAM can be put back into Self Refresh mode after t_{XSRD} expires. NOP or deselect commands must be registered on each positive clock edge during the Self Refresh exit interval. ODT should also be turned off during t_{XSRD} . Upon exit from Self Refresh, the gDDR2 SDRAM requires a minimum of one extra auto refresh command before it is put back into Self Refresh mode.

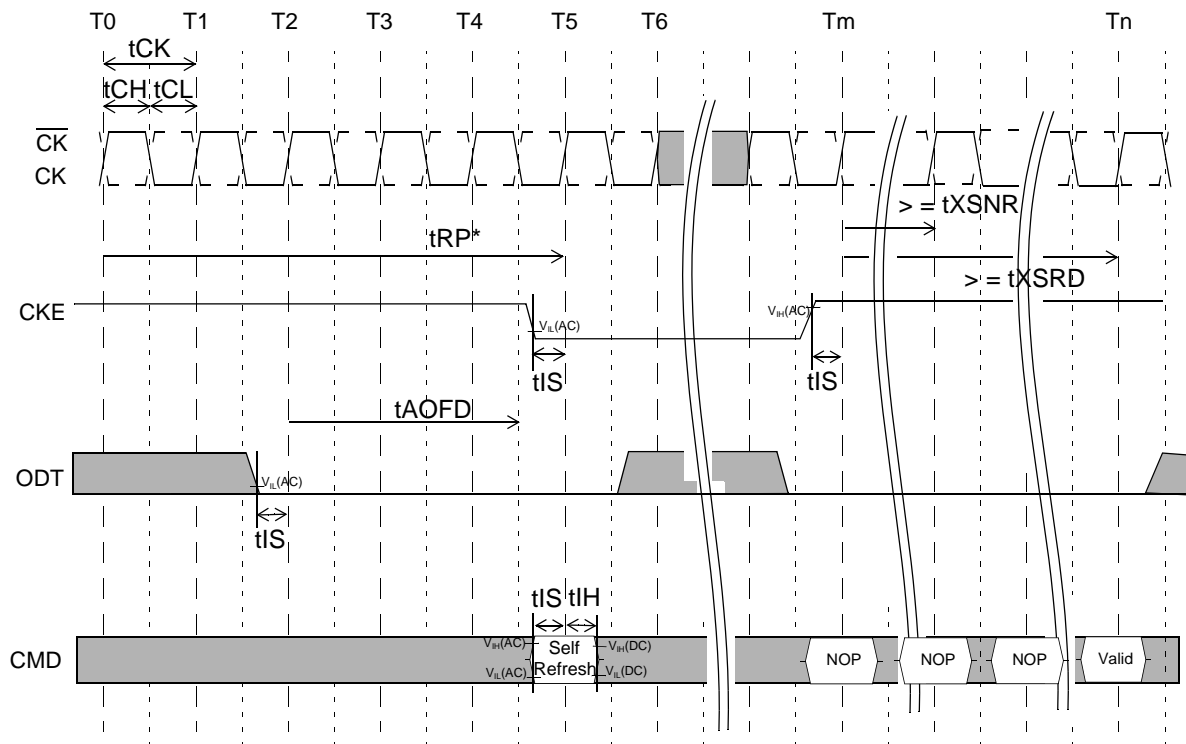

- Device must be in the "All banks idle" state prior to entering Self Refresh mode.
- ODT must be turned off t_{AOFD} before entering Self Refresh mode, and can be turned on again when t_{XSRD} timing is satisfied.
- t_{XSRD} is applied for a Read or a Read with autoprecharge command.
- t_{XSNR} is applied for any command except a Read or a Read with autoprecharge command.

Power-Down

Power-down is synchronously entered when CKE is registered low (along with Nop or Deselect command). CKE is not allowed to go low while mode register or extended mode register command time, or read or write operation is in progress. CKE is allowed to go low while any of other operations such as row activation, precharge or autoprecharge, or auto-refresh is in progress, but power-down IDD spec will not be applied until finishing those operations. Timing diagrams are shown in the following pages with details for entry into power down.

The DLL should be in a locked state when power-down is entered. Otherwise DLL should be reset after exiting power-down mode for proper read operation. DRAM design guarantees it's DLL in a locked state with any CKE intensive operations as long as DRAM controller complies with DRAM specifications. Following figures show two examples of CKE intensive applications. In both examples, DRAM maintains DLL in a locked state throughout the period.

<Example of CKE intensive environment 1>

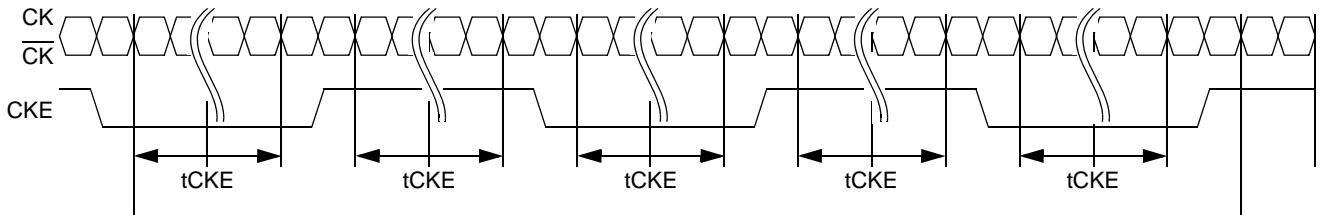

DRAM guarantees all AC and DC timing & voltage specifications and proper DLL operation with intensive CKE operation

<Example of CKE intensive environment 2>

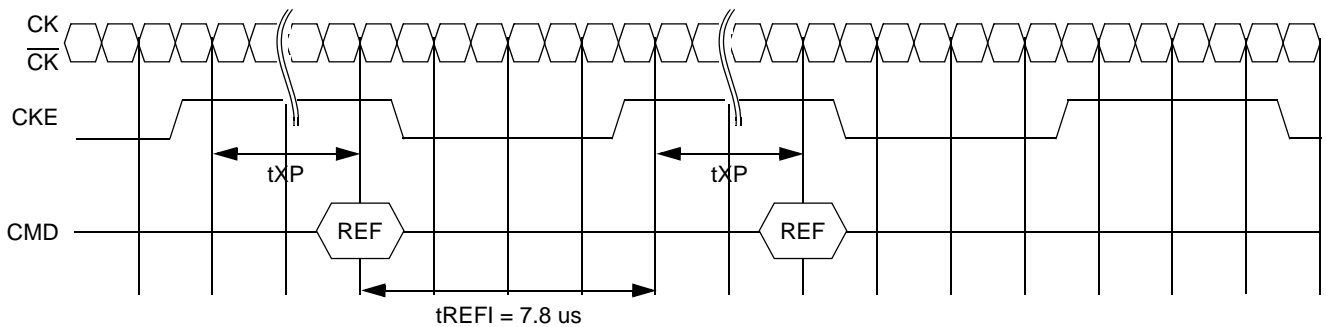

The pattern shown above can repeat over a long period of time. With this pattern, DRAM guarantees all DRAM guarantees all AC and DC timing & voltage specifications and DLL operation with temperature and voltage drift.

If power-down occurs when all banks are idle, this mode is referred to as precharge power-down; if power-down occurs when there is a row active in any bank, this mode is referred to as active power-down. Entering power-down deactivates the input and output buffers, excluding CK, $\overline{\text{CK}}$, ODT and CKE. Also the DLL is disabled upon entering precharge power-down or slow exit active power-down, but the DLL is kept enabled during fast exit active power-down. In power-down mode, CKE low and a stable clock signal must be maintained at the inputs of the gDDR2 SDRAM, and ODT should be in a valid state but all other input signals are "Don't Care". CKE low must be maintained until t_{CKE} has been satisfied. Power-down duration is limited by 9 times tREFI of the device.

The power-down state is synchronously exited when CKE is registered high (along with a Nop or Deselect command). CKE high must be maintained until t_{CKE} has been satisfied. A valid, executable command can be applied with power-down exit latency, t_{XP}, t_{XARD}, or t_{XARDS}, after CKE goes high. Power-down exit latency is defined at AC spec table of this data sheet.

Basic Power Down Entry and Exit timing diagram

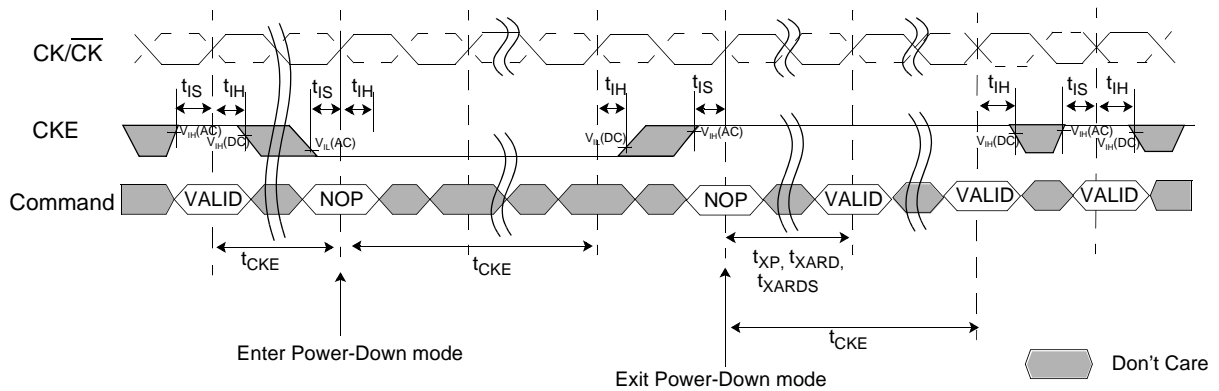

Read to power down entry

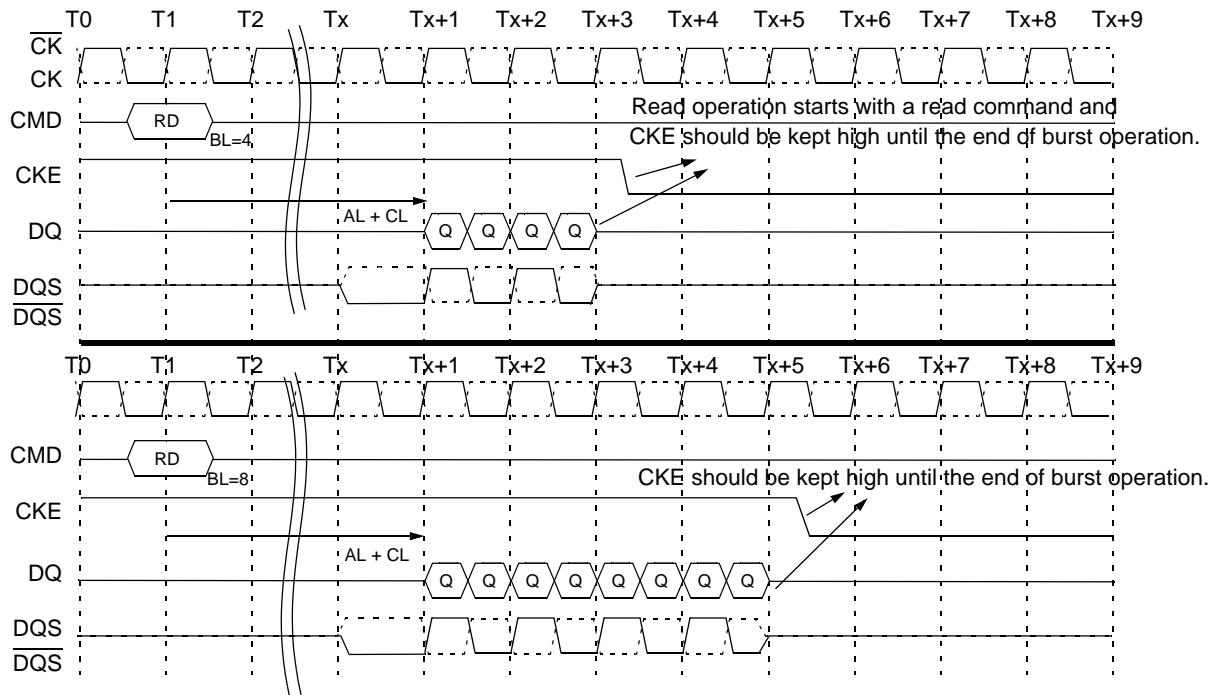

Read with Autoprecharge to power down entry

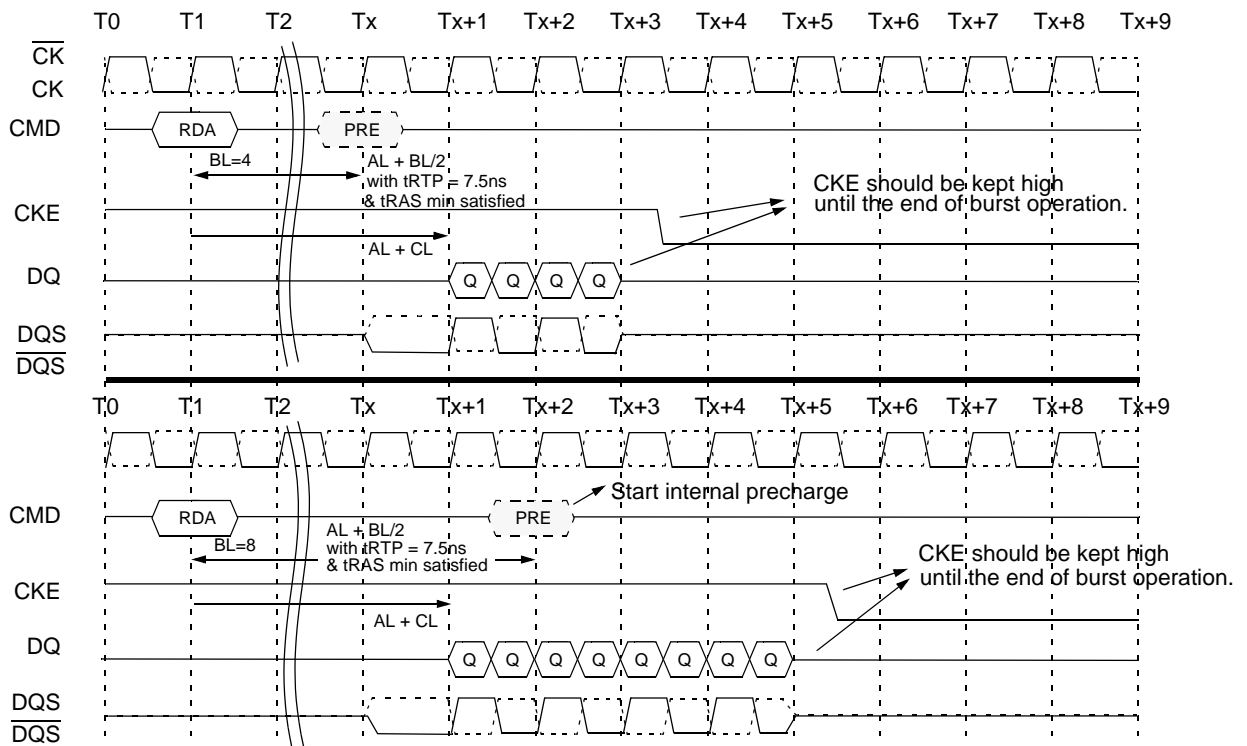

Write to power down entry

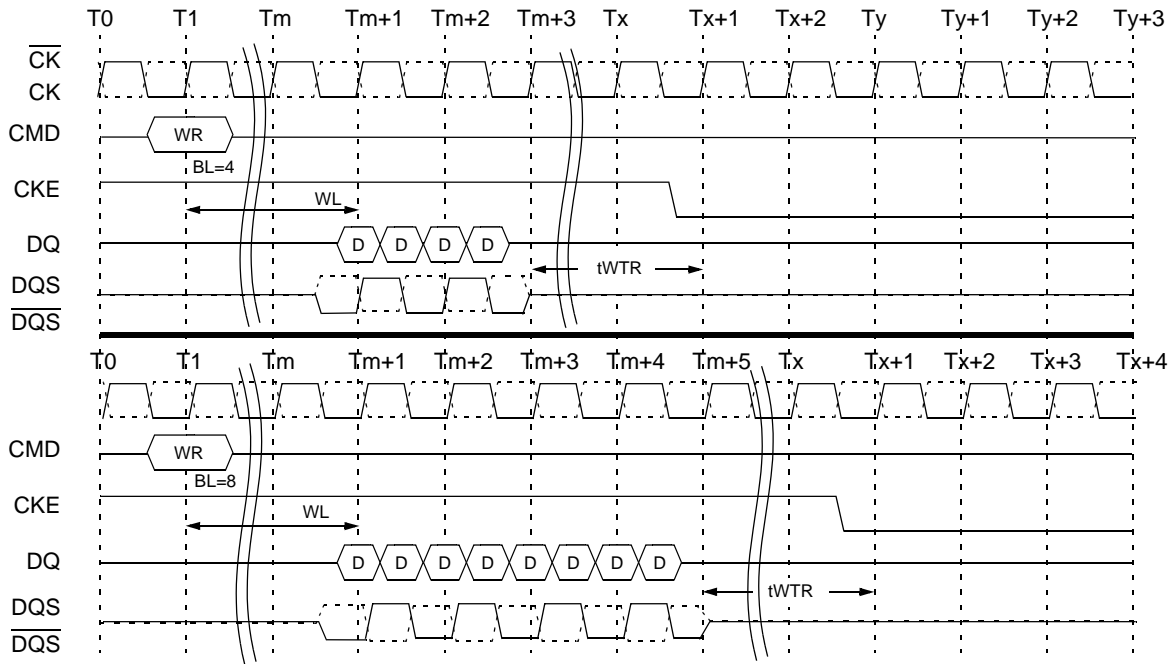

Write with Autoprecharge to power down entry

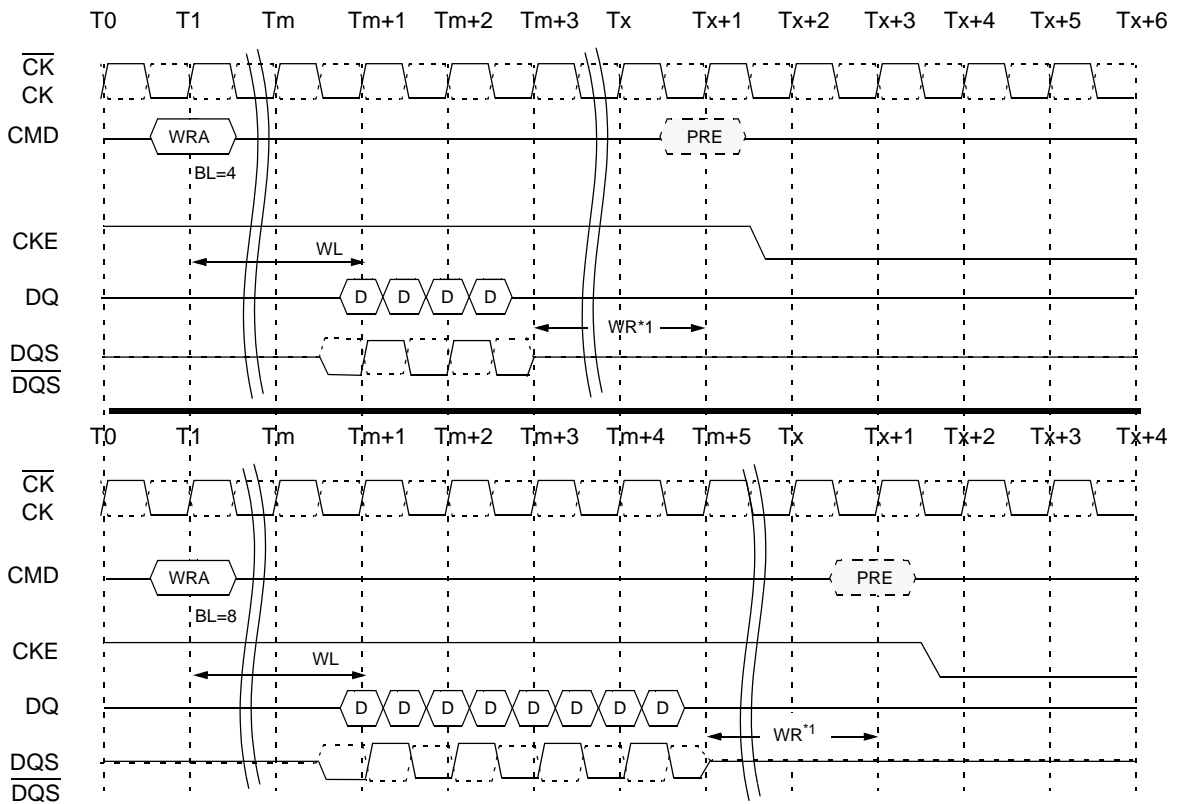

* 1: WR is programmed through MRS

Refresh command to power down entry

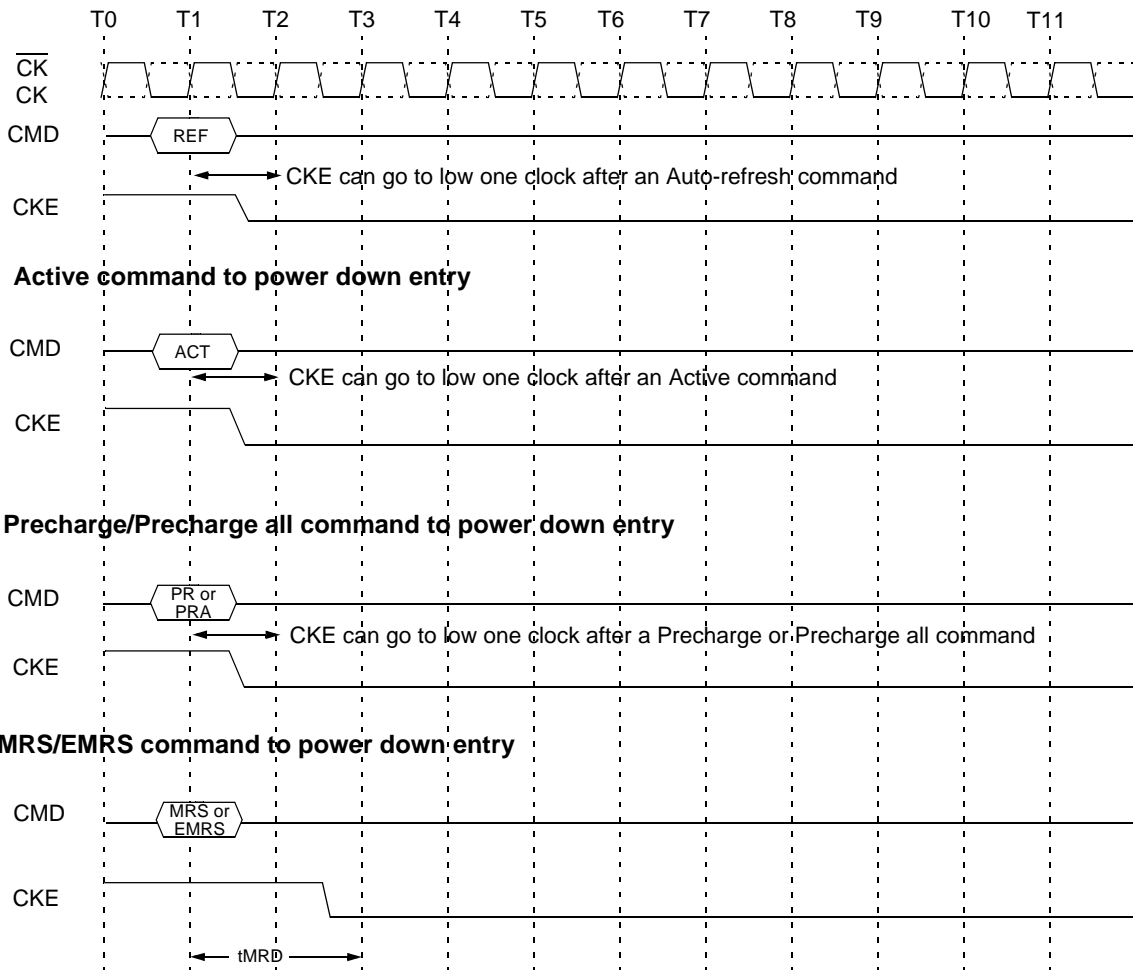

Asynchronous CKE Low Event

DRAM requires CKE to be maintained "HIGH" for all valid operations as defined in this data sheet. If CKE asynchronously drops "LOW" during any valid operation DRAM is not guaranteed to preserve the contents of array. If this event occurs, memory controller must satisfy DRAM timing specification tDelay before turning off the clocks. Stable clocks must exist at the input of DRAM before CKE is raised "HIGH" again. DRAM must be fully re-initialized (steps 4 thru 13) as described in initialization sequence. DRAM is ready for normal operation after the initialization sequence. See AC timing parametric table for tDelay specification.

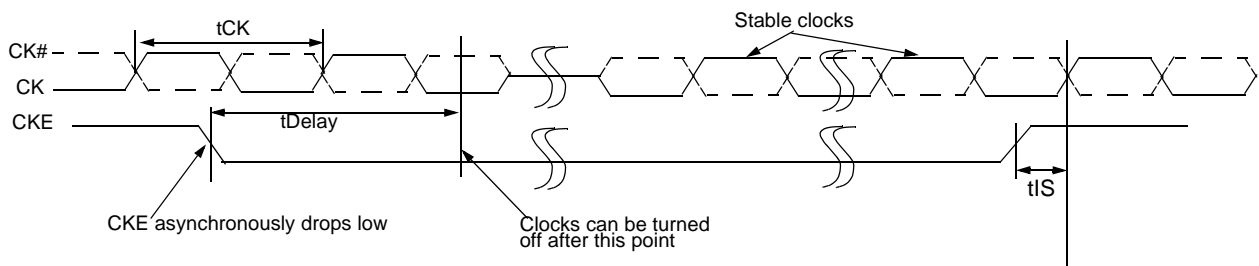

Input Clock Frequency Change during Precharge Power Down

gDDR2 SDRAM input clock frequency can be changed under following condition :

gDDR2 SDRAM is in precharged power down mode. ODT must be turned off and CKE must be at logic LOW level. A minimum of 2 clocks must be waited after CKE goes LOW before clock frequency may change. SDRAM input clock frequency is allowed to change only within minimum and maximum operating frequency specified for the particular speed grade. During input clock frequency change, ODT and CKE must be held at stable LOW levels. Once input clock frequency is changed, stable new clocks must be provided to DRAM before precharge power down may be exited and DLL must be RESET via EMRS after precharge power down exit. Depending on new clock frequency an additional MRS command may need to be issued to appropriately set the WR, CL etc.. During DLL re-lock period, ODT must remain off. After the DLL lock time, the DRAM is ready to operate with new clock frequency.

Clock Frequency Change in Precharge Power Down Mode

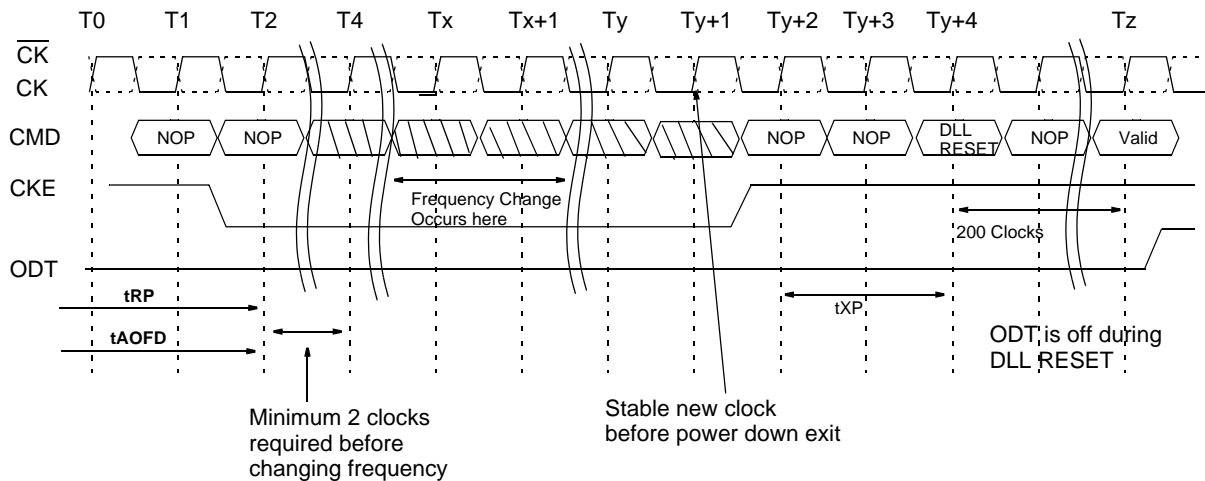

No Operation Command

The No Operation Command should be used in cases when the gDDR2 SDRAM is in an idle or a wait state. The purpose of the No Operation Command (NOP) is to prevent the gDDR2 SDRAM from registering any unwanted commands between operations. A No Operation Command is registered when \overline{CS} is low with RAS, CAS, and WE held high at the rising edge of the clock. A No Operation Command will not terminate a previous operation that is still executing, such as a burst read or write cycle.

Deselect Command

The Deselect Command performs the same function as a No Operation Command. Deselect Command occurs when \overline{CS} is brought high at the rising edge of the clock, the RAS, CAS, and WE signals become don't cares.

Command Truth Table

Function	CKE		$\overline{\text{CS}}$	$\overline{\text{RAS}}$	$\overline{\text{CAS}}$	$\overline{\text{WE}}$	BA0 BA1	A11	A10	A9 - A0	Note
	Previous Cycle	Current Cycle									
(Extended) Mode Register Set	H	H	L	L	L	L	BA	OP Code			1,2
Refresh (REF)	H	H	L	L	L	H	X	X	X	X	1
Self Refresh Entry	H	L	L	L	L	H	X	X	X	X	1,8
Self Refresh Exit	L	H	H	X	X	X	X	X	X	X	1,7
			L	H	H	H					
Single Bank Precharge	H	H	L	L	H	L	BA	X	L	X	1,2
Precharge all Banks	H	H	L	L	H	L	X	X	H	X	1
Bank Activate	H	H	L	L	H	H	BA	Row Address			1,2
Write	H	H	L	H	L	L	BA	Column	L	Column	1,2,3
Write with Auto Precharge	H	H	L	H	L	L	BA	Column	H	Column	1,2,3
Read	H	H	L	H	L	H	BA	Column	L	Column	1,2,3
Read with Auto-Precharge	H	H	L	H	L	H	BA	Column	H	Column	1,2,3
No Operation	H	X	L	H	H	H	X	X	X	X	1
Device Deselect	H	X	H	X	X	X	X	X	X	X	1
Power Down Entry	H	L	H	X	X	X	X	X	X	X	1,4
			L	H	H	H					
Power Down Exit	L	H	H	X	X	X	X	X	X	X	1,4
			L	H	H	H					

Note :

1. All gDDR2 SDRAM commands are defined by states of $\overline{\text{CS}}$, $\overline{\text{RAS}}$, $\overline{\text{CAS}}$, $\overline{\text{WE}}$ and CKE at the rising edge of the clock.
2. Bank addresses BA0, BA1, BA2 (BA) determine which bank is to be operated upon. For (E)MRS BA selects an (Extended) Mode Register.
3. Burst reads or writes at BL=4 cannot be terminated or interrupted. See sections "Reads interrupted by a Read" and "Writes interrupted by a Write"
4. The Power Down Mode does not perform any refresh operations. The duration of Power Down is therefore limited by the refresh requirements outlined.
5. The state of ODT does not affect the states described in this table. The ODT function is not available during Self Refresh.
6. "X" means "H or L (but a defined logic level)".
7. Self refresh exit is asynchronous.
8. VREF must be maintained during Self Refresh operation.

Clock Enable (CKE) Truth Table for Synchronous Transitions

Current State ²	CKE		Command (N) ³ $\overline{\text{RAS}}, \overline{\text{CAS}}, \overline{\text{WE}}, \overline{\text{CS}}$	Action (N) ³	Note
	Previous Cycle ¹ (N-1)	Current Cycle ¹ (N)			
Power Down	L	L	X	Maintain Power-Down	11, 13, 15
	L	H	DESELECT or NOP	Power Down Exit	4, 8, 11,13
Self Refresh	L	L	X	Maintain Self Refresh	11, 15
	L	H	DESELECT or NOP	Self Refresh Exit	4, 5,9
Bank(s) Active	H	L	DESELECT or NOP	Active Power Down Entry	4,8,10,11,13
All Banks Idle	H	L	DESELECT or NOP	Precharge Power Down Entry	4, 8, 10,11,13
	H	L	REFRESH	Self Refresh Entry	6, 9, 11,13
	H	H	Refer to the Command Truth Table		7

Note :

1. CKE (N) is the logic state of CKE at clock edge N; CKE (N-1) was the state of CKE at the previous clock edge.
2. Current state is the state of the DDR SDRAM immediately prior to clock edge N.
3. COMMAND (N) is the command registered at clock edge N, and ACTION (N) is a result of COMMAND (N).
4. All states and sequences not shown are illegal or reserved unless explicitly described elsewhere in this document.
5. On Self Refresh Exit DESELECT or NOP commands must be issued on every clock edge occurring during the t_{XSNR} period. Read commands may be issued only after t_{XSRD} (200 clocks) is satisfied.
6. Self Refresh mode can only be entered from the All Banks Idle state.
7. Must be a legal command as defined in the Command Truth Table.
8. Valid commands for Power Down Entry and Exit are NOP and DESELECT only.
9. Valid commands for Self Refresh Exit are NOP and DESELECT only.
10. Power Down and Self Refresh can not be entered while Read or Write operations, (Extended) Mode Register Set operations or Precharge operations are in progress. See section "Power Down" and "Self Refresh Command" for a detailed list of restrictions.
11. Minimum CKE high time is three clocks.; minimum CKE low time is three clocks.
12. The state of ODT does not affect the states described in this table. The ODT function is not available during Self Refresh.
13. The Power Down does not perform any refresh operations. The duration of Power Down Mode is therefore limited by the refresh requirements outlined.
14. CKE must be maintained high while the SDRAM is in OCD calibration mode .
15. "X" means "don't care (including floating around VREF)" in Self Refresh and Power Down. However ODT must be driven high or low in Power Down if the ODT function is enabled (Bit A2 or A6 set to "1" in EMRS(1)).
16. V_{REF} must be maintained during Self Refresh operation.

DM Truth Table

Name (Functional)	DM	DQs	Note
Write enable	-	Valid	1
Write inhibit	H	X	1

Note :

1. Used to mask write data, provided coincident with the corresponding data

Input Signal Overshoot/Undershoot Specification

AC Overshoot/Undershoot Specification for Address and Control Pins A0-A15, BA0-BA2, \overline{CS} , \overline{RAS} , \overline{CAS} , \overline{WE} , CKE, ODT

Parameter	Specification
Maximum peak amplitude allowed for overshoot area (See following figure):	0.9V
Maximum peak amplitude allowed for undershoot area (See following figure):	0.9V
Maximum overshoot area above VDD (See following figure).	0.45 V-ns
Maximum undershoot area below VSS (See following figure).	0.45 V-ns

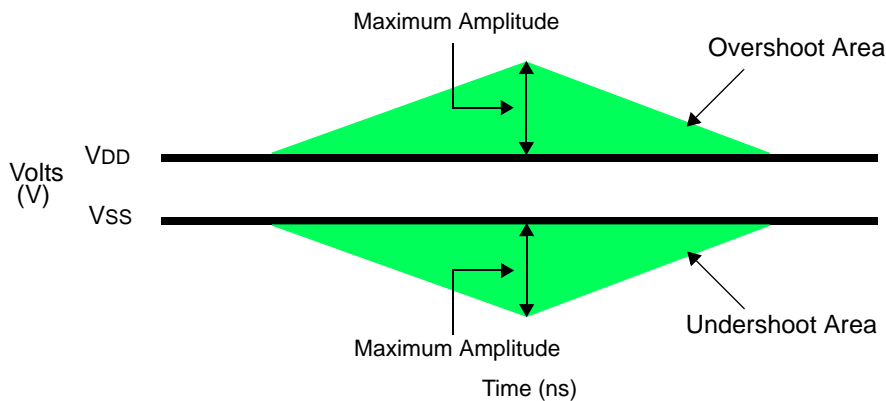

AC Overshoot and Undershoot Definition for Address and Control Pins

AC Overshoot/Undershoot Specification for Clock, Data, Strobe, and Mask Pins DQ, DQS, DM, CK, CK

Parameter	Specification
Maximum peak amplitude allowed for overshoot area (See following figure):	0.9V
Maximum peak amplitude allowed for undershoot area (See following figure):	0.9V
Maximum overshoot area above VDDQ (See following figure):	0.23 V-ns
Maximum undershoot area below VSSQ (See following figure):	0.23 V-ns

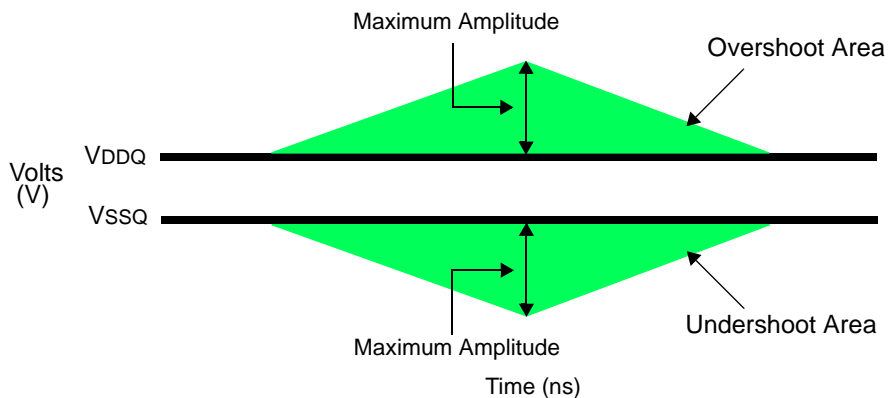

AC Overshoot and Undershoot Definition for Clock, Data, Strobe, and Mask Pins

Table 1. Full Strength Default Pulldown Driver Characteristics

Voltage (V)	Pulldown Current (mA)			
	Minimum (23.4 Ohms)	Nominal Default Low (18 ohms)	Nominal Default High(18 ohms)	Maximum (12.6 Ohms)
0.2	8.5	11.3	11.8	15.9
0.3	12.1	16.5	16.8	23.8
0.4	14.7	21.2	22.1	31.8
0.5	16.4	25.0	27.6	39.7
0.6	17.8	28.3	32.4	47.7
0.7	18.6	30.9	36.9	55.0
0.8	19.0	33.0	40.9	62.3
0.9	19.3	34.5	44.6	69.4
1.0	19.7	35.5	47.7	75.3
1.1	19.9	36.1	50.1	80.5
1.2	20.0	36.6	52.2	84.6
1.3	20.1	36.9	54.2	87.7
1.4	20.2	37.1	55.9	90.8
1.5	20.3	37.4	57.1	92.9
1.6	20.4	37.6	58.4	94.9
1.7	20.6	37.7	59.6	97.0
1.8		37.9	60.9	99.1
1.9				101.1

Figure 1. gDDR2 Default Pulldown Characteristics for Full Strength Driver

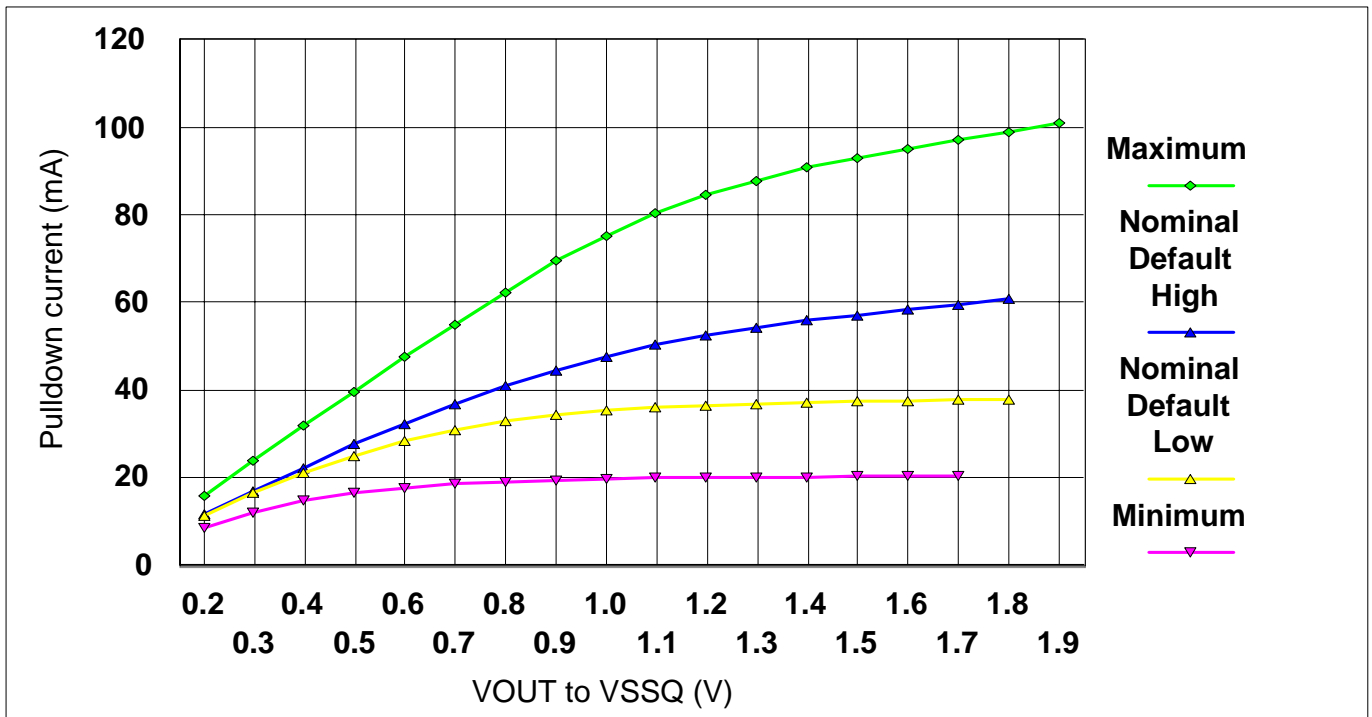
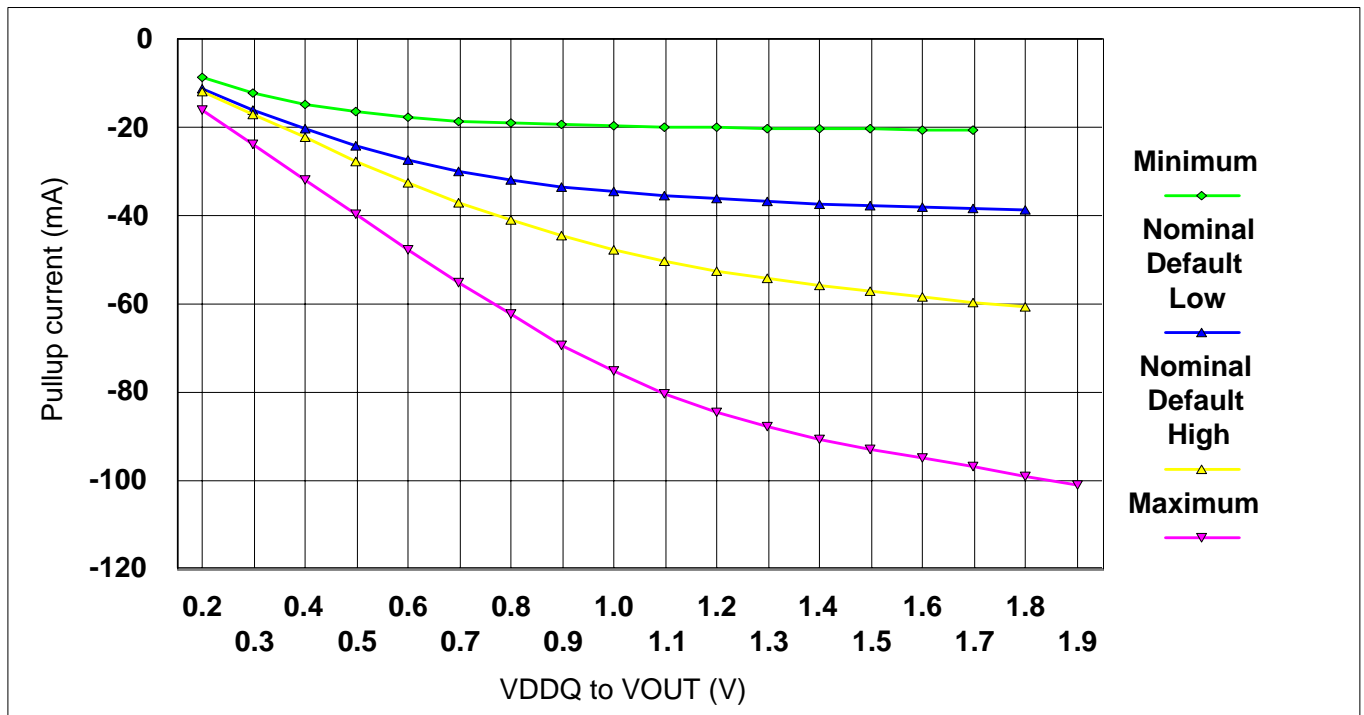

Table 2. Full Strength Default Pullup Driver Characteristics

Voltage (V)	Pulldown Current (mA)			
	Minimum (23.4 Ohms)	Nominal Default Low (18 ohms)	Nominal Default High(18 ohms)	Maximum (12.6 Ohms)
0.2	-8.5	-11.1	-11.8	-15.9
0.3	-12.1	-16.0	-17.0	-23.8
0.4	-14.7	-20.3	-22.2	-31.8
0.5	-16.4	-24.0	-27.5	-39.7
0.6	-17.8	-27.2	-32.4	-47.7
0.7	-18.6	-29.8	-36.9	-55.0
0.8	-19.0	-31.9	-40.8	-62.3
0.9	-19.3	-33.4	-44.5	-69.4
1.0	-19.7	-34.6	-47.7	-75.3
1.1	-19.9	-35.5	-50.4	-80.5
1.2	-20.0	-36.2	-52.5	-84.6
1.3	-20.1	-36.8	-54.2	-87.7
1.4	-20.2	-37.2	-55.9	-90.8
1.5	-20.3	-37.7	-57.1	-92.9
1.6	-20.4	-38.0	-58.4	-94.9
1.7	-20.6	-38.4	-59.6	-97.0
1.8		-38.6	-60.8	-99.1
1.9				-101.1

Figure 2. gDDR2 Default Pullup Characteristics for Full Strength Output Driver



gDDR2 SDRAM Default Output Driver V-I Characteristics

gDDR2 SDRAM output driver characteristics are defined for full strength default operation as selected by the EMRS1 bits A7-A9 = '111'. Figures 1 and 2 show the driver characteristics graphically, and tables 1 and 2 show the same data in tabular format suitable for input into simulation tools. The driver characteristics evaluation conditions are:

Nominal Default 25 °C (T case), VDDQ = 1.8 V, typical process

Minimum TBD °C (T case), VDDQ = 1.7 V, slow-slow process

Maximum 0 °C (T case), VDDQ = 1.9 V, fast-fast process

Default Output Driver Characteristic Curves Notes:

- 1) The full variation in driver current from minimum to maximum process, temperature, and voltage will lie within the outer bounding lines of the V-I curve of figures 1 and 2.
- 2) It is recommended that the "typical" IBIS V-I curve lie within the inner bounding lines of the V-I curves of figures 1 and 2.

Table 3. Full Strength Calibrated Pulldown Driver Characteristics

Voltage (V)	Calibrated Pulldown Current (mA)				
	Nominal Minimum (21 Ohms)	Nominal Low (18.75 ohms)	Nominal (18 ohms)	Nominal High (17.25 ohms)	Nominal Maximum (15 Ohms)
0.2	9.5	10.7	11.5	11.8	13.3
0.3	14.3	16.0	16.6	17.4	20.0
0.4	18.7	21.0	21.6	23.0	27.0

Table 4. Full Strength Calibrated Pullup Driver Characteristics

Voltage (V)	Calibrated Pulldown Current (mA)				
	Nominal Minimum (21 Ohms)	Nominal Low (18.75 ohms)	Nominal (18 ohms)	Nominal High (17.25 ohms)	Nominal Maximum (15 Ohms)
0.2	-9.5	-10.7	-11.4	-11.8	-13.3
0.3	-14.3	-16.0	-16.5	-17.4	-20.0
0.4	-18.7	-21.0	-21.2	-23.0	-27.0

gDDR2 SDRAM Calibrated Output Driver V-I Characteristics

gDDR2 SDRAM output driver characteristics are defined for full strength calibrated operation as selected by the procedure outlined in Off-Chip Driver (OCD) Impedance Adjustment. Tables 3 and 4 show the data in tabular format suitable for input into simulation tools. The nominal points represent a device at exactly 18 ohms. The nominal low and nominal high values represent the range that can be achieved with a maximum 1.5 ohm step size with no calibration error at the exact nominal conditions only (i.e. perfect calibration procedure, 1.5 ohm maximum step size guaranteed by specification). Real system calibration error needs to be added to these values. It must be understood that these V-I curves as represented here or in supplier IBIS models need to be adjusted to a wider range as a result of any system calibration error. Since this is a system specific phenomena, it cannot be quantified here. The values in the calibrated tables represent just the DRAM portion of uncertainty while looking at one DQ only. If the calibration procedure is used, it is possible to cause the device to operate outside the bounds of the default device characteristics tables and figures. In such a situation, the timing parameters in the specification cannot be guaranteed. It is solely up to the system application to ensure that the device is calibrated between the minimum and maximum default values at all times. If this can't be guaranteed by the system calibration procedure, re-calibration policy, and uncertainty with DQ to DQ variation, then it is recommended that only the default values be used. The nominal maximum and minimum values represent the change in impedance from nominal low and high as a result of voltage and temperature change from the nominal condition to the maximum and minimum conditions. If calibrated at an extreme condition, the amount of variation could be as much as from the nominal minimum to the nominal maximum or vice versa. The driver characteristics evaluation conditions are:

Nominal 25 °C (T case), VDDQ = 1.8 V, typical process.

Nominal Low and Nominal High 25 °C (T case), VDDQ = 1.8 V, any process.

Nominal Minimum TBD °C (T case), VDDQ = 1.7 V, any process.

Nominal Maximum 0 °C (T case), VDDQ = 1.9 V, any process.