

# Not recommended items.

## Chip Type Large Capacitance Capacitors

GREEN CAP

SMD

Anti-cleaning solvent

- Compatible with surface mounting.
- Supplied with carrier taping.
- Guarantees 2000 hours at 85°C.

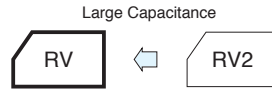

Marking color : Black print (φ8×6.5L)  
White print on a brown sleeve (φ8×10L - φ12.5×13.5L)

### Specifications

Item	Performance									
Category temperature range (°C)	-40 to +85									
Tolerance at rated capacitance (%)	±20 (20°C, 120Hz)									
Leakage current (μA)	Less than 0.01CV or 3 whichever is larger (after 2 minutes) C : Rated capacitance (μF) ; V : Rated voltage (V) (20°C)									
Tangent of loss angle (tanδ)	Rated voltage (V)	6.3	10	16	25	35	50	63	100	
	tanδ (max.)	0.28	0.24	0.20	0.14	0.12	0.10	0.10	0.10	(20°C, 120Hz)
Characteristics at high and low temperature	Rated voltage (V)	6.3	10	16	25	35	50	63	100	
	Impedance ratio (max.)	Z-25°C/Z+20°C	4	3	2	2	2	2	2	2
Endurance (85°C) (Applied ripple current)	Test time	2000 hours								
	Leakage current	The initial specified value or less								
	Percentage of capacitance change	Within ±20% of initial value								
	Tangent of the loss angle	200% or less of the initial specified value								
Shelf life (85°C)	Test time : 1000hours; other items are the same as those for the endurance. Voltage application treatment : According to JIS C5101-1									
Applicable standards	JIS C 5101-1 1998,-18 1999 (IEC 60384-1 1992, -18 1993)									

### Outline Drawing

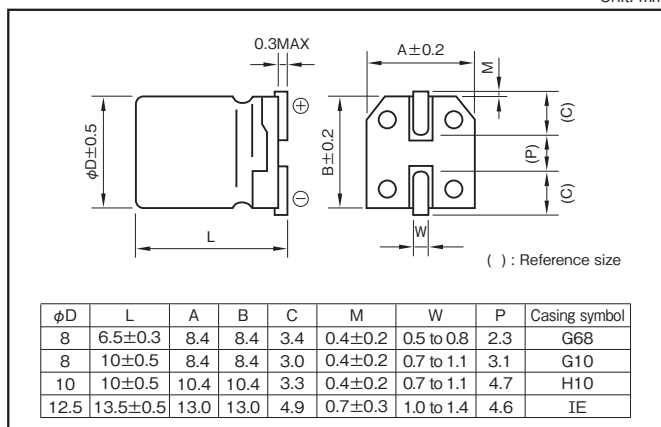

- Soldering conditions are described on page 13.
- Land pattern size are described on page 11.
- The taping specifications are described on page 14.

### Coefficient of Frequency for Rated Ripple Current

Rated voltage (V)	Frequency (Hz)			
	50 · 60	120	1k	10k · 100k
6.3 to 16	0.80	1	1.15	1.25
25 to 35	0.80	1	1.25	1.40
50 to 63	0.80	1	1.35	1.50
100	0.70	1	1.35	1.50

Rated capacitance (μF)	Frequency (Hz)			
	120	1k	10k	100k
100 to 220	1	1.21	1.29	1.43
330 to 1000	1	1.16	1.23	1.25
1500 to 2200	1	1.06	1.11	1.11

### Part numbering system

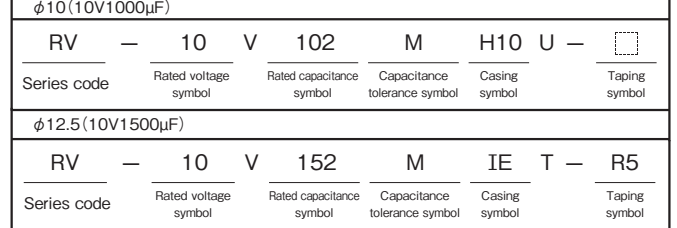

### Standard Ratings

Rated voltage (V)	6.3			10			16			25			35			50			63			100				
	Case φD (mm)	Casing symbol	Rated ripple current (mA rms)	Case φD (mm)	Casing symbol	Rated ripple current (mA rms)	Case φD (mm)	Casing symbol	Rated ripple current (mA rms)	Case φD (mm)	Casing symbol	Rated ripple current (mA rms)	Case φD (mm)	Casing symbol	Rated ripple current (mA rms)	Case φD (mm)	Casing symbol	Rated ripple current (mA rms)	Case φD (mm)	Casing symbol	Rated ripple current (mA rms)	Case φD (mm)	Casing symbol	Rated ripple current (mA rms)		
10	—	—	—	—	—	—	—	—	—	—	—	—	—	—	—	—	—	—	—	—	—	—	—	—		
22	—	—	—	—	—	—	—	—	—	—	—	—	—	—	—	8×6.5	G68	155	8×10	G10	139	10×10	H10	189		
33	—	—	—	—	—	—	—	—	—	—	—	—	—	—	8×6.5	G68	155	8×6.5	G68	155	8×10	G10	139	10×10	H10	189
47	—	—	—	—	—	—	—	—	—	—	—	—	—	—	8×6.5	G68	155	8×6.5	G68	155	8×10	G10	252	10×10	H10	226
68	—	—	—	—	—	—	—	—	—	—	—	—	—	—	—	—	—	—	—	—	—	—	—	—	—	
100	—	—	—	8×6.5	G68	155	8×6.5	G68	155	8×6.5	G68	155	8×10	G10	252	10×10	H10	458	10×10	H10	226	12.5×13.5	IE	242		
220	8×6.5	G68	155	8×6.5	G68	155	8×10	G10	252	8×10	G10	252	10×10	H10	458	—	—	—	—	—	—	—	—	—	—	
330	8×6.5	G68	155	8×10	G10	252	8×10	G10	252	10×10	H10	458	—	—	—	12.5×13.5	IE	451	—	—	—	—	—	—	—	
470	8×10	G10	252	10×10	H10	458	8×10	G10	252	10×10	H10	458	12.5×13.5	IE	460	—	—	—	—	—	—	—	—	—	—	
820	—	—	—	—	—	—	—	—	—	—	—	—	—	—	—	—	—	—	—	—	—	—	—	—	—	
1000	10×10	H10	458	10×10	H10	458	12.5×13.5	IE	521	—	—	—	—	—	—	—	—	—	—	—	—	—	—	—	—	
1500	—	—	—	12.5×13.5	IE	580	—	—	—	—	—	—	—	—	—	—	—	—	—	—	—	—	—	—	—	
2200	12.5×13.5	IE	651	—	—	—	—	—	—	—	—	—	—	—	—	—	—	—	—	—	—	—	—	—	—	

(Note) Rated ripple current : 85°C, 120Hz

### NOTE

Design, Specifications are subject to change without notice.  
Ask factory for technical specifications before purchase and/or use.