

2nd Generation

DESCRIPTION

This family is a 64M bit dynamic RAM organized 8,388,608 x 8-bit configuration with Extended Data Out mode CMOS DRAMs. Extended data out mode is a kind of page mode which is useful for the read operation. The circuit and process design allow this device to achieve high performance and low power dissipation. Optional features are access time(50 or 60ns) and refresh cycle(8K ref. or 4K ref.)and package(SOJ or TSOP-II) and power consumption (Normal or Low power with self refresh). Hyundai's advanced circuit design and process technology allow this device to achieve high bandwidth, low power consumption and high reliability.

FEATURES

- Extended data out operation
- Read-modify-write capability
- Multi-bit parallel test capability
- LVTTTL(3.3V) compatible inputs and outputs
- /CAS-before-/RAS, /RAS-only, Hidden and Self refresh capability
- Max. Active power dissipation
- JEDEC standard pinout
32-pin plastic SOJ/TSOP-II (400mil)
- Single power supply of 3.3 ± 0.3V
- Early write or output enable controlled write
- Fast access time and cycle time

Speed	8K refresh	4K refresh
50	396mW	504mW
60	324mW	432mW

Speed	tRAC	tCAC	tHPC
50	50ns	13ns	20ns
60	60ns	15ns	25ns

- Refresh cycles

Part number	Refresh	Normal	L-part
HY51V64804A ¹⁾	8K	64ms	128ms
HY51V65804A ²⁾	4K		

1) Normal read / write, /RAS only refresh : 8K cycles / 64ms
 /CAS-before-/RAS, Hidden refresh : 4K cycles / 64ms
 2) Normal read / write, /RAS only refresh : 4K cycles / 64ms
 /CAS-before-/RAS, Hidden refresh : 4K cycles / 64ms

ORDERING INFORMATION

Part Name	Refresh	Power	Package
HY51V64804ATC	8K		32Pin SOJ/TSOP-II
HY51V64804ALTC	8K	L-part	32Pin SOJ/TSOP-II
HY51V64804ASLTC	8K	*SL-part	32Pin SOJ/TSOP-II
HY51V65804ATC	4K		32Pin SOJ/TSOP-II
HY51V65804ALTC	4K	L-part	32Pin SOJ/TSOP-II
HY51V65804ASLTC	4K	*SL-part	32Pin SOJ/TSOP-II

*SL : Self refresh with low power.

FUNCTIONAL BLOCK DIAGRAM

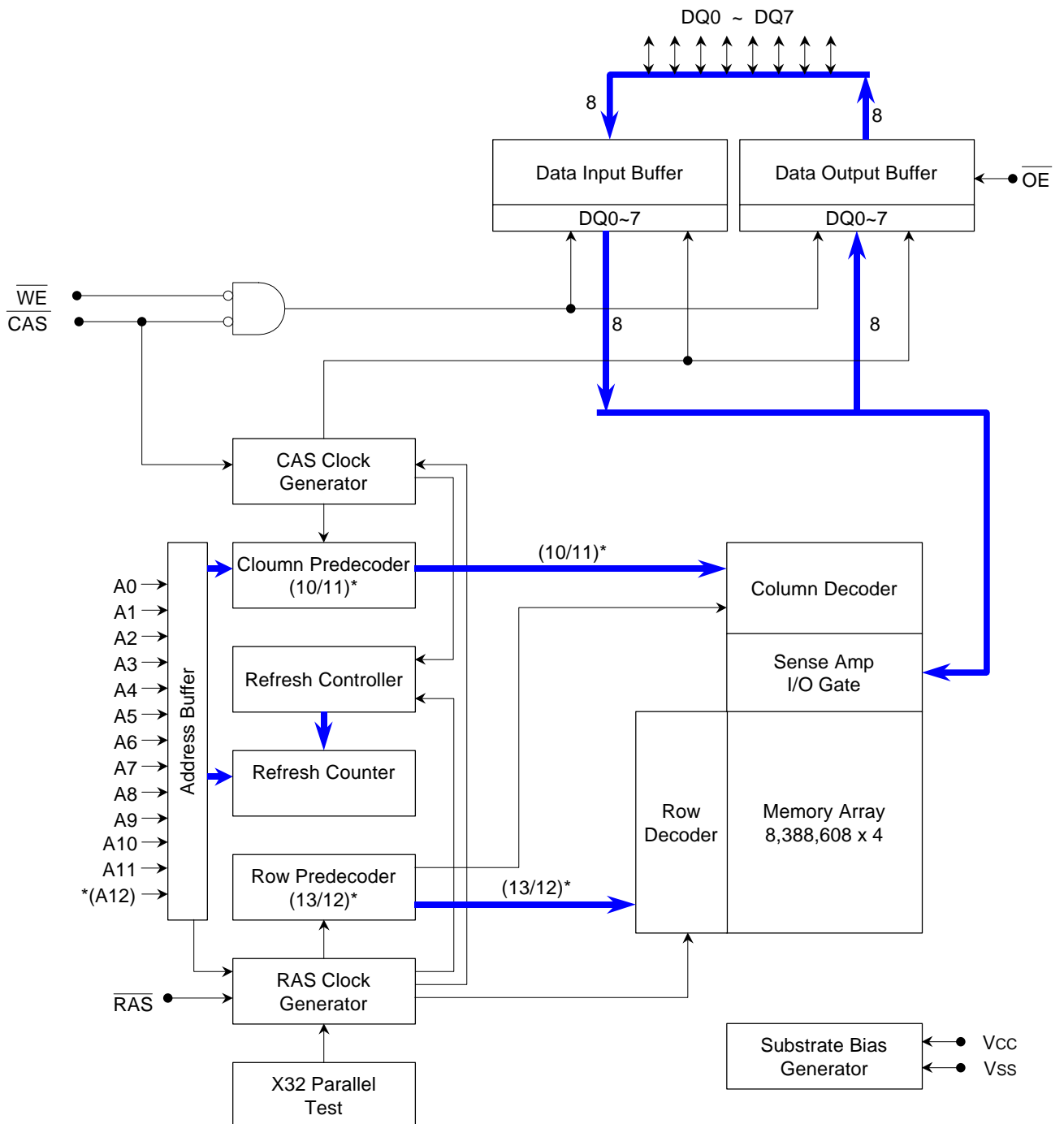

*(A12) for 8K refresh part

(8K Refresh / 4K Refresh)*

PIN CONFIGURATION (Marking Side)

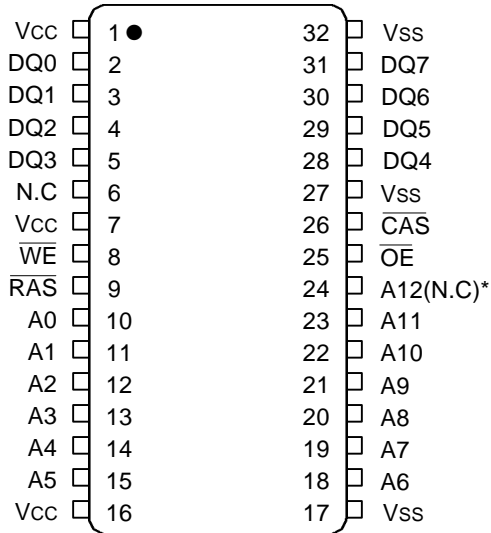

32Pin Plastic SOJ (400mil)

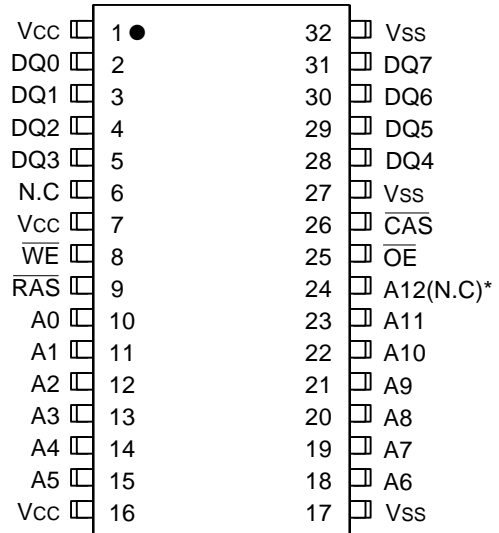

32Pin Plastic TSOP-II (400mil)

A12(N.C)* : For 4K refresh product

PIN DESCRIPTION

Pin Name	Parameter
/RAS	Row Address Strobe
/CAS	Column Address Strobe
/WE	Write Enable
/OE	Output Enable
A0~A12	Address Input (8K Refresh Product)
A0~A11	Address Input (4K Refresh Product)
DQ0~DQ7	Data In/Out
Vcc	Power (3.3V)
Vss	Ground
NC	No Connection

ABSOLUTE MAXIMUM RATING

Symbol	Parameter	Rating	Unit
T _A	Ambient Temperature	0 to 70	°C
T _{STG}	Storage Temperature	-55 to 150	°C
V _{IN} , V _{OUT}	Voltage on Any Pin relative to V _{SS}	-0.5 to 6.0	V
V _{CC}	Voltage on V _{CC} relative to V _{SS}	-0.5 to 4.6	V
I _{OS}	Short Circuit Output Current	50	mA
P _D	Power Dissipation	1	W
T _{SOLDER}	Soldering Temperature • Time	260 • 10	°C • sec

Note : Operation at or above Absolute Maximum Ratings could adversely affect device reliability and cause permanent damage.

RECOMMENDED DC OPERATING CONDITIONS

(T_A = 0°C to 70°C)

Symbol	Parameter	Min	Typ	Max	UNIT
V _{CC}	Power Supply Voltage	3.0	3.3	3.6	V
V _{IH}	Input High Voltage	2.0	-	V _{CC} +0.3 ¹⁾	V
V _{IL}	Input Low Voltage	-0.3 ²⁾	-	0.8	V

Note : All voltages are referenced to V_{SS}.

- 1) 6.0V at pulse width 10ns which is measured at V_{CC}.
- 2) -1.0V at pulse width 10ns which is measured at V_{SS}.

DC AND OPERATING CHARACTERISTICS

Symbol	Parameter	Test condition	Min	Max	Unit
I _{LI}	Input Leakage Current (Any input)	V _{SS} ≤ V _{IN} ≤ V _{CC} + 0.3 All other pins not under test = V _{SS}	-5	5	μA
I _{LO}	Output Leakage Current (Any input)	V _{SS} ≤ V _{OUT} ≤ V _{CC} /RAS&/CAS at V _{IH}	-5	5	μA
V _{OL}	Output Low Voltage	I _{OL} = 2.0mA	-	0.4	V
V _{OH}	Output High Voltage	I _{OL} = -2.0mA	2.4	-	V

DC CHARACTERISTICS

(TA = 0°C to 70°C, VCC = 3.3 ± 0.3V, VSS = 0V, unless otherwise noted.)

Symbol	Parameter	Test condition	Speed	Max. Current		Unit
				8K refresh	4K refresh	
ICC1	Operating Current	/RAS, /CAS Cycling tRC = tRC(min.)	50 60	110 90	140 120	mA
ICC2	LVTTTL Standby Current	/RAS, /CAS ≥ VIH Other inputs ≥ VSS		1	1	mA
ICC3	/RAS-only Refresh Current	/RAS Cycling, /CAS = VIH tRC = tRC(min.)	50 60	110 90	140 120	mA
ICC4	EDO mode Current	/CAS Cycling, /RAS = VIL tHPC = tHPC(min.)	50 60	120 100	130 110	mA
ICC5	CMOS Standby Current	/RAS = /CAS ≥ VCC - 0.2V	L-part	500 300	500 300	μA
ICC6	/CAS-before-/RAS Refresh Current	tRC = tRC(min.)	50 60	110 90	140 120	mA
ICC7	Battery Back-up Current (L-part)	VIH = VCC - 0.2V, VIL = 0.2V /CAS = CBR cycling or 0.2V /OE&/WE = VIH = VCC - 0.2V Address = Don't care DQ0~DQ7 = Open, tRAS ≤ 300ns tRC=31.25μS		550	550	μA
ICC8	Self Refresh Current (L-part)	/RAS&/CAS = 0.2V Other pins are same as ICC7		450	450	μA

Note

1. ICC1, ICC3, ICC4 and ICC6 depend on output loading and cycle rates(tRC and tHPC).
2. Specified values are obtained with output unloaded.
3. ICC is specified as an average current. In ICC1, ICC3, ICC6, address can be changed only once while /RAS=VIL. In ICC4, address can be changed maximum once while /CAS=VIH within one EDO mode cycle time tHPC.

AC CHARACTERISTICS

(TA = 0 °C to 70 °C, VCC = 3.3 ± 0.3V, VSS = 0V, unless otherwise noted.)

#	Symbol	Parameter	50ns		60ns		Unit	Note
			Min	Max	Min	Max		
1	tRC	Random read or write cycle time	84	-	104	-	ns	
2	tRWC	Read-modify-write cycle time	120	-	140	-	ns	
3	tHPC	EDO mode cycle time	20	-	25	-	ns	
4	tHPRWC	EDO mode read-modify-write cycle time	57	-	65	-	ns	
5	tRAC	Access time from /RAS	-	50	-	60	ns	4,5,10,11
6	tCAC	Access time from /CAS	-	13	-	15	ns	4,5,10
7	tAA	Access time from column address	-	25	-	30	ns	4,5,11
8	tCPA	Access time from /CAS precharge	-	30	-	35	ns	4
9	tCLZ	/CAS to output low impedance	0	-	0	-	ns	3
10	tCEZ	Output buffer turn-off delay from /CAS	0	10	0	15	ns	
11	tOLZ	/OE to output in low impedance	0	-	0	-	ns	
12	tT	Transition time(rise and fall)	2	50	2	50	ns	4
13	tRP	/RAS precharge time	30	-	40	-	ns	
14	tRAS	/RAS pulse width	50	10K	60	10K	ns	
15	tRASP	/RAS pulse width(EDO mode)	50	100K	60	100K	ns	
16	tRSH	/RAS hold time	13	-	15	-	ns	
17	tCSH	/CAS hold time	40	-	45	-	ns	
18	tCAS	/CAS pulse width	8	10K	10	10K	ns	
19	tRCD	/RAS to /CAS delay time	15	37	20	45	ns	10
20	tRAD	/RAS to column address delay time	13	25	15	30	ns	11
21	tCRP	/CAS to /RAS precharge time	5	-	5	-	ns	
22	tCP	/CAS precharge time	8	-	10	-	ns	15
23	tASR	Row address set-up time	0	-	0	-	ns	
24	tRAH	Row address hold time	8	-	10	-	ns	
25	tASC	Column address set-up time	0	-	0	-	ns	14
26	tCAH	Column address hold time	8	-	10	-	ns	14
27	tRAL	Column address to /RAS lead time	25	-	30	-	ns	
28	tRCS	Read command set-up time	0	-	0	-	ns	
29	tRCH	Read command hold time referenced to /CAS	0	-	0	-	ns	7
30	tRRH	Read command hold time referenced to /RAS	0	-	0	-	ns	7
31	tWCH	Write command hold time	10	-	10	-	ns	

AC CHARACTERISTICS

Continued

#	Symbol	Parameter	50ns		60ns		Unit	Note
			Min	Max	Min	Max		
32	tWP	Write command pulse width	8	-	10	-	ns	
33	tRWL	Write command to /RAS lead time	15	-	15	-	ns	
34	tCWL	Write command to /CAS lead time	8	-	10	-	ns	17
35	tDS	Data-in set-up time	0	-	0	-	ns	8,20
36	tDH	Data-in hold time	10	-	10	-	ns	8,20
37	tREF	Refresh period(4096 cycles)	-	64	-	64	ms	12,13
		Refresh period(8192 cycles)	-	64	-	64	ms	12,13
		Refresh period(L-part)	-	128	-	128	ms	12,13
38	tWCS	Write command set-up time	0	-	0	-	ns	9
39	tCWD	/CAS to /WE delay time	34	-	36	-	ns	9,16
40	tRWD	/RAS to /WE delay time	70	-	80	-	ns	9
41	tAWD	Column address to /WE delay time	45	-	50	-	ns	9
42	tCSR	/CAS set-up time(CBR cycle)	5	-	5	-	ns	18
43	tCHR	/CAS hold time(CBR cycle)	10	-	10	-	ns	19
44	tRPC	/RAS to /CAS precharge time	5	-	5	-	ns	
45	tCPT	/CAS precharge time(CBR counter test)	25	-	30	-	ns	
46	tROH	/RAS hold time referenced to /OE	5	-	5	-	ns	
47	tOEA	/OE access time	-	13	-	15	ns	
48	tOED	/OE to data delay	13	-	15	-	ns	
49	tOEZ	Output buffer turn-off delay time from /OE	0	10	0	15	ns	6
50	tOEH	/OE command hold time	13	-	15	-	ns	
51	tCPWD	/WE delay time from /CAS precharge	45	-	54	-	ns	6
52	tRHCP	/RAS hold time from /CAS precharge	30	-	35	-	ns	
53	tWRP	/WE to /RAS precharge time(CBR cycle)	10	-	10	-	ns	
54	tWRH	/WE to /RAS hold time(CBR cycle)	10	-	10	-	ns	
55	tWTS	Write command set-up time(test mode in)	10	-	10	-	ns	
56	tWTH	Write command hold time(test mode in)	10	-	10	-	ns	
57	tRASS	/RAS pulse width(self refresh)	100K	-	100K	-	ns	
58	tRPS	/RAS precharge time(self refresh)	100	-	110	-	ns	
59	tCHS	/CAS hold time(self refresh)	-50	-	-50	-	ns	
60	tDOH	Output data hold time	5	-	5	-	ns	

AC CHARACTERISTICS

Continued

#	Symbol	Parameter	50ns		60ns		Unit	Note
			Min	Max	Min	Max		
61	tREZ	Output buffer turn-off delay from /RAS	0	10	0	15	ns	6
62	tWEZ	Output buffer turn-off delay from /WE	0	10	0	15	ns	6
63	tWED	/WE to data delay time	15	-	15	-	ns	
64	tOEP	/OE precharge time	5	-	5	-	ns	
65	tWPE	/WE pulse width(EDO cycle)	5	-	5	-	ns	
66	tOCH	/OE to /CAS hold time	5	-	5	-	ns	
67	tCHO	/CAS hold time to /OE	5	-	5	-	ns	

TEST MODE

#	Symbol	Parameter	50ns		60ns		Unit	Note
			Min	Max	Min	Max		
1	tRC	Random read or write cycle time	89	-	109	-	ns	
2	tRWC	Read-modify-write cycle time	125	-	145	-	ns	
3	tHPC	EDO mode cycle time	25	-	30	-	ns	
4	tHPRWC	EDO mode read-modify-write cycle time	62	-	70	-	ns	
5	tRAC	Access time from /RAS	-	55	-	65	ns	4,5,10,11
6	tCAC	Access time from /CAS	-	18	-	20	ns	4,5,10
7	tAA	Access time from column address	-	30	-	35	ns	4,5,11
8	tCPA	Access time from /CAS precharge	-	35	-	40	ns	4
14	tRAS	/RAS pulse width	55	10K	65	10K	ns	
15	tRASP	/RAS pulse width(EDO mode)	55	100K	65	100K	ns	
16	tRSH	/RAS hold time	20	-	20	-	ns	4
17	tCSH	/CAS hold time	45	-	55	-	ns	
18	tCAS	/CAS pulse width	13	10K	15	10K	ns	
27	tRAL	Column address to /RAS lead time	30	-	35	-	ns	
39	tCWD	/CAS to /WE delay time	39	-	41	-	ns	16
40	tRWD	/RAS to /WE delay time	75	-	85	-	ns	
41	tAWD	Column address to /WE delay time	50	-	55	-	ns	9
47	tOEA	/OE access time	-	18	-	20	ns	
48	tOED	/OE to data delay	18	-	20	-	ns	
50	tOEH	/OE command hold time	18	-	20	-	ns	
51	tCPWD	/WE delay time from /CAS precharge	50	-	59	-	ns	9

NOTE

1. An initial pause of 200 μ s is required after power-up followed by 8 /RAS-only refresh cycles before proper device operation is achieved. In case of using internal refresh counter, a minimum of 8 /CAS- before-/RAS initialization cycles instead of 8 /RAS-only refresh cycles are required. The device should be carefully initialized to be prevented from being entered into multi bit parallel test mode during initialization.
2. If /RAS=Vss during power-up, the HY51V64804A, HY51V65804A could begin an active cycle. This condition results in higher current than necessary current which is demanded from the power supply during power-up.
3. It is recommended that /RAS and /CAS track with Vcc during power-up or be held at a valid VIH in order to minimize the power-up current.
4. VIH(min.) and VIL(max.) are reference levels for measuring timing of input signals. Transition times are measured between VIH(min.) and VIL(max.), and are assumed to be 2ns for all inputs.
5. Measured at VOH=2.0V and VOL=0.8V with a load equivalent to 1TTL loads and 100pF.
6. tWEZ, tREZ, tCEZ and tOEZ define the time at which the output achieves the open circuit condition and is not referenced to output voltage levels.
7. Either trCH or trRH must be satisfied for a read cycle.
8. These parameters are referenced to /CAS leading edge in early write cycles and to /WE leading edge in read-modify-write cycles and late write cycle.
9. twCS, trWD, tcWD, tAWD and tCPWD are not restrictive operating parameters. They are included in the data sheet as electrical characteristics only. If twCS \geq twCS(min.), the cycle is an early write cycle and data out pin will remain open circuit (high impedance) through the entire cycle. If trWD \geq trWD(min.), tcWD \geq tcWD(min.), tAWD \geq tAWD(min), and tCPWD \geq tCPWD(min.), the cycle is a read-modify-write cycle and data out will contain data read from the selected cell. If neither of the above sets of conditions is satisfied, the condition of the data out (at access time) is indeterminate.
10. Operation within the tRCD(max.) limit ensures that tRAC(max.) can be met. tRCD(max.) is specified as a reference point only. If tRCD is greater than the specified tRCD(max.) limit, then access time is controlled by tCAC.
11. Operation within the tRAD(max.) limit ensures that tRAC(max.) can be met. tRAD(max.) is specified as a reference point only. If tRAD is greater than the specified tRAD(max.) limit, then access time is controlled by tAA.
12. tREF(max)=128ms is applied to L-parts.
13. A burst of 4096(4K refresh part) /RAS-only refresh cycles must be executed within 64ms (128ms for L-parts) after exiting self refresh. A burst of 8192(8K refresh part) /RAS-only refresh cycles must be executed within 64ms (128ms for L-parts) after exiting self refresh. (CBR refresh & Hidden refresh : 4K cycle/64ms)

CAPACITANCE

(TA = 0°C to 70°C , VCC = 3.3 \pm 0.3V, VSS = 0V, f = 1MHz, unless otherwise noted.)

Symbol	Parameter	Typ.	Max	Unit
CIN1	Input Capacitance (A0~A12)	-	5	pF
CIN2	Input Capacitance (/RAS, /CAS, /WE, /OE)	-	7	pF
CDQ	Data Input / Output Capacitance (DQ0~DQ7)	-	7	pF