

TENTATIVE

TOSHIBA INFRARED LED GaAlAs INFRARED EMITTER

TLN221

INFRARED LED FOR SPACE-OPTICAL-TRANSMISSION

Unit in mm

- High radiant power : $P_o = 18\text{mW}$ (TYP.) at $I_F = 50\text{mA}$
- Wide radiant pattern : $\theta_{\frac{1}{2}} = \pm 21^\circ$ (TYP.)
- High speed response : $t_r, t_f = 30\text{ns}$ (TYP.)
- A light source for remote control.
- Wireless AV-signal transmission purpose.
- High speed data transmission purpose.

MAXIMUM RATINGS ($T_a = 25^\circ\text{C}$)

CHARACTERISTIC	SYMBOL	RATING	UNIT
Forward Current	I_F	100	mA
Pulse Forward Current	I_{FP}	1000 (Note:1)	mA
Power Dissipation	P_D	220	mW
Reverse Voltage	V_R	4	V
Operating temperature Range	T_{opr}	-25~85	$^\circ\text{C}$
Storage Temperature Range	T_{stg}	-30~100	$^\circ\text{C}$
Soldering Temperature (5s)	T_{sol}	260	$^\circ\text{C}$

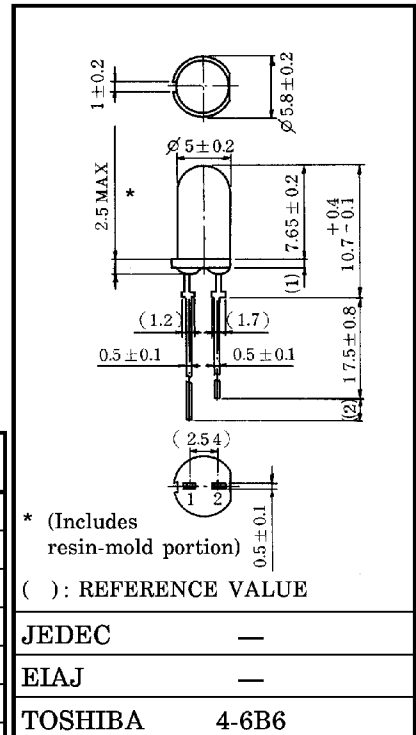

(Note : 1) Frequency = 100kHz, duty = 1%

PIN CONNECTION

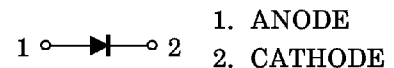

OPTO-ELECTRICAL CHARACTERISTICS ($T_a = 25^\circ\text{C}$)

CHARACTERISTIC	SYMBOL	TEST CONDITION	MIN.	TYP.	MAX.	UNIT
Forward Voltage	V_F	$I_F = 100\text{mA}$	—	1.8	2.2	V
Reverse Current	I_R	$V_R = 4\text{V}$	—	—	60	μA
Radiant Power	P_O	$I_F = 50\text{mA}$	14	18	—	mW
Radiant Intensity	I_E	$I_F = 50\text{mA}$	—	30	—	mW / sr
Rise Time, Fall Time	t_r, t_f	$I_{FP} = 100\text{mA}, P_W = 100\text{ns}$	—	30	—	ns
Cut-off Frequency (Note:2)	f_c	$I_F = 50\text{mA}_{DC} + 5\text{mA}_{P-P}$	10	15	—	MHz
Capacitance	C_T	$V_R = 0, f = 1\text{MHz}$	—	110	—	pF
Peak Emission Wavelength	λ_P	$I_F = 50\text{mA}$	830	870	900	nm
Spectral Line Half Width	$\Delta\lambda$	$I_F = 50\text{mA}$	—	50	—	nm
Half Value Angle	$\theta_{\frac{1}{2}}$	$I_F = 50\text{mA}$	—	± 21	—	$^\circ$

(Note : 2) Frequency when modulation light power decreases by 3dB from 1MHz.

961001EAC2

● TOSHIBA is continually working to improve the quality and the reliability of its products. Nevertheless, semiconductor devices in general can malfunction or fail due to their inherent electrical sensitivity and vulnerability to physical stress. It is the responsibility of the buyer, when utilizing TOSHIBA products, to observe standards of safety, and to avoid situations in which a malfunction or failure of a TOSHIBA product could cause loss of human life, bodily injury or damage to property. In developing your designs, please ensure that TOSHIBA products are used within specified operating ranges as set forth in the most recent products specifications. Also, please keep in mind the precautions and conditions set forth in the TOSHIBA Semiconductor Reliability Handbook.

PRECAUTION

Please be careful of the followings.

1. Soldering shall be performed at the top portion from the lead stopper.
2. When the lead is formed, the lead shall be formed at the top portion of the stopper without leaving forming stress to the body of the device.
Soldering shall be performed after lead forming.

961001EAC2'

- Gallium arsenide (GaAs) is a substance used in the products described in this document. GaAs dust and fumes are toxic. Do not break, cut or pulverize the product, or use chemicals to dissolve them. When disposing of the products, follow the appropriate regulations. Do not dispose of the products with other industrial waste or with domestic garbage.
- The information contained herein is presented only as a guide for the applications of our products. No responsibility is assumed by TOSHIBA CORPORATION for any infringements of intellectual property or other rights of the third parties which may result from its use. No license is granted by implication or otherwise under any intellectual property or other rights of TOSHIBA CORPORATION or others.
- The information contained herein is subject to change without notice.

