

Helping Customers Innovate, Improve & Grow



Features

- Reflow Process Compatible Optional
- Surface Mount package Optional
- SC_CUT Crystal
- Low Profile Compact Package
- standard frequency: 10 & 20 MHz

Applications

- Base stations
- Test equipment
- Synthesizers
- Military communication equipment
- Digital Switching

Performance Specifications

Frequency Stabilities ¹ (SC-Cut Crystal - 10 & 20 MHz)					
Parameter	Min	Typical	Max	Units	Condition
vs. operating temperature range (referenced to +25°C)	-5		+5	ppb	-20 to +70°C
	-5		+5	ppb	-20 to +70°C
	-10		+10	ppb	-40 to +85°C
Initial tolerance	-0.2		+0.2	ppm	at time of shipment, nominal EFC
vs. supply voltage change	-2		+2	ppb	$V_s \pm 5\%$ static
vs. load change	-2		+2	ppb	Load $\pm 5\%$ static
vs. aging / day	-0.5		+0.5	ppb	≤ 10 Mhz after 30 days of operation
vs. aging / day	-1		+1	ppb	> 10 Mhz after 30 days of operation
vs. aging / year	-60		+60	ppb	≤ 10 Mhz after 30 days of operation
vs. aging / year	-100		+100	ppb	> 10 Mhz after 30 days of operation
holdover					
start up time					
Warm-up time			5	minutes	to ± 100 ppb of final frequency (1 hour reading) @ +25°C

Performance Specifications

Supply Voltage (Vs)						
Parameter	Min	Typical	Max	Units	Condition	
Supply voltage (standard)	3.135	3.3	3.465	VDC		
	4.75	5.0	5.25	VDC		
Power consumption			3.0	Watts	during warm-up	
			1.0	Watts	steady state @ +25°C	
RF Output						
Signal [standard]	HCMOS					
Load		15		pF		
Signal Level (Vol)			0.4	VDC	with Vs=3.3V and 15pF Load	
Signal Level (Vol)			0.5		with Vs=5.0V & 12V and 15pF Load	
Signal Level (Voh)	2.4			VDC	with Vs=3.3V and 15pF Load	
Signal Level (Voh)	3.5				with Vs=5.0V & 12V and 15pF Load	
rise time			5	ns		
fall time			5	ns		
Duty Cycle	45		55	%	@ (Voh-Vol)/2	
Frequency Tuning (EFC)						
Tuning Range	Fixed OCXO; No adjust				Opti- on ^s	
	±1.0		±2.5	ppm		with SC cut crystal
Linearity	10%					
Tuning Slope	Positive					
Control Voltage Range	0.0	1.4	2.8	VDC	with Vs=3.3V	
	0.0	2.0	4.0		with Vs=5.0V	
Reference Voltage Output (Vref)						
Reference Voltage	2.75	2.8	2.85	VDC	with Vs = 3.3 VDC	
	3.92	4.0	4.08	VDC	with Vs = 5.0 VDC	
Additional Parameters						
Phase Noise ³			- 80 -110 -135 -140 -145	dBc/Hz dBc/Hz dBc/Hz dBc/Hz dBc/Hz	1 Hz 10 Hz 100 Hz 1 kHz 10 kHz	@ 10MHz with SC Cut
Phase Noise ³		90 -120 -140 -148 -152	-80 -110 -135 -145 -145	dBc/Hz dBc/Hz dBc/Hz dBc/Hz dBc/Hz	1 Hz 10 Hz 100 Hz 1 kHz 10 kHz	@ 20MHz with SC Cut
Weight			14	g		
Processing & Packing	Handling & Processing Note					

Absolute Maximum Ratings					
supply voltage (Vs)			6.5	V	with Vs=3.3 & 5.0VDC
Output Load			50	pF	
Operable Temperature Range	-45		+85	°C	
Storage Temperature Range	-45		+85	°C	

Outline Drawing / Enclosure

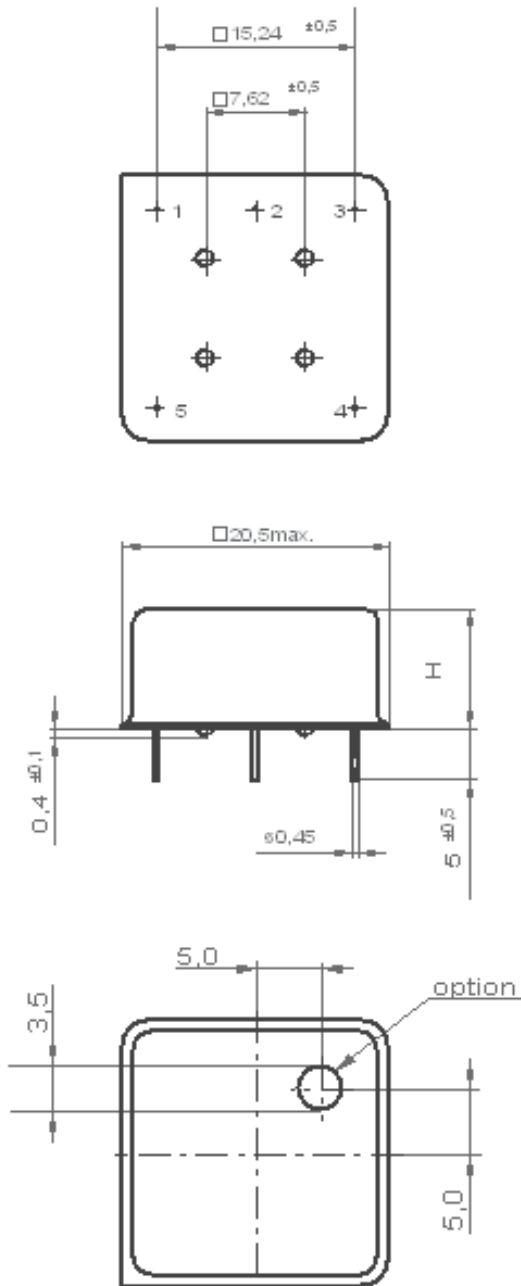

OX-300	
Height "H"	Pin Length "L"
10.0	4.5 min.

Pin Connections	
1	Supply Voltage Input (VS)
2	RF Output
3	Ground (Case)
4	Electronic Frequency Control Input (EFC)
5	N.C or Reference Voltage Option (must remain un connected)

Dimensions in mm

Standard Shipping Method (OX-300)

Enclosure Type	Method	colloums	rows	Quantity per Tray
Typ OX-300	Tray	10	5	50

Recommended Reflow Profile

IPC/JEDEC J-STD-020 (latest revision)

Additional Information:

This SMD oscillator has been designed for pick and place reflow soldering.

SMD oscillators must be on the top side of the PCB during the reflow process.

Additional Environmental Conditions

Parameter	Description
Rapid temperature changes	MIL-883-1010 Cond B 1000 cycles -55/125C
Vibration	MIL-STD-883 Meth 2007 Cond A 20G 20-2000Hz 4x in each 3axis 4 min
Shock	Mech.Shock MIL-STD-202 Meth 213 Cond.C 100G 6ms 6 shocks in each direction
Solderability	J_STD_002C Cond A, Through hole device/ Cond. B, SMD 255C (diving time 50,5sec.) Dip+Look with 8h damp pre-treatment: solder wetting >95%
Solvent resistance	MIL-STD-883 Meth 2015 Solv. 1,3,4
ESD	HBM JESD22-A114-F Class 1C 10* 1000V
Moisture Sensit.	Level 1 JESD22-A113-B
RoHS compliance	100% RoHS 6 compliant
Washable	washable device

Note: All temperatures refer to topside of the package, measured on the package body surface.

Ordering Information

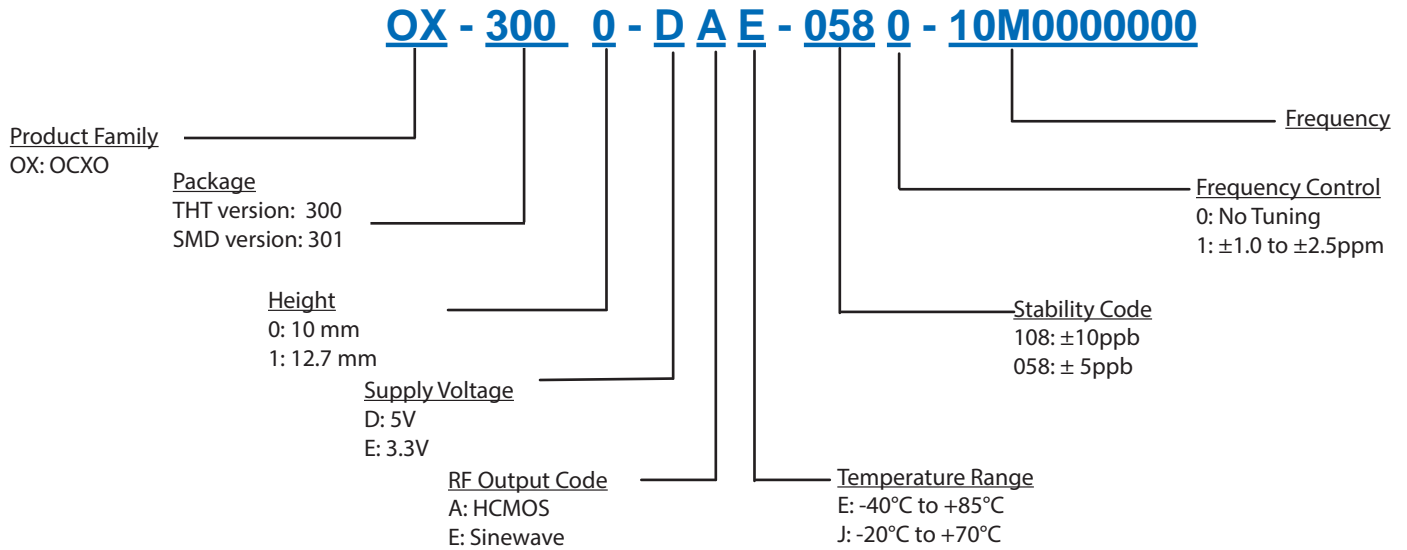

Notes:

1. Contact factory for improved stabilities or additional product options. Not all options and codes are available at all frequencies.
2. Unless other stated all values are valid after warm-up time and refer to typical conditions for supply voltage, frequency control voltage, load, temperature (25°C).
3. Phase noise degrades with increasing output frequency.
4. Subject to technical modification.
5. Contact factory for availability.

For Additional Information, Please Contact

USA:

Vectron International
267 Lowell Road
Suite 102
Hudson, NH 03051
Tel: 1.888.328.7661
Fax: 1.888.329.8328

Europe:

Vectron International
Landstrasse, D-74924
Neckarbischofsheim, Germany
Tel: +49 (0) 7268.801.100
Fax: +49 (0) 7268.801.282

Asia:

Vectron International
68 Yin Cheng Road(C), 22nd Floor
One LuJiaZui
Pudong, Shanghai 200120, China
Tel: +86 21 6194 6886
Fax: +86 21 6194 6699

Disclaimer

Vectron International reserves the right to make changes to the product(s) and or information contained herein without notice. No liability is assumed as a result of their use or application. No rights under any patent accompany the sale of any such product(s) or information.

Rev: 18 Feb 2014