

1933 F/R/W Coaxial DFB Laser Diode

1310 nm, Wide Bandwidth 5 MHz – 4000 MHz



Applications

- Video Signal Distribution in HFC and FTTx Nodes
- Signal Distribution in L-Band and Wireless Remoting Links
- High Linearity, Low Power Fiber Links

Features

- Linear DFB Laser Design
- Output Power Up to 10 dBm Available
- Bandwidth > 4000 MHz
- RoHS Compliance
- Optical Isolator
- Low Power Consumption
- Monitor Photodiode

EMCORE's Model 1933 DFB lasers offer a low cost solution for linear fiber optic links. These components can be cooled with external thermo-electric coolers for high stability, or run without TEC's to reduce power consumption. The DFB laser builds upon Ortel's long history of high performance, leading edge designs in CATV, wireless, and high speed digital applications. The laser diode devices are packaged in a compact hermetic assembly together with monitor photodiode and isolator, for flexible integration into various transmitter configurations.

Performance Highlights

Parameters	Min	Typical	Max	Units
Operating Case Temperature Range	-40	-	85	°C
Optical Output Power ⁽¹⁾	3	-	5.9	dBm
Frequency Range	5	-	4000	MHz
Carrier-to-Noise Ratio (79 channels) ⁽¹⁾	51	-	-	dB
Composite Second Order (79 channels) ⁽¹⁾				dBc
Composite Triple Beat (79 channels) ⁽¹⁾				dBc
Center Wavelength	1300	-	1320	nm
Optical Return Loss ⁽¹⁾	35	-	-	dB
Side Mode Suppression Ratio, CW ⁽¹⁾	30	-	-	dB

1. Performance at Tcase = 25°C



1933 F/R/W Coaxial DFB Laser Diode

1310 nm, Wide Bandwidth 5 MHz – 4000 MHz



DATASHEET | MAY 2012

FIBER OPTICS

Absolute Maximum Ratings¹

Stresses in excess of the absolute maximum ratings can cause permanent damage to the device. These are absolute stress ratings only. Functional operation of the device is not implied at these or any other conditions in excess of those given in the operational sections of the data sheet. Exposure to absolute maximum ratings for extended periods can adversely affect device reliability.

Parameters	Symbol	Condition/Notes	Min	Max	Unit
Storage Temperature	T _{STG}	Non-Operating	-40	85	°C
Operating Case Temperature	T _{OP}	Continuous	-40	85	°C
Laser Diode Forward Current	I _{OP}	CW	-	150	mA
Laser Diode Reverse Voltage	V _R	Continuous	-	1.0	V
Photodiode Forward Current	I _{MPD}	Continuous	-	2	mA
Photodiode Reverse Voltage	V _{MPD,R}	Continuous	-	10	V
Average RF Input Power	PIN	60 Seconds	-	62	dBmV
Lead Soldering Temperature/Time	-	-	-	260/10	°C/sec
Relative Humidity	RH	Continuous	-	85	%
ESD	-	Human Body Model	-500	+500	V

1. Absolute maximum data are limited to system design only; proper device performance is not guaranteed over rating listed above. Operation beyond these maximum conditions may degrade device performance, lead to device failure, shorter lifetime, and will invalidate the device warranty.

Electrical/Optical Characteristics

Parameters	Symbol	Conditions/Notes	Min	Typ	Max	Unit
Optical Output Power	P _O	1933R opt model: 3 – 6dBm	3	-	4.9	dBm
		1933W opt model: 3 – 10dBm	5	-	5.9	
			6	-	8.9	
		1933F opt model: 3 – 10dBm	9	-	9.9	
			10	-	11.9	
Threshold Current	I _{TH}	T _{case} = 25°C	-	8	15	mA
		T _{case} = 45°C	-	13	20	
Laser Bias Current	I _{OP}		-	-	80	mA
Forward Voltage	V _F	I _{op}	-	1.17	1.8	V
Slope Efficiency	SE	T _{case} = 25°C, I _{op}	0.07	-	0.3	mW/mA
Thermal Slope Efficiency	TSE	SE(T _c)/SE(25°C) T _{case} = -20°C to 85°C	0.4	-	1.2	-
Laser Input Impedance	Z	-	2	4	8	Ω
MPD Current	I _{MPD}	V _{MPD} = 5V, I _{op}	200	-	2000	μA
MPD Dark Current	I _D	V _{MPD} = 5V, I _{op} = 0 T _{case} = 25°C	-	-	50	nA
Center Wavelength	λ _c	I _{op}	1300	-	1320	nm
Relative Intensity Noise	RIN	CW, I _{op} , T _{case} = 25°C 5 MHz - 1002 MHz	-	-	-150	dB/Hz

1933 F/R/W Coaxial DFB Laser Diode

1310 nm, Wide Bandwidth 5 MHz – 4000 MHz



DATASHEET | MAY 2012

FIBER OPTICS

Electrical/Optical Characteristics (continued)

Parameters	Symbol	Conditions/Notes	Min	Typ	Max	Unit
Tracking Error	ΔPf	$I_{MON} = \text{const}$ $ER = 10\log(P_O/2.0)$ [dB]	-1	-	+1	dB
Optical Isolation, $T_{case} = 25^\circ\text{C}$	ISO	Double Isolator	45	-	-	dB
Spectral Width (-20 dB)	$\Delta\lambda$	I_{op}	-	0.1	1.0	nm
Side Mode Suppression Ratio	SMSR	I_{op}	30	45	-	dB
Optical Return Loss	ORL	$T_{case} = 25^\circ\text{C}$	35	-	-	dB

1. Referenced to base of TO header.

Forward Path RF Characteristics

1933F Performance Parameter	Symbol	Conditions/Notes	Min	Typ	Max	Unit
Frequency Response Flatness ¹	$ S_{21} $	5 MHz - 1002 MHz	-	-	1	dB _{p-p}
Response Up-tilt ¹		5 MHz - 1002 MHz	-1		3	dB
Carrier-to-Noise Ratio ^{2,3,4}	CNR	I_{op}	51	-	-	dB
Composite Second Order ^{2,3,4}	Standard Linearity	I_{op} $T_{case} = 25^\circ\text{C}$	-	-	-57	dBc
	Enhanced Linearity					
Composite Triple Beat ^{2,3,4}	Standard Linearity	I_{op} $T_{case} = 25^\circ\text{C}$	-	-	-65	dBc
	Enhanced Linearity					

- I_{op} , $T_{case} = 25^\circ\text{C}$. Test with the laser Input pin matched to a 50 Ω system.
- 3.7% OMI, 79 NTSC unmodulated carriers (50 MHz to 550 MHz). 10 km fiber.
- Received power = 0 dBm.
- I_{op} , $T_{case} = 25^\circ\text{C}$. Test with the laser Input pin matched to a 75 Ω system.

Return Path RF Characteristics

1933R Performance Parameters	Symbol	Conditions/Notes	Min	Typ	Max	Unit
Frequency Response Flatness ¹	$ S_{21} $	5 MHz - 200 MHz	-	-	1	dB _{p-p}
Second Order Distortion ² Standard Linearity Enhanced Linearity	DSO	$P_F = 3$ dBm, OMI = 10% each 2-tone test: f1=7MHz, f2=56MHz 20 km of fiber (7.5 dB total loss with connector) f1 + f2	-	-	-52	dBc
Third Order Distortion ² Standard Linearity Enhanced Linearity	DTB	$P_F = 3$ dBm, OMI = 10% each 2-tone test: f1=7MHz, f2=56MHz 20 km of fiber (7.5 dB total loss with connector) 2f2-f1	-	-	-63	dBc

- I_{op} , $T_{case} = 25^\circ\text{C}$. Test with the laser Input pin matched to a 50 Ω system.
- I_{op} , $T_{case} = 25^\circ\text{C}$. Test with laser input pin matched to a 75 Ω system.

1933 F/R/W Coaxial DFB Laser Diode

1310 nm, Wide Bandwidth 5 MHz – 4000 MHz

Wide Bandwidth Path RF Characteristics

1933W Performance Parameters	Symbol	Conditions/Notes	Min	Typ	Max	Unit
Frequency Response Flatness ¹	S ₂₁	900 MHz – 4000 MHz	-	-	4	dB _{p-p}
Input Third Order Intercept ²	IIP3	Standard Linearity, I _{bb}	30	-	-	dBm
1dB Compression Point ³	P _{1dB}	I _{bb}	16	-	-	dBm
Relative Intensity Noise ⁴ (BW = 50MHz – 2GHz)	RIN	T _c = 25 °C, I _{op} Constant opt power	-150	-	-	dB/Hz
		T _c = -20 °C to +85 °C, I _{op} Constant opt power	-145	-	-	dB/Hz

1. I_{op}, T_{case} = 25°C. Test with the laser Input pin matched to a 50Ω system.
2. IIP3 is measured at I_{bb} where I_{bb} is the bias point at which simultaneously the laser at its best linearity and the optical power is within specification. Test Frequency F1 = 2700MHz, F2 = 2703MHz, RF in = 0dBm/frequency. 0km fiber.
3. Test at 2700MHz. 0km fiber.
4. Guaranteed by design. Not to be tested in production

Package Outline Drawing (dimensions are in mm)

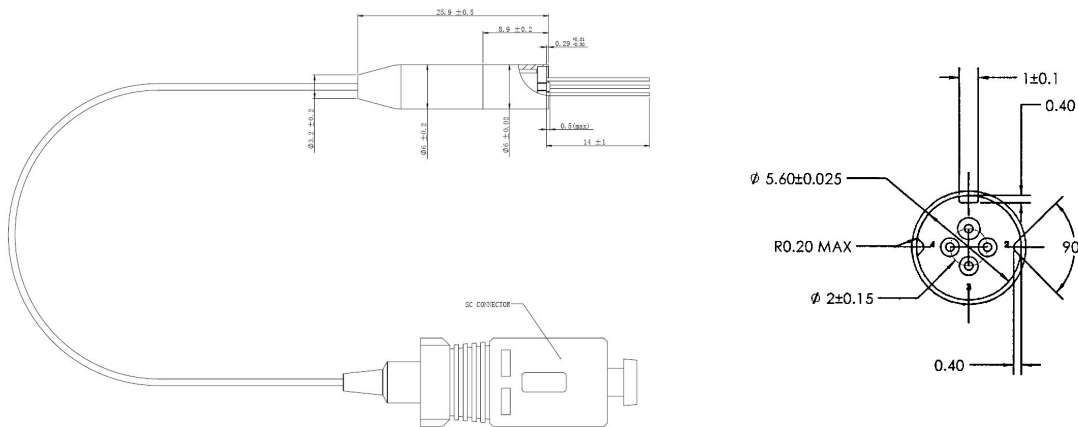

Mounting Bracket

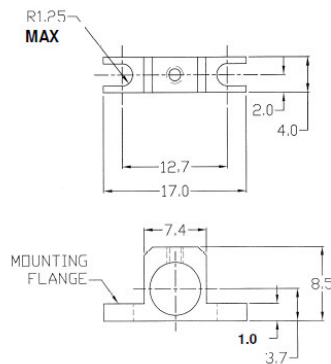

NOTES:

1. UNIT: mm
2. TOLERANCE: ±0.1mm UNLESS OTHERWISE SPECIFIED

1933 F/R/W Coaxial DFB Laser Diode

1310 nm, Wide Bandwidth 5 MHz – 4000 MHz

Reliability/Quality

Designed to meet qualification requirements of Telcordia™ (Bellcore) GR-468-CORE.

Schematic and Pinout

Schematic and Pinout A

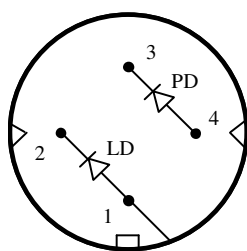

Pinout A

Bottom View

Pin Definitions for Pinout A

Pin	Description
1	LD Anode, Case Ground
2	LD Cathode
3	PD Cathode
4	PD Anode

Schematic and Pinout C

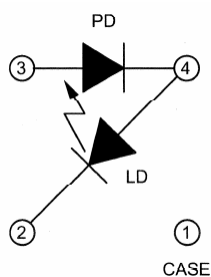

Bottom View

Pin Definitions for Pinout C

Pin	Description
1	Case
2	LD Cathode
3	PD Anode
4	LD Anode, PD Cathode

1933 F/R/W Coaxial DFB Laser Diode

1310 nm, Wide Bandwidth 5 MHz – 4000 MHz

Laser Safety

This product meets the appropriate standard in Title 21 of the Code of Federal Regulations (CFR). FDA/CDRH Class IIIb laser product. This device has been classified with the FDA/CDRH under accession number 0220191.

Wavelength = 1.3 μ m.

Maximum power = 50 mW.

Because of size constraints, laser safety labeling (including an FDA class IIIb label) is not affixed to the module, but attached to the outside of the shipping carton. Product is not shipped with power supply.

Caution: Use of controls, adjustments and procedures other than those specified herein may result in hazardous laser radiation exposure.

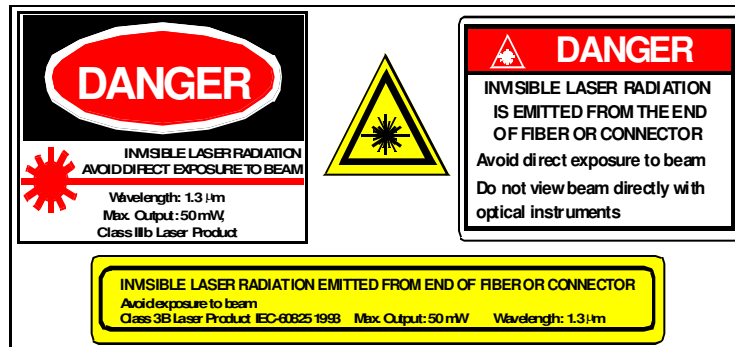

1933 F/R/W Coaxial DFB Laser Diode

1310 nm, Wide Bandwidth 5 MHz – 4000 MHz



DATASHEET | MAY 2012

FIBER OPTICS

Ordering Code Definitions

1933F - a - ww - x - yy - zz - v

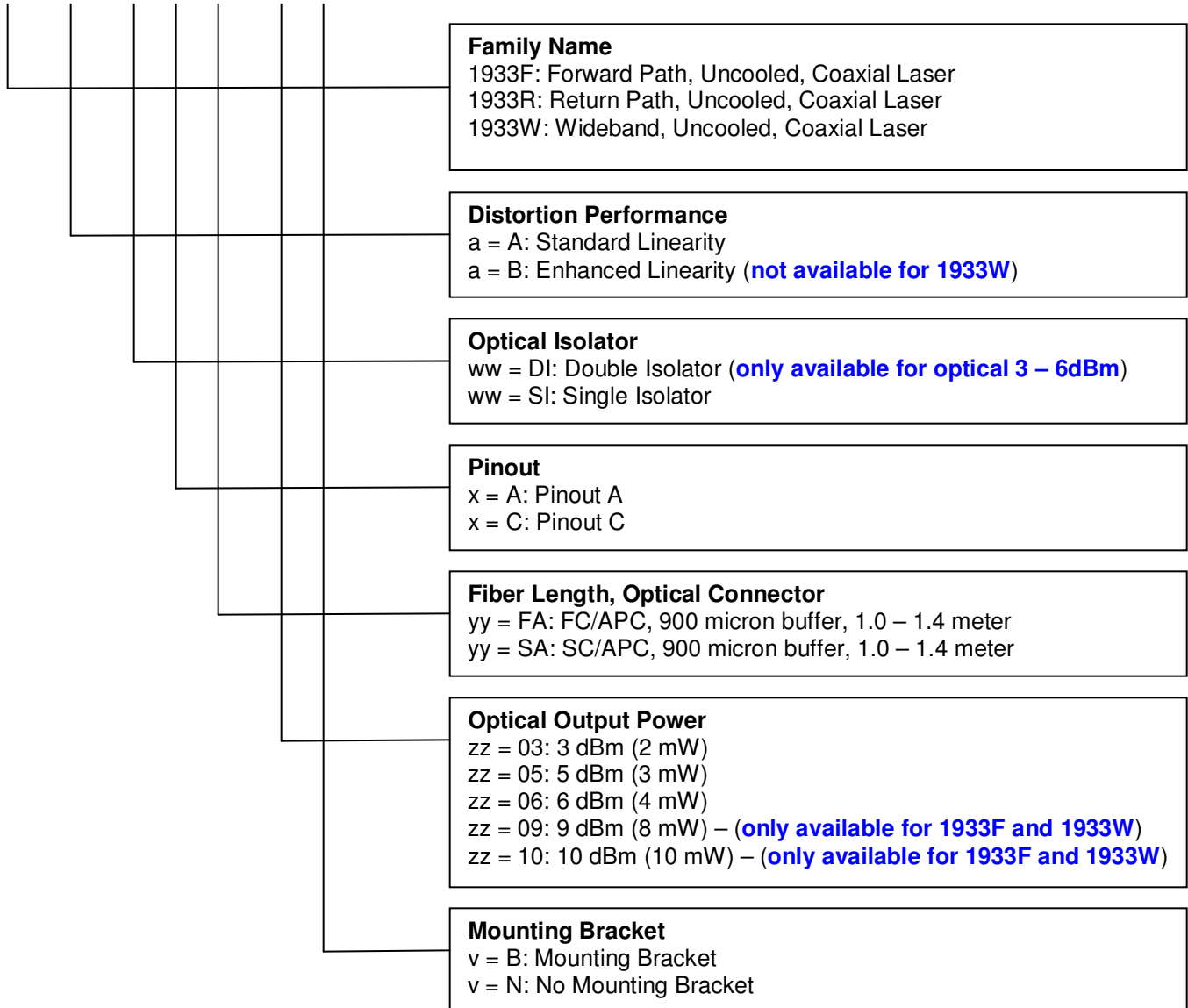

Example

1933F-B-DI-A-SA-10-N: Forward Path Uncooled Coaxial Laser, Enhanced Linearity, Double Isolator, Pinout A, SC/APC optical connector, 10dBm optical power, No Mounting Bracket