

FEATURES

- High Current Transfer Ratio, 800%
- Low Input Current Requirement, 0.5 mA
- High Output Current, 60 mA
- Isolation Test Voltage, 5300 VAC_{RMS}
- TTL Compatible Output, 0.1V V_{OL}
- High Common Mode Rejection, 500V/μsec.
- DC to 0.1 Megabit/Sec. Operation
- Adjustable Bandwidth—Access to Base
- TRIOS (TRansparent IOn Shield)
- Standard Molded Dip Plastic Package
- Underwriters Lab File #E52744
- VDE 0884 Available with Option 1

APPLICATIONS

- Logic Ground Isolation—TTL/TTL, TTL/CMOS, CMOS/CMOS, CMOS/TTL
- EIA RS 232C Line Receiver
- Low Input Current Line Receiver—Long Lines, Party Lines
- Telephone Ring Detector
- 117 VAC Line Voltage Status Indication—Low Input Power Dissipation
- Low Power Systems—Ground Isolation

DESCRIPTION

High common mode transient immunity and very high current ratio together with 5300 VAC_{RMS} insulation are achieved by coupling an LED with an integrated high gain photon detector in an eight pin dual-in-line package. Separate pins for the photodiode and output stage enable TTL compatible saturation voltages with high speed operation. Photodarlington operation is achieved by tying the V_{CC} and V_O terminals together. Access to the base terminal allows adjustment to the gain bandwidth.

The SFH6138 is ideal for TTL applications since the 300% minimum current transfer ratio with an LED current of 1.6 mA enables operation with one unit load-in and one unit load-out with a 2.2 KΩ pull-up resistor.

The SFH6139 is best suited for low power logic applications involving CMOS and low power TTL. A 400% current transfer ratio with only 0.5 mA of LED current is guaranteed from 0°C to 70°C.

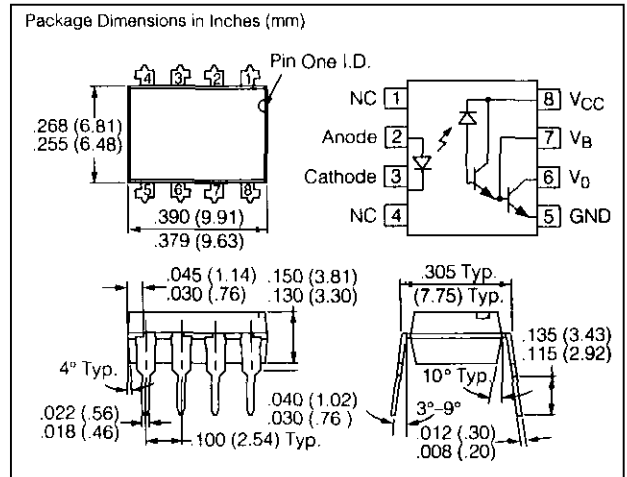

Maximum Ratings

Reverse Input Voltage.....	5 V
Supply and Output Voltage, V _{CC} (pin 8-5), V _O (pin 6-5)	
SFH6138.....	-0.5 to 7 V
SFH6139.....	-0.5 to 18 V
Emitter-Base Reverse Voltage (pin 5-7).....	0.5 V
Average Input Current.....	20 mA
Peak Input Current.....	40 mA
(50% Duty Cycle—1 ms pulse width)	
Peak Transient Input Current	
(tp≤1 μsec, 300 pps).....	1.0 A
Output Current I _O (pin 6).....	60 mA
Derate linearly above 25°C, free air temperature at 0.7 mA/°C	
Input Power Dissipation.....	35mW
Derate linearly above 50%, free air temperature at 0.7 mW/°C	
Output Power Dissipation.....	100 mW
Derate linearly above 25°C, free air temperature at 0.2 mA/°C	
Storage Temperature.....	-55°C to +125°C
Operating Temperature.....	-55°C to +100°C
Lead Soldering Temperature (t=10 sec.).....	260°C
Isolation Test Voltage (t=1 sec.).....	5300 VAC _{RMS}
Isolation Resistance	
V _{IO} =500 V, T _A =25°C.....	≥1012 Ω
V _{IO} =500 V, T _A =100°C.....	≥1011 Ω

Electro-Optical Characteristics ($T_A=0^\circ$ to 70°C , unless otherwise specified)

Parameter	Device	Min.	Typ.	Max.	Units	Test Condition	Note
Current Transfer Ratio (CTR)	SFH6138	300	1600		%	$I_F=1.6\text{ mA}, V_O=0.4\text{ V}, V_{CC}=4.5\text{ V}$	1,2
	SFH6139	400	1600		%	$I_F=0.5\text{ mA}, V_O=0.4\text{ V}, V_{CC}=4.5\text{ V}$	1,2
		500	2000			$I_F=1.6\text{ mA}, V_O=0.4\text{ V}, V_{CC}=4.5\text{ V}$	
Logic Low—Output Voltage (V_{OL})	SFH6138		0.1	0.4	V	$I_F=1.6\text{ mA}, I_O=4.8\text{ mA}, V_{CC}=4.5\text{ V}$	2
	SFH6139		0.1	0.4	V	$I_F=1.6\text{ mA}, I_O=8\text{ mA}, V_{CC}=4.5\text{ V}$	2
	SFH6139		0.15	0.4		$I_F=5\text{ mA}, I_O=15\text{ mA}, V_{CC}=4.5\text{ V}$	
	SFH6139		0.25	0.4		$I_F=12\text{ mA}, I_O=24\text{ mA}, V_{CC}=4.5\text{ V}$	
Logic High—Output Current (I_{OH})	SFH6138		0.1	250	μA	$I_F=0\text{ mA}, V_O=V_{CC}=7\text{ V}$	2
	SFH6139		0.05	100	μA	$I_F=0\text{ mA}, V_O=V_{CC}=18\text{ V}$	2
Logic Low Supply Current (I_{CCL})			0.2	1.5	mA	$I_F=1.6\text{ mA}, V_O=\text{OPEN}, V_{CC}=18\text{ V}$	2
Logic High Supply Current (I_{CCH})			0.001	10	μA	$I_F=0\text{ mA}, V_O=\text{OPEN}, V_{CC}=18\text{ V}$	
Input Forward Voltage (V_F)			1.4	1.7	V	$I_F=1.6\text{ mA}, T_A=25^\circ\text{C}$	
Input Reverse Breakdown Voltage (BV_R)		5			V	$I_R=10\text{ }\mu\text{A}$	
Temperature Coefficient of Forward Voltage			-1.8		mV/ $^\circ\text{C}$	$I_F=1.6\text{ mA}$	
Input Capacitance (C_{IN})			25		pF	$f=1\text{ MHz}, V_F=0$	
Capacitance (Input-Output)			0.6		pF	$f=1\text{ MHz}$	3

Optocouplers
(Optotransistors)

51

Switching Specifications ($T_A=0^\circ$ to 70°C , unless otherwise specified)

Parameter	Device	Min.	Typ.	Max.	Units	Test Condition	Note
Propagation Delay Time To Logic Low at Output t _{PHL}	SFH6138		2	10	μs	$I_F=1.6\text{ mA}, R_L=2.2\text{ K}\Omega$	
	SFH6139		6 0.6	25 1	μs	$I_F=0.5\text{ mA}, R_L=4.7\text{ K}\Omega$ $I_F=12\text{ mA}, R_L=270\text{ K}\Omega$	2,4
Propagation Delay Time To Logic High at Output t _{PLH}	SFH6138		4	35	μs	$I_F=1.6\text{ mA}, R_L=2.2\text{ K}\Omega$	
	SFH6139		5 1	60 7	μs	$I_F=0.5\text{ mA}, R_L=4.7\text{ K}\Omega$ $I_F=12\text{ mA}, R_L=270\text{ K}\Omega$	2,4
Common Mode Transient Immunity at Logic High Level (CM_H) Output			500		V/ μs	$I_F=0\text{ mA}, R_L=2.2\text{ K}\Omega$ $R_{CC}=0/V_{CM}=10\text{ V}_{p-p}$	5,6
Common Mode Transient Immunity at Logic Low Level (CM_L) Output			-500		V/ μs	$I_F=1.6\text{ mA}, R_L=2.2\text{ K}\Omega$ $R_{CC}=0/V_{CM}=10\text{ V}_{p-p}$	5,6

Notes

- DC current transfer ratio is defined as the ratio of output collector current, I_O , to the forward LED input current, I_F times 100%.
- Pin 7 open.
- Device considered a two-terminal device: pins 1, 2, 3 and 4 shorted together and pins 5, 6, 7 and 8 shorted together.
- Using a resistor between pin 5 and 7 will decrease gain and delay time.
- Common mode transient immunity in logic high level is the maximum tolerable (positive) dV_{CM}/dt on the leading edge of the common mode pulse, V_{CM} , to assure that the output will remain in a logic high state (i.e. $V_O > 2.0\text{ V}$) common mode transient immunity in logic low level is the maximum tolerable (negative) dV_{CM}/dt on the trailing edge of the common mode pulse signal, V_{CM} , to assure that the output will remain in a logic low state (i.e. $V_O < 0.8\text{ V}$).
- In applications where dv/dt may exceed 50,000 V/ μs (such as state discharge) a series resistor, R_{CC} should be included to protect I_C from destructively high surge currents. The recommended value is $R_{CC} \approx \frac{IV}{0.15 I_F (\text{mA})} \text{ k}\Omega$