

## Rear Window Heating Timer/ Long-Term Timer

### Description

The bipolar long-term timers U6046B and U6047B are designed to limit the operation time of high loads in the harsh automotive environment automatically by a preset delay time. With the power-on-reset function the timers

guarantee that current consuming devices are not operated unintentionally.

The delay time can be interrupted manually, but a retrigger function is not provided.

### Features

- Delay time range: 3.7 s to 20 h
- RC oscillator determines timing characteristics
- Relay driver with Z-diode
- Debounced input for toggle switch
- Two debounced inputs: ON and OFF
- Load-dump protection
- RF interference protected
- Protection according to ISO/TR7637-1 (VDE 0839)
- U6046B: Inputs switched to  $V_{Batt}$
- U6047B: Inputs switched to ground

### Block Diagram

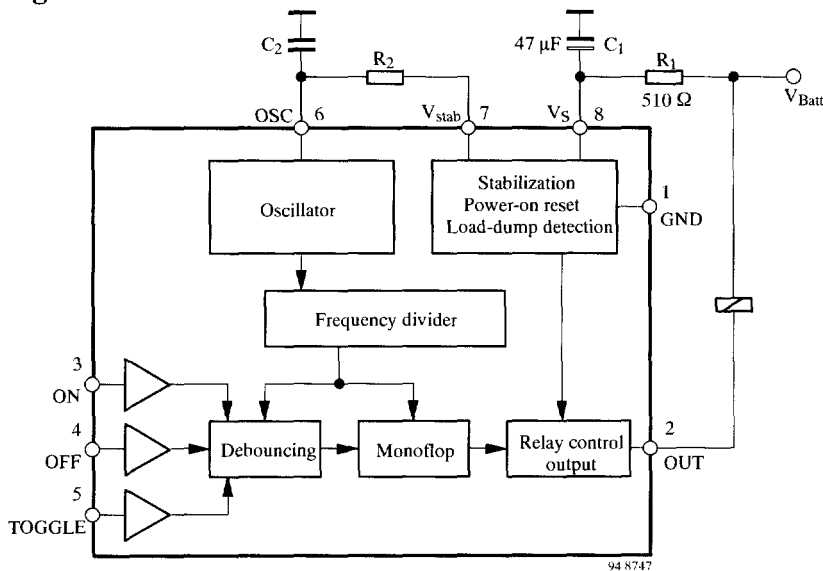

Figure 1. Block diagram with external circuit

### Ordering Information

Extended Type Number	Package	Remarks
U6046B, U6047B	DIP8	
U6046B-FP, U6047B-FP	SO8	

## Pin Description

Pin	Symbol	Function
1	GND	Reference point, ground
2	OUT	Relay control output
3	ON	Switch-on input
4	OFF	Switch-off input
5	TOGGLE	Toggle input
6	OSC	RC oscillator input
7	V <sub>stab</sub>	Stabilized voltage
8	V <sub>S</sub>	Supply voltage

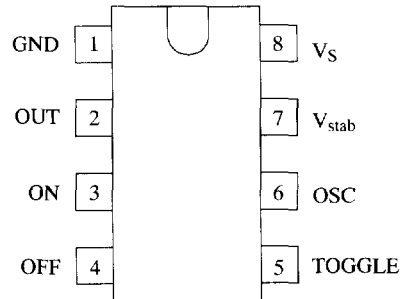

94 8844

Figure 2. Pinning

## Functional Description

### Power Supply, Pin 8

For reasons of interference protection and surge immunity, the supply voltage (Pin 8) must be provided with an RC circuit as shown in figure 3. Dropper resistor,  $R_1$ , limits the current in case of overvoltage, whereas  $C_1$  smoothes the supply voltage at Pin 8.

Recommended values are:  $R_1 = 510 \Omega$ ,  $C_1 = 47 \mu\text{F}$ .

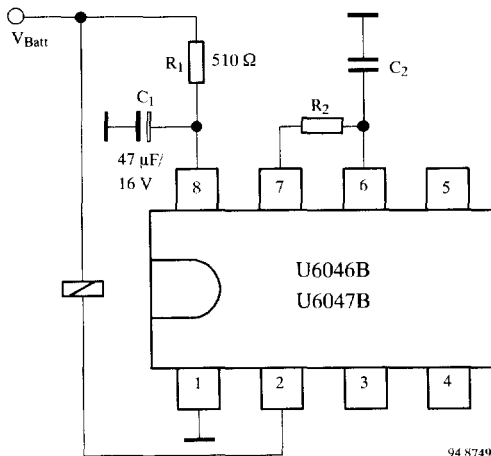

94 8749

Figure 3. Basic circuit for 12 V supply and oscillator

The integrated Z-diode (14 V) protects the supply voltage,  $V_S$ . Therefore, the operation of the IC is possible between 6 V and 16 V, supplied by  $V_{\text{Batt}}$ .

However, it is possible to operate the integrated circuit with a 5 V supply, but it should be free of interference voltages. In this case, Pin 7 is connected to Pin 8 as shown in figure 4, and the  $R_1 C_1$  circuit is omitted.

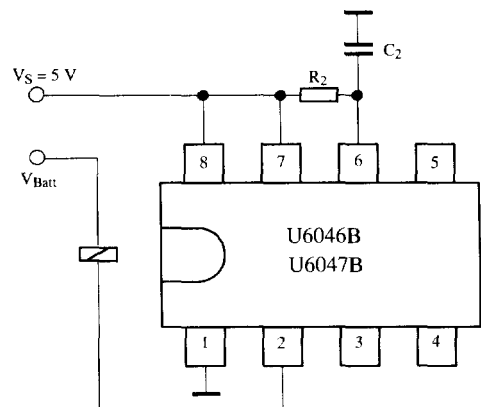

94 8750

Figure 4. Basic circuit for  $V_S = 5 \text{ V}$

## Oscillator, Pin 6

The external components  $R_2$  and  $C_2$  determine the oscillator frequency. The capacitor  $C_2$  is charged by  $R_2$  and discharged by an integrated 2-k $\Omega$  resistor.

A stable oscillator frequency with minimal influence of the temperature coefficient of the integrated resistor is achieved with  $R_2 \gg 2 \text{ k}\Omega$ .

Oscillator frequency,  $f$ , is calculated as follows:

$$f = \frac{1}{t_1 + t_2}$$

where

$$t_1 = \text{charge time} = \alpha_1 \times R_2 \times C_2$$

$$t_2 = \text{discharge time} = \alpha_2 \times 2 \text{ k}\Omega \times C_2$$

$\alpha_1$  and  $\alpha_2$  are constants as such

$\alpha_1 = 0.833$  and  $\alpha_2 = 1.551$  when  $C_2 = 470 \text{ pF}$  to  $10 \text{ nF}$

$\alpha_1 = 0.746$  and  $\alpha_2 = 1.284$  when  $C_2 = 10 \text{ nF}$  to  $4700 \text{ nF}$

The debounce time,  $t_3$ , and the delay time,  $t_d$ , depend on the oscillator frequency,  $f$ , as follows:

$$t_3 = 6 \times \frac{1}{f}$$

$$t_d = 73728 \times \frac{1}{f}$$

Table 1 shows relationships between  $t_3$ ,  $t_d$ ,  $C_2$ ,  $R_2$  and frequencies from 1 Hz to 20 kHz.

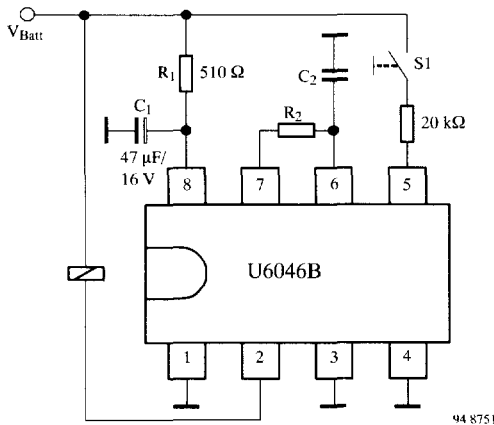

Figure 5. TOGGLE function U6046B

## Relay Control Output (OUT)

The relay control output is an open-collector Darlington circuit with an integrated 23-V Z-diode for limitation of the inductive cut-off pulse of the relay coil. The maximum static collector current must not exceed 300 mA and saturation voltage is typically 1.1 V @ 200 mA.

## Interference Voltages and Load-Dump

The IC supply is protected by  $R_1$ ,  $C_1$ , and an integrated Z-diode, while the inputs are protected by a series resistor, integrated Z-diode and RF capacitor (refer to figures 10 and 11).

The relay control output is protected via the integrated 23-V Z-diode in the case of short interference peaks. It is switched to conductive condition for a battery voltage of greater than approx. 40 V in the case of load-dump. The output transistor is dimensioned so that it can withstand the current produced.

## Power-on Reset

When the operating voltage is switched on, an internal power-on reset pulse (POR) is generated which sets the logic of the circuits to a defined initial condition. The relay output is disabled.

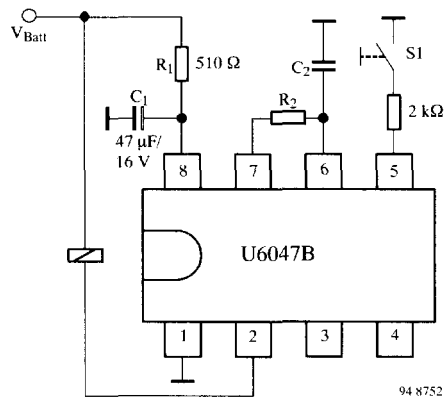

Figure 6. TOGGLE function U6047B

## Relay Control Output Behavior, Pin 2

Time functions (relay output) can be started or interrupted by the three inputs i.e., ON, OFF or TOGGLE (Pins 3, 4 and 5).

The relay becomes active if the time function is triggered, and the relay contact is interrupted after the elapse of delay time,  $t_d$ . There are two input possibilities:

### Toggle Input, Figures 5 and 6

When the push-button (TOGGLE) switch,  $S_1$ , is pressed for the first time, the relay becomes active after the debounce time,  $t_3$ , i.e., the relay output, Pin 2, is active.

Renewed operation of  $S_1$  causes the interruption of the relay contact and the relay is disabled. Each operation of the toggle switch,  $S_1$ , changes (alters) the condition of the relay output when the debounce time,  $t_3$ , is exceeded i.e., the TOGGLE function.

If the relay output is not disabled by pressing the switch  $S_1$ , the output is active until the delay time,  $t_d$ , is over.

### ON, OFF Inputs, Pins 3 and 4, Figures 7 and 8

To avoid simultaneous operation of both inputs, Pin 3 (ON) and Pin 4 (OFF), use of two-way contact with centre-off position with spring returns (also known as rocker-actuated switch) is recommended.

Pressing the push-button switch (Pin 3-ON) leads to the activation of the relay after the debounce time,  $t_3$ ,

whereas the switching of the Pin 4 switch correspondingly leads to the relay being de-energized. If the relay is not de-energized by the push-button switch, it becomes disabled after the delay time,  $t_d$ , is over.

Combined operation, "TOGGLE and ON/OFF" is not possible because both inputs are connected to the same debounce stage. Debouncing functions on both edges i.e., whenever  $S_1$  is ON or OFF.

If Pin 3 (input ON) is continuously closed, the delay time,  $t_d$ , still elapses and the relay is interrupted. This can be used to generate a defined power-on-reset pulse to trigger, for example, a delay time,  $t_d$ , when the battery voltage,  $V_{Batt}$ , is applied.

Figure 10 shows the input circuit of U6046B. It has an integrated pull-down resistance (20 kΩ), RF capacitor (15 pF) and Z-diode (7 V). It reacts to voltages greater than 2 V. The external protective resistor has a value of 20 kΩ and the push-button switch,  $S$ , is connected to the battery as shown in the diagram.

Contact current,  $I$ , is calculated as follows:

$$I = \frac{V_{Batt} - V_Z}{R(= 20\text{ k}\Omega)} \quad \text{where } V_{Batt} = 12\text{ V}, V_Z = 7\text{ V}$$

$$I = \frac{(12-7)\text{ V}}{20\text{ k}\Omega} \approx 0.25\text{ mA}$$

It can be increased by connecting a 5.6 kΩ resistor from the push-button switch to ground as shown in figure 15.

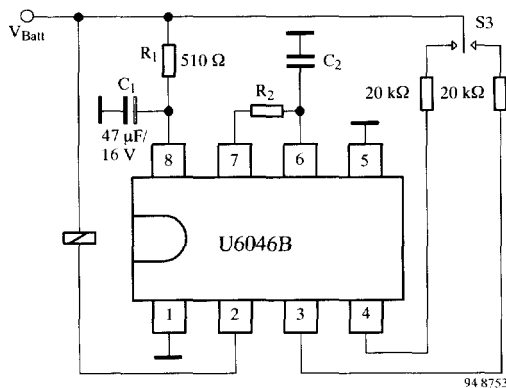

Figure 7. ON/OFF function U6046B

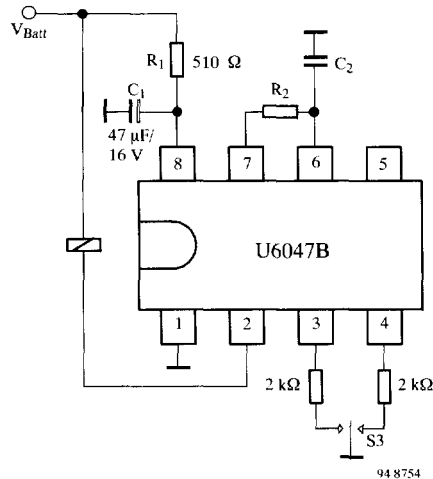

Figure 8. ON/OFF function U6047B

Figure 11 shows the input circuit of U6047B. It has an integrated pull-up resistance (100 k $\Omega$ ), RF capacitor (15 pF) and Z-diode (7 V). The circuit reacts to voltages less than 2 V. The external protective resistance has a value of 2 k $\Omega$  and the push-button switch is connected to GND. Contact current, I, is calculated as follows:

$$I \approx \frac{V_s}{(100 \text{ k}\Omega + 2 \text{ k}\Omega)} \text{ when } V_{\text{Batt}} = 12 \text{ V}$$

$$I \approx 0.1 \text{ mA}$$

It can be increased by connecting a 5.6 k $\Omega$  resistor from the push-button-switch to  $V_{\text{Batt}}$  as shown in figure 15.

The diodes prevent the IC from a current flow into the input stage when the rocker switch is open.

**Timing Waveform**

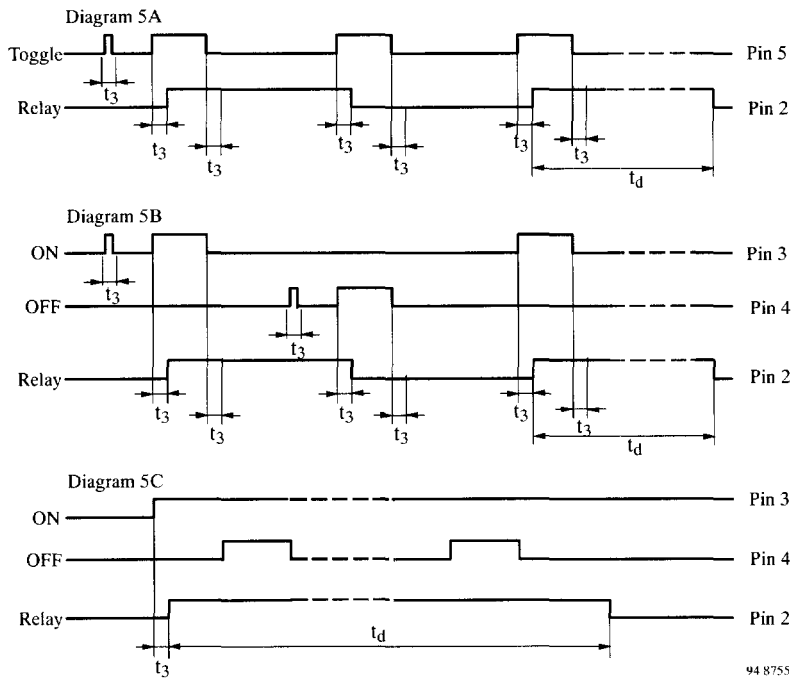

Figure 9. Behavior of the relay control output as a function of input condition

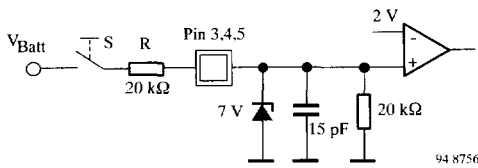

Figure 10. Input circuit U6046B

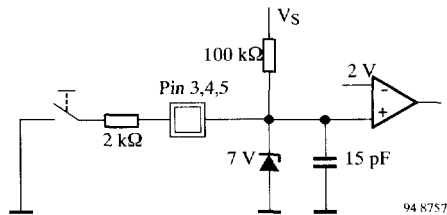

Figure 11. Input circuit U6047B

# U6046B/ U6047B



## Absolute Maximum Ratings

Parameters	Symbol	Value	Unit
Operating voltage, static, 5 min	$V_{Batt}$	24	V
Ambient temperature range	$T_{amb}$	-40 to +125	°C
Storage temperature range	$T_{stg}$	-55 to +125	°C
Junction temperature	$T_j$	150	°C

## Thermal Resistance

Parameters	Symbol	Maximum	Unit
Junction ambient DIP8 SO8	$R_{thJA}$	120	K/W
	$R_{thJA}$	160	K/W

## Electrical Characteristics

$V_{Batt} = 13.5$  V,  $T_{amb} = 25$ °C, reference point ground, figure 2, unless otherwise specified

Parameters	Test Conditions / Pin	Symbol	Min	Typ	Max	Unit
Operating voltage	$R_1 \geq 510 \Omega$ $t < 5$ min $t < 60$ min	$V_{Batt}$	6		16	V
					24	
					18	
5 V supply	Without $R_1$ , $C_1$ figure 4 Pins 7 and 8	$V_8$ , $V_7$	4.3		6.0	V
Stabilized voltage	$V_{Batt} = 12$ V Pin 7	$V_7$	5.0	5.2	5.4	V
Undervoltage threshold	Power on reset	$V_8$	3.0		4.2	V
Supply current	All push buttons open, Pin 8	$I_8$		1.3	2.0	mA
Internal Z-diode	$I_8 = 10$ mA Pin 8	$V_8$	13.5	14	16	V
<b>Relay control output</b> Pin 2						
Saturation voltage	$I_2 = 200$ mA $I_2 = 300$ mA	$V_2$		1.2	1.5	V
Leakage current	$V_2 = 14$ V	$I_2$		2	100	μA
Output current		$I_2$			300	mA
<b>Output pulse current</b>						
Load dump pulse	$t \leq 300$ ms	$I_2$			1.5	A
Internal Z-diode	$I_2 = 10$ mA	$V_2$	20	22	24	V
<b>Oscillator input</b> $f = 0.001$ to 40 kHz, see table 1 Pin 6						
Internal discharge resistance	$V_6 = 5$ V	$R_6$	1.6	2.0	2.4	kΩ
Switching voltage	Lower Upper	$V_{6L}$ $V_{6H}$	0.9	1.1	1.4	V
			2.8	3.1	3.5	
Input current	$V_6 = 0$ V	$-I_6$			1	μA
<b>Switching times</b>						
Debounce time		$t_3$	5		7	cycles
Delay time		$t_d$	72704		74752	cycles

## Electrical Characteristics

$V_{Batt} = 13.5\text{ V}$ ,  $T_{amb} = 25^\circ\text{C}$ , reference point ground, figure 2, unless otherwise specified

Parameters	Test Conditions / Pin	Symbol	Min	Typ	Max	Unit
<b>Inputs ON, OFF, TOGGLE</b> Pins 3, 4 and 5						
Switching threshold voltage		$V_{3,4,5}$	1.6	2.0	2.4	V
Internal Z-diode	$I_{3,4,5} = 10\text{ mA}$	$V_{3,4,5}$	6.5	7.1	8.0	V
Pull-down resistance	$V_{3,4,5} = 5\text{ V}$ U 6046 B	$R_{3,4,5}$	13	20	50	k $\Omega$
Pull-up resistance	$V_{3,4,5} = 0\text{ V}$ U 6047 B	$R_{3,4,5}$	70	100	140	k $\Omega$

Table 1 Dimensioning for oscillator frequency, debounce time and delay time.

Fre- quency f	De- bounce Time $t_3$	Delay Time		$C_2$ nF	$R_2$ k $\Omega$
		min	s		
1	6000	1229		4700	280
2	3000	614		1000	650
3	2000	410		1000	440
4	1500	307		1000	330
5	1200	246		1000	260
6	1000	205		1000	220
7	857	176		1000	190
8	750	154		1000	160
9	667	137		1000	140
10	600	123		1000	130
20	300	61		100	650
30	200	41		100	440
40	150	31		100	330
50	120	25		100	260
60	100	20		100	220
70	86	18		100	190
80	75	15		100	160
90	67	14		100	140
100	60	12		100	130
200	30		369	10	600
300	20		246	10	400
400	15		184	10	300
500	12		147	10	240
600	10		123	10	200

Fre- quency f	De- bounce Time $t_3$	Delay Time		$C_2$ nF	$R_2$ k $\Omega$
		min	s		
700	9.00		105	10	170
800	8.00		92	10	150
900	7.00		82	10	130
1000	6.00		74	10	120
2000	3.00		37	1	600
3000	2.00		25	1	400
4000	1.50		18	1	300
5000	1.20		15	1	240
6000	1.00		12	1	200
7000	0.86		11	1	170
8000	0.75		9	1	150
9000	0.67		8	1	130
10000	0.60		7	1	120
11000	0.55		6.7	1	110
12000	0.50		6.1	1	99
13000	0.46		5.7	1	91
14000	0.43		5.3	1	85
15000	0.40		4.9	1	79
16000	0.38		4.6	1	74
17000	0.35		4.3	1	70
18000	0.33		4.1	1	66
19000	0.32		3.9	1	62
20000	0.30		3.7	1	59

## Applications

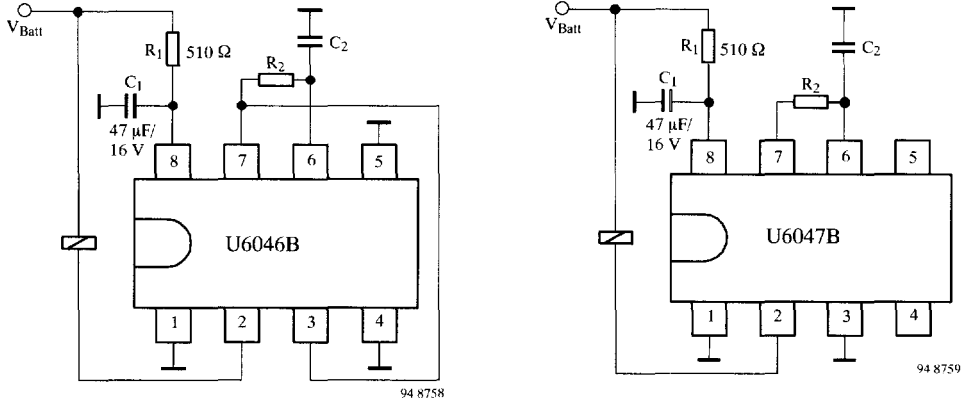

Figure 12. Generation of a monostable delay time,  $t_d$ , caused by applying the operating voltage  $V_{Batt}$ , not externally deactivatable.

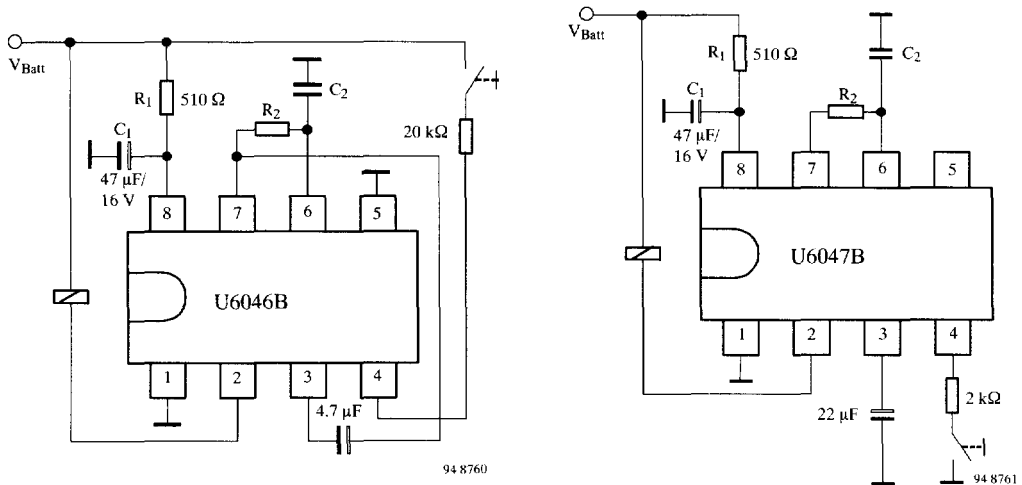

Figure 13. Generation of a monostable delay time,  $t_d$ , by applying the operating voltage  $V_{Batt}$ , deactivatable by the OFF push-button

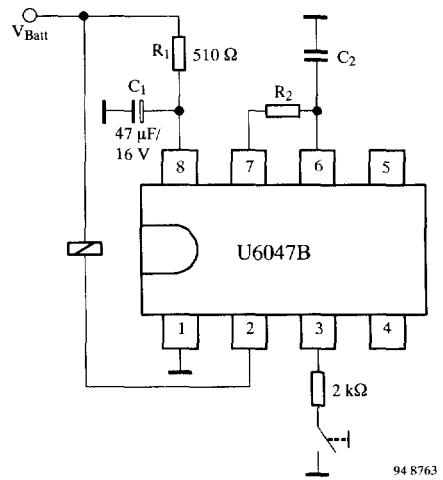
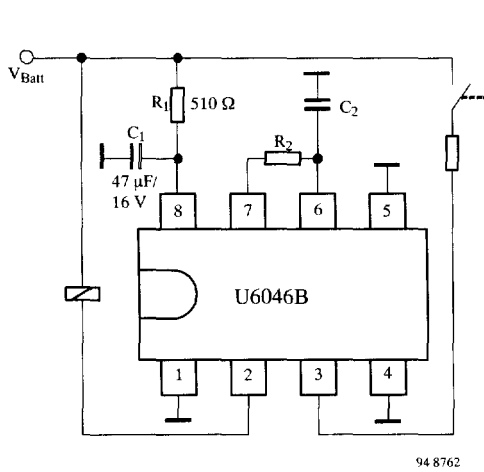

Figure 14. Monostable delay time,  $t_d$ , can be activated by the ON push-button, not externally deactivatable

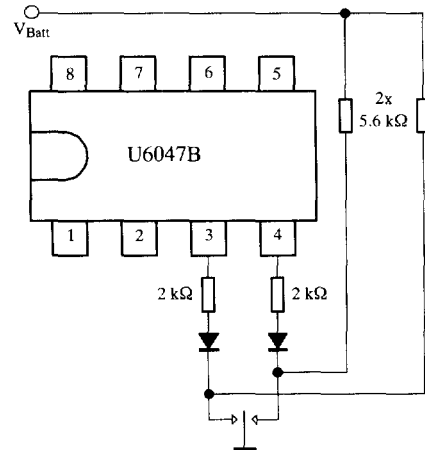
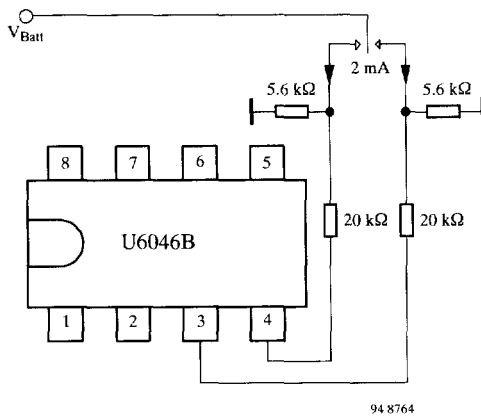

Figure 15. Increasing the contact current by parallel resistors

# U6046B/ U6047B



## Package Information

Package DIP8

Dimensions in mm

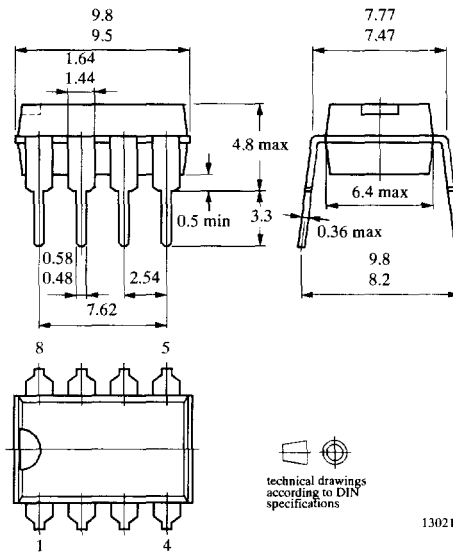

## Package SO8

Dimensions in mm

