



# 12-Bit, 25MHz Sampling ANALOG-TO-DIGITAL CONVERTER

## FEATURES

- NO MISSING CODES
- LOW POWER: 270mW
- INTERNAL REFERENCE
- WIDEBAND TRACK-AND-HOLD: 65MHz
- SINGLE +5V SUPPLY

## APPLICATIONS

- IF AND BASEBAND DIGITIZATION
- DIGITAL COMMUNICATIONS
- TEST INSTRUMENTATION
- CCD IMAGING
  - Copiers
  - Scanners
  - Cameras
- VIDEO DIGITIZING
- GAMMA CAMERAS

## DESCRIPTION

The ADS801 is a low-power, monolithic 12-bit, 25MHz Analog-to-Digital (A/D) converter utilizing a small geometry CMOS process. This complete converter includes a 12-bit quantizer, wideband track-and-hold, reference, and three-state outputs. It operates from a single +5V power supply and can be configured to accept either single-ended or differential input signals.

The ADS801 employs digital error correction to provide excellent Nyquist differential linearity performance for demanding imaging applications. Its low distortion, high SNR, and high oversampling capability give it the extra margin needed for telecommunications, instrumentation, and video applications.

This high-performance A/D converter is specified over temperature for AC and DC performance at a 25MHz sampling rate. The ADS820 is available in an SO-28 package.

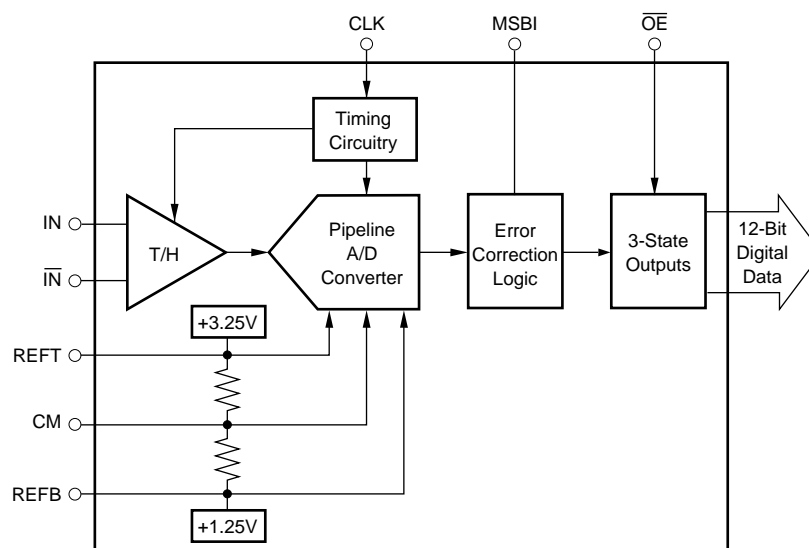

Please be aware that an important notice concerning availability, standard warranty, and use in critical applications of Texas Instruments semiconductor products and disclaimers thereto appears at the end of this data sheet.

All trademarks are the property of their respective owners.

## ABSOLUTE MAXIMUM RATINGS<sup>(1)</sup>

+V <sub>S</sub> .....	+6V
Analog Input .....	0V to (+V <sub>S</sub> + 300mV)
Logic Input .....	0V to (+V <sub>S</sub> + 300mV)
Case Temperature .....	+100°C
Junction Temperature .....	+150°C
Storage Temperature .....	+125°C
External Top Reference Voltage (REFT) .....	+3.4V Max
External Bottom Reference Voltage (REFB) .....	+1.1V Min

NOTE: (1) Stresses above these ratings may permanently damage the device.



## ELECTROSTATIC DISCHARGE SENSITIVITY

This integrated circuit can be damaged by ESD. Texas Instruments recommends that all integrated circuits be handled with appropriate precautions. Failure to observe proper handling and installation procedures can cause damage.

ESD damage can range from subtle performance degradation to complete device failure. Precision integrated circuits may be more susceptible to damage because very small parametric changes could cause the device not to meet its published specifications.

## PACKAGE/ORDERING INFORMATION<sup>(1)</sup>

PRODUCT	PACKAGE-LEAD	PACKAGE DESIGNATOR	SPECIFIED TEMPERATURE RANGE	PACKAGE MARKING	ORDERING NUMBER	TRANSPORT MEDIA, QUANTITY
ADS801U	SO-28	DW	-40°C to +85°C	ADS801U	ADS801U	Rails, 28
ADS801U	"	"	"	"	ADS801U/1K	Tape and Reel, 1000

NOTE: (1) For the most current package and ordering information, see the Package Option Addendum at the end of this document, or see the TI website at [www.ti.com](http://www.ti.com).

## ELECTRICAL CHARACTERISTICS

At T<sub>A</sub> = +25°C, V<sub>S</sub> = +5V, Sampling Rate = 25MHz, and with a 50% duty cycle clock having a 2ns rise-and-fall time, unless otherwise noted.

PARAMETER	CONDITIONS	TEMP	ADS800U			UNITS
			MIN	TYP	MAX	
Resolution				12		Bits
Specified Temperature Range	T <sub>AMBIENT</sub>		-40		+85	°C
<b>ANALOG INPUT</b>						
Differential Full-Scale Input Range	Both Inputs, 180° Out-of-Phase		+1.25		+3.25	V
Common-Mode Voltage				+2.25		V
Analog Input Bandwidth (-3dB)				400		MHz
Small-Signal	-20dBFS <sup>(1)</sup> Input	+25°C		65		MHz
Full-Power	0dBFS Input	+25°C		1.25    4		MΩ    pF
Input Impedance						
<b>DIGITAL INPUT</b>						
Logic Family				TTL/HCT Compatible CMOS		
Convert Command	Start Conversion			Falling Edge		
<b>ACCURACY<sup>(2)</sup></b>						
Gain Error		f <sub>S</sub> = 2.5MHz +25°C Full		±0.6 ±1.0 ±85	±1.5 ±2.5	% %
Gain Tempco				±85		ppm/°C
Power-Supply Rejection of Gain	Δ +V <sub>S</sub> = ±5%	+25°C		0.03	0.15	%FSR/%
Input Offset Error		Full		±2.1	±3.0	%
Power-Supply Rejection of Offset	Δ +V <sub>S</sub> = ±5%	+25°C		0.05	0.15	%FSR/%
<b>CONVERSION CHARACTERISTICS</b>						
Sample Rate			10k		25M	Sample/s
Data Latency				6.5		Convert Cycle
<b>DYNAMIC CHARACTERISTICS</b>						
Differential Linearity Error						
f = 500kHz		+25°C 0°C to +85°C		±0.3 ±0.4	±1.0 ±1.0	LSB LSB
f = 10MHz		+25°C 0°C to +85°C		±0.3 ±0.4	±1.0 ±1.0	LSB LSB
No Missing Codes		0°C to +85°C		Tested		LSB
Integral Linearity Error at f = 500kHz		Full		±1.7		LSB
Spurious-Free Dynamic Range (SFDR)						
f = 500kHz (-1dBFS input)		+25°C	63	77		dBFS
f = 10MHz (-1dBFS input)		Full	62	73		dBFS
		+25°C	57	61		dBFS
		Full	55	61		dBFS

NOTES: (1) dBFS refers to dB below Full-Scale. (2) Percentage accuracies are referred to the internal A/D converter Full-Scale Range of 4V<sub>p-p</sub>. (3) IMD is referred to the larger of the two input signals. If referred to the peak envelope signal (=0dB), the intermodulation products will be 7dB lower. (4) No "rollover" of bits.

# ELECTRICAL CHARACTERISTICS (Cont.)

At  $T_A = +25^\circ\text{C}$ ,  $V_S = +5\text{V}$ , Sampling Rate = 25MHz, and with a 50% duty cycle clock having a 2ns rise-and-fall time, unless otherwise noted.

PARAMETER	CONDITIONS	TEMP	ADS800U			UNITS
			MIN	TYP	MAX	
<b>DYNAMIC CHARACTERISTICS (Cont.)</b>						
2-Tone Intermodulation Distortion (IMD) <sup>(3)</sup> f = 4.4MHz and 4.5MHz (−7dBFS each tone)		+25°C Full		−64 −63		dBc dBc
Signal-to-Noise Ratio (SNR) f = 500kHz (−1dBFS input)		+25°C Full	64 61	66 64		dB dB
f = 10MHz (−1dBFS input)		+25°C Full	62 58	65 64		dB dB
Signal-to-(Noise + Distortion) (SINAD) f = 500kHz (−1dBFS input)		+25°C Full	63 60	66 63		dB dB
f = 10MHz (−1dBFS input)		+25°C Full	56 54	59 58		dB dB
Differential Gain Error	NTSC or PAL	+25°C		0.5		%
Differential Phase Error	NTSC or PAL	+25°C		0.1		degrees
Aperture Delay Time		+25°C		2		ns
Aperture Jitter		+25°C		7		ps rms
Over-Voltage Recovery Time <sup>(4)</sup>	1.5x Full-Scale Input	+25°C		2		ns
<b>OUTPUTS</b>						
Logic Family				TTL/HCT Compatible CMOS		
Logic Coding				Falling Edge		
Logic Levels	Logic Selectable Logic LOW, $C_L = 15\text{pF max}$ Logic HIGH, $C_L = 15\text{pF max}$	Full	0		0.4	V
		Full	+2.5		+ $V_S$	V
3-State Enable Time				20	40	ns
3-State Disable Time		Full		2	10	ns
<b>POWER-SUPPLY REQUIREMENTS</b>						
Supply Voltage: + $V_S$	Operating	Full	+4.75	+5.0	+5.25	V
Supply Current: + $I_S$	Operating	+25°C		54	65	mA
	Operating	Full		54	68	mA
Power Consumption	Operating	+25°C		270	325	mW
	Operating	Full		270	340	mW
Thermal Resistance, $\theta_{JA}$ SO-28				75		°C/W

NOTES: (1) dBFS refers to dB below Full-Scale. (2) Percentage accuracies are referred to the internal A/D converter Full-Scale Range of 4Vp-p. (3) IMD is referred to the larger of the two input signals. If referred to the peak envelope signal (=0dB), the intermodulation products will be 7dB lower. (4) No "rollover" of bits.

## PIN CONFIGURATION

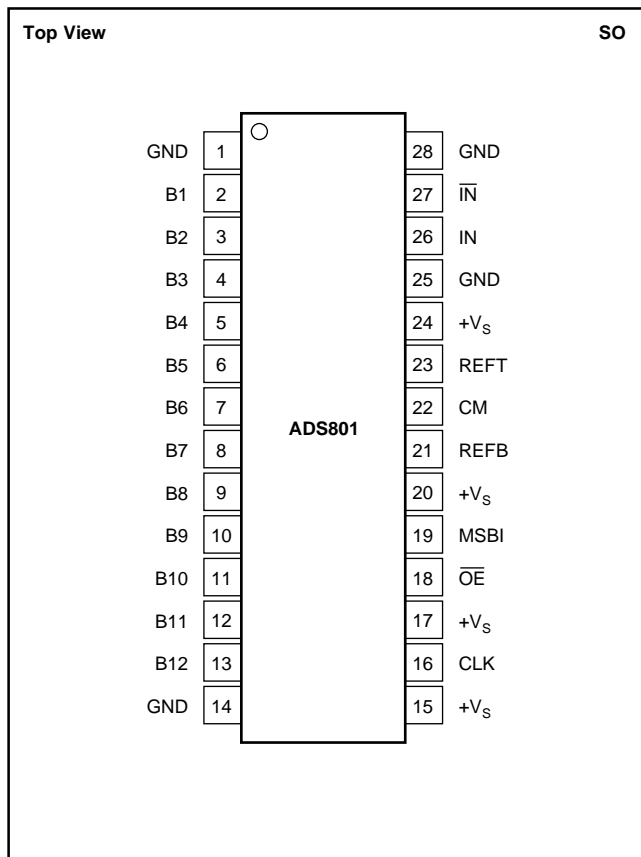

## PIN DESCRIPTIONS

PIN	DESIGNATOR	DESCRIPTION
1	GND	Ground
2	B1	Bit 1, Most Significant Bit (MSB)
3	B2	Bit 2
4	B3	Bit 3
5	B4	Bit 4
6	B5	Bit 5
7	B6	Bit 6
8	B7	Bit 7
9	B8	Bit 8
10	B9	Bit 9
11	B10	Bit 10
12	B11	Bit 11
13	B12	Bit 12, Least Significant Bit (LSB)
14	GND	Ground
15	+V <sub>S</sub>	+5V Power Supply
16	CLK	Convert Clock Input, 50% Duty Cycle
17	+V <sub>S</sub>	+5V Power Supply
18	OE	HIGH: High-Impedance State. LOW or Floating: Normal Operation. Internal pull-down resistors.
19	MSBI	Most Significant Bit Inversion, HIGH: MSB inverted for complementary output. LOW or Floating: Straight output. Internal pull-down resistors.
20	+V <sub>S</sub>	+5V Power Supply
21	REFB	Bottom Reference Bypass. For external bypassing of internal +1.25V reference.
22	CM	Common-Mode Voltage. It is derived by (REFT + REFB)/2.
23	REFT	Top Reference Bypass. For external bypassing of internal +3.25V reference.
24	+V <sub>S</sub>	+5V Power Supply
25	GND	Ground
26	IN	Input
27	IN	Complementary Input
28	GND	Ground

## TIMING DIAGRAM

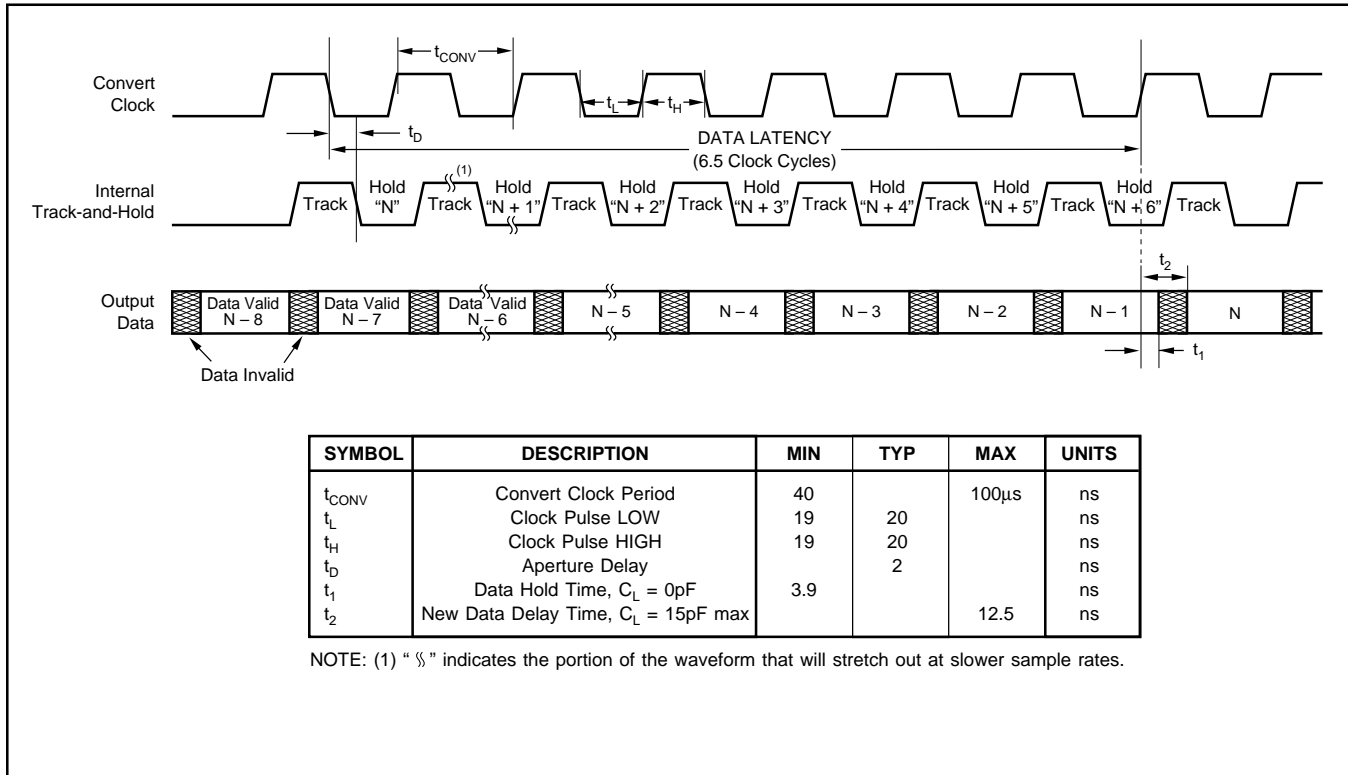

# TYPICAL CHARACTERISTICS

At  $T_A = +25^\circ\text{C}$ ,  $V_S = +5\text{V}$ , Sampling Rate = 25MHz, and with a 50% duty cycle clock having a 2ns rise-and-fall time, unless otherwise noted.

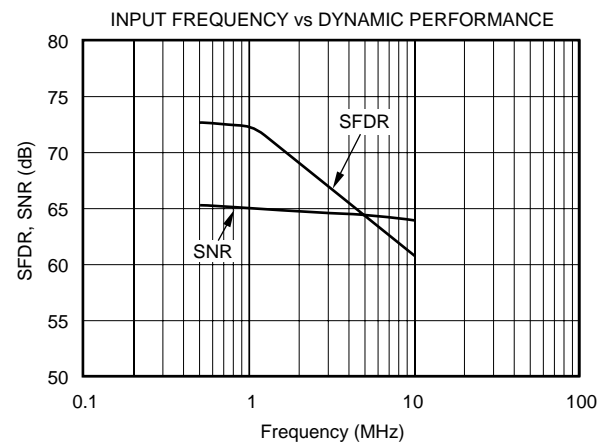
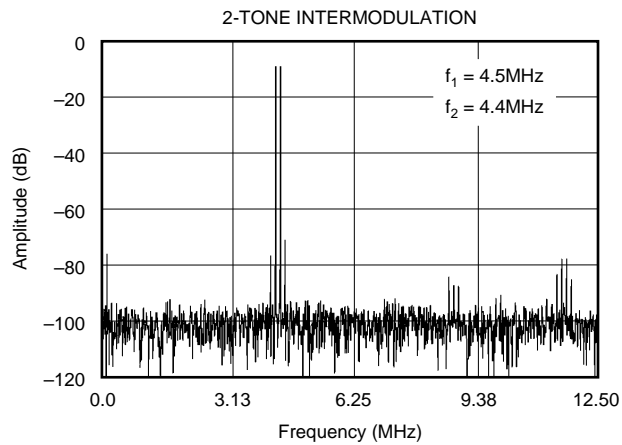
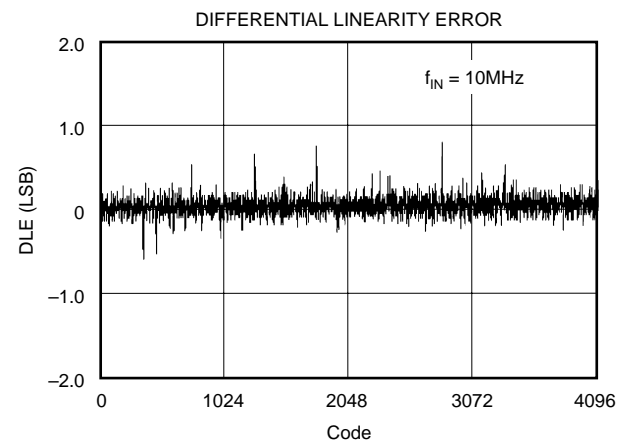
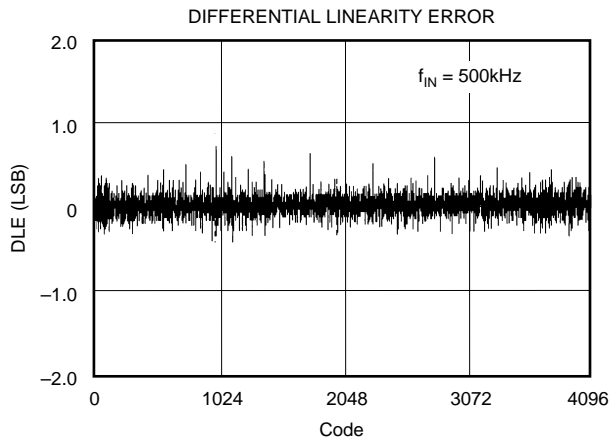
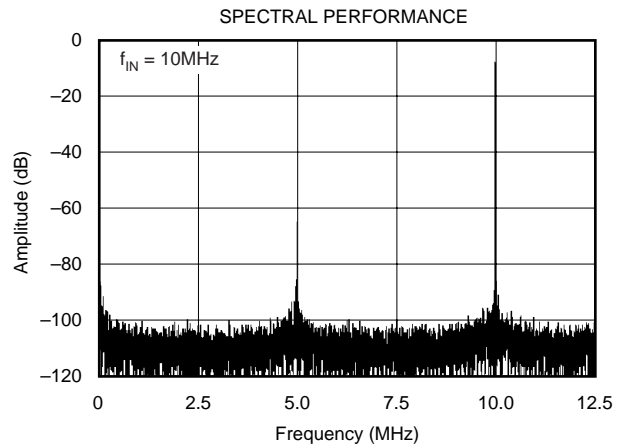
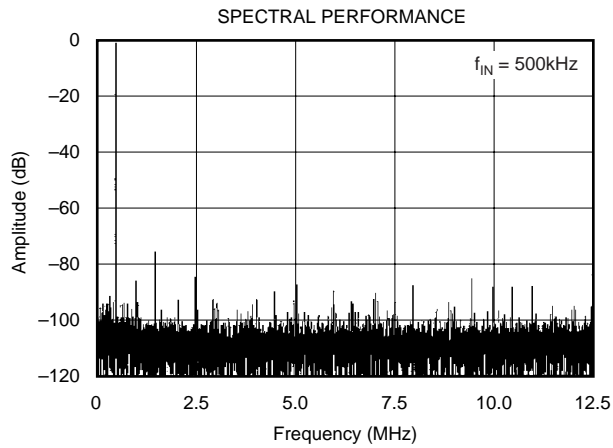

# TYPICAL CHARACTERISTICS (Cont.)

At  $T_A = +25^\circ\text{C}$ ,  $V_S = +5\text{V}$ , Sampling Rate = 25MHz, and with a 50% duty cycle clock having a 2ns rise-and-fall time, unless otherwise noted.

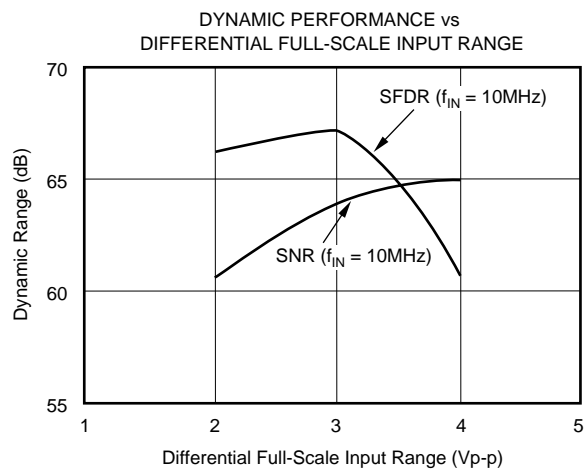
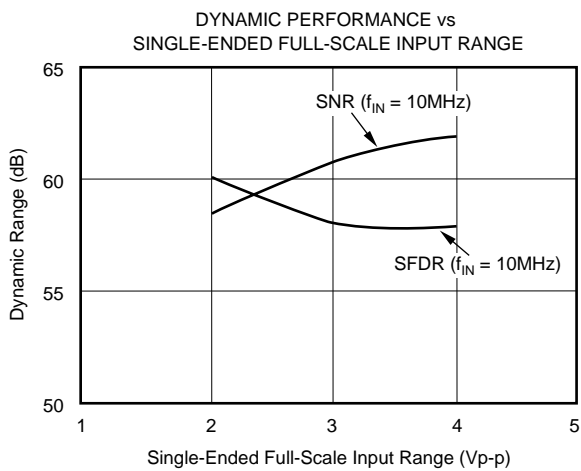
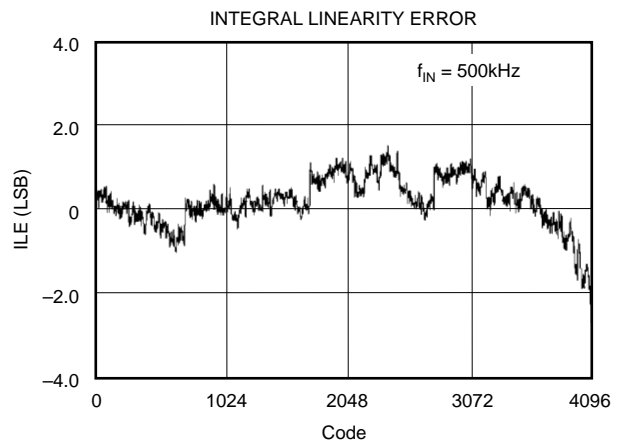
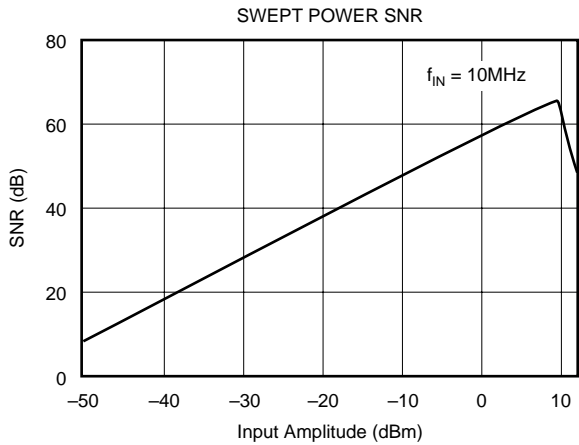
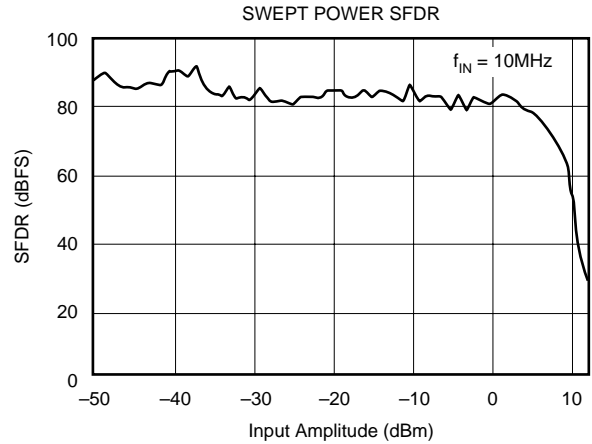
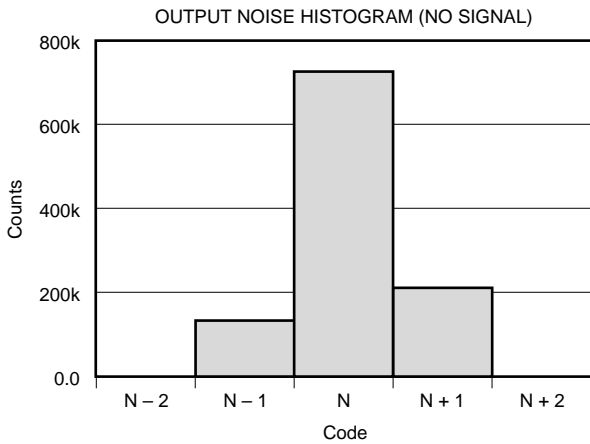

# TYPICAL CHARACTERISTICS (Cont.)

At  $T_A = +25^\circ\text{C}$ ,  $V_S = +5\text{V}$ , Sampling Rate = 25MHz, and with a 50% duty cycle clock having a 2ns rise-and-fall time, unless otherwise noted.

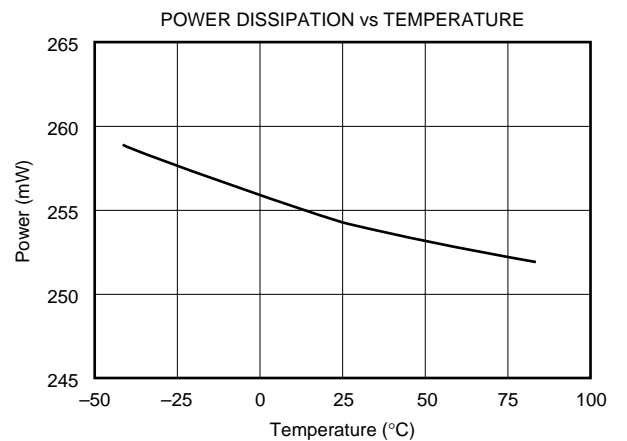
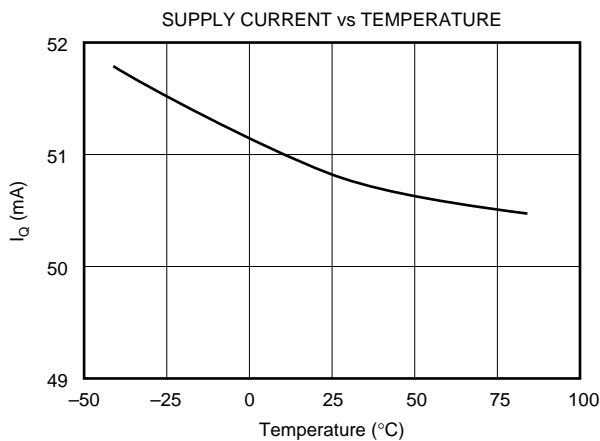
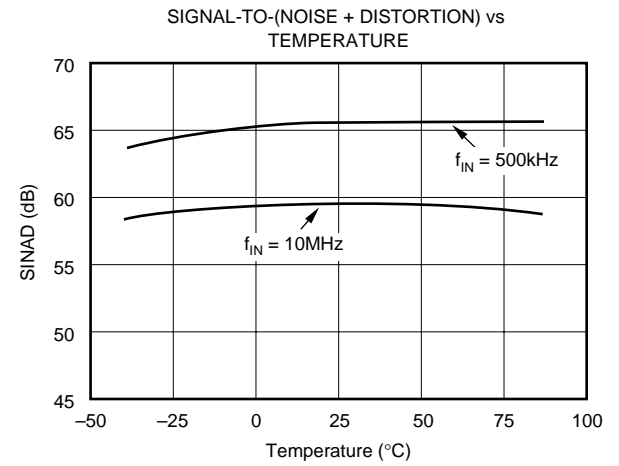
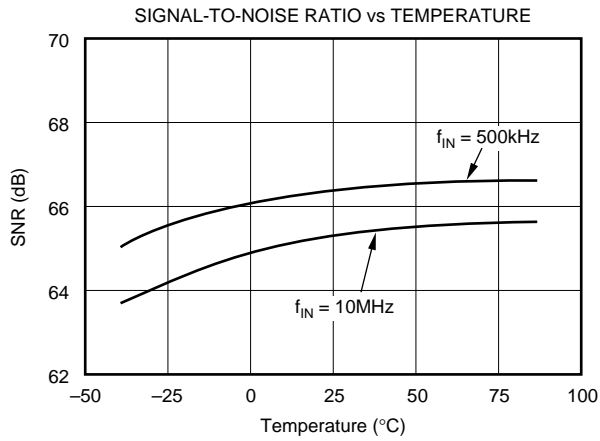
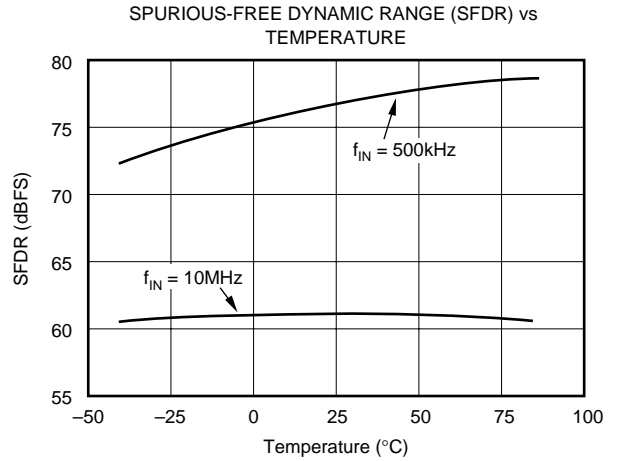
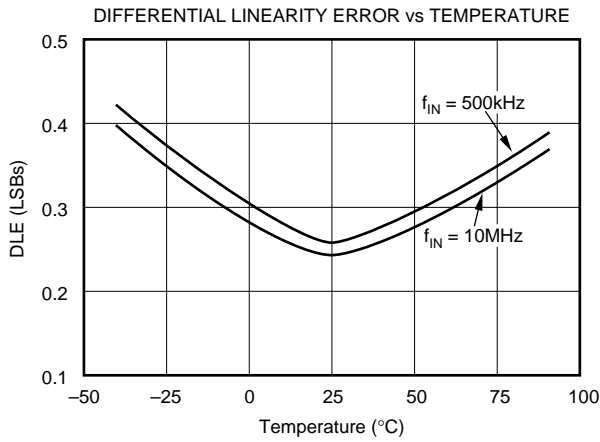

# TYPICAL CHARACTERISTICS (Cont.)

At  $T_A = +25^\circ\text{C}$ ,  $V_S = +5\text{V}$ , Sampling Rate = 25MHz, and with a 50% duty cycle clock having a 2ns rise-and-fall time, unless otherwise noted.

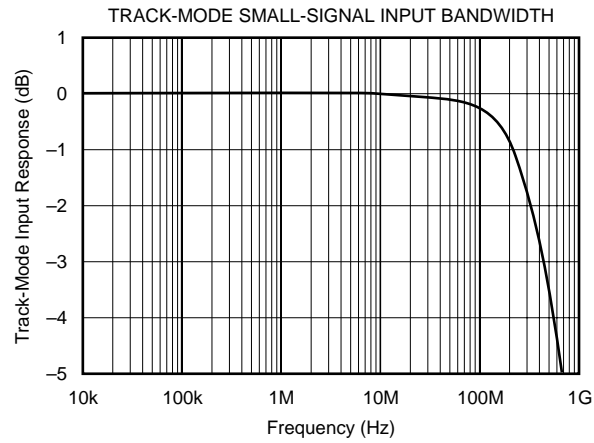
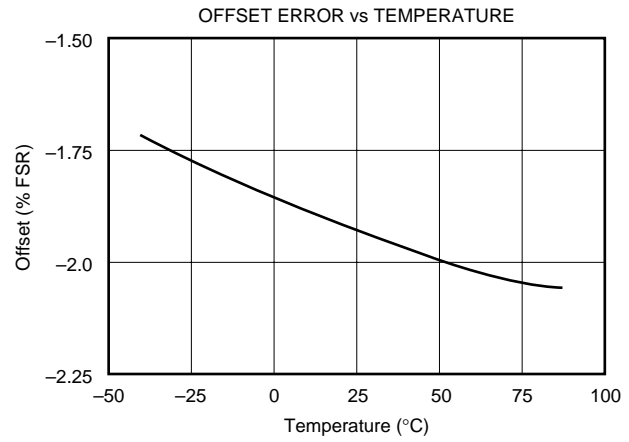
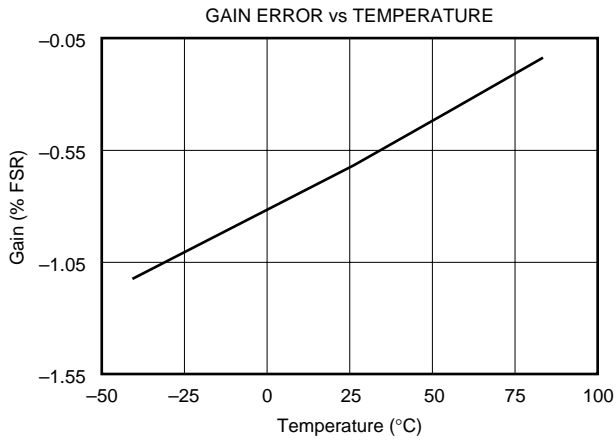

# THEORY OF OPERATION

The ADS801 is a high-speed, sampling A/D converter with pipelining. It uses a fully differential architecture and digital error correction to ensure 12-bit resolution. The differential track-and-hold circuit is shown in Figure 1. The switches are controlled by an internal clock that is a non-overlapping 2-phase signal,  $\phi_1$  and  $\phi_2$ . At the sampling time, the input signal is sampled on the bottom plates of the input capacitors. In the next clock phase,  $\phi_2$ , the bottom plates of the input capacitors are connected together and the feedback capacitors are switched to the op amp output. At this time, the charge redistributes between  $C_1$  and  $C_H$ , completing one track-and-hold cycle. The differential output is a held DC representation of the analog input at the sample time. The track-and-hold circuit can also convert a single-ended input signal into a fully differential signal for the quantizer.

The pipelined quantizer architecture has 11 stages with each stage containing a 2-bit quantizer and a 2-bit Digital-to-Analog Converter (DAC), as shown in Figure 2. Each 2-bit quantizer stage converts on the edge of the sub-clock, which is twice the frequency of the externally applied clock. The output of each quantizer is fed into its own delay line to time-

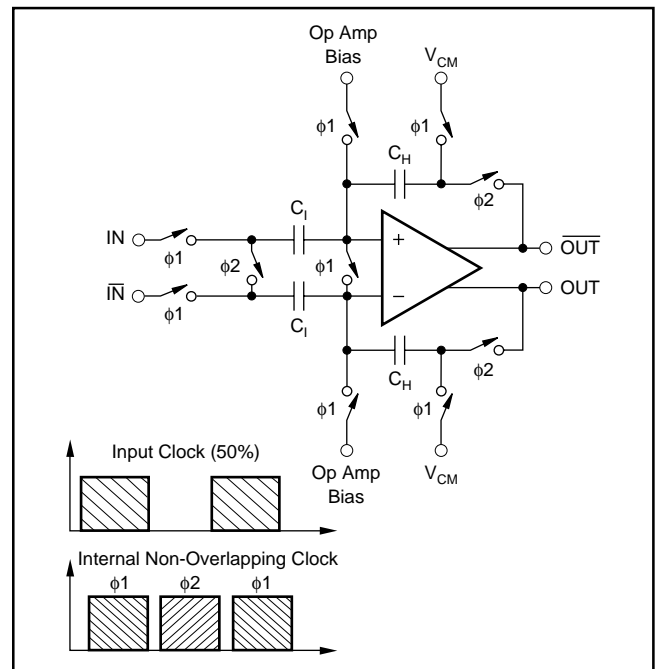

FIGURE 1. Input Track-and-Hold Configuration with Timing Signals.

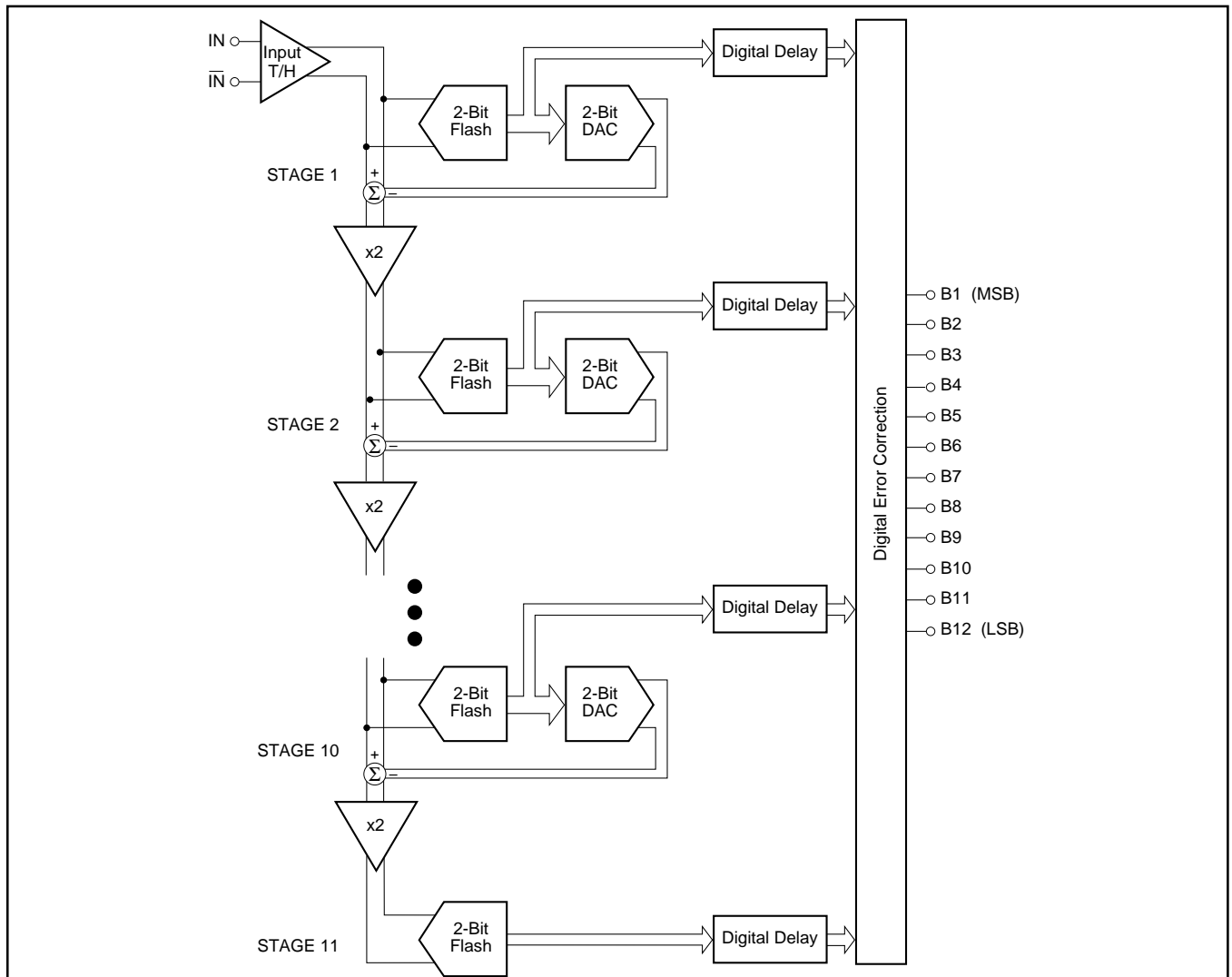

FIGURE 2. Pipeline A/D Converter Architecture.

align it with the data created from the following quantizer stages. This aligned data is fed into a digital error correction circuit that can adjust the output data based on the information found on the redundant bits. This technique gives the ADS801 excellent differential linearity and ensures no missing codes at the 12-bit level.

Since there are two pipeline stages per external clock cycle, there is a 6.5 clock cycle data latency from the start convert signal to the valid output data. The output data is available in Straight Offset Binary (SOB) or Binary Two's Complement (BTC) format.

### THE ANALOG INPUT AND INTERNAL REFERENCE

The analog input of the ADS801 can be configured in various ways and driven with different circuits, depending on the nature of the signal and the level of performance desired. The ADS801 has an internal reference that sets the full-scale input range of the A/D converter. The differential input range has each input centered around the common-mode of +2.25V, with each of the two inputs having a full-scale range of +1.25V to +3.25V. Since each input is 2Vp-p and 180° out-of-phase with the other, a 4V differential input signal to the quantizer results. As shown in Figure 3, the positive full-scale reference (REFT) and the negative full-scale (REFB) are brought out for external bypassing. In addition, the common-mode voltage (CM) may be used as a reference to provide the appropriate offset for the driving circuitry. However, care must be taken not to appreciably load this reference node. For more information regarding external references, single-ended input, and ADS801 drive circuits, refer to the applications section.

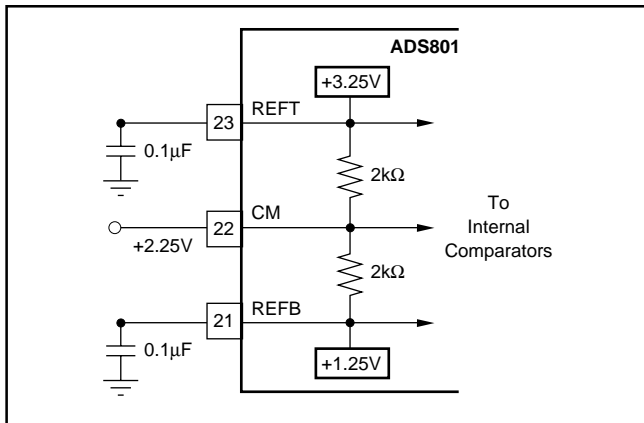

FIGURE 3. Internal Reference Structure.

### CLOCK REQUIREMENTS

The CLK pin accepts a CMOS level clock input. The rising and falling edges of the externally applied convert command clock controls the various interstage conversions in the pipeline. Therefore, the duty cycle of the clock should be held at 50% with low jitter and fast rise-and-fall times of 2ns or less. This is particularly important when digitizing a high-frequency input and operating at the maximum sample rate. Deviation from a 50% duty cycle will effectively shorten some of the interstage settling times, thus degrading the SNR and DNL performance.

### DIGITAL OUTPUT DATA

The 12-bit output data is provided at CMOS logic levels. The standard output coding is Straight Offset Binary (SOB) where a full-scale input signal corresponds to all “1s” at the output, as shown in Table I. This condition is met with pin 19 “LO” or Floating, due to an internal pull-down resistor. By applying a logic “HI” voltage to this pin, a Binary Two's Complement (BTC) output will be provided where the most significant bit is inverted. The digital outputs of the ADS801 can be set to a high-impedance state by driving  $\overline{OE}$  (pin 18) with a logic HIGH. Normal operation is achieved with pin 18 LOW or Floating, due to internal pull-down resistors. This function is provided for testability purposes and is not meant to drive digital buses directly or be dynamically changed during the conversion process.

DIFFERENTIAL INPUT <sup>(1)</sup>	OUTPUT CODE	
	SOB PIN 19 FLOATING or LOW	BTC PIN 19 HIGH
+FS (IN = +3.25V, $\overline{IN}$ = +1.25V)	111111111111	011111111111
+FS - 1LSB	111111111111	011111111111
+FS - 2LSB	111111111110	011111111110
+3/4 Full-Scale	111000000000	011000000000
+1/2 Full-Scale	110000000000	010000000000
+1/4 Full-Scale	101000000000	001000000000
+1LSB	100000000001	000000000001
Bipolar Zero (IN = $\overline{IN}$ = +2.25V)	100000000000	000000000000
-1LSB	011111111111	111111111111
-1/4 Full-Scale	011000000000	111000000000
-1/2 Full-Scale	010000000000	110000000000
-3/4 Full-Scale	001000000000	101000000000
-FS + 1LSB	000000000001	100000000001
-FS (IN = +1.25V, $\overline{IN}$ = +3.25V)	000000000000	100000000000

NOTE: (1) In the single-ended input mode, +FS = +4.25V and -FS = +0.25V.

TABLE I. Coding Table for the ADS801.

## APPLICATIONS

### DRIVING THE ADS801

The ADS801 has a differential input with a common-mode of +2.25V. For AC-coupled applications, the simplest way to create this differential input is to drive the primary winding of a transformer with a single-ended input. A differential output is created on the secondary if the center tap is tied to the common-mode voltage of +2.25V, as per Figure 4. This transformer-coupled input arrangement provides good high-

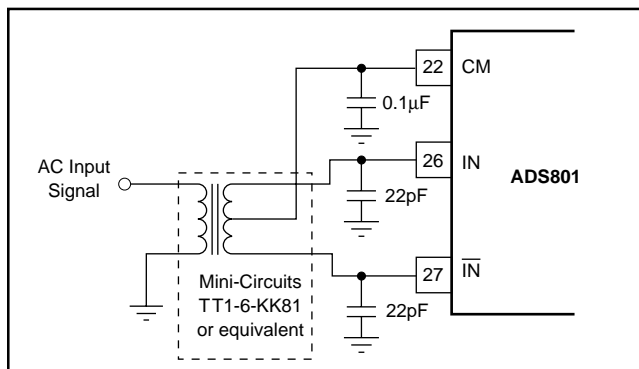

FIGURE 4. AC-Coupled Single-Ended to Differential Drive Circuit Using a Transformer.

frequency AC performance. It is important to select a transformer that gives low distortion and does not exhibit core saturation at full-scale voltage levels. Since the transformer does not appreciably load the ladder, there is no need to buffer the Common-Mode (CM) output in this instance. In general, it is advisable to keep the current draw from the CM output pin below  $0.5\mu\text{A}$  to avoid nonlinearity in the internal reference ladder. A FET input operational amplifier, such as the OPA130, can provide a buffered reference for driving external circuitry. The analog IN and  $\bar{\text{IN}}$  inputs should be bypassed with 22pF capacitors to minimize track-and-hold glitches and to improve high input frequency performance.

Figure 5 illustrates another possible low-cost interface circuit that utilizes resistors and capacitors in place of a transformer. Depending on the signal bandwidth, the component values should be carefully selected in order to maintain the product performance outlined. The input capacitors,  $C_{\text{IN}}$ , and the input resistors,  $R_{\text{IN}}$ , create a high-pass filter with the lower corner frequency at  $f_c = 1/(2\pi R_{\text{IN}}C_{\text{IN}})$ . The corner frequency can be reduced by either increasing the value of  $R_{\text{IN}}$  or  $C_{\text{IN}}$ . If the circuit operates with a  $50\Omega$  or  $75\Omega$  impedance level, the resistors are fixed and only the value of the capacitor can be increased. Usually AC-coupling capacitors are electrolytic or tantalum capacitors with values of  $1\mu\text{F}$  or higher. It should be noted that these large capacitors become inductive with increased input frequency, which could lead to signal amplitude errors or oscillation. To maintain a low AC-coupling impedance throughout the signal band, a small value (e.g.  $1\mu\text{F}$ ) ceramic capacitor could be added in parallel with the polarized capacitor.

Capacitors  $C_{\text{SH}1}$  and  $C_{\text{SH}2}$  are used to minimize current glitches resulting from the switching in the input track-and-hold stage and to improve signal-to-noise performance. These capacitors can also be used to establish a low-pass filter and effectively reduce the noise bandwidth. In order to create a real pole, resistors  $R_{\text{SER}1}$  and  $R_{\text{SER}2}$  were added in series with each input. The cutoff frequency of the filter is determined by  $f_c = 1/(2\pi R_{\text{SER}} \cdot (C_{\text{SH}} + C_{\text{ADC}}))$ , where  $R_{\text{SER}}$  is the resistor in

series with the input,  $C_{\text{SH}}$  is the external capacitor from the input to ground, and  $C_{\text{ADC}}$  is the internal input capacitance of the A/D converter (typically 4pF).

Resistors  $R_1$  and  $R_2$  are used to derive the necessary common-mode voltage from the buffered top and bottom references. The total load of the resistor string should be selected so that the current does not exceed 1mA. Although the circuit in Figure 5 uses two resistors of equal value so that the common-mode voltage is centered between the top and bottom reference ( $+2.25\text{V}$ ), it is not necessary to do so. In all cases the center point,  $V_{\text{CM}}$ , should be bypassed to ground in order to provide a low-impedance AC ground.

If the signal needs to be DC-coupled to the input of the ADS801, an operational amplifier input circuit is required. In the differential input mode, any single-ended signal must be modified to create a differential signal. This can be accomplished by using two operational amplifiers; one in the noninverting mode for the input and the other amplifier in the inverting mode for the complementary input. The low distortion circuit in Figure 6 will provide the necessary input shifting required for signals centered around ground. It also employs a diode for output level shifting to ensure a low distortion  $+3.25\text{V}$  output swing. Other amplifiers can be used in place of the OPA842s if the lowest distortion is not necessary. If output level shifting circuits are not used, care must be taken to select operational amplifiers that give the necessary performance when swinging to  $+3.25\text{V}$  with a  $\pm 5\text{V}$  supply operational amplifier.

The ADS801 can also be configured with a single-ended input full-scale range of  $+0.25\text{V}$  to  $+4.25\text{V}$  by tying the complementary input to the common-mode reference voltage (see Figure 7). This configuration will result in increased even-order harmonics, especially at higher input frequencies. However, this tradeoff may be quite acceptable for time-domain applications. The driving amplifier must give adequate performance with a  $+0.25\text{V}$  to  $+4.25\text{V}$  output swing in this case.

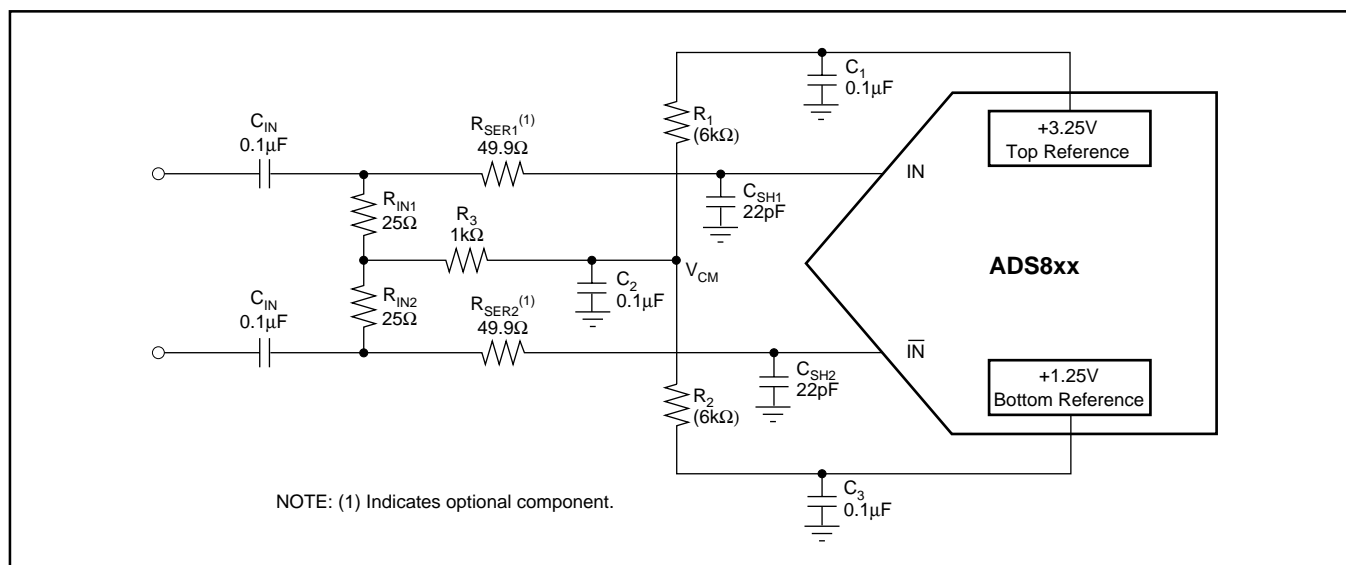

FIGURE 5. AC-Coupled Differential Input Circuit.

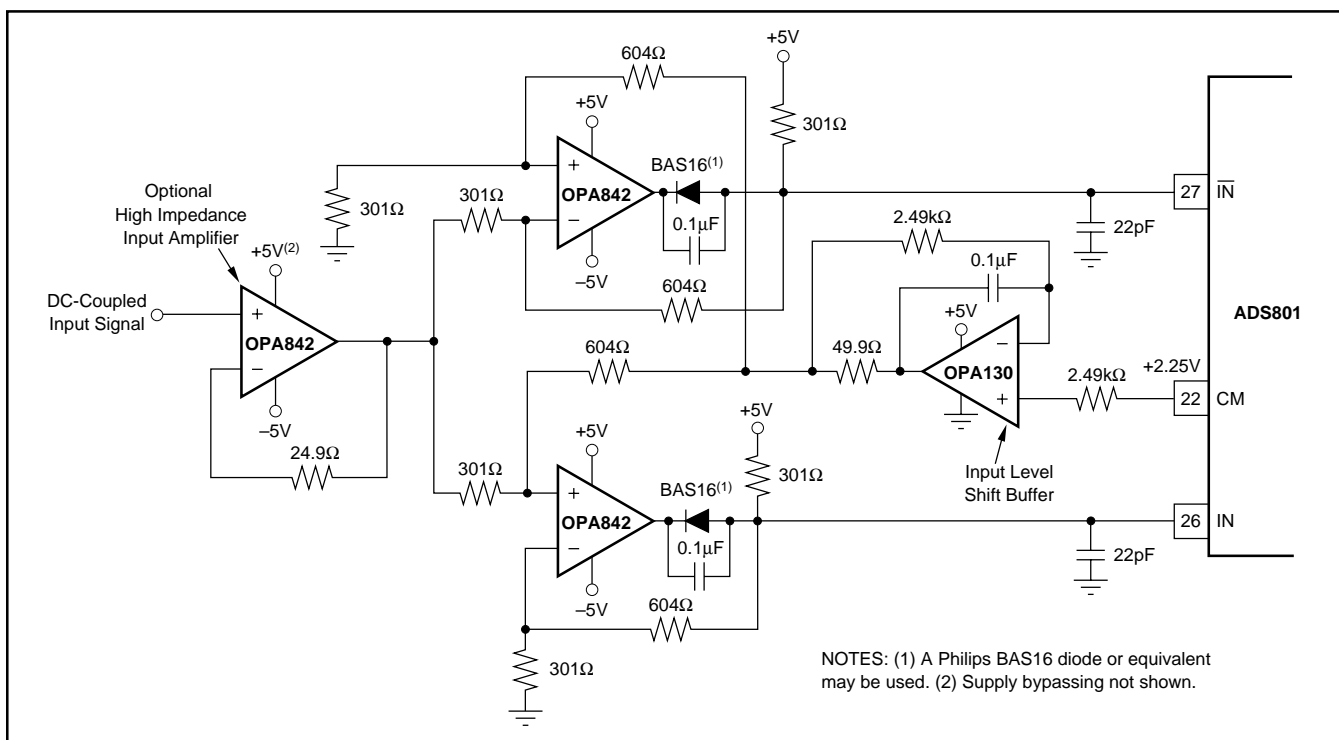

FIGURE 6. A Low-Distortion, DC-Coupled, Single-Ended to Differential Input Driver Circuit.

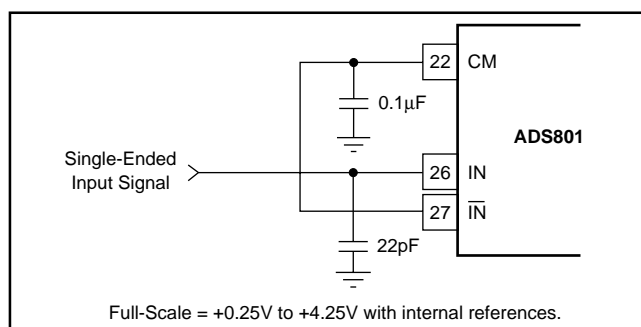

FIGURE 7. Single-Ended Input Connection.

## EXTERNAL REFERENCES AND ADJUSTMENT OF FULL-SCALE RANGE

The internal reference buffers are limited to approximately 1mA of output current. As a result, these internal +1.25V and +3.25V references may be overridden by external references that have at least 18mA (at room temperature) of output drive capability. In this instance, the common-mode voltage will be set halfway between the two references. This feature can be used to adjust the gain error, improve gain drift, or to change the full-scale input range of the ADS801. Changing the full-scale range to a lower value has the benefit of easing the swing requirements of external input amplifiers. The external references can vary as long as the value of the external top reference ( $REF_{T\_EXT}$ ) is less than or equal to +3.4V, the value of the external bottom reference ( $REF_{B\_EXT}$ ) is greater than or equal to +1.1V, and the difference between the external references are greater than or equal to 1.5V.

For the differential configuration, the full-scale input range will be set to the external reference values that are selected. For the single-ended mode, the input range is

$2 \cdot (REF_{T\_EXT} - REF_{B\_EXT})$ , with the common-mode being centered at  $(REF_{T\_EXT} + REF_{B\_EXT})/2$ . Refer to the typical characteristics for expected performance versus full-scale input range.

The circuit in Figure 8 works completely on a single +5V supply. As a reference element, it uses micro-power reference REF1004-2.5 that is set to a quiescent current of 0.1mA. Amplifier  $A_2$  is configured as a follower to buffer the +1.25V generated from the resistor divider. To provide the necessary current drive, a pull-down resistor ( $R_p$ ) is added.

Amplifier  $A_1$  is configured as an adjustable-gain stage, with a range of approximately 1 to 1.32. The pull-up resistor again relieves the op amp from providing the full current drive. The value of the pull-up, pull-down resistors is not critical and can be varied to optimize power consumption. The need for pull-up, pull-down resistors depends only on the drive capability of the selected drive amplifier, and thus can be omitted.

## PC-BOARD LAYOUT AND BYPASSING

A well-designed, clean pc-board layout will assure proper operation and clean spectral response. Proper grounding and bypassing, short lead lengths, and the use of ground planes are particularly important for high-frequency circuits. Multilayer pc-boards are recommended for best performance, but if carefully designed, a two-sided pc-board with large, heavy ground planes can give excellent results. It is recommended that the analog and digital ground pins of the ADS801 be connected directly to the analog ground plane. In our experience, this gives the most consistent results. The A/D converter power-supply commons should be tied together at the analog ground plane. Power supplies should be bypassed with 0.1μF ceramic capacitors as close to the pin as possible.

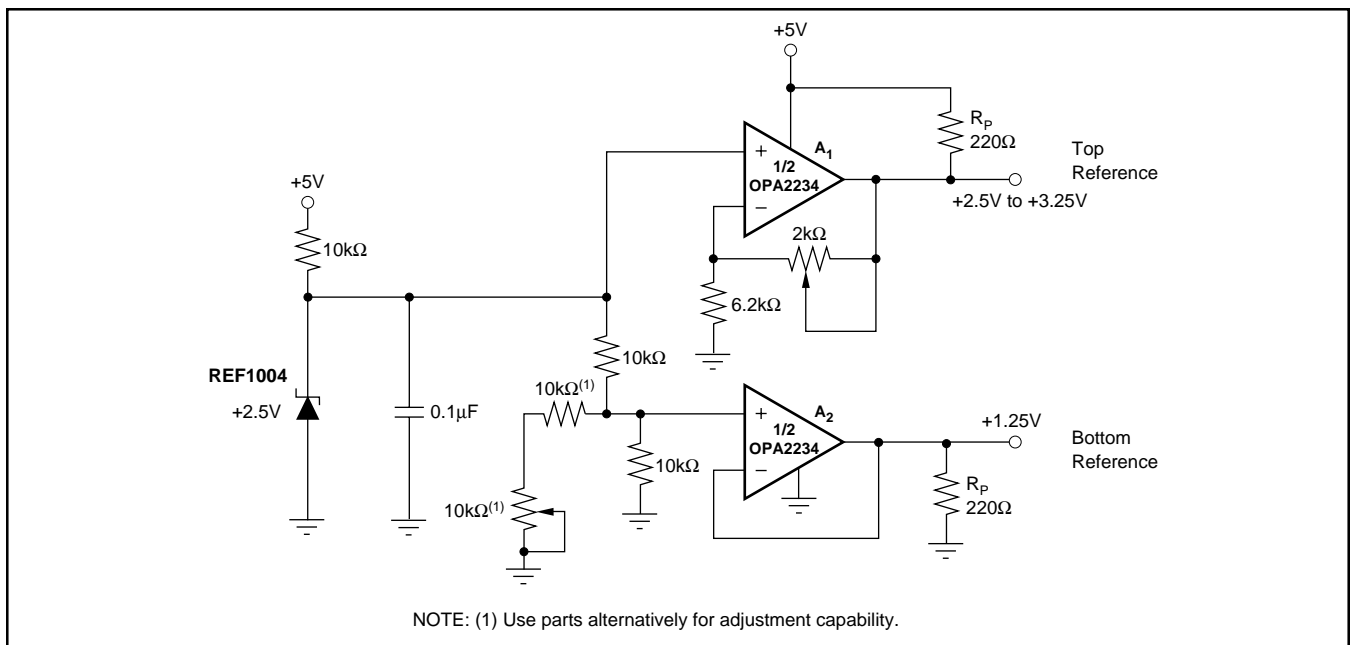

FIGURE 8. Optional External Reference to Set the Full-Scale Range Utilizing a Dual, Single-Supply Op Amp.

### DYNAMIC PERFORMANCE TESTING

The ADS801 is a high-performance converter and careful attention to test techniques is necessary to achieve accurate results. Highly accurate phase-locked signal sources allow high-resolution FFT measurements to be made without using data windowing functions. A low-jitter signal generator, such as the HP8644A for the test signal, phase-locked with a low-jitter HP8022A pulse generator for the A/D converter clock, gives excellent results. Low-pass filtering (or bandpass filtering) of test signals is absolutely necessary to test the low distortion of the ADS801. Using a signal amplitude slightly lower than full-scale will allow a small amount of “headroom” so that noise or DC-offset voltage will not overrange the A/D converter and cause clipping on signal peaks.

### DYNAMIC PERFORMANCE DEFINITIONS

1. Signal-to-Noise-and-Distortion Ratio (SINAD):
 
$$10 \log \frac{\text{Sinewave Signal Power}}{\text{Noise} + \text{Harmonic Power (first 15 harmonics)}}$$
2. Signal-to-Noise Ratio (SNR):
 
$$10 \log \frac{\text{Sinewave Signal Power}}{\text{Noise Power}}$$
3. Intermodulation Distortion (IMD):
 
$$10 \log \frac{\text{Highest IMD Product Power (to 5th - order)}}{\text{Sinewave Signal Power}}$$

IMD is referenced to the larger of the test signals  $f_1$  or  $f_2$ . Five “bins” either side of peak are used for calculation of fundamental and harmonic power. The “0” frequency bin (DC) is not included in these calculations, as it is of little importance in dynamic signal processing applications.

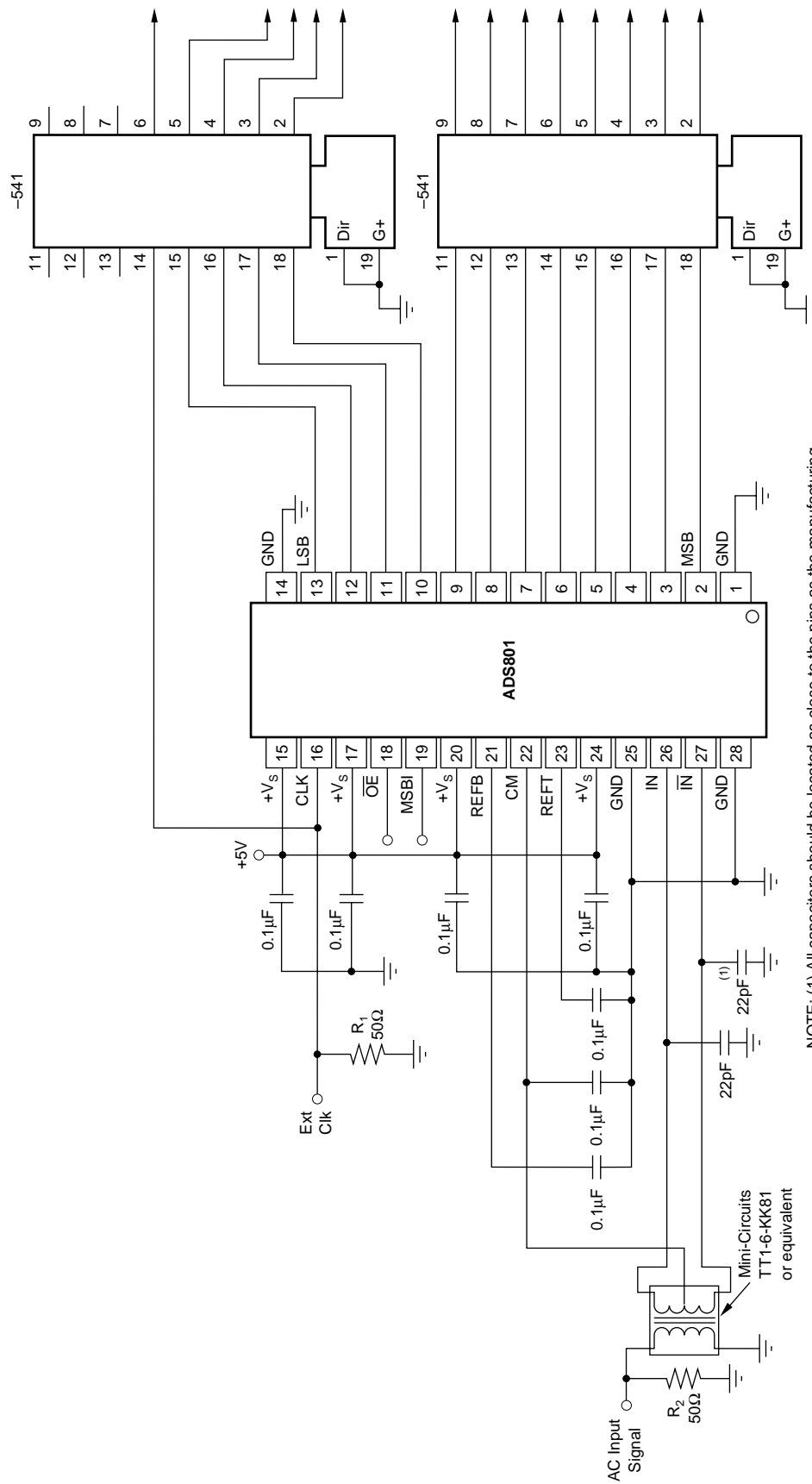

FIGURE 9. ADS801 Interface Schematic with AC-Coupling and External Buffers.

**PACKAGING INFORMATION**

Orderable Device	Status <sup>(1)</sup>	Package Type	Package Drawing	Pins	Package Qty	Eco Plan <sup>(2)</sup>	Lead/Ball Finish	MSL Peak Temp <sup>(3)</sup>	Samples (Requires Login)
ADS801E	OBSOLETE	SSOP	DB	28		TBD	Call TI	Call TI	
ADS801E/1K	OBSOLETE	SSOP	DB	28		TBD	Call TI	Call TI	
ADS801U	ACTIVE	SOIC	DW	28	20	Green (RoHS & no Sb/Br)	CU NIPDAU	Level-2-260C-1 YEAR	
ADS801UG4	ACTIVE	SOIC	DW	28	20	Green (RoHS & no Sb/Br)	CU NIPDAU	Level-2-260C-1 YEAR	

<sup>(1)</sup> The marketing status values are defined as follows:

**ACTIVE:** Product device recommended for new designs.

**LIFEBUY:** TI has announced that the device will be discontinued, and a lifetime-buy period is in effect.

**NRND:** Not recommended for new designs. Device is in production to support existing customers, but TI does not recommend using this part in a new design.

**PREVIEW:** Device has been announced but is not in production. Samples may or may not be available.

**OBSOLETE:** TI has discontinued the production of the device.

<sup>(2)</sup> Eco Plan - The planned eco-friendly classification: Pb-Free (RoHS), Pb-Free (RoHS Exempt), or Green (RoHS & no Sb/Br) - please check <http://www.ti.com/productcontent> for the latest availability information and additional product content details.

**TBD:** The Pb-Free/Green conversion plan has not been defined.

**Pb-Free (RoHS):** TI's terms "Lead-Free" or "Pb-Free" mean semiconductor products that are compatible with the current RoHS requirements for all 6 substances, including the requirement that lead not exceed 0.1% by weight in homogeneous materials. Where designed to be soldered at high temperatures, TI Pb-Free products are suitable for use in specified lead-free processes.

**Pb-Free (RoHS Exempt):** This component has a RoHS exemption for either 1) lead-based flip-chip solder bumps used between the die and package, or 2) lead-based die adhesive used between the die and leadframe. The component is otherwise considered Pb-Free (RoHS compatible) as defined above.

**Green (RoHS & no Sb/Br):** TI defines "Green" to mean Pb-Free (RoHS compatible), and free of Bromine (Br) and Antimony (Sb) based flame retardants (Br or Sb do not exceed 0.1% by weight in homogeneous material)

<sup>(3)</sup> MSL, Peak Temp. -- The Moisture Sensitivity Level rating according to the JEDEC industry standard classifications, and peak solder temperature.

**Important Information and Disclaimer:** The information provided on this page represents TI's knowledge and belief as of the date that it is provided. TI bases its knowledge and belief on information provided by third parties, and makes no representation or warranty as to the accuracy of such information. Efforts are underway to better integrate information from third parties. TI has taken and continues to take reasonable steps to provide representative and accurate information but may not have conducted destructive testing or chemical analysis on incoming materials and chemicals. TI and TI suppliers consider certain information to be proprietary, and thus CAS numbers and other limited information may not be available for release.

In no event shall TI's liability arising out of such information exceed the total purchase price of the TI part(s) at issue in this document sold by TI to Customer on an annual basis.

DW (R-PDSO-G28)

PLASTIC SMALL OUTLINE

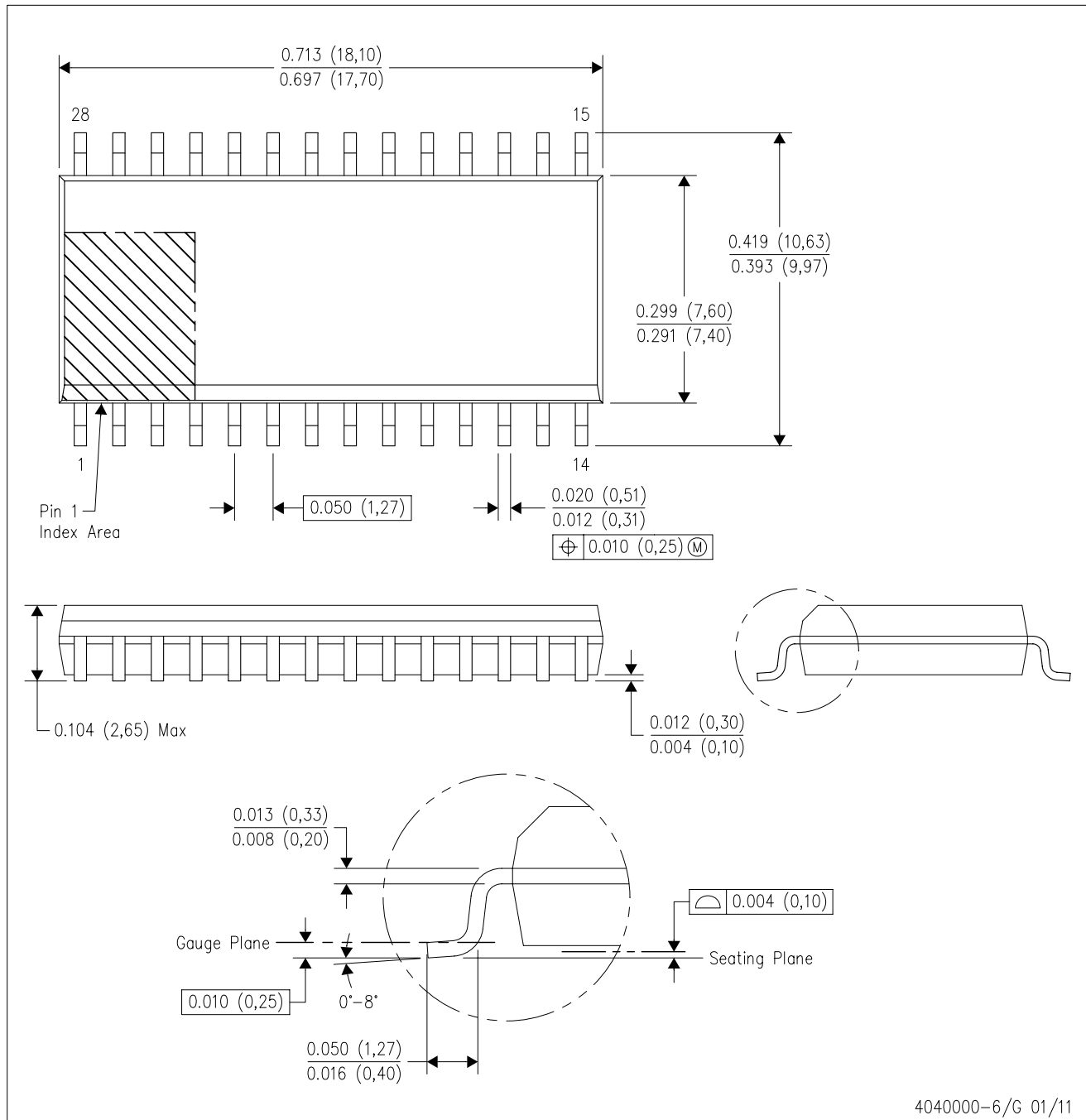

- NOTES:
- All linear dimensions are in inches (millimeters). Dimensioning and tolerancing per ASME Y14.5M-1994.
  - This drawing is subject to change without notice.
  - Body dimensions do not include mold flash or protrusion not to exceed 0.006 (0,15).
  - Falls within JEDEC MS-013 variation AE.

DW (R-PDSO-G28)

PLASTIC SMALL OUTLINE

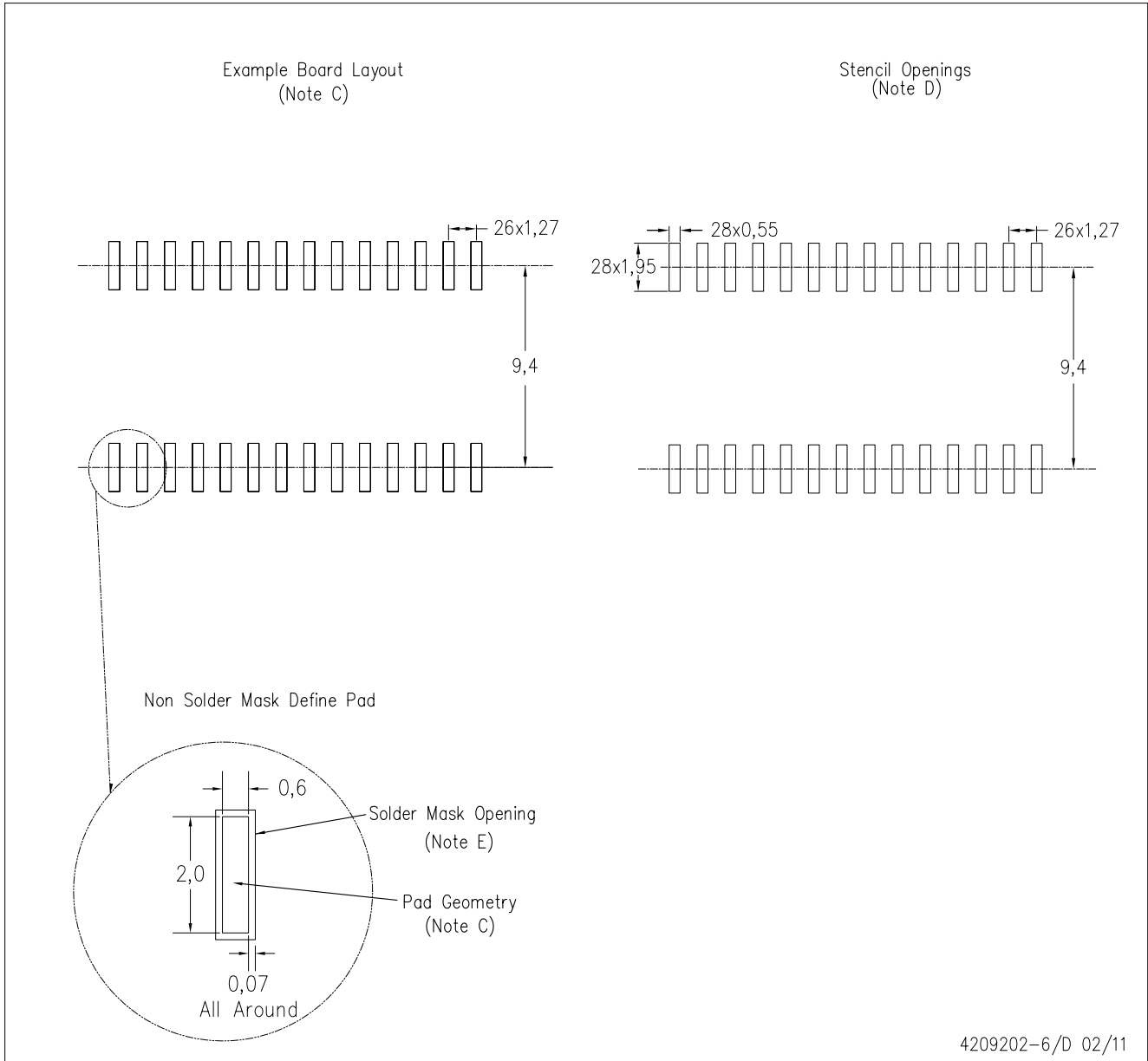

- NOTES:
- A. All linear dimensions are in millimeters.
  - B. This drawing is subject to change without notice.
  - C. Refer to IPC7351 for alternate board design.
  - D. Laser cutting apertures with trapezoidal walls and also rounding corners will offer better paste release. Customers should contact their board assembly site for stencil design recommendations. Refer to IPC-7525
  - E. Customers should contact their board fabrication site for solder mask tolerances between and around signal pads.

DB (R-PDSO-G\*\*)

PLASTIC SMALL-OUTLINE

28 PINS SHOWN



- NOTES: A. All linear dimensions are in millimeters.  
 B. This drawing is subject to change without notice.  
 C. Body dimensions do not include mold flash or protrusion not to exceed 0,15.  
 D. Falls within JEDEC MO-150

## IMPORTANT NOTICE

Texas Instruments Incorporated and its subsidiaries (TI) reserve the right to make corrections, modifications, enhancements, improvements, and other changes to its products and services at any time and to discontinue any product or service without notice. Customers should obtain the latest relevant information before placing orders and should verify that such information is current and complete. All products are sold subject to TI's terms and conditions of sale supplied at the time of order acknowledgment.

TI warrants performance of its hardware products to the specifications applicable at the time of sale in accordance with TI's standard warranty. Testing and other quality control techniques are used to the extent TI deems necessary to support this warranty. Except where mandated by government requirements, testing of all parameters of each product is not necessarily performed.

TI assumes no liability for applications assistance or customer product design. Customers are responsible for their products and applications using TI components. To minimize the risks associated with customer products and applications, customers should provide adequate design and operating safeguards.

TI does not warrant or represent that any license, either express or implied, is granted under any TI patent right, copyright, mask work right, or other TI intellectual property right relating to any combination, machine, or process in which TI products or services are used. Information published by TI regarding third-party products or services does not constitute a license from TI to use such products or services or a warranty or endorsement thereof. Use of such information may require a license from a third party under the patents or other intellectual property of the third party, or a license from TI under the patents or other intellectual property of TI.

Reproduction of TI information in TI data books or data sheets is permissible only if reproduction is without alteration and is accompanied by all associated warranties, conditions, limitations, and notices. Reproduction of this information with alteration is an unfair and deceptive business practice. TI is not responsible or liable for such altered documentation. Information of third parties may be subject to additional restrictions.

Resale of TI products or services with statements different from or beyond the parameters stated by TI for that product or service voids all express and any implied warranties for the associated TI product or service and is an unfair and deceptive business practice. TI is not responsible or liable for any such statements.

TI products are not authorized for use in safety-critical applications (such as life support) where a failure of the TI product would reasonably be expected to cause severe personal injury or death, unless officers of the parties have executed an agreement specifically governing such use. Buyers represent that they have all necessary expertise in the safety and regulatory ramifications of their applications, and acknowledge and agree that they are solely responsible for all legal, regulatory and safety-related requirements concerning their products and any use of TI products in such safety-critical applications, notwithstanding any applications-related information or support that may be provided by TI. Further, Buyers must fully indemnify TI and its representatives against any damages arising out of the use of TI products in such safety-critical applications.

TI products are neither designed nor intended for use in military/aerospace applications or environments unless the TI products are specifically designated by TI as military-grade or "enhanced plastic." Only products designated by TI as military-grade meet military specifications. Buyers acknowledge and agree that any such use of TI products which TI has not designated as military-grade is solely at the Buyer's risk, and that they are solely responsible for compliance with all legal and regulatory requirements in connection with such use.

TI products are neither designed nor intended for use in automotive applications or environments unless the specific TI products are designated by TI as compliant with ISO/TS 16949 requirements. Buyers acknowledge and agree that, if they use any non-designated products in automotive applications, TI will not be responsible for any failure to meet such requirements.

Following are URLs where you can obtain information on other Texas Instruments products and application solutions:

### Products

Audio	<a href="http://www.ti.com/audio">www.ti.com/audio</a>
Amplifiers	<a href="http://amplifier.ti.com">amplifier.ti.com</a>
Data Converters	<a href="http://dataconverter.ti.com">dataconverter.ti.com</a>
DLP® Products	<a href="http://www.dlp.com">www.dlp.com</a>
DSP	<a href="http://dsp.ti.com">dsp.ti.com</a>
Clocks and Timers	<a href="http://www.ti.com/clocks">www.ti.com/clocks</a>
Interface	<a href="http://interface.ti.com">interface.ti.com</a>
Logic	<a href="http://logic.ti.com">logic.ti.com</a>
Power Mgmt	<a href="http://power.ti.com">power.ti.com</a>
Microcontrollers	<a href="http://microcontroller.ti.com">microcontroller.ti.com</a>
RFID	<a href="http://www.ti-rfid.com">www.ti-rfid.com</a>
RF/IF and ZigBee® Solutions	<a href="http://www.ti.com/lprf">www.ti.com/lprf</a>

### Applications

Communications and Telecom	<a href="http://www.ti.com/communications">www.ti.com/communications</a>
Computers and Peripherals	<a href="http://www.ti.com/computers">www.ti.com/computers</a>
Consumer Electronics	<a href="http://www.ti.com/consumer-apps">www.ti.com/consumer-apps</a>
Energy and Lighting	<a href="http://www.ti.com/energy">www.ti.com/energy</a>
Industrial	<a href="http://www.ti.com/industrial">www.ti.com/industrial</a>
Medical	<a href="http://www.ti.com/medical">www.ti.com/medical</a>
Security	<a href="http://www.ti.com/security">www.ti.com/security</a>
Space, Avionics and Defense	<a href="http://www.ti.com/space-avionics-defense">www.ti.com/space-avionics-defense</a>
Transportation and Automotive	<a href="http://www.ti.com/automotive">www.ti.com/automotive</a>
Video and Imaging	<a href="http://www.ti.com/video">www.ti.com/video</a>
Wireless	<a href="http://www.ti.com/wireless-apps">www.ti.com/wireless-apps</a>

TI E2E Community Home Page

[e2e.ti.com](http://e2e.ti.com)

Mailing Address: Texas Instruments, Post Office Box 655303, Dallas, Texas 75265  
Copyright © 2011, Texas Instruments Incorporated