

TV SAT IF-FM-Demodulator

TDA 6140-5X

Preliminary Data

Bipolar IC

Features

- Input sensitivity approx. -40 dBm
- Symmetrical, low impedance IF-Input
- Two AFC-Outputs for up and down direction of tuning
- AFC-offset adjustable by an external control voltage
- Reduced external components



P-DSO-16-1

Type

TDA 6140-5X

Ordering Code

Q67000-A5172

Package

P-DSO-16-1 (SMD)

Amplifier and IF demodulator for satellite applications, consisting of: two-stage limiter amplifier; divider by 4; video amplifier; AGC; AFC-stage; reverse polarity switch for video signals.

Pin Configuration
(top view)

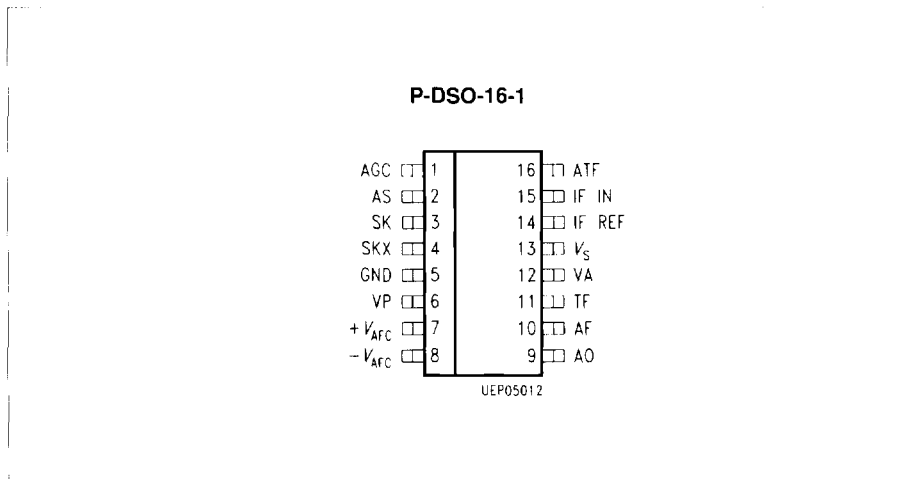

Pin Definitions and Functions

Pin No.	Symbol	Function
1	AGC	AGC-control voltage output
2	AS	AGC-threshold adjust
3	SK	Demodulator tank circuit
4	SK	Demodulator tank circuit
5	GND	Ground
6	VP	Video polarity switch input for positive or negative modulation
7	+ V _{AFC}	Output for AFC-control (up)
8	- V _{AFC}	Output for AFC-control (down)
9	AO	External AFC-offset voltage input
10	AF	AFC-window width-adjust
11	TF	AFC-lowpass filter
12	VA	Video output
13	V _S	Supply voltage
14	IFREF	IF-reference input
15	IFIN	IF-input
16	ATF	AGC-lowpass filter

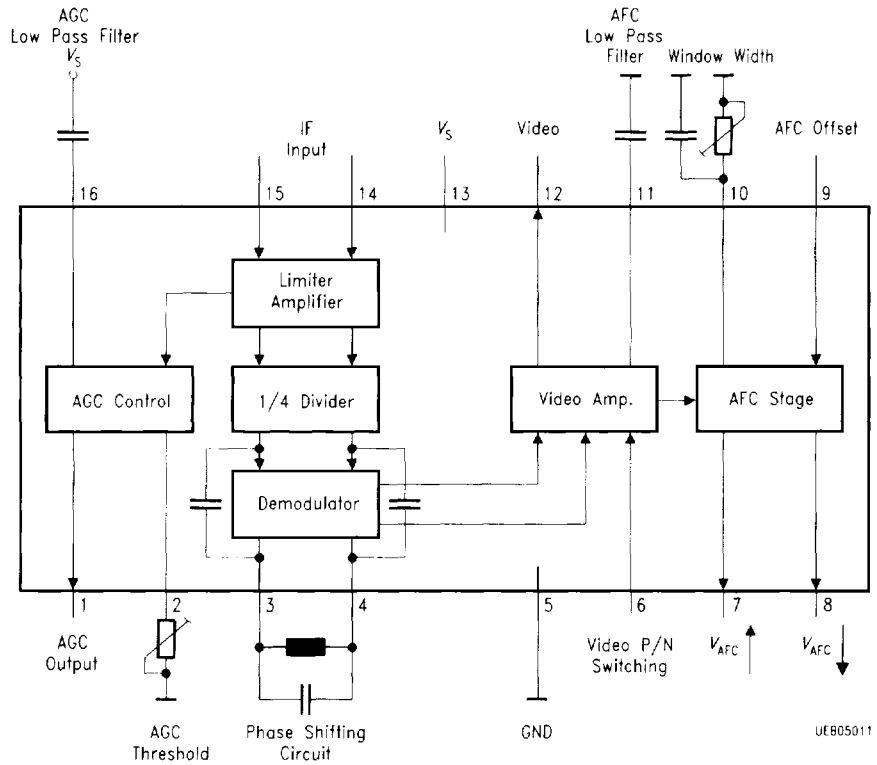

Block Diagram

Circuit Description

By capacitive coupling, the FM modulated satellite IF-signal is fed into the input of a symmetrical limiter amplifier. Asymmetrical operation of this limiter amplifier is also possible, if one of the two inputs is blocked against high frequency signals. The output signal of the amplifier is divided by four and sent directly as well as phase shifted to the quadrature demodulator. The phase shifting is done using an external LC tank circuit. The demodulated video signal is amplified and available on the video output.

The AFC stage detects frequency offsets. The output signals of the AFC stage are available at the AFC "up" and AFC "down" control pins as an information to be processed in a microprocessor. A channel-dependent offset of the AFC curve can be adjusted by an external DC-voltage applied to the "AFC offset voltage" input pin. The AFC window width can be adjusted in the range of 0.5 to 1.5 MHz by means of an external resistance.

The information for the field strength of the FM modulated IF satellite signal is available as a DC voltage at the AGC-output. The AGC-threshold can be adjusted by a potentiometer.

The polarity of the demodulated video signal can be inverted by an external switching voltage fed into the polarity switch input pin (positive or negative modulation).

Absolute Maximum Ratings

$T_A = 0$ to 70 °C

Parameter	Symbol	Limit Values		Unit	Test Condition
		min.	max.		
Supply voltage	V_S	0	6	V	
AGC-control voltage output	V_1	1	13	V	Open collector
AGC-threshold input	V_2	0.3	2	V	
Demodulator LC-circuit input	$V_{3,4}$	-0.3	3	V	
Video P/N-switching	V_6	-0.3	6	V	
AFC-control	$V_{7,B}$	0	6	V	Open collector
AFC-offset input	V_9	0	5	V	
AFC-window width	V_{10}	0.3	2	V	
AFC-lowpass filter	V_{11}	0	5	V	
Video output	V_{12}	1	5	V	
IF-inputs	$V_{14,15}$	-0.3	3	V	
AGC-lowpass filter	V_{16}	-0.3	5	V	
Junction temperature	T_j		150	°C	
Storage temperature	T_{stg}	-40	125	°C	
Thermal resistance	$R_{th SA}$		125	K/W	

Operating Range

Supply voltage	V_S	4.5	5.5	V
Input frequency range	f_{15}	300	900	MHz
Ambient temperature during operation	T_A	0	70	°C

Characteristics

$T_A = 25\text{ }^\circ\text{C}$; $V_S = 5\text{ V}$ (test circuit 1)

Parameter	Symbol	Limit Values			Unit	Test Condition
		min.	typ.	max.		
Power consumption	I_S	30	40	50	mA	

Static Specifications

Input Sensitivity

IF-input	a_{15}	-40		3	dBm	$f_{15} = 480\text{ MHz}$
Input impedance	$R_{14,15}$		500		Ω	Parallel equivalent circuit
	$C_{14,15}$		1.3		pF	Parallel equivalent circuit

Video Output

Voltage (Frequency deviation $\Delta f = 13.5\text{ MHz}$)	V_{12}	300		700	mV	
Distortion factor	THD		< 1		%	
Signal/noise ratio	S/N		70		dB	

Video P/N-Switching

Positive polarity	V_6	3.5			V	
Input current	I_{6H}			50	μA	
Negative polarity	V_6			1	V	
Input current	I_{6L}			-50	μA	

AGC-Current (Open-collector current limited)

$a_{15} = -22\text{ dBm}$	I_1		10		μA	$V_1 = 8\text{ V}$; Pin 2 on ground
$a_{15} = -8\text{ dBm}$	I_1		500		μA	$V_1 = 8\text{ V}$; Pin 2 on ground

AFC-Control (Open-collector current limited)

$f_{15} = 480\text{ MHz}$	$V_{7,8}$		0.5		V	$R_{AFC} = \infty$
$f_{15} = 480\text{ MHz}$ +200 kHz	V_7		V_S -0.5		V	$R_{AFC} = \infty$ ($V_8 = \text{Low}$)
$f_{15} = 480\text{ MHz}$ -200 kHz	V_8		V_S -0.5		V	$R_{AFC} = \infty$ ($V_7 = \text{Low}$)

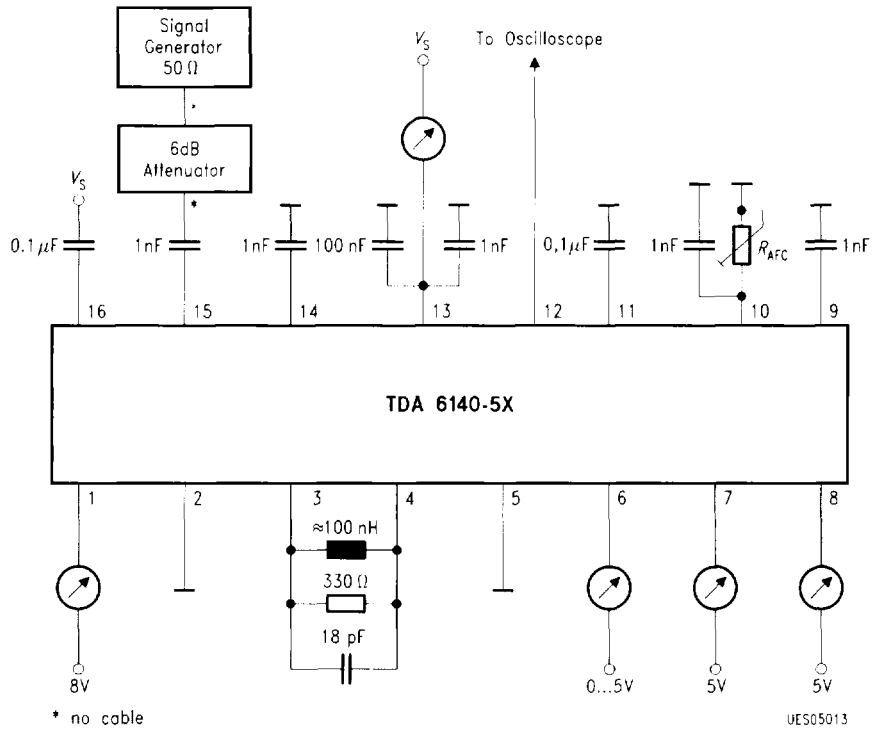

Test Circuit 1

