

T-43-21



# 100307 Low Power Quint Exclusive OR/NOR Gate

## General Description

The 100307 is monolithic quint exclusive-OR/NOR gate. The Function output is the wire-OR of all five exclusive-OR outputs. All inputs have 50 kΩ pull-down resistors.

## Features

- Low Power Operation
- 2000V ESD protection
- Pin/function compatible with 100107
- Voltage compensated operating range = -4.2V to -5.7V
- Available to industrial grade temperature range
- Available to MIL-STD-883

**Ordering Code:** See Section 6

## Logic Symbol

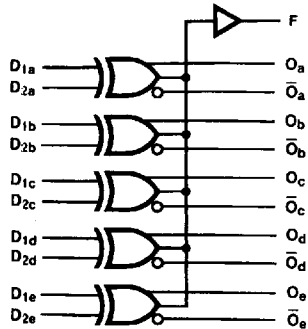

## Logic Equation

$$F = (D_{1a} \oplus D_{2a}) + (D_{1b} \oplus D_{2b}) + (D_{1c} \oplus D_{2c}) + (D_{1d} \oplus D_{2d}) + (D_{1e} \oplus D_{2e})$$

Pin Names	Description
D <sub>na</sub> -D <sub>ne</sub>	Data Inputs
F	Function Output
O <sub>a</sub> -O <sub>e</sub>	Data Outputs
O <sub>a</sub> -O <sub>e</sub>	Complementary Data Outputs

## Connection Diagrams

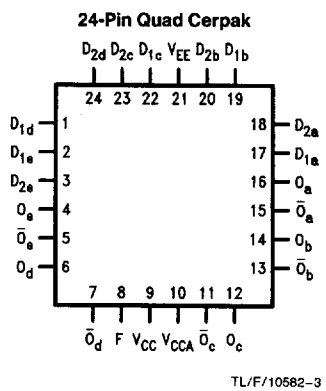
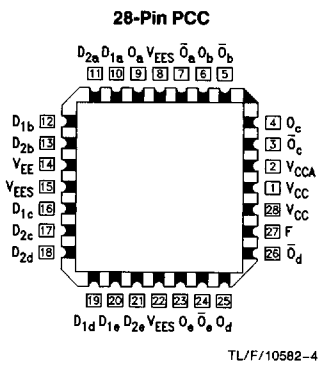
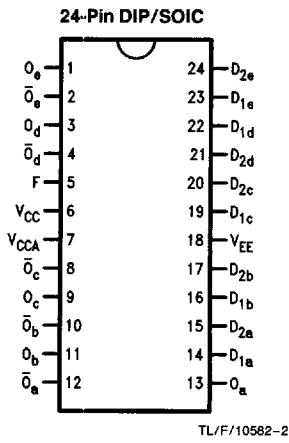

109307

### Absolute Maximum Ratings

Above which the useful life may be impaired. (Note 1)

If Military/Aerospace specified devices are required, please contact the National Semiconductor Sales Office/Distributors for availability and specifications.

Storage Temperature (T<sub>STG</sub>) -65°C to +150°C

Maximum Junction Temperature (T<sub>J</sub>)  
 Ceramic +175°C  
 Plastic +150°C

V<sub>EE</sub> Pin Potential to Ground Pin -7.0V to +0.5V

Input Voltage (DC) V<sub>EE</sub> to +0.5V

Output Current (DC Output HIGH) -50 mA

ESD (Note 2) ≥2000V

**Note 1:** Absolute maximum ratings are those values beyond which the device may be damaged or have its useful life impaired. Functional operation under these conditions is not implied.

**Note 2:** ESD testing conforms to MIL-STD-883, Method 3015.

### Recommended Operating Conditions

Case Temperature (T<sub>C</sub>)

Commercial 0°C to +85°C  
 Industrial -40°C to +85°C  
 Military -55°C to +125°C

Supply Voltage (V<sub>EE</sub>)

-5.7V to -4.2V

### Commercial Version

### DC Electrical Characteristics

V<sub>EE</sub> = -4.2V to -5.7V, V<sub>CC</sub> = V<sub>CCA</sub> = GND, T<sub>C</sub> = 0°C to +85°C (Note 3)

Symbol	Parameter	Min	Typ	Max	Units	Conditions	
V <sub>OH</sub>	Output HIGH Voltage	-1025	-955	-870	mV	V <sub>IN</sub> = V <sub>IH</sub> (Max) or V <sub>IL</sub> (Min)	Loading with 50Ω to -2.0V
V <sub>OL</sub>	Output LOW Voltage	-1830	-1705	-1620	mV		
V <sub>OHC</sub>	Output HIGH Voltage	-1035			mV	V <sub>IN</sub> = V <sub>IH</sub> (Min) or V <sub>IL</sub> (Max)	Loading with 50Ω to -2.0V
V <sub>OLC</sub>	Output LOW Voltage			-1610	mV		
V <sub>IH</sub>	Input HIGH Voltage	-1165		-870	mV	Guaranteed HIGH Signal for All Inputs	
V <sub>IL</sub>	Input LOW Voltage	-1830		-1475	mV	Guaranteed LOW Signal for All Inputs	
I <sub>IL</sub>	Input LOW Current	0.50			μA	V <sub>IN</sub> = V <sub>IL</sub> (Min)	
I <sub>IH</sub>	Input HIGH Current D <sub>2a</sub> -D <sub>2e</sub> D <sub>1a</sub> -D <sub>1e</sub>			250 350	μA	V <sub>IN</sub> = V <sub>IH</sub> (Max)	
I <sub>EE</sub>	Power Supply Current	-69	-43	-30	mA	Inputs Open	

**Note 3:** The specified limits represent the "worst case" value for the parameter. Since these values normally occur at the temperature extremes, additional noise immunity and guardbanding can be achieved by decreasing the allowable system operating ranges. Conditions for testing shown in the tables are chosen to guarantee operation under "worst case" conditions.

### DIP AC Electrical Characteristics

V<sub>EE</sub> = -4.2V to -5.7V, V<sub>CC</sub> = V<sub>CCA</sub> = GND

Symbol	Parameter	T <sub>C</sub> = 0°C		T <sub>C</sub> = +25°C		T <sub>C</sub> = +85°C		Units	Conditions
		Min	Max	Min	Max	Min	Max		
t <sub>PLH</sub> t <sub>PHL</sub>	Propagation Delay D <sub>2a</sub> -D <sub>2e</sub> to 0, $\bar{0}$	0.55	1.90	0.55	1.80	0.55	1.90	ns	Figures 1 and 2
t <sub>PLH</sub> t <sub>PHL</sub>	Propagation Delay D <sub>1a</sub> -D <sub>1e</sub> to 0, $\bar{0}$	0.55	1.70	0.55	1.60	0.55	1.70	ns	
t <sub>PLH</sub> t <sub>PHL</sub>	Propagation Delay Data to F	1.15	2.75	1.15	2.75	1.15	3.00	ns	
t <sub>TLH</sub> t <sub>THL</sub>	Transition Time 20% to 80%, 80% to 20%	0.35	1.20	0.35	1.20	0.35	1.20	ns	

**Commercial Version** (Continued)

**SOIC, PCC and Cerpak AC Electrical Characteristics**

$V_{EE} = -4.2V$  to  $-5.7V$ ,  $V_{CC} = V_{CCA} = GND$

Symbol	Parameter	$T_C = 0^\circ C$		$T_C = +25^\circ C$		$T_C = +85^\circ C$		Units	Conditions
		Min	Max	Min	Max	Min	Max		
$t_{PLH}$ $t_{PHL}$	Propagation Delay $D_{2a}-D_{2e}$ to O, $\bar{O}$	0.55	1.70	0.55	1.60	0.55	1.70	ns	Figures 1 and 2
$t_{PLH}$ $t_{PHL}$	Propagation Delay $D_{1a}-D_{1e}$ to O, $\bar{O}$	0.55	1.50	0.55	1.40	0.55	1.50	ns	
$t_{PLH}$ $t_{PHL}$	Propagation Delay Data to F	1.15	2.55	1.15	2.55	1.15	2.80	ns	
$t_{TLH}$ $t_{THL}$	Transition Time 20% to 80%, 80% to 20%	0.35	1.10	0.35	1.10	0.35	1.10	ns	

**Industrial Version**

**PCC DC Electrical Characteristics**

$V_{EE} = -4.2V$  to  $-5.7V$ ,  $V_{CC} = V_{CCA} = GND$ ,  $T_C = -40^\circ C$  to  $+85^\circ C$  (Note 1)

Symbol	Parameter	$T_C = -40^\circ C$		$T_C = 0^\circ C$ to $+85^\circ C$		Units	Conditions	
		Min	Max	Min	Max			
$V_{OH}$	Output HIGH Voltage	-1085	-870	-1025	-870	mV	$V_{IN} = V_{IH(Max)}$ or $V_{IL(Min)}$	Loading with $50\Omega$ to $-2.0V$
$V_{OL}$	Output LOW Voltage	-1830	-1575	-1830	-1620	mV		
$V_{OHC}$	Output HIGH Voltage	-1095		-1035		mV	$V_{IN} = V_{IH(Min)}$ or $V_{IL(Max)}$	Loading with $50\Omega$ to $-2.0V$
$V_{OLC}$	Output LOW Voltage		-1565		-1610	mV		
$V_{IH}$	Input HIGH Voltage	-1170	-870	-1165	-870	mV	Guaranteed HIGH Signal for All Inputs	
$V_{IL}$	Input LOW Voltage	-1830	-1480	-1830	-1475	mV	Guaranteed LOW Signal for All Inputs	
$I_{IL}$	Input LOW Current	0.50		0.50		$\mu A$	$V_{IN} = V_{IL(Min)}$	
$I_{IH}$	Input HIGH Current $D_{2a}-D_{2e}$ $D_{1a}-D_{1e}$		250 350		250 350	$\mu A$	$V_{IN} = V_{IH(Max)}$	
$I_{EE}$	Power Supply Current	-69	-30	-69	-30	mA	Inputs Open	

**Note 1:** The specified limits represent the "worst case" value for the parameter. Since these values normally occur at the temperature extremes, additional noise immunity and guardbanding can be achieved by decreasing the allowable system operating ranges. Conditions for testing shown in the tables are chosen to guarantee operation under "worst case" conditions.

100307

**Industrial Version** (Continued)

**PCC AC Electrical Characteristics**

$V_{EE} = -4.2V$  to  $-5.7V$ ,  $V_{CC} = V_{CCA} = GND$

Symbol	Parameter	$T_C = -40^\circ C$		$T_C = +25^\circ C$		$T_C = +85^\circ C$		Units	Conditions
		Min	Max	Min	Max	Min	Max		
$t_{PLH}$ $t_{PHL}$	Propagation Delay $D_{2a}-D_{2e}$ to O, $\bar{O}$	0.45	1.70	0.55	1.60	0.55	1.70	ns	Figures 1 and 2
$t_{PLH}$ $t_{PHL}$	Propagation Delay $D_{1a}-D_{1e}$ to O, $\bar{O}$	0.45	1.50	0.55	1.40	0.55	1.50	ns	
$t_{PLH}$ $t_{PHL}$	Propagation Delay Data to F	1.05	2.55	1.15	2.55	1.15	2.80	ns	
$t_{TLH}$ $t_{THL}$	Transition Time 20% to 80%, 80% to 20%	0.35	1.10	0.35	1.10	0.35	1.10	ns	

**Military Version**

**DC Electrical Characteristics**

$V_{EE} = -4.2V$  to  $-5.7V$ ,  $V_{CC} = V_{CCA} = GND$ ,  $T_C = -55^\circ C$  to  $+125^\circ C$

Symbol	Parameter	Min	Max	Units	$T_C$	Conditions	Notes	
$V_{OH}$	Output HIGH Voltage	-1025	-870	mV	$0^\circ C$ to $+125^\circ C$	$V_{IN} = V_{IH} (Max)$ or $V_{IL} (Min)$	Loading with $50\Omega$ to $-2.0V$	1, 2, 3
		-1085	-870	mV	$-55^\circ C$			
$V_{OL}$	Output LOW Voltage	-1830	-1620	mV	$0^\circ C$ to $+125^\circ C$			
		-1830	-1555	mV	$-55^\circ C$			
$V_{OHC}$	Output HIGH Voltage	-1035		mV	$0^\circ C$ to $+125^\circ C$	$V_{IN} = V_{IH} (Min)$ or $V_{IL} (Max)$	Loading with $50\Omega$ to $-2.0V$	1, 2, 3
		-1085		mV	$-55^\circ C$			
$V_{OLC}$	Output LOW Voltage		-1610	mV	$0^\circ C$ to $+125^\circ C$			
			-1555	mV	$-55^\circ C$			
$V_{IH}$	Input HIGH Voltage	-1165	-870	mV	$-55^\circ C$ to $+125^\circ C$	Guaranteed HIGH Signal for All Inputs	1, 2, 3, 4	
$V_{IL}$	Input LOW Voltage	-1830	-1475	mV	$-55^\circ C$ to $+125^\circ C$	Guaranteed LOW Signal for All Inputs	1, 2, 3, 4	
$I_{IL}$	Input LOW Current	0.50		$\mu A$	$-55^\circ C$ to $+125^\circ C$	$V_{EE} = -4.2V$ $V_{IN} = V_{IL} (Min)$	1, 2, 3	
$I_{IH}$	Input High Current $D_{2a}-D_{2e}$ $D_{1a}-D_{1e}$		250 350	$\mu A$	$0^\circ C$ to $+125^\circ C$	$V_{EE} = -5.7V$ $V_{IN} = V_{IH} (Max)$	1, 2, 3	
			350 500	$\mu A$	$-55^\circ C$			
$I_{EE}$	Power Supply Current	-75	-25	mA	$-55^\circ C$ to $+125^\circ C$	Inputs Open	1, 2, 3	

**Note 1:** F100K 300 Series cold temperature testing is performed by temperature soaking (to guarantee junction temperature equals  $-55^\circ C$ ), then testing immediately without allowing for the junction temperature to stabilize due to heat dissipation after power-up. This provides "cold start" specs which can be considered a worst case condition at cold temperatures.

**Note 2:** Screen tested 100% on each device at  $-55^\circ C$ ,  $+25^\circ C$ , and  $+125^\circ C$ , Subgroups 1, 2, 3, 7, and 8.

**Note 3:** Sample tested (Method 5005, Table I) on each manufactured lot at  $-55^\circ C$ ,  $+25^\circ C$ , and  $+125^\circ C$ , Subgroups A1, 2, 3, 7, and 8.

**Note 4:** Guaranteed by applying specified input condition and testing  $V_{OH}/V_{OL}$ .

**Military Version** (Continued)

**AC Electrical Characteristics**

$V_{EE} = -4.2V$  to  $-5.7V$ ,  $V_{CC} = V_{CCA} = GND$

Symbol	Parameter	$T_C = -55^\circ C$		$T_C = +25^\circ C$		$T_C = +125^\circ C$		Units	Conditions	Notes
		Min	Max	Min	Max	Min	Max			
$t_{PLH}$ $t_{PHL}$	Propagation Delay $D_{2a}-D_{2e}$ to O, $\bar{O}$	0.30	2.10	0.40	1.90	0.40	2.40	ns	Figures 1 and 2	1, 2, 3
$t_{PLH}$ $t_{PHL}$	Propagation Delay $D_{1a}-D_{1e}$ to O, $\bar{O}$	0.30	1.90	0.40	1.80	0.40	2.20	ns		
$t_{PLH}$ $t_{PHL}$	Propagation Delay Data to F	0.80	2.90	0.90	2.80	0.90	3.40	ns		
$t_{TLH}$ $t_{THL}$	Transition Time 20% to 80%, 80% to 20%	0.20	1.70	0.30	1.60	0.20	1.70	ns		4

- Note 1:** F100K 300 Series cold temperature testing is performed by temperature soaking (to guarantee junction temperature equals  $-55^\circ C$ ), then testing immediately after power-up. This provides "cold start" specs which can be considered a worst case condition at cold temperatures.
- Note 2:** Screen tested 100% on each device at  $+25^\circ C$  temperature only, Subgroup A9.
- Note 3:** Sample tested (Method 5005, Table I) on each mfg. lot at  $+25^\circ C$ , Subgroup A9, and at  $+125^\circ C$  and  $-55^\circ C$  temperatures, Subgroups A10 and A11.
- Note 4:** Not tested at  $-25^\circ C$ ,  $+125^\circ C$ , and  $-55^\circ C$  temperature (design characterization data).

**Test Circuitry**

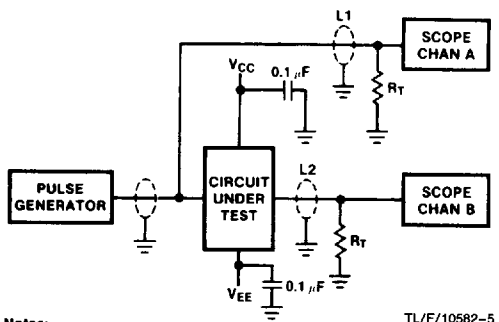

- Notes:**
- $V_{CC}, V_{CCA} = +2V$ ,  $V_{EE} = -2.5V$
  - L1 and L2 = equal length 50Ω impedance lines
  - $R_T = 50\Omega$  terminator internal to scope
  - Decoupling 0.1 μF from GND to  $V_{CC}$  and  $V_{EE}$
  - All unused outputs are loaded with 50Ω to GND
  - $C_L$  = Fixture and stray capacitance  $\leq 3$  pF

**FIGURE 1. AC Test Circuit**

**Switching Waveforms**

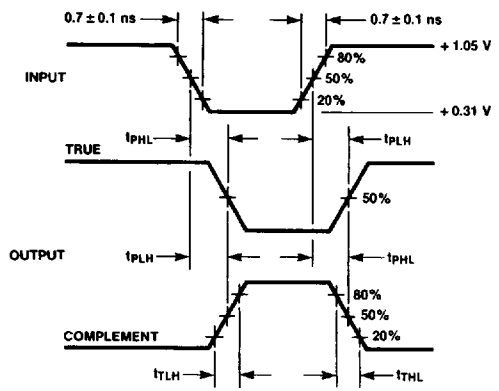

**FIGURE 2. Propagation Delay and Transition Times**