

NOT RECOMMENDED FOR NEW DESIGNS

GENERAL DESCRIPTION

The ICS8705 is a highly versatile 1:8 Differential-to-LVCMOS/ LVTTTL Clock Generator. The ICS8705 has two selectable clock inputs. The CLK1, nCLK1 pair can accept most standard differential input levels. The single ended CLK0 input accepts LVCMOS or LVTTTL input levels. The ICS8705 has a fully integrated PLL and can be configured as zero delay buffer, multiplier or divider and has an input and output frequency range of 15.625MHz to 250MHz. The reference divider, feedback divider and output divider are each programmable, thereby allowing for the following output-to-input frequency ratios: 8:1, 4:1, 2:1, 1:1, 1:2, 1:4, 1:8. The external feedback allows the device to achieve “zero delay” between the input clock and the output clocks. The PLL_SEL pin can be used to bypass the PLL for system test and debug purposes. In bypass mode, the reference clock is routed around the PLL and into the internal output dividers.

FEATURES

- 8 LVCMOS/LVTTTL outputs, 7Ω typical output impedance
- Selectable CLK1, nCLK1 or LVCMOS/LVTTTL clock inputs
- CLK1, nCLK1 pair can accept the following differential input levels: LVPECL, LVDS, LVHSTL, HCSL, SSTL
- CLK0 input accepts LVCMOS or LVTTTL input levels
- Output frequency range: 15.625MHz to 250MHz
- Input frequency range: 15.625MHz to 250MHz
- VCO range: 250MHz to 500MHz
- External feedback for “zero delay” clock regeneration with configurable frequencies
- Programmable dividers allow for the following output-to-input frequency ratios: 8:1, 4:1, 2:1, 1:1, 1:2, 1:4, 1:8
- Fully integrated PLL
- Cycle-to-cycle jitter: 45ps (maximum)
- Output skew: CLK0, 65ps (maximum)
CLK1, nCLK1, 55ps (maximum)
- Static Phase Offset: 25 ±125ps (maximum), CLK0
- Full 3.3V or 2.5V operating supply
- 0°C to 70°C ambient operating temperature
- Lead-Free package fully RoHS compliant
- **Not Recommended for New Designs.**
For new designs, contact IDT.

BLOCK DIAGRAM

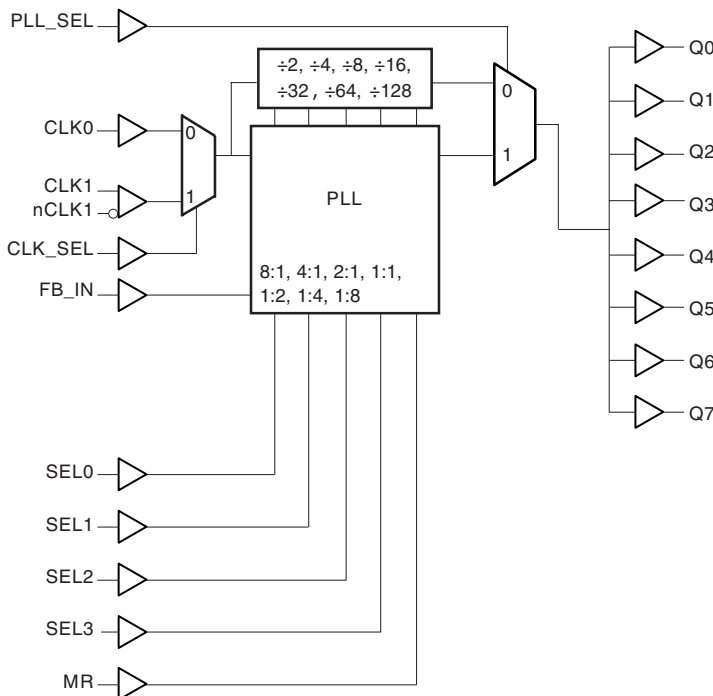

PIN ASSIGNMENT

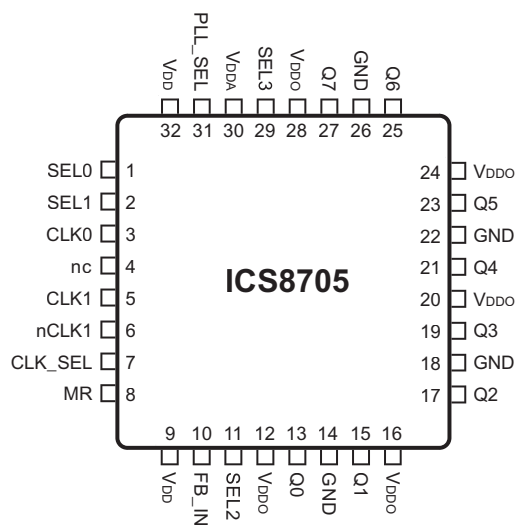

32-Lead LQFP
7mm x 7mm x 1.4 mm
Y Package
Top View

Zero Delay, Differential-to-LVCMOS/ LVTTTL Clock Generator

ICS8705
NRND

TABLE 1. PIN DESCRIPTIONS

Number	Name	Type		Description
1, 2, 11	SEL0, SEL1, SEL2	Input	Pulldown	Determines output divider values in Table 3. LVCMOS/LVTTTL interface levels.
3	CLK0	Input	Pulldown	Clock input. LVCMOS/LVTTTL interface levels.
4	nc			No connect.
5	CLK1	Input	Pulldown	Non-inverting differential clock input.
6	nCLK1	Input	Pullup	Inverting differential clock input.
7	CLK_SEL	Input	Pulldown	Clock select input. When HIGH, selects differential CLK1, nCLK1. When LOW, selects LVCMOS CLK0. LVCMOS/LVTTTL interface levels.
8	MR	Input	Pulldown	Active HIGH Master Reset. When logic HIGH, the internal dividers are reset causing the outputs to go low. When logic LOW, the internal dividers and the outputs are enabled. LVCMOS/LVTTTL interface levels.
9, 32	V _{DD}	Power		Core supply pins.
10	FB_IN	Input	Pulldown	LVCMOS/LVTTTL feedback input to phase detector for regenerating clocks with "zero delay". Connect to one of the outputs. LVCMOS/LVTTTL interface levels.
12, 16, 20, 24, 28	V _{DDO}	Power		Output supply pins.
13, 15, 17, 19, 21, 23, 25, 27	Q0, Q1, Q2, Q3, Q4, Q5, Q6, Q7	Output		Clock output. 7Ω typical output impedance. LVCMOS/LVTTTL interface levels.
14, 18, 22, 26	GND	Power		Power supply ground.
29	SEL3	Input	Pulldown	Determines output divider values in Table 3. LVCMOS/LVTTTL interface levels.
30	V _{DDA}	Power		Analog supply pin.
31	PLL_SEL	Input	Pullup	Selects between the PLL and reference clock as input to the dividers. When LOW, selects the reference clock (PLL Bypass). When HIGH, selects PLL (PLL Enabled). LVCMOS/LVTTTL interface levels.

NOTE: *Pullup* and *Pulldown* refer to internal input resistors. See Table 2, Pin Characteristics, for typical values.

TABLE 2. PIN CHARACTERISTICS

Symbol	Parameter	Test Conditions	Minimum	Typical	Maximum	Units
C _{IN}	Input Capacitance			4		pF
R _{PULLUP}	Input Pullup Resistor			51		KΩ
R _{PULLDOWN}	Input Pulldown Resistor			51		KΩ
C _{PD}	Power Dissipation Capacitance (per output)	V _{DD} , V _{DDO} , V _{DDA} = 3.465V		23		pF
R _{OUT}	Output Impedance			7		Ω

Zero Delay, Differential-to-LVCMOS/ LVTTL Clock Generator

ICS8705
NRND

TABLE 3A. PLL ENABLE FUNCTION TABLE

Inputs					Outputs PLL_SEL = 1 PLL Enable Mode
SEL3	SEL2	SEL1	SEL0	Reference Frequency Range (MHz)	Q0:Q7
0	0	0	0	125 - 250	÷ 1
0	0	0	1	62.5 - 125	÷ 1
0	0	1	0	31.25 - 62.5	÷ 1
0	0	1	1	15.625 - 31.25	÷ 1
0	1	0	0	125 - 250	÷ 2
0	1	0	1	62.5 - 125	÷ 2
0	1	1	0	31.25 - 62.5	÷ 2
0	1	1	1	125 - 250	÷ 4
1	0	0	0	62.5 - 125	÷ 4
1	0	0	1	125 - 250	÷ 8
1	0	1	0	62.5 - 125	x 2
1	0	1	1	31.25 - 62.5	x 2
1	1	0	0	15.625 - 31.25	x 2
1	1	0	1	31.25 - 62.5	x 4
1	1	1	0	15.625 - 31.25	x 4
1	1	1	1	15.625 - 31.25	x 8

TABLE 3B. PLL BYPASS FUNCTION TABLE

Inputs				Outputs PLL_SEL = 0 PLL Bypass Mode
SEL3	SEL2	SEL1	SEL0	Q0:Q7
0	0	0	0	÷ 8
0	0	0	1	÷ 8
0	0	1	0	÷ 8
0	0	1	1	÷ 16
0	1	0	0	÷ 16
0	1	0	1	÷ 16
0	1	1	0	÷ 32
0	1	1	1	÷ 32
1	0	0	0	÷ 64
1	0	0	1	÷ 128
1	0	1	0	÷ 4
1	0	1	1	÷ 4
1	1	0	0	÷ 8
1	1	0	1	÷ 2
1	1	1	0	÷ 4
1	1	1	1	÷ 2

Zero Delay, Differential-to-LVCMOS/ LVTTTL Clock Generator

ICS8705
NRND

ABSOLUTE MAXIMUM RATINGS

Supply Voltage, V_{DD}	4.6V
Inputs, V_I	-0.5V to $V_{DD} + 0.5V$
Outputs, V_O	-0.5V to $V_{DDO} + 0.5V$
Package Thermal Impedance, θ_{JA}	47.9°C/W (0 lfp/m)
Storage Temperature, T_{STG}	-65°C to 150°C

NOTE: Stresses beyond those listed under Absolute Maximum Ratings may cause permanent damage to the device. These ratings are stress specifications only. Functional operation of product at these conditions or any conditions beyond those listed in the *DC Characteristics* or *AC Characteristics* is not implied. Exposure to absolute maximum rating conditions for extended periods may affect product reliability.

TABLE 4A. POWER SUPPLY DC CHARACTERISTICS, $V_{DD} = V_{DDA} = V_{DDO} = 3.3V \pm 5\%$, $T_A = 0^\circ C$ TO $70^\circ C$

Symbol	Parameter	Test Conditions	Minimum	Typical	Maximum	Units
V_{DD}	Core Supply Voltage		3.135	3.3	3.465	V
V_{DDA}	Analog Supply Voltage		3.135	3.3	3.465	V
V_{DDO}	Output Supply Voltage		3.135	3.3	3.465	V
I_{DD}	Power Supply Current				96	mA
I_{DDA}	Analog Supply Current				15	mA
I_{DDO}	Output Supply Current				20	mA

TABLE 4B. LVCMOS / LVTTTL DC CHARACTERISTICS, $V_{DD} = V_{DDA} = V_{DDO} = 3.3V \pm 5\%$, $T_A = 0^\circ C$ TO $70^\circ C$

Symbol	Parameter	Test Conditions	Minimum	Typical	Maximum	Units
V_{IH}	Input High Voltage	PLL_SEL, CLK_SEL, SEL0, SEL1, SEL2, SEL3, FB_IN, MR	2		$V_{DD} + 0.3$	V
		CLK0	2		$V_{DD} + 0.3$	V
V_{IL}	Input Low Voltage	PLL_SEL, CLK_SEL, SEL0, SEL1, SEL2, SEL3, FB_IN, MR	-0.3		0.8	V
		CLK0	-0.3		1.3	V
I_{IH}	Input High Current	CLK0, CLK_SEL, MR, FB_IN, SEL0, SEL1, SEL2, SEL3	$V_{DD} = V_{IN} = 3.465V$		150	μA
		PLL_SEL	$V_{DD} = V_{IN} = 3.465V$		5	μA
I_{IL}	Input Low Current	CLK0, CLK_SEL, MR, FB_IN, SEL0, SEL1, SEL2, SEL3	$V_{DD} = 3.465V, V_{IN} = 0V$	-5		μA
		PLL_SEL	$V_{DD} = 3.465V, V_{IN} = 0V$	-150		μA
V_{OH}	Output High Voltage; NOTE 1		2.6			V
V_{OL}	Output Low Voltage; NOTE 1				0.5	V

NOTE 1: Outputs terminated with 50Ω to $V_{DDO}/2$. In the Parameter Measurement Information Section, see "3.3V Output Load Test Circuit".

Zero Delay, Differential-to-LVCMOS/ LVTTTL Clock Generator

ICS8705
NRND

TABLE 4C. DIFFERENTIAL DC CHARACTERISTICS, $V_{DD} = V_{DDA} = V_{DDO} = 3.3V \pm 5\%$, $T_A = 0^\circ\text{C}$ TO 70°C

Symbol	Parameter	Test Conditions	Minimum	Typical	Maximum	Units
I_{IH}	Input High Current	CLK1	$V_{DD} = V_{IN} = 3.465V$		150	μA
		nCLK1	$V_{DD} = V_{IN} = 3.465V$		5	μA
I_{IL}	Input Low Current	CLK1	$V_{DD} = 3.465V, V_{IN} = 0V$	-5		μA
		nCLK1	$V_{DD} = 3.465V, V_{IN} = 0V$	-150		μA
V_{PP}	Peak-to-Peak Input Voltage		0.15		1.3	V
V_{CMR}	Common Mode Input Voltage; NOTE 1, 2		GND + 0.5		$V_{DD} - 0.85$	V

NOTE 1: Common mode voltage is defined as V_{IH} .

NOTE 2: For single ended applications, the maximum input voltage for CLK1, nCLK1 is $V_{DD} + 0.3V$.

TABLE 5A. AC CHARACTERISTICS, $V_{DD} = V_{DDA} = V_{DDO} = 3.3V \pm 5\%$, $T_A = 0^\circ\text{C}$ TO 70°C

Symbol	Parameter	Test Conditions	Minimum	Typical	Maximum	Units	
f_{MAX}	Output Frequency		15.625		250	MHz	
t_{pLH}	Propagation Delay, Low-to-High; NOTE 1	CLK0	PLL_SEL = 0V, $f \leq 250\text{MHz}, Q_x \div 2$	5		7	ns
		CLK1, nCLK1	PLL_SEL = 0V, $f \leq 250\text{MHz}, Q_x \div 2$	5		7.3	ns
$t(\theta)$	Static Phase Offset; NOTE 2, 4	CLK0	PLL_SEL = 3.3V, $f_{REF} \leq 200\text{MHz}, Q_x \div 1$	-100	25	150	ps
		CLK1, nCLK1	PLL_SEL = 3.3V, $f_{REF} \leq 167\text{MHz}, Q_x \div 1$	-15	+135	285	ps
			PLL_SEL = 3.3V, $f_{REF} = 200\text{MHz}, Q_x \div 1$	-50	+100	250	ps
		CLK0	PLL_SEL = 3.3V, $f_{REF} = 66\text{MHz}, Q_x * 2$	-150	-25	100	ps
		CLK1, nCLK1	PLL_SEL = 3.3V, $f_{REF} = 66\text{MHz}, Q_x * 2$	0	150	300	ps
$t_{sk(o)}$	Output Skew; NOTE 3, 4	CLK0	PLL_SEL = 0V			65	ps
		CLK1, nCLK1	PLL_SEL = 0V			55	ps
$f_{jit(cc)}$	Cycle-to-Cycle Jitter; NOTE 4	$f_{OUT} > 40\text{MHz}$			45	ps	
t_L	PLL Lock Time				1	mS	
t_R / t_F	Output Rise/Fall Time		400		950	ps	
odc	Output Duty Cycle		43		57	%	
		PLL x 4 mode, $f_{in} = 45\text{MHz}$, $f_{OUT} = 180\text{MHz}$	47		53	%	

All parameters measured at f_{MAX} unless noted otherwise.

NOTE 1: Measured from the differential input crossing point to the output at $V_{DDO}/2$.

NOTE 2: Defined as the time difference between the input reference clock and the average feedback input signal when the PLL is locked and the input reference frequency is stable.

NOTE 3: Defined as skew between outputs at the same supply voltages and with equal load conditions. Measured at $V_{DDO}/2$.

NOTE 4: This parameter is defined in accordance with JEDEC Standard 65.

Zero Delay, Differential-to-LVCMOS/ LVTTTL Clock Generator

ICS8705
NRND

TABLE 4D. POWER SUPPLY DC CHARACTERISTICS, $V_{DD} = V_{DDA} = V_{DDO} = 2.5V \pm 5\%$, $T_A = 0^\circ C$ TO $70^\circ C$

Symbol	Parameter	Test Conditions	Minimum	Typical	Maximum	Units
V_{DD}	Core Supply Voltage		2.375	2.5	2.625	V
V_{DDA}	Analog Supply Voltage		2.375	2.5	2.625	V
V_{DDO}	Output Supply Voltage		2.375	2.5	2.625	V
I_{DD}	Power Supply Current				90	mA
I_{DDA}	Analog Supply Current				15	mA
I_{DDO}	Output Supply Current				20	mA

TABLE 4E. LVCMOS / LVTTTL DC CHARACTERISTICS, $V_{DD} = V_{DDA} = V_{DDO} = 2.5V \pm 5\%$, $T_A = 0^\circ C$ TO $70^\circ C$

Symbol	Parameter	Test Conditions	Minimum	Typical	Maximum	Units
V_{IH}	Input High Voltage	PLL_SEL, CLK_SEL, SEL0, SEL1, SEL2, SEL3, FB_IN, MR	2		$V_{DD} + 0.3$	V
		CLK0	2		$V_{DD} + 0.3$	V
V_{IL}	Input Low Voltage	PLL_SEL, CLK_SEL, SEL0, SEL1, SEL2, SEL3, FB_IN, MR	-0.3		0.8	V
		CLK0	-0.3		1.3	V
I_{IH}	Input High Current	CLK0, CLK_SEL, MR, FB_IN, SEL0, SEL1, SEL2, SEL3	$V_{DD} = V_{IN} = 2.625V$		150	μA
		PLL_SEL	$V_{DD} = V_{IN} = 2.625V$		5	μA
I_{IL}	Input Low Current	CLK0, CLK_SEL, MR, FB_IN, SEL0, SEL1, SEL2, SEL3	$V_{DD} = 2.625V, V_{IN} = 0V$	-5		μA
		PLL_SEL	$V_{DD} = 2.625V, V_{IN} = 0V$	-150		μA
V_{OH}	Output High Voltage; NOTE 1		1.8			V
V_{OL}	Output Low Voltage; NOTE 1				0.5	V

NOTE 1: Outputs terminated with 50Ω to $V_{DDO}/2$. In the Parameter Measurement Information section, see "2.5V Output Load Test Circuit" figure.

TABLE 4F. DIFFERENTIAL DC CHARACTERISTICS, $V_{DD} = V_{DDA} = V_{DDO} = 2.5V \pm 5\%$, $T_A = 0^\circ C$ TO $70^\circ C$

Symbol	Parameter	Test Conditions	Minimum	Typical	Maximum	Units
I_{IH}	Input High Current	CLK1	$V_{DD} = V_{IN} = 2.625V$		150	μA
		nCLK1	$V_{DD} = V_{IN} = 2.625V$		5	μA
I_{IL}	Input Low Current	CLK1	$V_{DD} = 2.625V, V_{IN} = 0V$	-5		μA
		nCLK1	$V_{DD} = 2.625V, V_{IN} = 0V$	-150		μA
V_{PP}	Peak-to-Peak Input Voltage		0.15		1.3	V
V_{CMR}	Common Mode Input Voltage; NOTE 1, 2		GND + 0.5		$V_{DD} - 0.85$	V

NOTE 1: Common mode voltage is defined as V_{IH} .

NOTE 2: For single ended applications, the maximum input voltage for CLK1, nCLK1 is $V_{DD} + 0.3V$.

Zero Delay, Differential-to-LVCMOS/ LVTTL Clock Generator

ICS8705
NRND

TABLE 5B. AC CHARACTERISTICS, $V_{DD} = V_{DDA} = V_{DDO} = 2.5V \pm 5\%$, $T_A = 0^\circ C$ TO $70^\circ C$

Symbol	Parameter	Test Conditions	Minimum	Typical	Maximum	Units	
f_{MAX}	Output Frequency		15.625		250	MHz	
t_{pLH}	Propagation Delay, Low-to-High; NOTE 1	CLK0	PLL_SEL = 0V, $f \leq 250MHz$, $Q_x \div 2$	5		7	ns
		CLK1, nCLK1	PLL_SEL = 0V, $f \leq 250MHz$, $Q_x \div 2$	5		7.3	ns
$t(\theta)$	Static Phase Offset; NOTE 2, 4	CLK0	PLL_SEL = 2.5V, $f_{REF} \leq 200MHz$, $Q_x \div 1$	-250	25	200	ps
		CLK1, nCLK1	PLL_SEL = 2.5V, $f_{REF} = 133MHz$, $Q_x \div 1$	-50	100	250	ps
			PLL_SEL = 2.5V, $f_{REF} = 200MHz$, $Q_x \div 1$	-100	+100	300	ps
		CLK1, nCLK1	PLL_SEL = 2.5V, $f_{REF} = 66MHz$, $Q_x * 2$	0	150	300	ps
$t_{sk(o)}$	Output Skew; NOTE 3, 4	CLK0	PLL_SEL = 0V			65	ps
		CLK1, nCLK1	PLL_SEL = 0V			55	ps
$f_{jit(cc)}$	Cycle-to-Cycle Jitter; NOTE 4	$f_{OUT} > 40MHz$			45	ps	
$f_{jit(\theta)}$	Phase Jitter; NOTE 4, 5	PLL_SEL = 2.5V, $f_{REF} = 66MHz$, $Q_x * 2$			± 50	ps	
t_L	PLL Lock Time				1	mS	
t_R / t_F	Output Rise/Fall Time		400		950	ps	
odc	Output Duty Cycle		43		57	%	
		PLL x 4 mode, $f_{in} = 45MHz$, $f_{OUT} = 180MHz$	45		55	%	

All parameters measured at f_{MAX} unless noted otherwise.

NOTE 1: Measured from the differential input crossing point to the output at $V_{DDO}/2$.

NOTE 2: Defined as the time difference between the input reference clock and the average feedback input signal when the PLL is locked and the input reference frequency is stable.

NOTE 3: Defined as skew between outputs at the same supply voltages and with equal load conditions. Measured at $V_{DDO}/2$.

NOTE 4: This parameter is defined in accordance with JEDEC Standard 65.

NOTE 5: Phase jitter is dependent on the input source used.

Zero Delay, Differential-to-LVCMOS/ LVTTL Clock Generator

ICS8705
NRND

PARAMETER MEASUREMENT INFORMATION

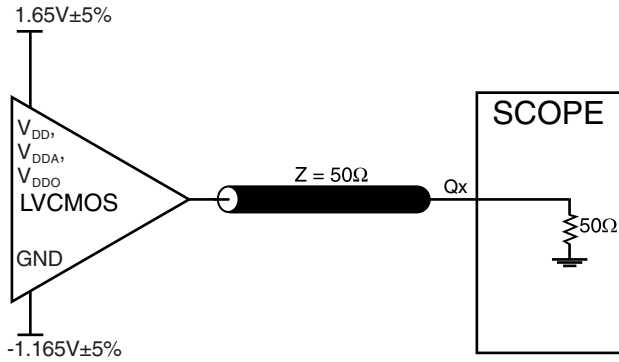

3.3V CORE/3.3V OUTPUT LOAD AC TEST CIRCUIT

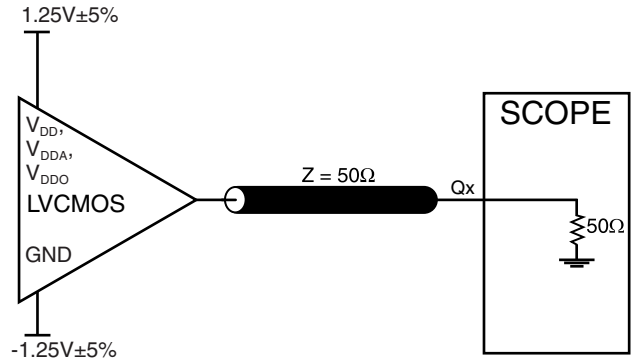

2.5V CORE/2.5V OUTPUT LOAD AC TEST CIRCUIT

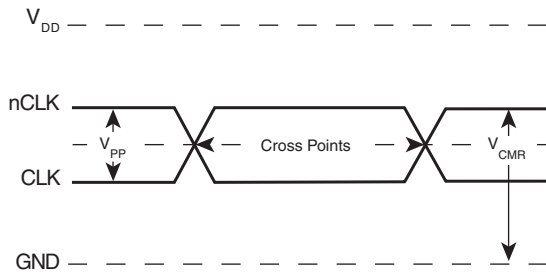

DIFFERENTIAL INPUT LEVEL

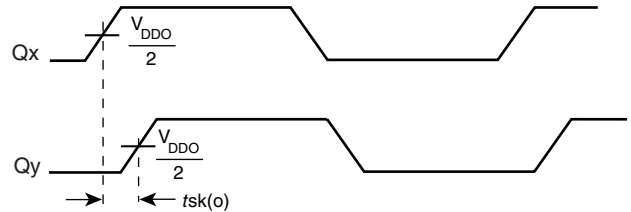

OUTPUT SKEW

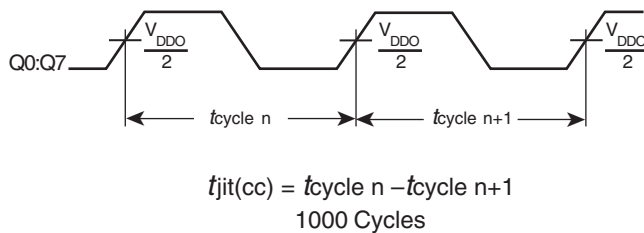

CYCLE-TO-CYCLE JITTER

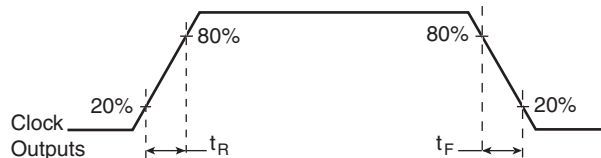

OUTPUT RISE/FALL TIME

Zero Delay, Differential-to-LVCMOS/ LVTTTL Clock Generator

ICS8705
NRND

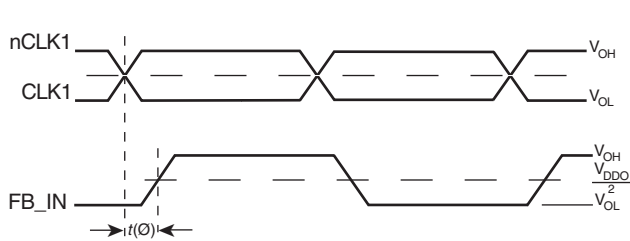

$$fjit(\varnothing) = |t(\varnothing) - t(\varnothing)_{mean}| = \text{Phase Jitter}$$

$$t(\varnothing)_{mean} = \text{Static Phase Offset}$$

(where $t(\varnothing)$ is any random sample, and $t(\varnothing)_{mean}$ is the average of the sampled cycles measured on controlled edges)

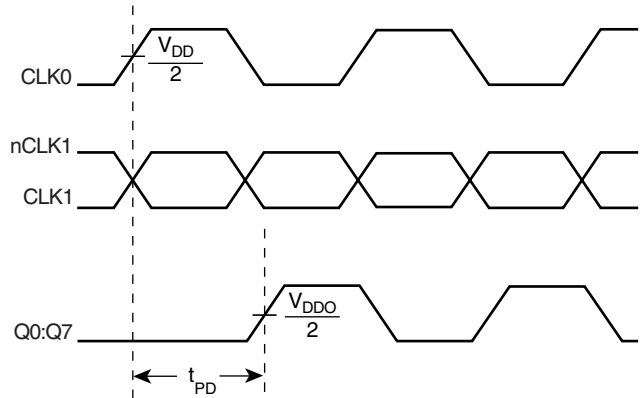

PHASE JITTER & STATIC PHASE OFFSET

PROPAGATION DELAY

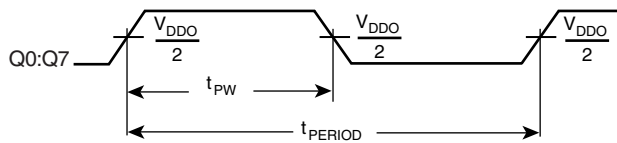

$$odc = \frac{t_{PW}}{t_{PERIOD}}$$

OUTPUT DUTY CYCLE/PULSE WIDTH/PERIOD

APPLICATION INFORMATION

POWER SUPPLY FILTERING TECHNIQUES

As in any high speed analog circuitry, the power supply pins are vulnerable to random noise. The ICS8705 provides separate power supplies to isolate any high switching noise from the outputs to the internal PLL. V_{DD} , V_{DDA} , and V_{DDO} should be individually connected to the power supply plane through vias, and bypass capacitors should be used for each pin. To achieve optimum jitter performance, power supply isolation is required. *Figure 1* illustrates how a 10Ω resistor along with a $10\mu\text{F}$ and a $.01\mu\text{F}$ bypass capacitor should be connected to each V_{DDA} .

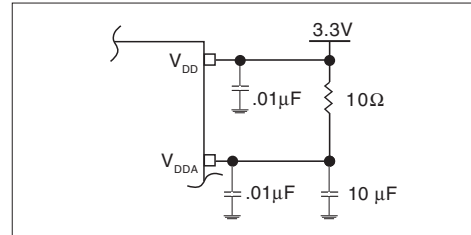

FIGURE 1. POWER SUPPLY FILTERING

WIRING THE DIFFERENTIAL INPUT TO ACCEPT SINGLE ENDED LEVELS

Figure 2 shows how the differential input can be wired to accept single ended levels. The reference voltage $V_{REF} = V_{CC}/2$ is generated by the bias resistors R1, R2 and C1. This bias circuit should be located as close as possible to the input pin. The ratio

of R1 and R2 might need to be adjusted to position the V_{REF} in the center of the input voltage swing. For example, if the input clock swing is only 2.5V and $V_{CC} = 3.3\text{V}$, V_{REF} should be 1.25V and $R2/R1 = 0.609$.

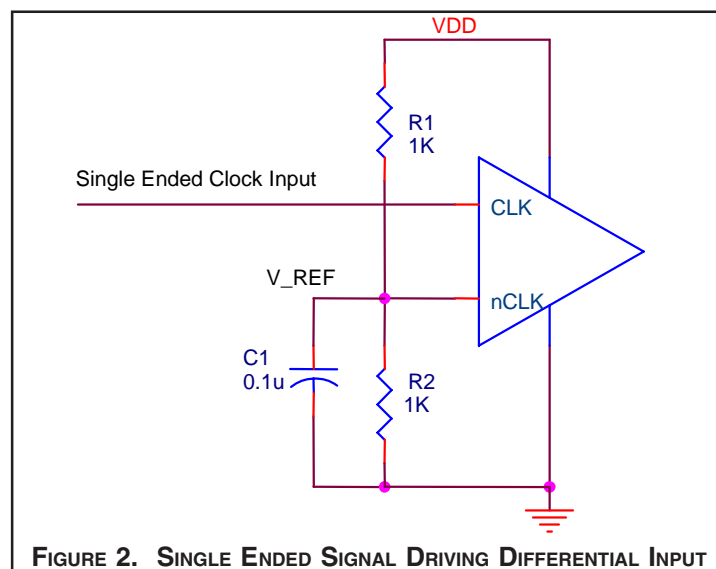

FIGURE 2. SINGLE ENDED SIGNAL DRIVING DIFFERENTIAL INPUT

DIFFERENTIAL CLOCK INPUT INTERFACE

The CLK /nCLK accepts LVDS, LVPECL, LVHSTL, SSTL, HCSL and other differential signals. Both V_{SWING} and V_{OH} must meet the V_{PP} and V_{CMR} input requirements. Figures 3A to 3D show interface examples for the CLK/nCLK input driven by the most common driver types. The input interfaces suggested here are

examples only. Please consult with the vendor of the driver component to confirm the driver termination requirements. For example in *Figure 4A*, the input termination applies for LVHSTL drivers. If you are using an LVHSTL driver from another vendor, use their termination recommendation.

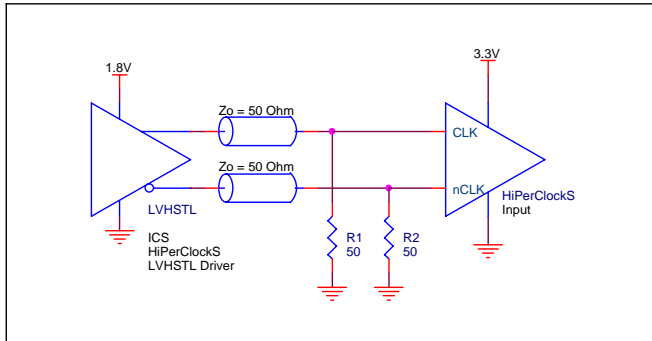

FIGURE 3A. CLK/nCLK INPUT DRIVEN BY LVHSTL DRIVER

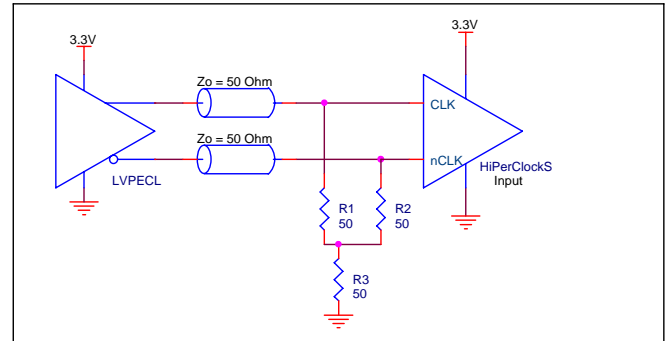

FIGURE 3B. CLK/nCLK INPUT DRIVEN BY 3.3V LVPECL DRIVER

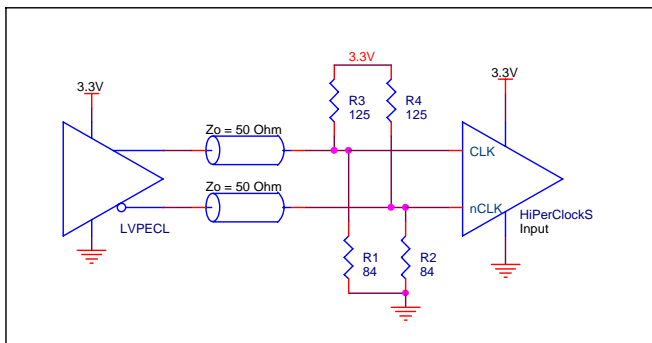

FIGURE 3C. CLK/nCLK INPUT DRIVEN BY 3.3V LVPECL DRIVER

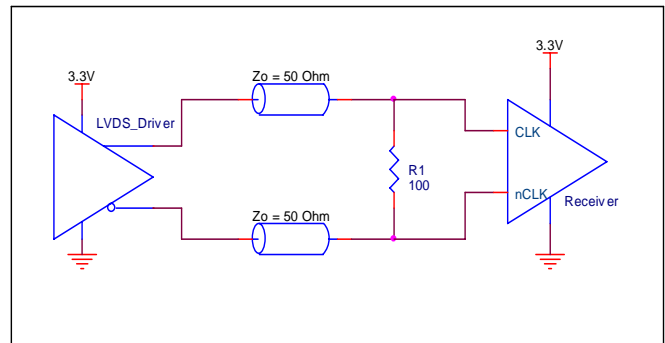

FIGURE 3D. CLK/nCLK INPUT DRIVEN BY 3.3V LVDS DRIVER

Zero Delay, Differential-to-LVCMOS/ LVTTTL Clock Generator

ICS8705
NRND

LAYOUT GUIDELINE

The schematic of the ICS8705 layout example is shown in Figure 4A. The ICS8705 recommended PCB board layout for this example is shown in Figure 4B. This layout example is used as a general guideline. The layout in the actual system will

depend on the selected component types, the density of the components, the density of the traces, and the stack up of the P.C. board.

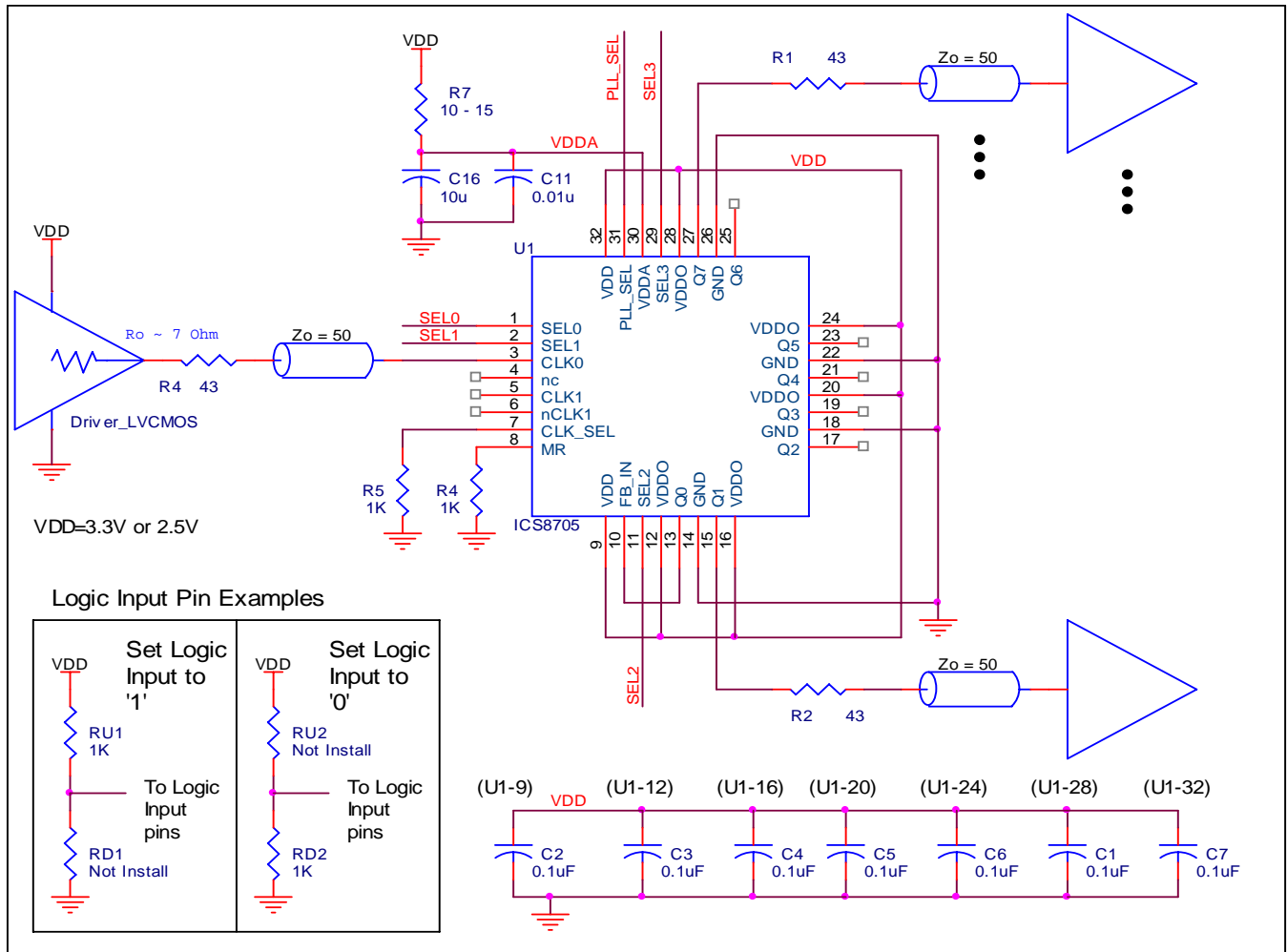

FIGURE 4A. ICS8705 LVCMOS CLOCK GENERATOR SCHEMATIC EXAMPLE

Zero Delay, Differential-to-LVCMOS/ LVTTTL Clock Generator

ICS8705
NRND

The following component footprints are used in this layout example:

All the resistors and capacitors are size 0603.

POWER AND GROUNDING

Place the decoupling capacitors as close as possible to the power pins. If space allows, placement of the decoupling capacitor on the component side is preferred. This can reduce unwanted inductance between the decoupling capacitor and the power pin caused by the via.

Maximize the power and ground pad sizes and number of vias capacitors. This can reduce the inductance between the power and ground planes and the component power and ground pins.

The RC filter consisting of R7, C11, and C16 should be placed as close to the V_{DDA} pin as possible.

CLOCK TRACES AND TERMINATION

Poor signal integrity can degrade the system performance or cause system failure. In synchronous high-speed digital systems, the clock signal is less tolerant to poor signal integrity than other signals. Any ringing on the rising or falling edge or excessive ring back can cause system failure. The shape of the trace and the

trace delay might be restricted by the available space on the board and the component location. While routing the traces, the clock signal traces should be routed first and should be locked prior to routing other signal traces.

- The differential 50Ω output traces should have same length.
- Avoid sharp angles on the clock trace. Sharp angle turns cause the characteristic impedance to change on the transmission lines.
- Keep the clock traces on the same layer. Whenever possible, avoid placing vias on the clock traces. Placement of vias on the traces can affect the trace characteristic impedance and hence degrade signal integrity.
- To prevent cross talk, avoid routing other signal traces in parallel with the clock traces. If running parallel traces is unavoidable, allow a separation of at least three trace widths between the differential clock trace and the other signal trace.
- Make sure no other signal traces are routed between the clock trace pair.
- The series termination resistors should be located as close to the driver pins as possible.

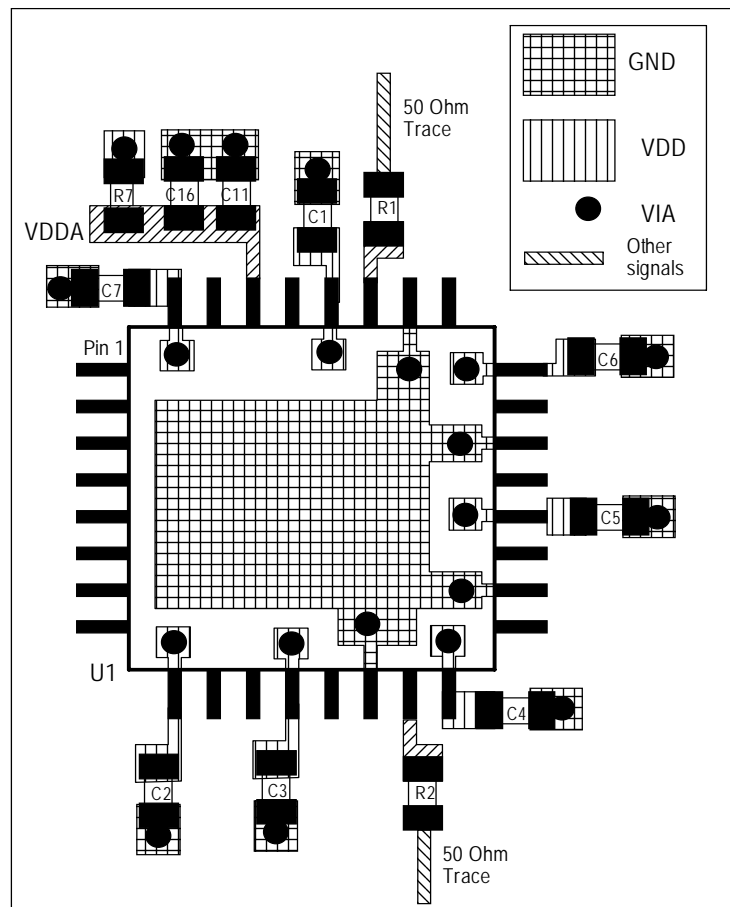

FIGURE 4B. PCB BOARD LAYOUT FOR ICS8705

RELIABILITY INFORMATION

TABLE 6. θ_{JA} VS. AIR FLOW TABLE FOR 32 LEAD LQFP

θ_{JA} by Velocity (Linear Feet per Minute)			
	0	200	500
Single-Layer PCB, JEDEC Standard Test Boards	67.8°C/W	55.9°C/W	50.1°C/W
Multi-Layer PCB, JEDEC Standard Test Boards	47.9°C/W	42.1°C/W	39.4°C/W

NOTE: Most modern PCB designs use multi-layered boards. The data in the second row pertains to most designs.

TRANSISTOR COUNT

The transistor count for ICS8705 is: 3126

Zero Delay, Differential-to-LVCMOS/ LVTTTL Clock Generator

ICS8705
NRND

PACKAGE OUTLINE - Y SUFFIX FOR 32 LEAD LQFP

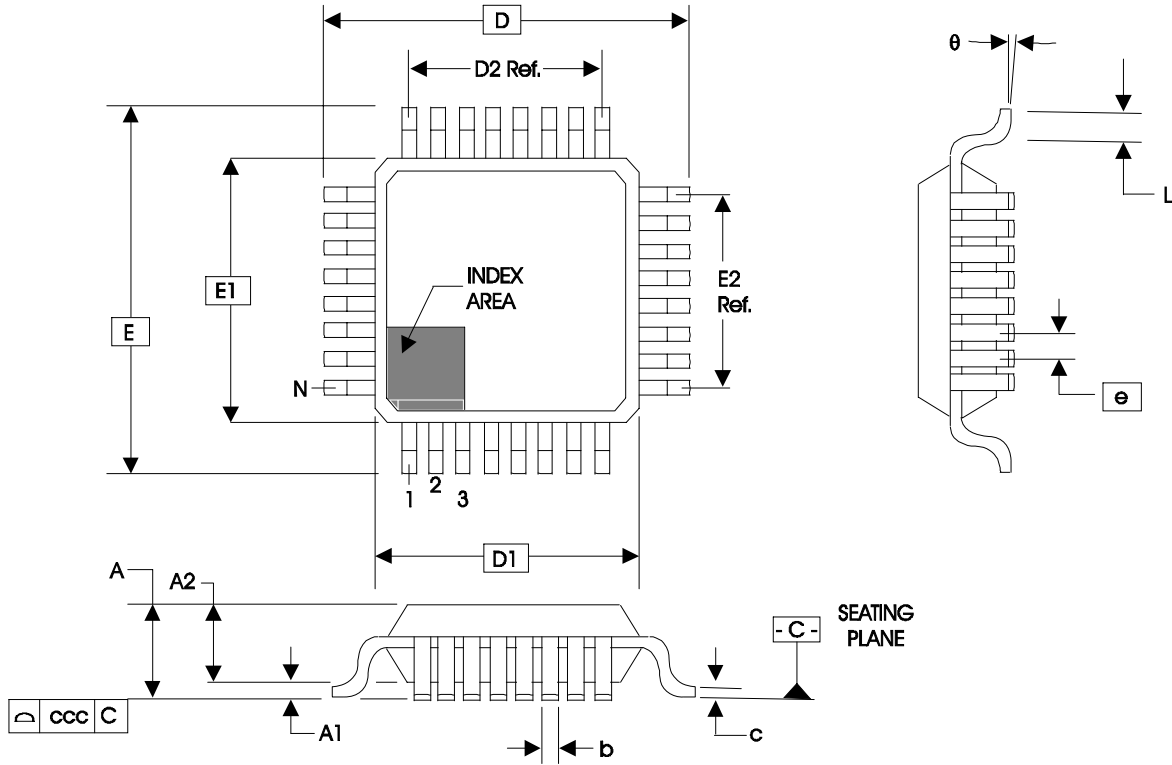

TABLE 7. PACKAGE DIMENSIONS

JEDEC VARIATION ALL DIMENSIONS IN MILLIMETERS			
SYMBOL	BBA		
	MINIMUM	NOMINAL	MAXIMUM
N	32		
A	--	--	1.60
A1	0.05	--	0.15
A2	1.35	1.40	1.45
b	0.30	0.37	0.45
c	0.09	--	0.20
D	9.00 BASIC		
D1	7.00 BASIC		
D2	5.60 Ref.		
E	9.00 BASIC		
E1	7.00 BASIC		
E2	5.60 Ref.		
e	0.80 BASIC		
L	0.45	0.60	0.75
θ	0°	--	7°
ccc	--	--	0.10

Reference Document: JEDEC Publication 95, MS-026

Zero Delay, Differential-to-LVCMOS/ LVTTL Clock Generator

ICS8705
NRND

TABLE 8. ORDERING INFORMATION

Part/Order Number	Marking	Package	Shipping Packaging	Temperature
8705BYLF	ICS8705BYLF	32 lead "Lead Free" LQFP	Tray	0°C to +70°C
8705BYLFT	ICS8705BYLF	32 lead "Lead Free" LQFP	2500 Tape and Reel	0°C to +70°C

NOTE: "LF" suffix to the part number are the PB-free configuration, RoHS compliant

Zero Delay, Differential-to-LVCMOS/ LVTTTL Clock Generator

ICS8705
NRND

REVISION HISTORY SHEET				
Rev	Table	Page	Description of Change	Date
A		1	Updated Block Diagram	1/25/02
B	T3A	3	PLL Enable Function Table - revised the Reference Frequency Range column	3/14/02
	T5A	5	3.3V AC Characteristics Table - updated the Output Frequency row from 350MHz Max. to 275MHz Max.	
	T4D:T4F; T5B	6, 7	Added 2.5V tables.	
C	T3A	3	PLL Enable Function Table - revised the Reference Frequency Range column	4/4/02
	T5A	5	3.3V AC Characteristics Table - updated the Output Frequency row from 275MHz Max. to 250MHz Max.	
	T5B	7	2.5V AC Characteristics Table - updated the Output Frequency row from 275MHz Max. to 250MHz Max.	
C	T1	2	Pin Description Table - revised power pin descriptions.	4/10/02
C	T2	2	Pin Characteristics Table - add 23pF (typical) in C _{PD} row.	7/15/02
C	T1	2	Pin Description Table - Pin# 10 from description, replaced "Connect to pin 10." with "Connect to one of the outputs."	8/1/02
C	T1	2	Revised CLK0 description and MR description.	8/21/02
		8	Revised Output Rise/Fall Time Diagram.	
D	T1, T4A, T4D T5A, T5B	2, 4, 6	Revised description for V _{DD} to read Core supply from Positive supply.	11/22/02
		5, 7	AC Characteristics, added another row to "odc" with different test conditions and values. Updated format.	
E	1	2	Pin Description table - revised MR description.	1/22/03
	T5A & T5B	5 & 7	AC tables - Changed the Static Phase Offset limits for CLK1, nCLK1.	
F	T5A & T5B	5 & 7	AC tables - added Static Phase Offset with "fREF = 66MHz, Qx * 2". 3.3V AC table - corrected typo in SPO parameter to read NOTE 4 from NOTE 7.	2/13/03
			Throughout datasheet revised title to read "...Differential-to-LVCMOS/LVTTTL..."	
G	T5B	7	2.5V AC Characteristics Table - added Phase Jitter spec, and Note 5.	3/14/03
		9	Replaced Static Phase Offset Diagram with Phase Jitter & SPO Diagram.	
G	T2	2	Pin Characteristics Table - changed C _{IN} from 4pF max. to 4pF typical.	5/15/03
		11	Added Differential Clock Input Interface section.	
G		12 & 13	Added Layout Guideline	6/6/03
G	T6	14	Ordering Information Table - added "Lead-Free" part number	6/16/04
G	T8	1	Features Section - added temperature bullet.	3/18/05
		16	Ordering Information Table - Added "Lead-Free" note.	
H	T8	16	Updated datasheet's header/footer with IDT from ICS. Removed "ICS" prefix from Part/Order Number column. Corrected packaging column.	7/2/10
		18	Added Contact Page.	
H		1	NRND - Not Recommended For New Designs	5/21/13

Zero Delay, Differential-to-LVCMOS/
LVTTL Clock Generator

ICS8705
NRND

IMPORTANT NOTICE AND DISCLAIMER

RENESAS ELECTRONICS CORPORATION AND ITS SUBSIDIARIES (“RENESAS”) PROVIDES TECHNICAL SPECIFICATIONS AND RELIABILITY DATA (INCLUDING DATASHEETS), DESIGN RESOURCES (INCLUDING REFERENCE DESIGNS), APPLICATION OR OTHER DESIGN ADVICE, WEB TOOLS, SAFETY INFORMATION, AND OTHER RESOURCES “AS IS” AND WITH ALL FAULTS, AND DISCLAIMS ALL WARRANTIES, EXPRESS OR IMPLIED, INCLUDING, WITHOUT LIMITATION, ANY IMPLIED WARRANTIES OF MERCHANTABILITY, FITNESS FOR A PARTICULAR PURPOSE, OR NON-INFRINGEMENT OF THIRD PARTY INTELLECTUAL PROPERTY RIGHTS.

These resources are intended for developers skilled in the art designing with Renesas products. You are solely responsible for (1) selecting the appropriate products for your application, (2) designing, validating, and testing your application, and (3) ensuring your application meets applicable standards, and any other safety, security, or other requirements. These resources are subject to change without notice. Renesas grants you permission to use these resources only for development of an application that uses Renesas products. Other reproduction or use of these resources is strictly prohibited. No license is granted to any other Renesas intellectual property or to any third party intellectual property. Renesas disclaims responsibility for, and you will fully indemnify Renesas and its representatives against, any claims, damages, costs, losses, or liabilities arising out of your use of these resources. Renesas' products are provided only subject to Renesas' Terms and Conditions of Sale or other applicable terms agreed to in writing. No use of any Renesas resources expands or otherwise alters any applicable warranties or warranty disclaimers for these products.

(Rev.1.0 Mar 2020)

Corporate Headquarters

TOYOSU FORESIA, 3-2-24 Toyosu,
Koto-ku, Tokyo 135-0061, Japan
www.renesas.com

Contact Information

For further information on a product, technology, the most up-to-date version of a document, or your nearest sales office, please visit:
www.renesas.com/contact/

Trademarks

Renesas and the Renesas logo are trademarks of Renesas Electronics Corporation. All trademarks and registered trademarks are the property of their respective owners.