



M.S.KENNEDY CORP.

10 AMP, 75V, 3 PHASE MOSFET BRIDGE WITH INTELLIGENT INTEGRATED GATE DRIVE

4400

4707 Dey Road Liverpool, M/Y. 13088

(315) 701-6751

FEATURES:

- 75 Volt Motor Supply Voltage
- 10 Amp Output Switch Capability, All N-Channel MOSFET Output Bridge
- 100% Duty Cycle High Side Conduction Capable
- Suitable for PWM Applications from DC to 100KHz
- Shoot-Through/Cross Conduction Protection
- Undervoltage Lockout Protection
- Programmable Dead-Time Control
- Low Active Enable for Bridge Shutdown Control
- Isolated Base Plate Design for High Voltage Isolation Plus Good Thermal Transfer

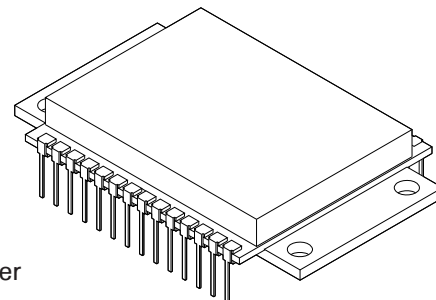

DESCRIPTION:

The MSK 4400 is a 3 phase MOSFET bridge plus drivers in a convenient isolated baseplate package. The module is capable of 10 amps of output current and 75 volts of DC bus voltage. It has a full line of protection features, including undervoltage lockout protection of the bias voltage, cross conduction control and a user programmable dead-time control for shoot-through elimination. In addition, the bridge may be shut down by using the ENABLE control. The MSK 4400 provides good thermal conductivity for the MOSFETs due to an isolated plate design that allows direct heat sinking of the device without insulators.

EQUIVALENT SCHEMATIC

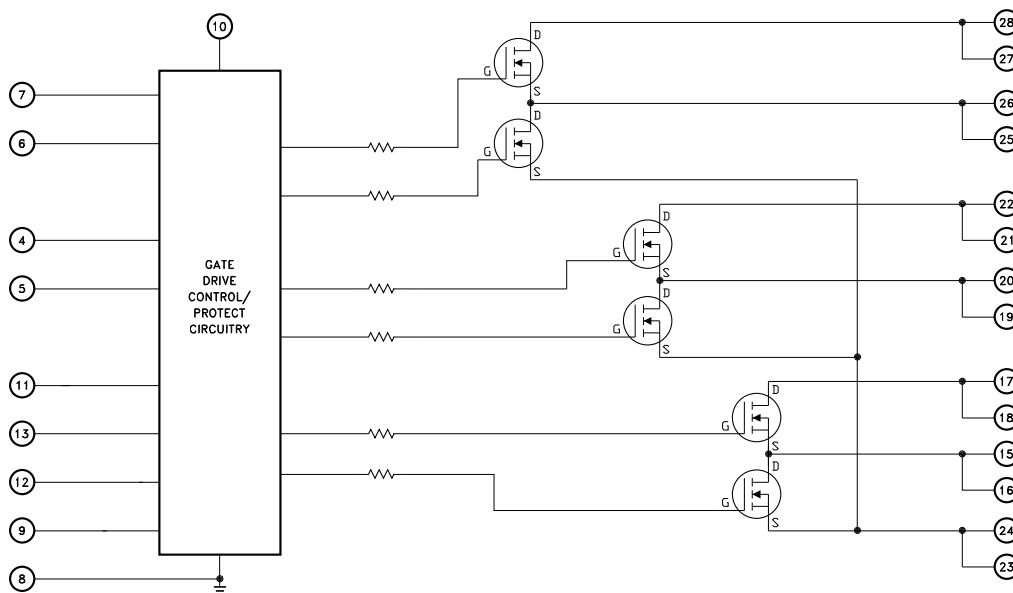

TYPICAL APPLICATIONS

- 3 Phase Brushless DC
 - Servo Control
 - Fin Actuator Control
 - Gimbal Control
- 3 Phase AC
 - Induction Motor Control
 - HVAC Blower Control

PIN-OUT INFORMATION

1	N/C	20	BØ		
2	N/C	19	BØ		
3	N/C	18	CV+	28	AV+
4	BH	17	CV+	27	AV+
5	BL	16	CØ	26	AØ
6	AL	15	CØ	25	AØ
7	AH	14	N/C	24	RSENSE
8	GND	13	CH	23	RSENSE
9	SWR	12	CL	22	BV+
10	VBIAS	11	EN	21	BV+

ABSOLUTE MAXIMUM RATINGS

⑤

V+	High Voltage Supply.	⑥	-3V transient to +75V
V _{BIAS}	Bias Supply.		-0.3V to +16V
V _{IND}	Logic Input Voltages		-0.3V to V _{BIAS} +0.3V
I _{OUT}	Continuous Output Current		10A
I _{PK}	Peak Output Current		25A
AØ, BØ, CØ.			-3V transient to +75V
R _{SENSE} .			-3V transient to +3V

θ _{JC}	Thermal Resistance		3.9 C/W
T _{ST}	Storage Temperature Range		-55°C to +150°C
T _{LD}	Lead Temperature Range (10 Seconds Lead Only).		+200°C
T _C	Case Operating Temperature		-40°C to +125°C
T _J	Junction Temperature		+150°C

ELECTRICAL SPECIFICATIONS

Parameter	Test Condition @ 25°C unless otherwise specified	MSK 4400			Units
		Min.	Typ. ③	Max.	
CONTROL SECTION					
V _{BIAS} Quiescent Current ④	All Inputs Off	-	6	7	mAmp
V _{BIAS} Operating Current ④	f = 20KHz, 50% Duty Cycle	-	22	25	mAmp
Undervoltage Threshold (Falling)		5.75	6.6	7.5	Volts
Undervoltage Threshold (Rising)		6.2	7.1	8.0	Volts
Low Level Input Voltage		-	-	0.8	Volts
High Level Input Voltage		2.7	-	-	Volts
Low Level Input Current	V _{IN} = 0V	60	100	135	µAmp
High Level Input Current	V _{IN} = 5V	-1	-	+1	µAmp
OUTPUT BRIDGE					
Drain-Source Breakdown Voltage	I _D = 100µA, All Inputs Off	75	-	-	V
Drain-Source Leakage Current	V _{DS} = 70V	-	-	50	µAmp
Drain-Source On Resistance (Each FET) ①	I _D = 25A	-	-	0.033	Ω
Voltage Drop Across Bridge Phase ② ④	I _D = 10A	-	1.3	1.5	VOLTS
SWITCHING CHARACTERISTICS					
Rise Time	V ₊ = 38V	-	62	-	nSec
Fall Time	I _D = 25A Peak	-	58	-	nSec
Enable Turn-On Prop Delay (Lower)		-	100	-	µSec
Enable Turn-Off Prop Delay (Lower)		-	100	-	µSec
Enable Turn-On Prop Delay (Upper)	\overline{SWR} Resistor = ∞	-	2	-	µSec
Enable Turn-Off Prop Delay (Upper)	\overline{SWR} Resistor = ∞	-	2	-	µSec
Dead Time	\overline{SWR} = Open	6.0	7.0	8.0	µSec
Dead Time ④	\overline{SWR} = 12K	0.3	0.5	0.7	µSec
SOURCE-DRAIN DIODE CHARACTERISTICS					
Forward Voltage	I _{SD} = 10A	-	-	1.7	Volts
Reverse Recovery Time	I _{SD} = 10A, di/dt = 100A/µS	-	120	-	nSec

NOTES:

- ① Use for maximum MOSFET junction temperature calculations.
- ② Use for overall efficiency and dissipation calculations.
- ③ Typical parameters are representative of actual device performance but are for reference only.
- ④ Parameter is 100% tested on production devices. All other parameters are guaranteed.
- ⑤ Continuous operation at or above absolute maximum ratings may adversely effect the device performance and/or life cycle.
- ⑥ When applying power to the device, apply the low voltage followed by the high voltage or alternatively, apply both at the same time. Do not apply high voltage without low voltage present.

APPLICATION NOTES

MSK 4400 PINOUT DESCRIPTIONS

A \bar{O} , B \bar{O} , C \bar{O} - Are the connections to the motor phase windings from the bridge output. The wiring to these pins should be sized according to the required current by the motor. There are no short circuit provisions for these outputs. Shorts to V+ or ground from these pins must be avoided or the bridge will be destroyed.

AL, BL, CL - Are the logic level inputs for controlling the low side switch for each of the three phases. A logic HIGH turns the low side output on, sinking the output current and pulling it down. If the corresponding high side switch is ON, the device will turn off the high side output, insert the dead time and then command the lowside output on. The low side input has priority over the high side input.

AH, BH, CH - Are the logic level inputs for controlling the high side switch for each of the three phases. A logic low turns the high side output ON, sourcing the output current and pulling it up. If the corresponding low side switch is ON, the device will ignore the high side input until the lowside is turned off and dead time has elapsed. Again, the lowside input has priority.

AV+, BV+, CV+ - Are the power connections from the hybrid to the bus. The pins for each phase are brought out separately and must be connected together to the V+ source externally. The external wiring to these pins should be sized according to the RMS current required by the motor. These pins should be bypassed by a high quality monolithic ceramic capacitor for high frequencies and enough bulk capacitance for keeping the V+ supply from drooping. 1000 μ F of bulk capacitance was used in the test circuit. The voltage range on these pins is from 16 volts up to 75 volts.

RSENSE - Is the connection point for the bottom of the three phase bridge. A low value resistor between here and the GND will produce a voltage proportional to current in the bridge. Both pins must be connected. If a resistor is not used, these pins must be connected to GND.

\overline{EN} - Is the logic level input for enabling and disabling the bridge outputs. A logic low enables output switching.

GND - Is the logic input return connection, the VBIAS return and the V+ return.

\overline{SWR} - Is the control for the amount of dead time between a high side switch ON and the corresponding low side switch OFF and vice versa. Leaving it open creates the most dead time, while connecting a 12 K resistor to VBIAS creates the least.

VBIAS - Is the supply voltage for running all of the low level logic and gate drive functions. This pin should be bypassed to GND using a 0.1 μ F ceramic capacitor and a 4.7 μ F bulk capacitor.

TYPICAL APPLICATION SCHEMATIC

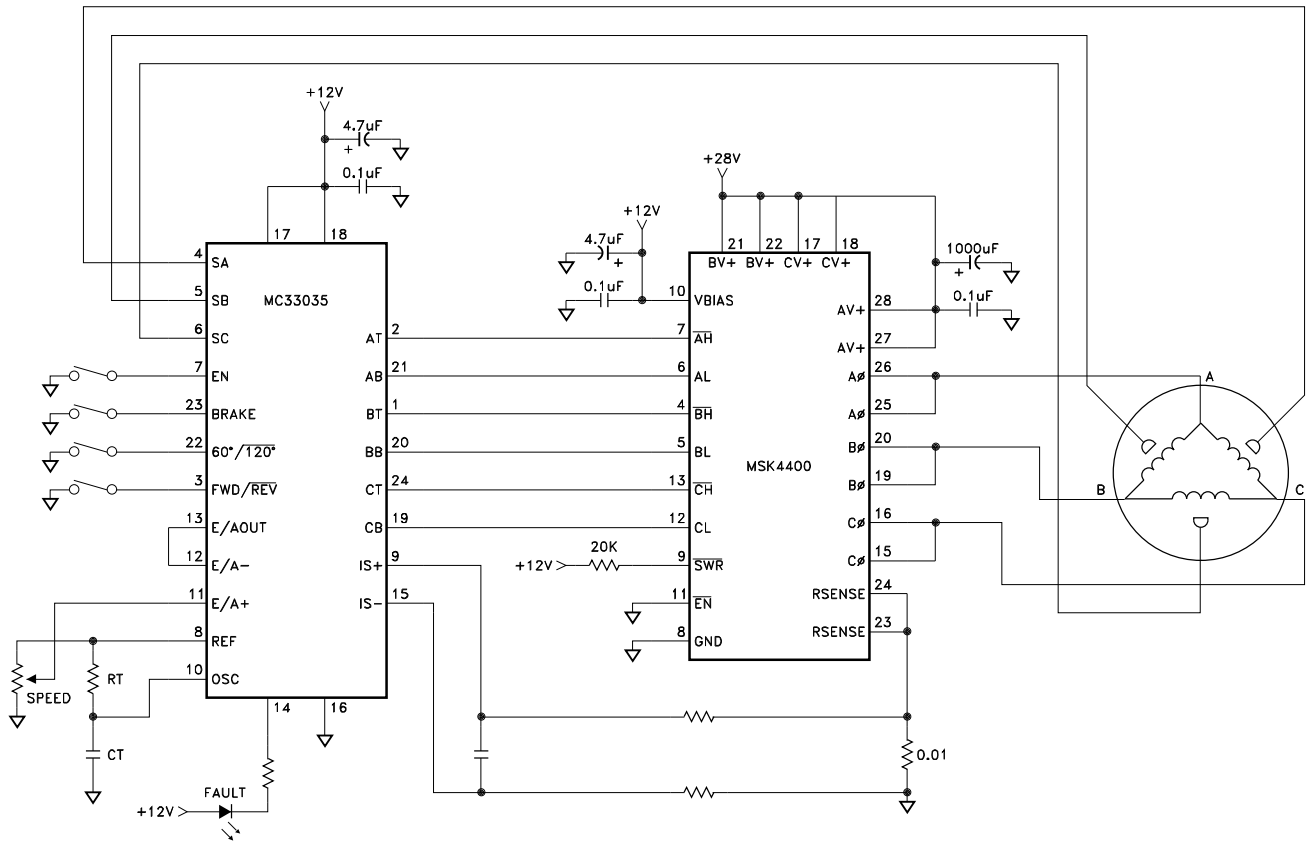

OPEN LOOP BRUSHLESS DC MOTOR SPEED CONTROL

TYPICAL PERFORMANCE CURVES

DEAD TIME vs JUNCTION TEMPERATURE

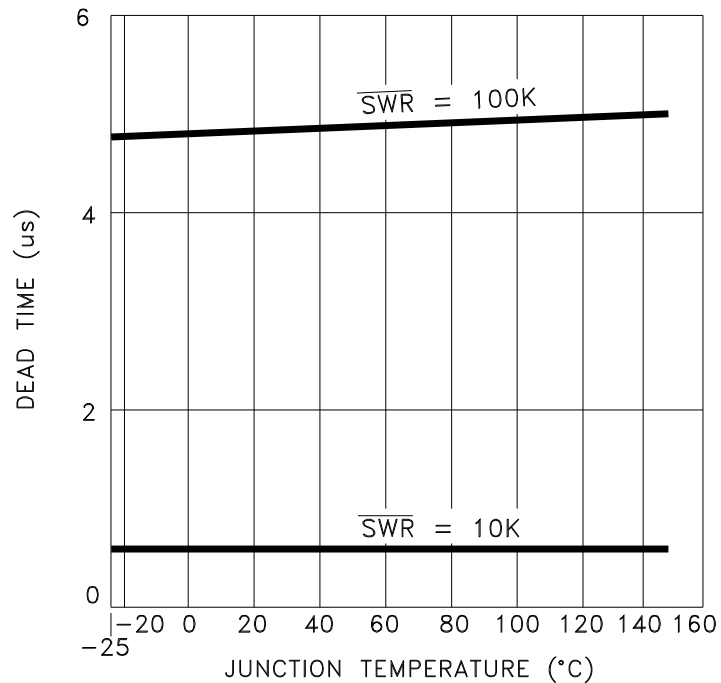

MECHANICAL SPECIFICATIONS

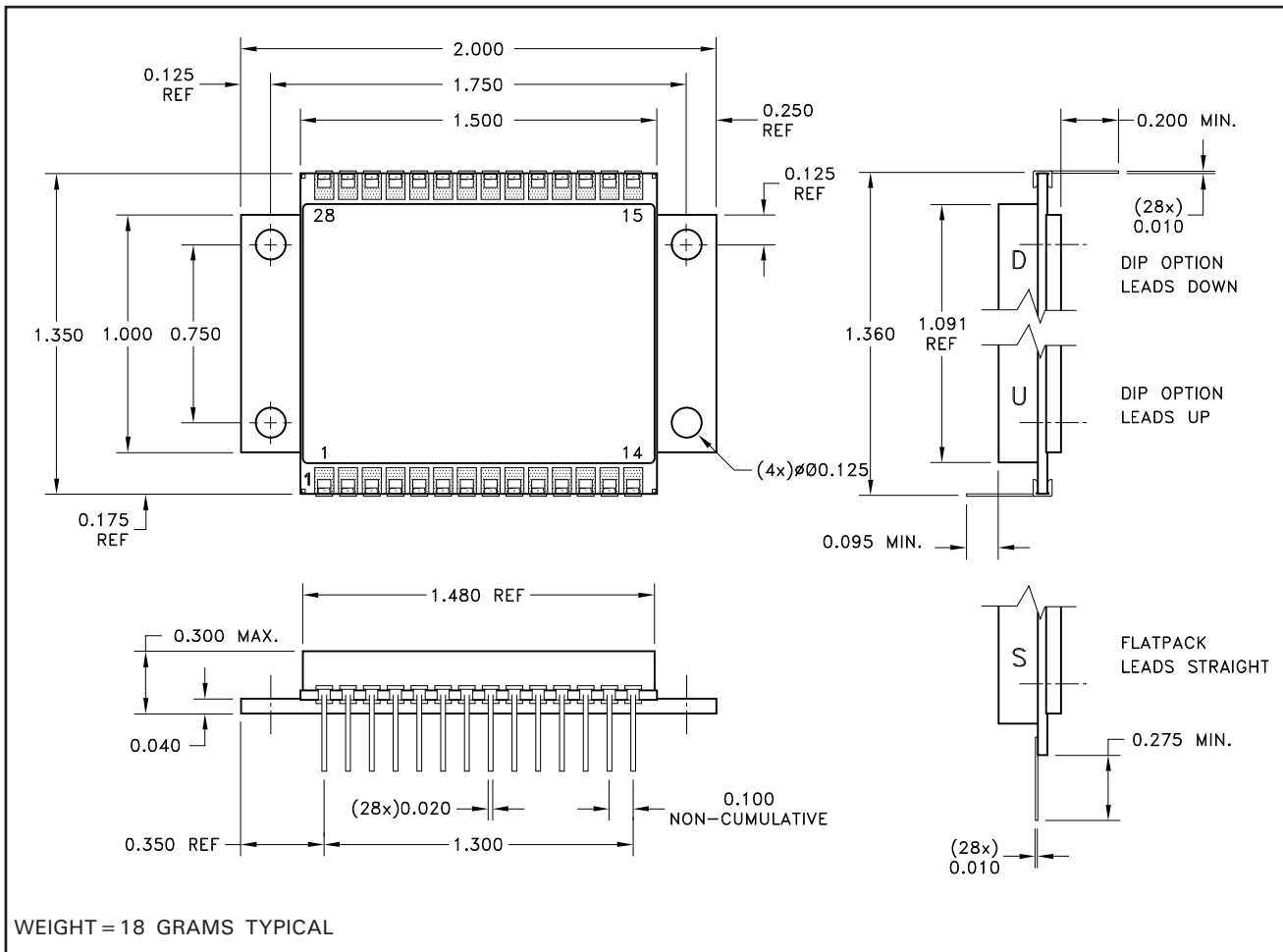

NOTE: ALL DIMENSIONS ARE ± 0.010 INCHES UNLESS OTHERWISE LABELED.

ORDERING INFORMATION

Part Number	Lead Option	Screening Level
MSK4400S	Straight	Industrial
MSK4400D	Down	Industrial
MSK4400U	Up	Industrial

M.S. Kennedy Corp.
 4707 Dey Road, Liverpool, N.Y. 13088
 Phone (315) 701-6751
 FAX (315) 701-6752
www.mskennedy.com

The information contained herein is believed to be accurate at the time of printing. MSK reserves the right to make changes to its products or specifications without notice, however, and assumes no liability for the use of its products. Please visit our website for the most recent revision of this datasheet.