

PORTABLE CONSUMER CODEC LOW-POWER, HIGH-FIDELITY INTEGRATED CODEC

TSC42XX

DESCRIPTION

The TSC42XX is a low-power, high-fidelity integrated CODEC with 24 bit stereo playback stereo record functionality. In addition to a high-fidelity low-power CODEC, the device integrates the speaker amplifier and true cap-less headphone amplifier.

The digital audio data format (I2S) works in master or slave mode and supports left/right justified, DSP and TDM modes.

Beyond high-fidelity for portable systems, the device offers an enriched “audio presence” through built-in audio output processing DSP engine (AOP). The AOP supports 12 Bands of EQ, Psychoacoustic Bass and Treble enhancement, 3D stereo enhancement and Dynamic Range controller to support Multi-band Compressor/Limiter capability.

APPLICATIONS

- Bluetooth Speakers
- Portable Navigation Devices
- Portable Gaming Devices
- Personal Media Players
- Multimedia handsets
- E-books
- Chromebook/Tablets

FEATURES

- **High fidelity CODEC**
 - 2 DAC 102dB SNR
 - 2 ADC 90dB SNR
 - 24 bit stereo DAC and 24-bit stereo ADC
 - Sample rates of 8k to 96 kHz
- **Audio Output Processing DSP Engine**
 - 3D stereo enhancement
 - 12 band parametric equalizers
 - Dynamic Range controller
 - Multi-band compressor
 - Limiter
 - Expander
 - Psychoacoustic Bass and Treble enhancement processing
 - 3rd Party algorithms
- **DDX™ Digital Speaker Driver**
 - 3W/channel 4Ω (1.5Ω8Ω)
 - TSI DDX™ class D technology achieves low EMI and high efficiency
 - >90% efficiency
 - Spread spectrum support for reduced EMI
 - Constant output power mode
 - Anti-Pop circuitry
 - Filterless architecture reduces BOM cost
- **On-chip true cap-less headphone driver**
 - 40 mW output power (16Ω)
 - Charge-pump allows true ground centered outputs
 - SNR (A-Weighted, no active signal) -122dB
 - SNR (A-Weighted, -60db active signal) -102dB
 - Headphone detection logic
- **Microphone/line-in interface**
 - Analog microphone or line-in inputs
 - Automatic level control
 - 1 stereo DMIC
- **Low power with built in power management**
 - 1.7 V CODEC supports 1Vrms
 - Very low standby and no-signal power consumption
 - 1.8V digital / 1.7V analog supply for low power
- **2-wire (I²C compatible) control interface**
- **I²S data interface**
 - Supports Bluetooth TDM mode
 - Left-Justified, Right-Justified, DSP, and TDM Audio Interfaces
- **package option**
 - 5x5 QFN
 - 7x7 QFN

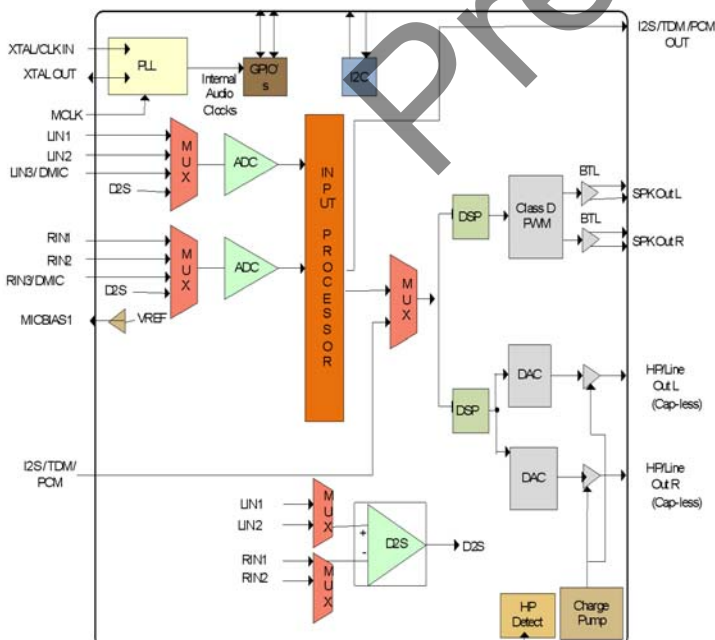

TABLE OF CONTENTS

1. OVERVIEW	8
1.1. Block Diagram	8
1.2. Audio Outputs	8
1.3. Audio Inputs	9
2. POWER MANAGEMENT	10
2.0.1. Power Management Register 1	10
2.0.2. Power Management Register 2	11
2.1. Stopping the Master Clock	11
2.1.1. Power Management1 Register	11
3. OUTPUT AUDIO PROCESSING	12
3.1. DC Removal	12
3.2. Volume Control	13
3.2.1. Volume Control Registers	14
3.3. Digital DAC Volume Control	15
3.4. Parametric Equalizer	15
3.4.1. Prescaler & Equalizer Filter	15
3.4.2. EQ Registers	17
3.4.3. EQ Filter Enables	17
3.4.4. DACCRAM STATUS Register	19
3.4.5. Equalizer, Bass, Treble Coefficient & Equalizer Prescaler RAM	19
3.5. Gain and Dynamic Range Control	23
3.6. Limiter	23
3.7. Multi-band Compressor	23
3.7.1. Overview	24
3.8. Limiter/Compressor Registers	31
3.8.1. Configuration	33
3.8.2. Controlling parameters	33
3.8.3. CLECTL Register	34
3.8.4. MUGAIN Register	34
3.8.5. COMPTHRESH Register	34
3.8.6. COMPTRATIO Register	35
3.8.7. COMPATKTC_Low Register	35
3.8.8. COMPATKTC_HI Register	35
3.8.9. COMPRELTC_Low Register	36
3.8.10. COMPRELTC_HI Register	36
3.8.11. LIMTHRESH Register	36
3.8.12. LIMTARGET Register	36
3.8.13. LIMATKTC_Low Register	37
3.8.14. LIMATKTC_High Register	37
3.8.15. LIMRELTC_Low Register	37
3.8.16. LIMRELTC_High Register	37
3.8.17. Expander Registers	38
3.8.18. Expander Ratio Register	38
3.8.19. EXPATKTC_Low Register	38
3.8.20. EXPATKTC_High Register	38
3.8.21. EXPRELTC_Low Register	38
3.8.22. EXPRELTC_High Register	39
3.9. Output Effects	39
3.9.1. FX Control Register	39
3.10. Stereo Depth (3-D) Enhancement	39
3.11. Psychoacoustic Bass Enhancement	40
3.12. Treble Enhancement	40
3.13. Mute and De-Emphasis	41
3.14. Mono Operation and Phase Inversion	41
3.14.1. DAC Control Register	41
3.15. Speaker Outputs	41
3.15.1. Headphone Output	41

3.15.1.1. Headphone Volume Control Registers	42
3.15.2. DDX™ Class D Audio Processing	42
3.15.3. Constant Output Power Mode	42
3.15.3.1. Under Voltage Lock Out	45
3.15.3.2. Registers Constant Output Power 1	46
3.15.3.3. Registers Constant Output Power 2	46
3.15.3.4. Registers Constant Output Power 3	47
3.15.3.5. Configuration Register	47
3.15.3.6. PWM Control 0 Register	48
3.15.3.7. PWM Control 1 Register	48
3.15.3.8. PWM Control 2 Register	48
3.15.3.9. PWM Control 3 Register	49
3.16. Other Output Capabilities	49
3.16.1. Audio Output Control	49
3.16.2. Speaker Enable	50
3.16.2.1. Speaker Enable Register	51
3.16.3. Speaker Operation	51
3.16.4. EQ Operation	52
3.17. Thermal Shutdown	53
3.17.1. Algorithm description:	53
3.17.2. Thermal Trip Points.	53
3.17.3. Instant Cut Mode	54
3.17.4. Short Circuit Protection	54
3.17.5. Thermal Shutdown Registers	54
3.17.5.1. Temp Sensor Control/Status Register	54
3.17.5.2. Temp Sensor Status Register	55
4. INPUT AUDIO PROCESSING	56
4.1. Analog Inputs	56
4.1.1. Input Software Control Register	57
4.2. Mono Mixing and Output Configuration	57
4.2.1. ADC D2S Input Mode Register	57
4.2.2. ADC Mono, Filter, and Inversion	58
4.2.3. ADC Data Output Configuration	58
4.3. Microphone Bias	58
4.3.1. Microphone Bias Control Register	59
4.4. Programmable Gain Control	59
4.4.1. Input PGA Software Control Register	60
4.5. ADC Digital Filter	60
4.5.1. ADC Signal Path Control Register	61
4.5.2. ADC High Pass Filter Enable Modes	61
4.6. Digital ADC Volume Control	61
4.6.1. ADC Digital Volume Control Register	62
4.7. Automatic Level Control (ALC)	62
4.7.1. ALC Operation	62
4.7.2. ALC Control Register	64
4.7.3. Peak Limiter	65
4.7.4. Input Threshold	65
4.7.5. Noise Gate Control Register	65
4.8. Digital Microphone Support	65
4.8.1. DMIC Clock	66
4.8.2. Digital Mic Control Register	68
5. DIGITAL AUDIO AND CONTROL INTERFACES	69
5.1. Data Interface	69
5.2. Master and Slave Mode Operation	69
6. AUDIO DATA FORMATS	70
6.1. PCM Interfaces	70
6.1.1. PCM(I2S) Audio Input Interface Mapping	70
6.1.2. PCM(I2S) Audio Output Interface Mapping	71
6.1.3. PCM control Register	71

6.1.4. PCM control register input	72
6.2. Left Justified Audio Interface	73
6.3. Right Justified Audio Interface (assuming n-bit word length)	73
6.4. I2S Format Audio Interface	74
6.4.1. I2S Data Interface Registers	74
6.4.2. LRCLK and BCLK Mode Control	74
6.4.3. Audio Interface Output Tri-state	75
6.4.4. Audio Interface Bit Clock and LR Clock configuration	75
6.4.5. Bit Clock and LR Clock Mode Selection	76
6.4.6. ADC Output Pin State	77
6.4.7. Audio Interface Control 3 Register	77
6.5. Bit Clock Mode	77
6.6. I2C /Control Interface	78
6.6.1. Register Write Cycle	78
6.6.2. Multiple Write Cycle	79
6.6.3. Register Read Cycle	79
6.6.4. Multiple Read Cycle	80
6.6.5. Device Addressing and Identification	80
6.6.6. Device Address Register	80
6.6.7. Device Identification Registers	80
6.6.8. Device Revision Register	81
6.6.9. Register Reset	81
6.7. GPIO's	81
6.7.1. GPIO Usage Summary	81
6.7.2. GPIO Control Registers	82
6.7.2.1. GPIO Control 1 Register	82
6.7.2.2. GPIO Control 2 Register	82
7. CLOCK GENERATION	83
7.1. On-Chip PLLs	83
7.2. System Clock Generation	84
7.2.1. PLL Dividers	84
7.2.1.1. PLLCTL0 - PLL Status Register	86
7.2.1.2. PLLCTL1B (122.88MHz) - PLL1 Control Register	87
7.2.1.3. PLLCTL9 (122.88MHz) - PLL1 Reference Clock Divider Register	87
7.2.1.4. PLLCTLA (122.88MHz) - PLL1 Output Divider Register	87
7.2.1.5. PLLCTLB (122.88MHz) - PLL1 Feedback Divider Low Register	87
7.2.1.6. PLLCTLC (122.88MHz) - PLL1 Feedback Divider High Register	87
7.2.1.7. PLLCTL12 (112.896MHz) - PLL2 Control Register	88
7.2.1.8. PLLCTLE (112.896MHz) - PLL2 Reference Clock Divider Register	88
7.2.1.9. PLLCTLF (112.896MHz) - PLL2 Output Divider Register	88
7.2.1.10. PLLCTL10 (112.896MHz) - PLL2 Feedback Divider Low Register	88
7.2.1.11. PLLCTL11 (112.896MHz) - PLL2 Feedback Divider High Register	88
7.2.1.12. PLLCTL1C - PLL Control Register	89
7.2.2. PLL Power Down Control	89
7.2.3. Audio Clock Generation	89
7.2.3.1. PLL Clock Source	89
7.2.3.2. Internal Sample Rate Control Register	89
7.2.3.3. MCLK2 Pin	91
7.2.3.4. I2S Master Mode Clock Generation	91
7.2.3.5. I2S Master Mode Sample Rate Control	91
7.2.3.6. DAC/ADC Clock Control	94
7.2.3.7. TMBASE - Timebase Register	96
8. CHARACTERISTICS	97
8.1. Electrical Specifications	97
8.1.1. Absolute Maximum Ratings	97
8.1.2. Recommended Operating Conditions	97
8.2. Device Characteristics	98
8.3. Electrical Characteristics	100
9. REGISTER MAP	101

10. PIN INFORMATION	105
10.1. TSCS42A1 Pin Diagram	105
10.2. TSCS42A2 Pin Diagram	106
10.3. TSCS42A3 Pin Diagram	107
10.4. Pin Tables	108
10.4.1. Power Pins	108
10.4.2. Reference Pins	108
10.4.3. Analog Input Pins	108
10.4.4. Analog Output Pins	109
10.4.5. Data and Control Pins	109
10.4.6. PLL Pins	109
11. PACKAGE DRAWINGS	110
11.1. 48QFN Package Outline and Package Dimensions	110
11.2. 40QFN Package Outline and Package Dimensions	111
11.3. Pb Free Process- Package Classification Reflow Temperatures	111
12. APPLICATION INFORMATION	112
13. ORDERING INFORMATION	112
14. DISCLAIMER	112
15. DOCUMENT REVISION HISTORY	113

Preliminary

LIST OF FIGURES

Output Audio Processing 12
Prescaler & EQ Filters 16
6-Tap IIR Equalizer Filter 16
DAC Coefficient RAM Write Sequence 20
DAC Coefficient RAM Read Sequence 21
Gain Compressor, Output vs Input 23
block digram Multiband compressor 24
Compressor block diagram 24
Gain Compressor, Output vs Input 32
3-D Channel Inversion 40
Constant Output Power Error 44
Constant Output Power nominal and high/low 44
Master mode 69
Slave mode 69
Left Justified Audio Interface (assuming n-bit word length) 73
Right Justified Audio Interface (assuming n-bit word length) 73
I2S Justified Audio Interface (assuming n-bit word length) 74
Bit Clock mode 78
2-Wire Serial Control Interface 79
Multiple Write Cycle 79
Read Cycle 79
Multiple Read Cycle 80
System Clock Diagram 83
Clock Generation Diagram 84
Simplified System Clock Block Diagram 86
48QFN Pin Assignment 105
48QFN Pin Assignment 106
40QFN Pin Assignment 107
48QFN Package Diagram 110
40QFN Package Diagram 111

Preliminary

LIST OF TABLES

DC_COEF_SEL Register	13
CONFIG0 Register	13
Volume Update Control Register	14
Gain Control Register	14
DAC Volume Control Register	15
DACCRAM Read Data (0x3D–LO, 0x3E–MID, 0x3F–HI), DACCRAM Write Data (0x3A–LO, 0x3B–MID, 0x3C–HI) Registers	17
DACCRAM_WRITE_LO	17
DACCRAM_WRITE_MID	17
DACCRAM_WRITE_HI	18
DACCRAM_Read_LO	18
DACCRAM_Read_MID	18
DACCRAM_Read_HI	18
DACCRAM_ADDR	19
DACCRAM_STATUS	19
DAC_Multi-band_Compressor Enable (MBCEN) Register	25
DAC_Multi-band_Compressor Control (MBCCTL) Register	26
DAC_Multi-band_Compressor Make-up Gain Band 1(MBCMUG1) Register	26
DAC_Multi-band_Compressor Threshold Band 1(MBCTHR1) Register	26
DAC_Multi-band_Compression Ratio Band 1(MBCRAT1) Register	27
DAC_Multi-band_Compressor Attack Time Constant Band 1(MBCATK1L) Register (Low)	27
DAC_Multi-band_Compressor Attack Time Constant Band 1(MBCATK1H) Register (High)	27
DAC_Multi-band_Compressor Release Time Constant Band 1(MBCREL1L) Register (Low)	27
DAC_Multi-band_Compressor Release Time Constant Band 1(MBCREL1H) Register (High)	28
DAC_Multi-band_Compressor Make-up Gain Band 2(MBCMUG2) Register	28
DAC_Multi-band_Compressor Threshold Band 2(MBCTHR2) Register	28
DAC_Multi-band_Compression Ratio Band 2(MBCRAT2) Register	28
DAC_Multi-band_Compressor Attack Time Constant Band 2(MBCATK2L) Register (Low)	29
DAC_Multi-band_Compressor Attack Time Constant Band 2(MBCATK2H) Register (High)	29
DAC_Multi-band_Compressor Release Time Constant Band 2(MBCREL2L) Register (Low)	29
DAC_Multi-band_Compressor Release Time Constant Band 2(MBCREL2H) Register (High)	29
DAC_Multi-band_Compressor Make-up Gain Band 3(MBCMUG3) Register	30
DAC_Multi-band_Compressor Threshold Band 3(MBCTHR3) Register	30
DAC_Multi-band_Compression Ratio Band 3(MBCMRAT3) Register	30
DAC_Multi-band_Compressor Attack Time Constant Band 3(MBCATK3L) Register (Low)	30
DAC_Multi-band_Compressor Attack Time Constant Band 3(MBCATK3H) Register (High)	31
DAC_Multi-band_Compressor Release Time Constant Band 3(MBCREL3L) Register (Low)	31
DAC_Multi-band_Compressor Release Time Constant Band 3(MBCRELL3H) Register (High)	31
CLECTL Register	34
MUGAIN Register	34
COMPTHRESH Register	34
COMPRATIO Register	35
COMPATKTC_Low Register	35
COMPATKTC_Hi Register	35
OMPRELTC_Low Register	36
COMPRELTC_HI Register	36
Limiter Threshold Register	36
Limiter Threshold Register	36
Limiter Attack Time Constant Register (Low)	37
Limiter Attack Time Constant Register (High)	37
Limiter Release Time Constant Register (Low)	37
Limiter Release Time Constant Register (High)	37
Expander Threshold Register	38
Expander Ratio Register	38
Expander Attack Time Constant Register (Low)	38
Expander Attack Time Constant Register (High)	38
Expander Release Time Constant Register (Low)	38
Expander Release Time Constant Register (High)	39
FXCTL	39

TSCS42XX

Portable Consumer CODECs

CNVRTR1 Register 41
HPVOL L/R Registers 42
Constant Output Power 1 Register 46
Constant Output Power 2 Register 46
Constant Output Power 3 Register 47
CONFIG0 Register 47
PWM0 Register 48
PWM1 Register 48
PWM2 Register 48
PWM3 Register 49
Power Management 2 Register 49
Additional Control Register 51
Speaker Operation 51
EQ Operation 52
THERMTS Register 54
THERMTSPKR1 Register 55
THERMTSPKR2 Register 55
PCM Control Register 71
PCM Control Register 71
PCM Control Register 72
PCM Control Register 72
AIC2 Register 75
Bit Clock and LR Clock Mode Selection 76
ADC Data Output pin state 77
AIC3 Register 77
Master Mode BCLK Frequency Control Register 77
DEVADRI Register 80
DEVID H&L Registers 80
REVID Register 81
RESET Register 81
GPIO Pin Usage Summary 81
GPIO Control Register 82
GPIO Control Register 82
Typical PLL Divider Values 85
PLL Status Register 86
PLL1 Control Register 87
PLL1 Reference Clock Divider Register 87
PPL1 Output Divider Register 87
PLL1 Feedback Divider Low Register 87
PLL1 Feedback Divider High Register 87
PLL2 Control Register 88
PLL2 Reference Clock Divider Register 88
PLL2 Output Divider Register 88
PLL2 Feedback Divider Low Register 88
PLL2 Feedback Divider High Register 88
PLL Control Register 89
Internal Sample Rate Control Register 90
Internal Sample Rate Control Register 90
I2S Master Mode Rate Control Register 92
DAC/ADC Clock Control 95
Time Base Register 96
Electrical Specification: Maximum Ratings 97
Recommended Operating Conditions 97
Device Characteristics 98
PLL Section DC Characteristics 100
Power Pins 108
Reference Pins 108
Analog Input Pins 108
Analog Output Pins 109

TSCS42XX

Portable Consumer CODECs

Data and Control Pins 109

PLL Pins 109

Reflow Temperatures 111

Preliminary

1. OVERVIEW

1.1. Block Diagram

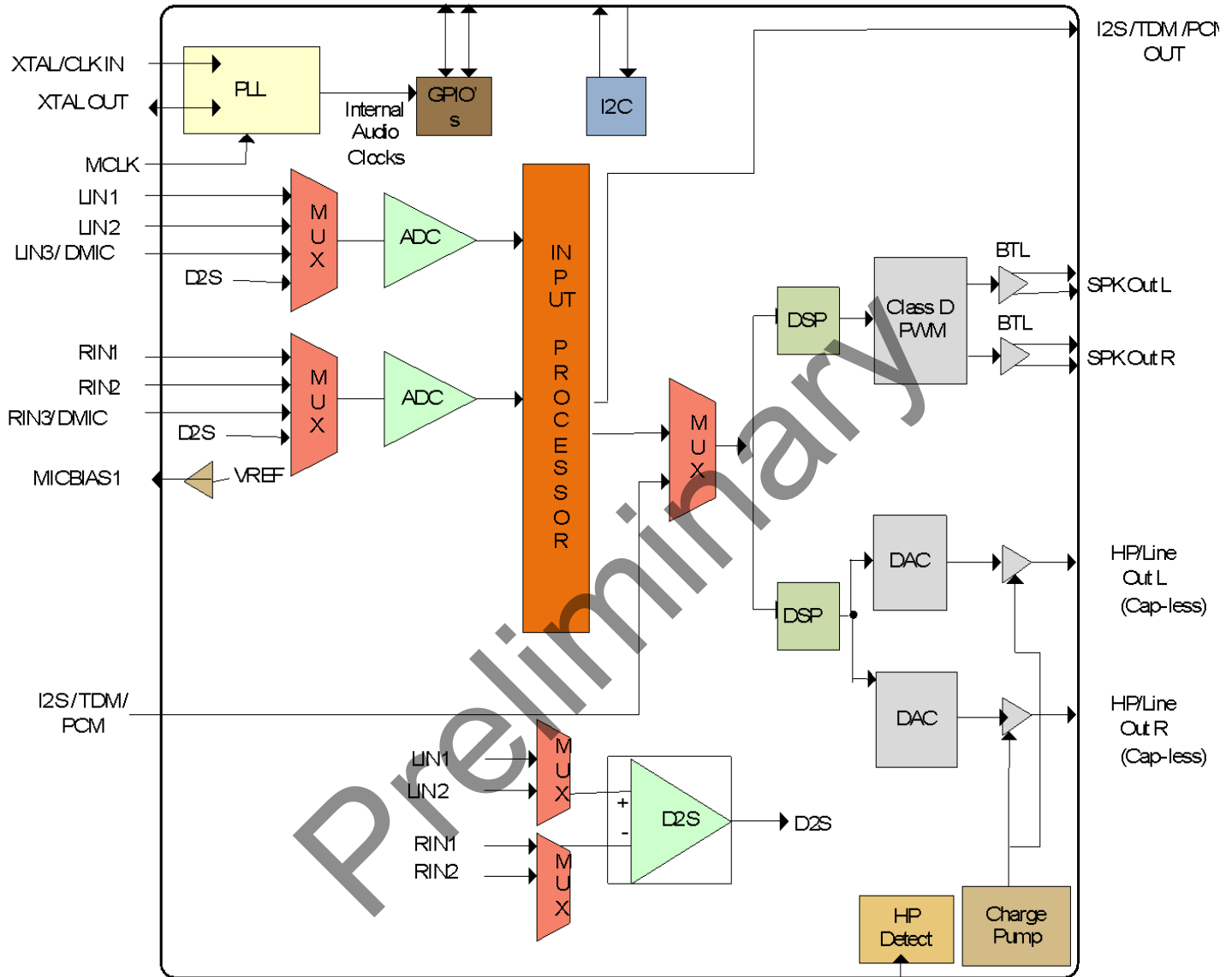

1.2. Audio Outputs

The TSC42XX provides multiple outputs for analog sound. Audio outputs include:

- A stereo 3W/channel (4Ω) or a 1.5W/channel (8Ω) filter-less DDX™ Class D amplifier. This amplifier is capable of driving the speakers typically found in portable equipment, providing high fidelity, high efficiency, and excellent sound quality.
- A line-out/cap less stereo headphone port with ground referenced outputs, capable of driving headphones without requiring an external DC blocking capacitor.
- Constant output power mode maintains output volume with dropping battery supply voltage

TSCS42XX

Portable Consumer CODECs

Each endpoint features independent volume controls, including a soft-mute capability which can slowly ramp up or down the volume changes to avoid unwanted audio artifacts.

The TSC42XX output signal paths consist of digital filters, DACs and output drivers. The digital filters and DACs are enabled when the TSC42XX is in 'playback only' or 'record and playback' mode. The output drivers can be separately enabled by individual control bits.

The digital filter and audio processing block processes the data to provide volume control and numerous sound enhancement algorithms. Two high performance sigma-delta audio DACs convert the digital data into analog. The digital audio data is converted to over sampled bit streams using 24-bit digital interpolation filters, which then enters sigma-delta DACs, and become converted to high quality analog audio signals.

To enhance the sound available from the small, low-power speakers typically found in a portable device, the TSC42XX provides numerous audio enhancement capabilities. The TSC42XX features 12 independent, programmable left/right equalization, allowing the system designer to provide an advanced system equalizer to accommodate the specific speakers and enclosure design. A multiband compressor/limiter features programmable attack and release thresholds, enabling the system designer to attenuate loud noise excursions to avoid speaker artifacts, thus allowing the underlying content to be played at a louder volume without distortion. For compressed audio, a programmable expander is available to help restore the dynamic range of the original content. A stereo depth enhancement algorithm allows common left/right content (e.g. dialog) to be attenuated separately from other content, providing a perceived depth separation between background and foreground audio. Psychoacoustic bass and treble enhancement algorithms 3D sound achieve a rich, full tone even from originally compressed content, and even with speakers generally unable to play low-frequency sounds.

1.3. Audio Inputs

The TSCS42XX provides multiple digital and analog audio inputs. Audio inputs include

- One digital audio input
 - support all I2S formats as well as direct Bluetooth PCM mode
- Three mux selectable stereo analog line/microphone inputs with selectable differential input option
- One analog input can be swapped for two digital microphone inputs

The device provides input gain control, separate volume controls, automatic leveling capability, and programmable microphone boost to smooth input recording. A programmable silence "floor" or "threshold" can be set to minimize background noise.

2. POWER MANAGEMENT

The TSCS42XX has control registers to enable system software to control which functions are active. To minimize power consumption, unused functions should be disabled. To avoid audio artifacts, it is important to enable or disable functions in the correct order.

2.0.1. Power Management Register 1

Register Address	Bit	Label	Type	Default	Description
0x1A Power Management 1	7	BSTL	RW	0	Analog in Boost Left 0 = Power down 1 = Power up
	6	BSTR	RW	0	Analog in Boost Right 0 = Power down 1 = Power up
	5	PGAL	RW	0	Analog in PGA Left 0 = Power down 1 = Power up
	4	PGAR	RW	0	Analog in PGA Right 0 = Power down 1 = Power up
	3	ADCL	RW	0	ADC Left 0 = Power down 1 = Power up
	2	ADCR	RW	0	ADC Right 0 = Power down 1 = Power up
	1	MICB	RW	0	MICBIAS 0 = Power down 1 = Power up
	0	DIGENB	RW	0	Master clock disable 0: master clock enabled 1: master clock disabled

2.0.2. Power Management Register 2

Register Address	Bit	Label	Type	Default	Description
0x1B Power Management 2	7	D2S	RW	0	Analog in D2S AMP 0 = Power down 1 = Power up
	6	HPL	RW	0	LHP Output Buffer + DAC 0 = Power down 1 = Power up
	5	HPR	RW	0	RHP Output Buffer + DAC 0 = Power down 1 = Power up
	4	SPKL	RW	0	LSPK Output Buffer 0 = Power down 1 = Power up
	3	SPKR	RW	0	RSPK Output Buffer 0 = Power down 1 = Power up
	2	RSVD	RW		Reserved (bit implemented but unused)
	1	RSVD	RW	0	Reserved (bit implemented bur unused)
	0	VREF	RW	0	VREF (necessary for all other functions) 0 = Power down 1 = Power up

2.1. Stopping the Master Clock

In order to minimize digital core power consumption, the master clock may be stopped in Standby and OFF modes by setting the DIGENB bit (R25, bit 0).

2.1.1. Power Management1 Register

Register Address	Bit	Label	Type	Default	Description
0x1A Power Management 1	0	DIGENB	RW	0	Master clock disable 0: master clock enabled 1: master clock disabled

Note: Before DIGENB can be set, the control bits ADCL, ADCR, HPL, HPR, SPKL, and SPKR must be set to zero and a waiting time of 100ms must be observed to allow port ramping/gain fading to complete. Any failure to follow this procedure may cause pops or, if less than 1mS, may prevent the DACs and ADCs from re-starting correctly.

3. OUTPUT AUDIO PROCESSING

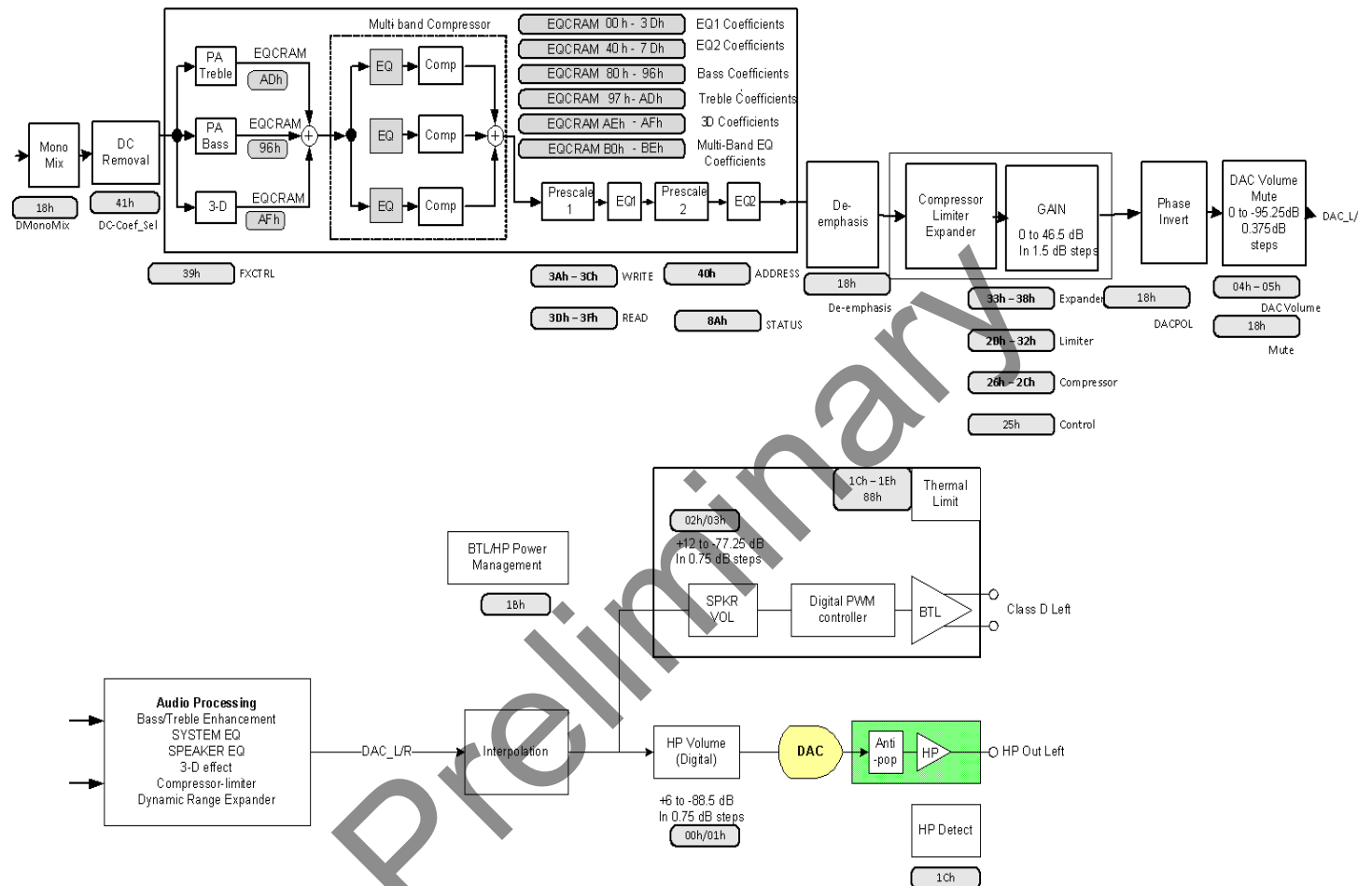

Figure 1. Output Audio Processing

3.1. DC Removal

Before processing, a DC removal filter removes the DC component from the incoming audio data. The DC removal filter is programmable.

Register Address	Bit	Label	Type	Default	Description
R65 (41h) DCOFSEL	7:3	–	R	0	Reserved for future use.
	2:0	-	RW	5	0: dc_coef = 24'h008000; //2 ⁸ -8 1: dc_coef = 24'h004000; //2 ⁹ -9 2: dc_coef = 24'h002000; //2 ¹⁰ -10 3: dc_coef = 24'h001000; //2 ¹¹ -11 4: dc_coef = 24'h000800; //2 ¹² -12 5: dc_coef = 24'h000400; //2 ¹³ -13 6: dc_coef = 24'h000200; //2 ¹⁴ -14 7: dc_coef = 24'h000100; //2 ¹⁵ -15

Table 1. DC_COEF_SEL Register

Register Address	Bit	Label	Type	Default	Description
R31 (1Fh) CONFIG0	7:6	ASDM[1:0]	RW	10h	ADC Modulator Rate
	5:4	DSDM[1:0]	RW	10h	DAC Modulator Rate
	3:2	RSVD	R	0h	Reserved for future use.
	1	dc_bypass	RW	0	1 = bypass DC removal filter
	0	sd_force_on	RW	0h	1 = supply detect forced on. 0 = supply detect on when needed (COP, UVLO enabled).

Table 2. CONFIG0 Register

3.2. Volume Control

The signal volume can be controlled digitally, across a gain and attenuation range of -95.25dB to 0dB (0.375dB steps). The level of attenuation is specified by an eight-bit code, 'DACVOL_x', where 'x' is L, or R. The value "00000000" indicates mute; other values select the number of 0.375dB steps above -95.625dB for the volume level.

The Volume Update bits control the updating of volume control data; when a bit is written as '0', the Left Volume control associated with that bit is updated when ever the left volume register is written and the Right Volume control is updated when ever the right volume register is written. When a bit is written as '1', the left volume data is placed into an internal holding register when the left volume register is written and both the left and right volumes are updated when the right volume register is written. This enables a simultaneous left and right volume update.

3.2.1. Volume Control Registers

Register Address	Bit	Label	Type	Default	Description
R10 (0Ah) VUCTL	7	ADCFade	RW	1	1 = volume fades between old/new value 0 = volume/mute changes immediately
	6	DACFade	RW	1	1 = volume fades between old/new value 0 = volume/mute changes immediately
	5	RSVD	R	0	Reserved for future use.
	4	INVOLU	RW	0	0 = Left input volume updated immediately 1 = Left input volume held until right input volume register written.
	3	ADCVOLU	RW	0	0 = Left ADC volume updated immediately 1 = Left ADC volume held until right ADC volume register written.
	2	DACVOLU	RW	0	0 = Left DAC volume updated immediately 1 = Left DAC volume held until right DAC volume register written.
	1	SPKVOLU	RW	0	0 = Left speaker volume updated immediately 1 = Left speaker volume held until right speaker volume register written.
	0	HPVOLU	RW	0	0 = Left headphone volume updated immediately 1 = Left headphone volume held until right headphone volume register written.

Table 3. Volume Update Control Register

The output path may be muted automatically when a long string of zero data is received. The length of zeros is programmable and a detection flag indicates when a stream of zero data has been detected.

Table 4. Gain Control Register

Register Address	Bit	Label	Type	Default	Description
R33 (21h) Gain Control (GAINCTL)	7	zerodet_flag	R	0	1 = zero detect length exceeded.
	6	RSVD	R	0	Reserved for future use.
	5:4	zerodetlen	RW	2	Enable mute if input consecutive zeros exceeds this length. 0 = 512, 1 = 1k, 2 = 2k, 3 = 4k samples
	3	auto_pwr	R	0	power down when mute detected
	2	auto_mute	RW	1	1 = auto mute if detect long string of zeros on input
	1	RSVD	R	0	Reserved for future use.
	0	RSVD	R	0	Reserved for future use.

3.3. Digital DAC Volume Control

The signal volume can be controlled digitally, across a gain and attenuation range of -95.25dB to 0dB (0.375dB steps). The level of attenuation is specified by an eight-bit code, 'DACVOL_x', where 'x' is L, or R. The value "00000000" indicates mute; other values select the number of 0.375dB steps above -95.625dB for the volume level.

Table 5. DAC Volume Control Register

Register Address	Bit	Label	Type	Default	Description
R4 (04h) Left DAC Volume Control	7:0	DACVOL_L [7:0]	RW	FF (0dB)	Left DAC Volume Level 0000 0000 = Digital Mute 0000 0001 = -95.25dB 0000 0010 = -94.875dB ... 0.375dB steps up to 1111 1111 = 0dB Note: If DACVOLUME is set, this setting will take effect after the next write to the Right Input Volume register.
R5 (05h) Right DAC Volume Control	7:0	DACVOL_R [7:0]	RW	FF (0dB)	Right DAC Digital Volume Level 0000 0000 = Digital Mute 0000 0001 = -95.25dB 0000 0010 = -94.875dB ... 0.375dB steps up to 1111 1111 = 0dB

3.4. Parametric Equalizer

The TSCS42XX has a 12-band digital parametric equalizer to enable fine tuning of the audio response and preferences for a given system. Each EQ may be enabled or disabled independently. Typically one EQ will be used for speaker compensation and disabled when only headphones are in use while the other EQ is used to alter the audio to make it more pleasing to the listener. This function operates on the digital audio data before it is converted back to analog by the audio DACs.

3.4.1. Prescaler & Equalizer Filter

The Equalizer Filter consists of a Prescaler and 6 cascaded 6-tap IIR Filters. The Prescaler allows the input to be attenuated prior to the EQ filters in case the EQ filters introduce gain, and would thus clip if not prescaled.

IDT provides a tool to enable an audio designer to determine appropriate coefficients for the equalizer filters. The filters enable the implementation of a 6-band parametric equalizer with selectable frequency bands, gain, and filter characteristics (high, low, or bandpass)

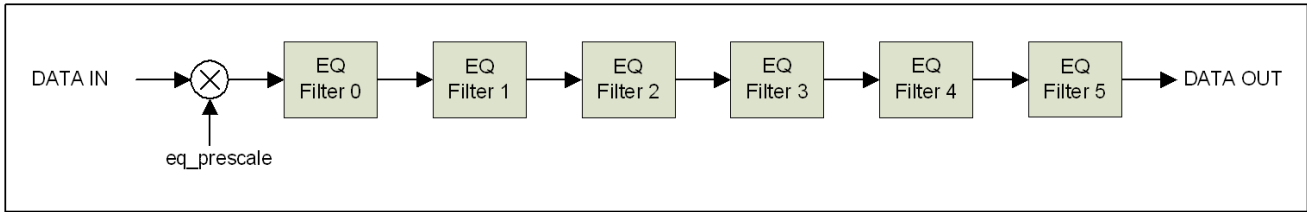

Figure 2. Prescaler & EQ Filters

The figure below shows the structure of a single EQ filter. The $a(0)$ tap is always normalized to be equal to 1 (400000h). The remaining 5 taps are 24-bit two's complement format programmable coefficients. ($-2 \leq \text{coefficient} < +2$)

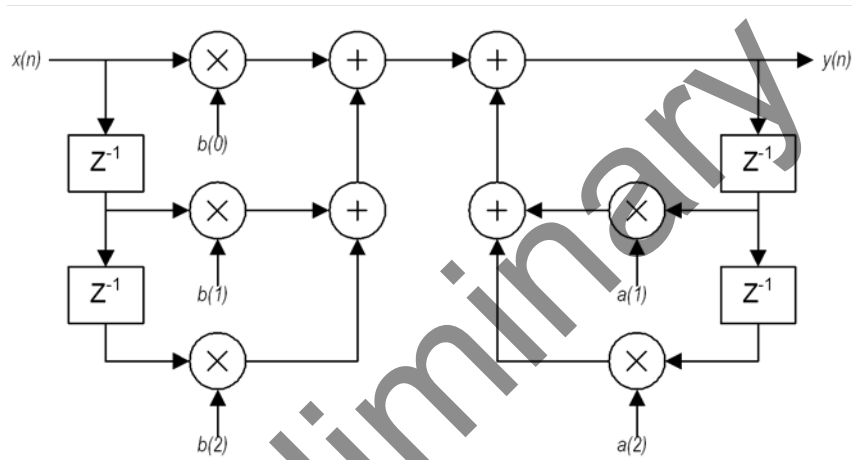

Figure 3. 6-Tap IIR Equalizer Filter

3.4.2. EQ Registers

3.4.3. EQ Filter Enables

Register Address	Bit	Label	Type	Default	Description
R32 (20h) CONFIG1	7	EQ2_EN	R/W	0	EQ bank 2 enable 0 = second EQ bypassed 1 = second EQ enabled
	6:4	EQ2_BE[2:0]	R/W	0	EQ2 band enable. When the EQ is enabled the following EQ stages are executed. 0 - Prescale only 1 - Prescale and Filter Band 0 ... 6 - Prescale and Filter Bands 0 to 5 7 - RESERVED
	3	EQ1_EN	R/W	0	EQ bank 1 enable 0 = first EQ bypassed 1 = first EQ enabled
	2:0	EQ1_BE[2:0]	R/W	0	EQ1 band enable. When the EQ is enabled the following EQ stages are executed. 0 - Prescale only 1 - Prescale and Filter Band 0 ... 6 - Prescale and Filter Bands 0 to 5 7 - RESERVED

Table 6. DACCRAM Read Data (0x3D–LO, 0x3E–MID, 0x3F–HI), DACCRAM Write Data (0x3A–LO, 0x3B–MID, 0x3C–HI) Registers

These two 24-bit registers provide the 24-bit data holding registers used when doing indirect writes/reads to the DAC Coefficient RAM.

Table 7. DACCRAM_WRITE_LO

Register Address	Bit	Label	Type	Default	Description
R58 (3Ah) DACCRAM_WRITE_LO	7:0	DACCRWD[7:0]	R/W	0	Low byte of a 24-bit data register, contains the values to be written to the DACCRAM. The address written will have be specified by the DACCRAM Address fields.

Table 8. DACCRAM_WRITE_MID

Register Address	Bit	Label	Type	Default	Description
R59 (3Bh) DACCRAM_WRITE_MID	7:0	DACCRWD[15:8]	R/W	0	Middle byte of a 24-bit data register, contains the values to be written to the DACCRAM. The address written will have be specified by the DACCRAM Address fields.

Table 9. DACCRAM_WRITE_HI

Register Address	Bit	Label	Type	Default	Description
R60 (3Ch) DACCRAM_WRITE_HI	7:0	DACCRWD[23:16]	R/W	0	High byte of a 24-bit data register, contains the values to be written to the DACCRAM. The address written will have be specified by the DACCRAM Address fields.

Table 10. DACCRAM_Read_LO

Register Address	Bit	Label	Type	Default	Description
R61 (3Dh) DACCRAM_READ_LO	7:0	DACCRRD[7:0]	R	0	Low byte of a 24-bit data register, contains the contents of the most recent DACCRAM address read from the RAM. The address read will have been specified by the DACCRAM Address fields.

Table 11. DACCRAM_Read_MID

Register Address	Bit	Label	Type	Default	Description
R62 (3Eh) DACCRAM_READ_MID	7:0	DACCRRD[15:8]	R	0	Middle byte of a 24-bit data register, contains the contents of the most recent DACCRAM address read from the RAM. The address read will have been specified by the DACCRAM Address fields.

Table 12. DACCRAM_Read_HI

Register Address	Bit	Label	Type	Default	Description
R63 (3Fh) DACCRAM_READ_HI	7:0	DACCRRD[23:16]	R	0	High byte of a 24-bit data register, contains the contents of the most recent DACCRAM address read from the RAM. The address read will have been specified by the DACCRAM Address fields.

DACCRAM Address Register

This 7-bit register provides the address to the internal RAM when doing indirect writes/reads to the DAC Coefficient RAM.

Table 13. DACCRAM_ADDR

Register Address	Bit	Label	Type	Default	Description
R64 (40h) DACCRADDR	7:0	DACCRADD	R/W	0	Contains the address (between 0 and 255) of the DACCRAM to be accessed by a read or write. This is not a byte address--it is the address of the 24-bit data item to be accessed from the DACCRAM. This address is automatically incremented after writing to DACCRAM_WRITE_HI or reading from DACCRAM_READ_HI (and the 24 bit data from the next RAM location is fetched.)

3.4.4. DACCRAM STATUS Register

This control register provides the write/read enable when doing indirect writes/reads to the DAC Coefficient RAM.

Table 14. DACCRAM_STATUS

Register Address	Bit	Label	Type	Default	Description
R138 (8Ah) DACCRSTAT	7	DACCRAM_Busy	R	0	1 = read/write to DACCRAM in progress, cleared by HW when done.
	6:0	RSVD	R	0	Reserved

3.4.5. Equalizer, Bass, Treble Coefficient & Equalizer Prescaler RAM

The DAC Coefficient RAM is a single port 176x24 synchronous RAM. It is programmed indirectly through the Control Bus in the following manner as shown in the figure below:

- 1 Write target address to DACCRAM_ADDR register. (EQ data is pre-fetched even if we don't use it)
 - a Start command followed by the Device Address and Write flag
 - b Register Address (DACCRAM_ADDR register address)
 - c Register Data (DACCRAM address to be held in DACCRAM_ADDR)
- 2 Start a multiple write cycle
 - a Start command followed by the Device Address and Write Flag
 - b Register Address of the DACCRAM_WRITE_LO register
 - c Write D7:0 to the DACCRAM_WRITE_LO register
 - d Write D15:8 to the DACCRAM_WRITE_MID register
 - e Write D23:16 to the DACCRAM_WRITE_HI register
- 3 On successful receipt of the DACCRAM_WRITE_HI data, the part will automatically start a write cycle. The DACCRAM_Busy bit will be set high to indicate that a write is in progress.
- 4 On completion of the internal write cycle, the DACCRAM_Busy bit will be 0 (when operating the control interface at high speeds - TBD - software must poll this bit to ensure the write cycle is complete before starting another write cycle.)
- 5 The bus cycle may be terminated by the host or steps 2-6 may be repeated for writes to consecutive EQ RAM locations.

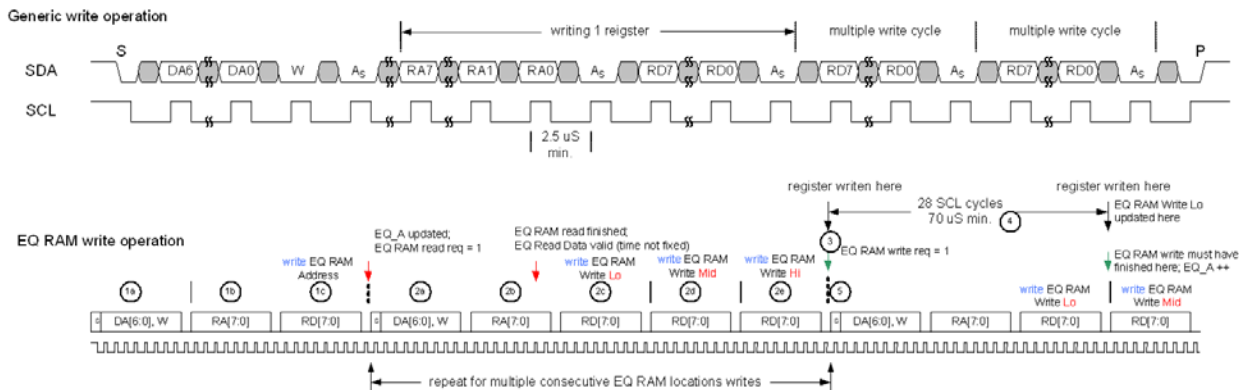

Figure 4. DAC Coefficient RAM Write Sequence

Reading back a value from the DACCRAM is done in this manner:

- 1 Write target address to DACCRAM_ADDR register.(EQ data is pre-fetched for read even if we don't use it)
 - a Start command followed by the Device Address and Write flag
 - b Register Address (DACCRAM_ADDR register address)
 - c Register Data (DACCRAM address to be held in DACCRAM_ADDR)
- 2 Start (or repeat start) a write cycle to DACCRAM_READ_LO and after the second byte (register address) is acknowledged, go to step 3. (Do not complete the write cycle.)
 - a Start command followed by the Device Address and Write Flag
 - b Register Address of the DACCRAM_READ_LO register
- 3 Signal a repeat start, provide the device address, and indicate a read operation
- 4 Read D7:0 (register address incremented after ack by host)
- 5 Read D15:8 (register address incremented after ack by host)
- 6 Read D23:16 (register address incremented and next EQ location pre-fetched after ack by host)
- 7 The host stops the bus cycle

To repeat a read cycle for consecutive EQ RAM locations:

- 8 Start (or repeat start instead of stopping the bus cycle in step 7) a write cycle indicating DACCRAM_RD_LO as the target address.
- 9 After the second byte is acknowledged, signal a repeated start.
- 10 Indicate a read operation
- 11 Read the DACCRAM_READ_LO register as described in step 4
- 12 Read the DACCRAM_READ_MID register as described in step 5
- 13 Read the DACCRAM_READ_HI register as described in step 6
- 14 Repeat steps 8-13 as desired

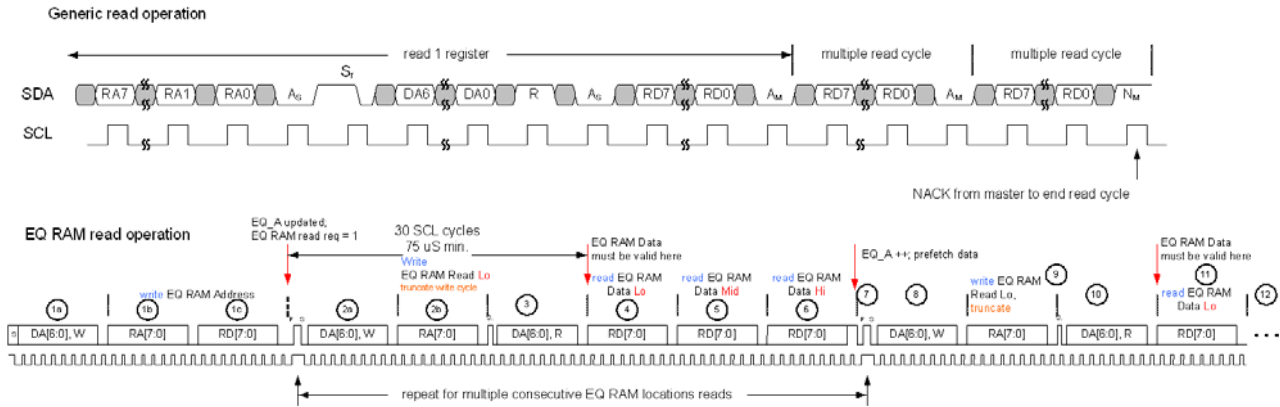

Figure 5. DAC Coefficient RAM Read Sequence

Preliminary

Table 15: DACCRAM EQ Addresses

EQ 0				EQ1			
Addr	Channel 0 Coefficients	Addr	Channel 1 Coefficients	Addr	Channel 0 Coefficients	Addr	Channel 1 Coefficients
0x00	EQ_COEF_0F0_B0	0x20	EQ_COEF_1F0_B0	0x40	EQ_COEF_2F0_B0	0x60	EQ_COEF_3F0_B0
0x01	EQ_COEF_0F0_B1	0x21	EQ_COEF_1F0_B1	0x41	EQ_COEF_2F0_B1	0x61	EQ_COEF_3F0_B1
0x02	EQ_COEF_0F0_B2	0x22	EQ_COEF_1F0_B2	0x42	EQ_COEF_2F0_B2	0x62	EQ_COEF_3F0_B2
0x03	EQ_COEF_0F0_A1	0x23	EQ_COEF_1F0_A1	0x43	EQ_COEF_2F0_A1	0x63	EQ_COEF_3F0_A1
0x04	EQ_COEF_0F0_A2	0x24	EQ_COEF_1F0_A2	0x44	EQ_COEF_2F0_A2	0x64	EQ_COEF_3F0_A2
0x05	EQ_COEF_0F1_B0	0x25	EQ_COEF_1F1_B0	0x45	EQ_COEF_2F1_B0	0x65	EQ_COEF_3F1_B0
0x06	EQ_COEF_0F1_B1	0x26	EQ_COEF_1F1_B1	0x46	EQ_COEF_2F1_B1	0x66	EQ_COEF_3F1_B1
0x07	EQ_COEF_0F1_B2	0x27	EQ_COEF_1F1_B2	0x47	EQ_COEF_2F1_B2	0x67	EQ_COEF_3F1_B2
0x08	EQ_COEF_0F1_A1	0x28	EQ_COEF_1F1_A1	0x48	EQ_COEF_2F1_A1	0x68	EQ_COEF_3F1_A1
0x09	EQ_COEF_0F1_A2	0x29	EQ_COEF_1F1_A2	0x49	EQ_COEF_2F1_A2	0x69	EQ_COEF_3F1_A2
0x0A	EQ_COEF_0F2_B0	0x2A	EQ_COEF_1F2_B0	0x4A	EQ_COEF_2F2_B0	0x6A	EQ_COEF_3F2_B0
0x0B	EQ_COEF_0F2_B1	0x2B	EQ_COEF_1F2_B1	0x4B	EQ_COEF_2F2_B1	0x6B	EQ_COEF_3F2_B1
0x0C	EQ_COEF_0F2_B2	0x2C	EQ_COEF_1F2_B2	0x4C	EQ_COEF_2F2_B2	0x6C	EQ_COEF_3F2_B2
0x0D	EQ_COEF_0F2_A1	0x2D	EQ_COEF_1F2_A1	0x4D	EQ_COEF_2F2_A1	0x6D	EQ_COEF_3F2_A1
0x0E	EQ_COEF_0F2_A2	0x2E	EQ_COEF_1F2_A2	0x4E	EQ_COEF_2F2_A2	0x6E	EQ_COEF_3F2_A2
0x0F	EQ_COEF_0F3_B0	0x2F	EQ_COEF_1F3_B0	0x4F	EQ_COEF_2F3_B0	0x6F	EQ_COEF_3F3_B0
0x10	EQ_COEF_0F3_B1	0x30	EQ_COEF_1F3_B1	0x50	EQ_COEF_2F3_B1	0x70	EQ_COEF_3F3_B1
0x11	EQ_COEF_0F3_B2	0x31	EQ_COEF_1F3_B2	0x51	EQ_COEF_2F3_B2	0x71	EQ_COEF_3F3_B2
0x12	EQ_COEF_0F3_A1	0x32	EQ_COEF_1F3_A1	0x52	EQ_COEF_2F3_A1	0x72	EQ_COEF_3F3_A1
0x13	EQ_COEF_0F3_A2	0x33	EQ_COEF_1F3_A2	0x53	EQ_COEF_2F3_A2	0x73	EQ_COEF_3F3_A2
0x14	EQ_COEF_0F4_B0	0x34	EQ_COEF_1F4_B0	0x54	EQ_COEF_2F4_B0	0x74	EQ_COEF_3F4_B0
0x15	EQ_COEF_0F4_B1	0x35	EQ_COEF_1F4_B1	0x55	EQ_COEF_2F4_B1	0x75	EQ_COEF_3F4_B1
0x16	EQ_COEF_0F4_B2	0x36	EQ_COEF_1F4_B2	0x56	EQ_COEF_2F4_B2	0x76	EQ_COEF_3F4_B2
0x17	EQ_COEF_0F4_A1	0x37	EQ_COEF_1F4_A1	0x57	EQ_COEF_2F4_A1	0x77	EQ_COEF_3F4_A1
0x18	EQ_COEF_0F4_A2	0x38	EQ_COEF_1F4_A2	0x58	EQ_COEF_2F4_A2	0x78	EQ_COEF_3F4_A2
0x19	EQ_COEF_0F5_B0	0x39	EQ_COEF_1F5_B0	0x59	EQ_COEF_2F5_B0	0x79	EQ_COEF_3F5_B0
0x1A	EQ_COEF_0F5_B1	0x3A	EQ_COEF_1F5_B1	0x5A	EQ_COEF_2F5_B1	0x7A	EQ_COEF_3F5_B1
0x1B	EQ_COEF_0F5_B2	0x3B	EQ_COEF_1F5_B2	0x5B	EQ_COEF_2F5_B2	0x7B	EQ_COEF_3F5_B2
0x1C	EQ_COEF_0F5_A1	0x3C	EQ_COEF_1F5_A1	0x5C	EQ_COEF_2F5_A1	0x7C	EQ_COEF_3F5_A1
0x1D	EQ_COEF_0F5_A2	0x3D	EQ_COEF_1F5_A2	0x5D	EQ_COEF_2F5_A2	0x7D	EQ_COEF_3F5_A2
0x1E	-	0x3E	-	0x5E	-	0x7E	-
0x1F	EQ_PRESCALE0	0x3F	EQ_PRESCALE1	0x5F	EQ_PRESCALE2	0x7F	EQ_PRESCALE3

Table 16: DACGRAM Bass/Treble/3D and multiband compressor Addresses

Addr	Bass	Addr	Treble	Addr	3D	Addr	Multiband
	Coefficients		Coefficients		Coefficients		Coefficients
0x80	BASS_COEF_EXT1_B0	0x97	TREB_COEF_EXT1_B0	0xAE	3D_COEF	0xB0	MBC1_BQ1_COEFF0
0x81	BASS_COEF_EXT1_B1	0x98	TREB_COEF_EXT1_B1	0xAF	3D_MIX	0xB1	MBC1_BQ1_COEFF1
0x82	BASS_COEF_EXT1_B2	0x99	TREB_COEF_EXT1_B2			0xB2	MBC1_BQ1_COEFF2
0x83	BASS_COEF_EXT1_A1	0x9A	TREB_COEF_EXT1_A1			0xB3	MBC1_BQ1_COEFF3
0x84	BASS_COEF_EXT1_A2	0x9B	TREB_COEF_EXT1_A2			0xB4	MBC1_BQ1_COEFF4
0x85	BASS_COEF_EXT2_B0	0x9C	TREB_COEF_EXT2_B0			0xB5	MBC1_BQ2_COEFF0
0x86	BASS_COEF_EXT2_B1	0x9D	TREB_COEF_EXT2_B1			0xB6	MBC1_BQ2_COEFF1
0x87	BASS_COEF_EXT2_B2	0x9E	TREB_COEF_EXT2_B2			0xB7	MBC1_BQ2_COEFF2
0x88	BASS_COEF_EXT2_A1	0x9F	TREB_COEF_EXT2_A1			0xB8	MBC1_BQ2_COEFF3
0x89	BASS_COEF_EXT2_A2	0xA0	TREB_COEF_EXT2_A2			0xB9	MBC1_BQ2_COEFF4
0x8A	BASS_COEF_NLF_M1	0xA1	TREB_COEF_NLF_M1			0xBA	MBC2_BQ1_COEFF0
0x8B	BASS_COEF_NLF_M2	0xA2	TREB_COEF_NLF_M2			0xBB	MBC2_BQ1_COEFF1
0x8C	BASS_COEF_LMT_B0	0xA3	TREB_COEF_LMT_B0			0xBC	MBC2_BQ1_COEFF2
0x8D	BASS_COEF_LMT_B1	0xA4	TREB_COEF_LMT_B1			0xBD	MBC2_BQ1_COEFF3
0x8E	BASS_COEF_LMT_B2	0xA5	TREB_COEF_LMT_B2			0xBE	MBC2_BQ1_COEFF4
0x8F	BASS_COEF_LMT_A1	0xA6	TREB_COEF_LMT_A1			0xBF	MBC2_BQ2_COEFF0
0x90	BASS_COEF_LMT_A2	0xA7	TREB_COEF_LMT_A2			0xC0	MBC2_BQ2_COEFF1
0x91	BASS_COEF_CTO_B0	0xA8	TREB_COEF_CTO_B0			0xC1	MBC2_BQ2_COEFF2
0x92	BASS_COEF_CTO_B1	0xA9	TREB_COEF_CTO_B1			0xC2	MBC2_BQ2_COEFF3
0x93	BASS_COEF_CTO_B2	0xAA	TREB_COEF_CTO_B2			0xC3	MBC2_BQ2_COEFF4
0x94	BASS_COEF_CTO_A1	0xAB	TREB_COEF_CTO_A1			0xC4	MBC3_BQ1_COEFF0
0x95	BASS_COEF_CTO_A2	0xAC	TREB_COEF_CTO_A2			0xC5	MBC3_BQ1_COEFF1
0x96	BASS_MIX	0xAD	TREB_MIX			0xC6	MBC3_BQ1_COEFF2
						0xC7	MBC3_BQ1_COEFF3
						0xC8	MBC3_BQ1_COEFF4
						0xC9	MBC3_BQ2_COEFF0
						0xCA	MBC3_BQ2_COEFF1
						0xCB	MBC3_BQ2_COEFF2
						0xCC	MBC3_BQ2_COEFF3
						0xCD	MBC3_BQ2_COEFF4

1. All B0 coefficients are set to unity (400000h) by default. All others, including M1 and M2, are 0 by default.
2. NLF coefficients (M1, M2) have a range defined as +/-8, with 1 sign bit, 3 integer bits, and 20 fraction bits. So, unity for these values is 100000h. This is as opposed to the rest of the coefficient RAM, which has a range defined as +/-2, with 1 sign bit, 1 integer bit, and 22 fraction bits.

3.5. Gain and Dynamic Range Control

The gain for a given channel is controlled by the MVOL, HPVOL, SPKVOL, and SUB/EARVOL registers. If the result of the gain multiply step would result in overflow of the output word width, the output is saturated at the max positive or negative value. In addition to simple gain control, the TSC42XX also provides sophisticated dynamic range control including limiting, dynamic range compression, and dynamic range expansion functions.

3.6. Limiter

The Limiter function will limit the output of the DSP module to the Class-D and DAC modules. If the signal is greater than 0dB it will saturate at 0dB as the final processing step within the DSP module.

There are times when the user may intentionally want the output Limiter to perform this saturation, for example +6dB of gain applied within the DSP gain control and then limited to 0dB when output to the Class-D module would result in a clipped signal driving the Speaker output. This clipped signal would obviously contribute to increased distortion on the Speaker output which from the user listening perception it would “sound louder”.

At other times, the system implementor may wish to protect speakers from overheating or provide hearing protection by intentionally limiting the output level before full scale is reached. A limit threshold, independent of the compressor threshold is provided for this purpose. It is expected that the limit threshold is set to a higher level than the compressor threshold.

3.7. Multi-band Compressor

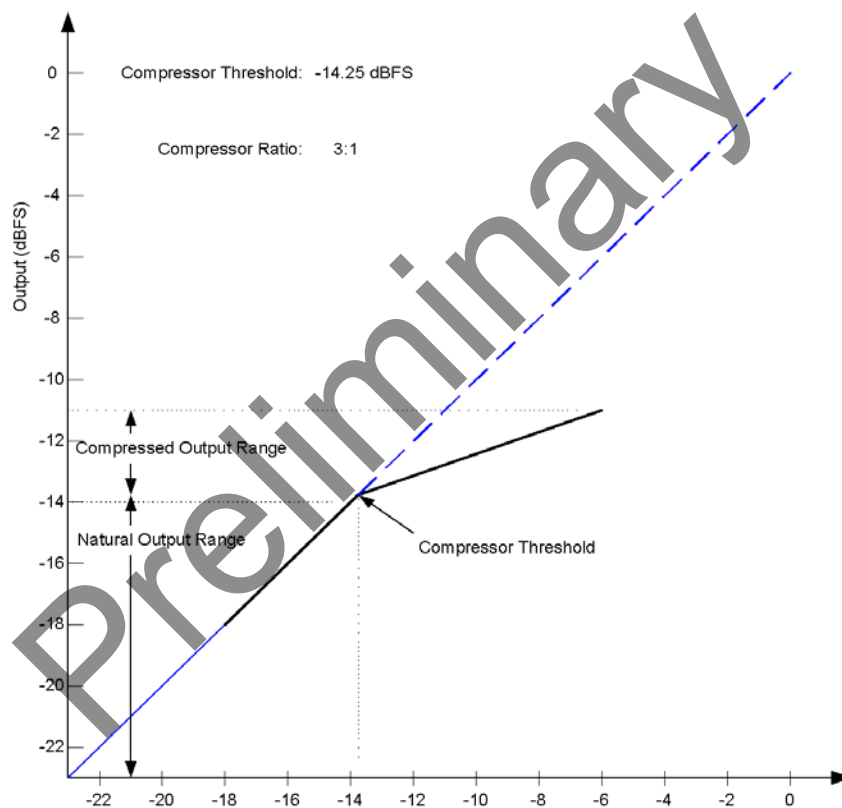

Figure 6. Gain Compressor, Output vs Input

3.7.1. Overview

The TSCS42XX output processing includes a multi-band compressor that improves sound from small loudspeakers typically used in portable devices. Three independent compressor blocks are each preceded by a Bi-quad processing block that filters the incoming audio so that each compressor operates on a select range of audio frequencies. The advantage of multiband compression over full-bandwidth (full-band, or single-band) compression is that audible gain “pumping” can be reduced. When using single band compressors high energy audio content in a narrow range of frequencies can cause the volume of the entire audio frequency band to be affected thus causing the audio signal level to audibly “pump”. This pumping of the audio signal level can be distracting. A multi-band compressor can effectively eliminate or reduce the pumping to insignificant levels.

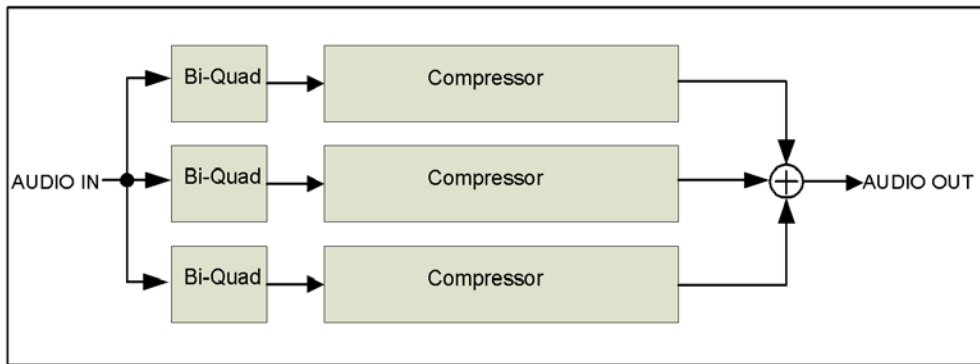

Figure 7. block digram Multiband compressor

Each band in the Multi-band Compressor is comprised of a single stage 6-tap IIR (Bi-quad) filter followed by a compressor block. The BI-quad filter coefficients are written using the Parametric Equalizer Registers. The purpose of the Bi-quad block is to provide a bandpass filter function for each Compressor band.

A basic block diagram of the compressor is shown below:

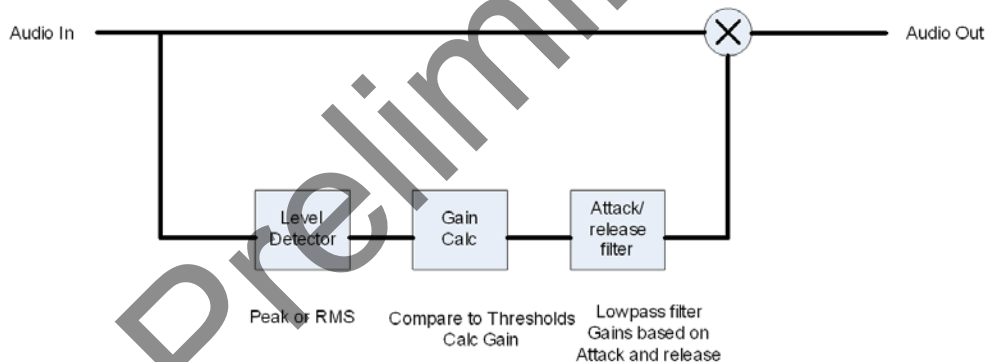

Figure 8. Compressor block diagram

As this diagram shows, there are 3 primary components of the compressor.

1. **Level Detector:** The level detector, detects the level of the incoming signal. Since the comp/limiter is designed to work on blocks of signals, the level detector will either find the peak value of the block of samples to be processed or the rms level of the samples within a block.
2. **Gain Calculation:** The gain calculation block is responsible for taking the output of the level detector and calculating a target gain based on that level and the compressor and expander Compression region gain calculation: In the compression region, the gain calculation is:

$$\text{Atten(in db)} = (1-1/\text{ratio})(\text{threshold(in db)} - \text{level(in db)});$$

- For example,
 - Ratio = 4:1 compression
 - Threshold = -16db
 - Level = -4 db

The required attenuation is: 9db or a gain coefficient of 0.1259.

Translating this calculation from log space to linear yields the formula:

$$\text{Gain} = (\text{level}/\text{threshold})^{1/\text{ratio}} * (\text{threshold}/\text{level})$$

- **State Transitions:** In addition to calculating the new gain for the compressor, the gain calculation block will also select the filter coefficient for the attack/release filter. The rules for selecting the coefficient are as follows:

In the compression region:

- If the gain calculated is less than the last gain calculated (more compression is being applied), then the filter coefficient is the compressor attack.
- If the gain calculated is more than the last gain calculated (less compression), the filter coefficient is the compressor release.

In the linear region:

- Modify gain until a gain of 1.0 is obtained, using the compressor release.

3. **Attack/Release filter:** In order to prevent objectionable artifacts, the gain is smoothly ramped from the current value to the new value calculated by the gain calculation block. In the PC-based comp/limiter, this is achieved using a simple tracking lowpass filter to smooth out the abrupt transitions. The calculation (using the coefficient (coeff) selected by the gain block) is:

$$\text{Filtered_gain} = \text{coeff} * \text{last_filtered_gain} + (1.0 - \text{coeff}) * \text{target_gain};$$

This creates an exponential ramp from the current gain value to the new value.

Table 17. DAC_Multi-band_Compressor Enable (MBCEN) Register

Register Address	Bit	Label	Type	Default	Description
Reg 199 - C7 DACMBCEN	7:3	RSVD	R	0h	Reserved
	2	MBCEN3	RW	0	1 = enable compressor band 3
	1	MBCEN2	RW	0	1 = enable compressor band 2
	0	MBCEN1	RW	0	1 = enable compressor band 1

Table 18. DAC_Multi-band_Compressor Control (MBCCTL) Register

Register Address	Bit	Label	Type	Default	Description
Reg 200 - C8 DACMBCCTL	7:6	RSVD	R	0h	Reserved
	5	LVLMODE3	RW	0	Compressor Level Detection Mode Band 3 0 = Average 1 = Peak
	4	WINSEL3	RW	0	Window width selection for level detection Band 3 0 = equivalent of 512 samples of selected Base Rate (~10-16ms) 1 = equivalent of 64 samples of selected Base Rate (~1.3-2ms)
	3	LVLMODE2	RW	0	Compressor Level Detection Mode Band 2 0 = Average 1 = Peak
	2	WINSEL2	RW	0	Window width selection for level detection Band 2 0 = equivalent of 512 samples of selected Base Rate (~10-16ms) 1 = equivalent of 64 samples of selected Base Rate (~1.3-2ms)
	1	LVLMODE1	RW	0	Compressor Level Detection Mode Band 1 0 = Average 1 = Peak
	0	WINSEL1	RW	0	Window width selection for level detection Band 1 0 = equivalent of 512 samples of selected Base Rate (~10-16ms) 1 = equivalent of 64 samples of selected Base Rate (~1.3-2ms)

Table 19. DAC_Multi-band_Compressor Make-up Gain Band 1(MBCMUG1) Register

Register Address	Bit	Label	Type	Default	Description
Reg 201 - C9 DACMBCMUG1	7:5	RSVD	R	0h	Reserved
	5	PHASE	RW	0h	0 = not inverted 1 = Inverted
	4:0	MUGAIN[4:0]	RW	0h	0dB...46.5dB in 1.5dB steps

Table 20. DAC_Multi-band_Compressor Threshold Band 1(MBCTHR1) Register

Register Address	Bit	Label	Type	Default	Description
Reg 202 - CA DACMBCTHR1	7:0	THRESH[7:0]	RW	00h	FFh...00h = 0dB...95.625dB in 0.375dB steps.

Table 21. DAC_Multi-band_Compression Ratio Band 1(MBCRAT1) Register

Register Address	Bit	Label	Type	Default	Description
Reg 203 - CB DACMBCRAT1	7:5	RSVD	R	000	Reserved
	4:0	RATIO[4:0]	RW	00h	Compressor Ratio 00h = Reserved 01h = 1.5:1 02h...14h = 2:1...20:1 15h...1Fh = Reserved

Table 22. DAC_Multi-band_Compressor Attack Time Constant Band 1(MBCATK1L) Register (Low)

Register Address	Bit	Label	Type	Default	Description
Reg 204 - CC DACMBCATK1L	7:0	TCATKL[7:0]	RW	00h	Low byte of the time constant used to ramp to a new gain value during a compressor attack phase. 0000h = 0 (instantaneous) 0001h = $0.96875 + 1/(2^{21})$ 0002h = $0.96875 + 2/(2^{21})$... (step = $1/(2^{21})$) FFFEh = $[(2^{21})-2]/(2^{21})$ FFFFh = $[(2^{21})-1]/(2^{21})$

Table 23. DAC_Multi-band_Compressor Attack Time Constant Band 1(MBCATK1H) Register (High)

Register Address	Bit	Label	Type	Default	Description
Reg 205 - CD DACMBCATK1H	7:0	TCATKH[7:0]	RW	00h	High byte of the time constant used to ramp to a new gain value during a compressor attack phase. 0000h = 0 (instantaneous) 0001h = $0.96875 + 1/(2^{21})$ 0002h = $0.96875 + 2/(2^{21})$... (step = $1/(2^{21})$) FFFEh = $[(2^{21})-2]/(2^{21})$ FFFFh = $[(2^{21})-1]/(2^{21})$

Table 24. DAC_Multi-band_Compressor Release Time Constant Band 1(MBCREL1L) Register (Low)

Register Address	Bit	Label	Type	Default	Description
Reg 206 - CE DACMBCREL1L	7:0	TCRELL[7:0]	RW	00h	Low byte of the time constant used to ramp to a new gain value during a compressor release phase. 0000h = 0 (instantaneous) 0001h = $0.96875 + 1/(2^{21})$ 0002h = $0.96875 + 2/(2^{21})$... (step = $1/(2^{21})$) FFFEh = $[(2^{21})-2]/(2^{21})$ FFFFh = $[(2^{21})-1]/(2^{21})$

Table 25. DAC_Multi-band_Compressor Release Time Constant Band 1(MBCREL1H) Register (High)

Register Address	Bit	Label	Type	Default	Description
Reg 207 - CF DACMBCREL1H	7:0	TCRELH[15:8]	RW	00h	High byte of the time constant used to ramp to a new gain value during a compressor release phase. The time constant is [high byte, low byte] 0000h = 0 (instantaneous) 0001h = $0.96875 + 1/(2^{21})$ 0002h = $0.96875 + 2/(2^{21})$... (step = $1/(2^{21})$) FFFEh = $[(2^{21})-2]/(2^{21})$ FFFFh = $[(2^{21})-1]/(2^{21})$

Table 26. DAC_Multi-band_Compressor Make-up Gain Band 2(MBCMUG2) Register

Register Address	Bit	Label	Type	Default	Description
Reg 208 - D0 DACMBCMUG2	7:6	RSVD	R	0h	Reserved
	5	PHASE	RW	0h	0 = not inverted 1 = Inverted
	4:0	MUGAIN[4:0]	RW	0h	0dB...46.5dB in 1.5dB steps

Table 27. DAC_Multi-band_Compressor Threshold Band 2(MBCTHR2) Register

Register Address	Bit	Label	Type	Default	Description
Reg 209 - D1 DACMBCTHR2	7:0	THRESH[7:0]	RW	00h	FFh...00h = 0dB...95.625dB in 0.375dB steps.

Table 28. DAC_Multi-band_Compression Ratio Band 2(MBCRAT2) Register

Register Address	Bit	Label	Type	Default	Description
Reg 210 - D2 DACMBCRAT2	7:5	RSVD	R	000	Reserved
	4:0	RATIO[4:0]	RW	00h	Compressor Ratio 00h = Reserved 01h = 1.5:1 02h...14h = 2:1...20:1 15h...1Fh = Reserved

Table 29. DAC_Multi-band_Compressor Attack Time Constant Band 2(MBCATK2L) Register (Low)

Register Address	Bit	Label	Type	Default	Description
Reg 211 - D3 DACMBCATK2L	7:0	TCATKL[7:0]	RW	00h	Low byte of the time constant used to ramp to a new gain value during a compressor attack phase. 0000h = 0 (instantaneous) 0001h = $0.96875 + 1/(2^{21})$ 0002h = $0.96875 + 2/(2^{21})$... (step = $1/(2^{21})$) FFFEh = $[(2^{21})-2]/(2^{21})$ FFFFh = $[(2^{21})-1]/(2^{21})$

Table 30. DAC_Multi-band_Compressor Attack Time Constant Band 2(MBCATK2H) Register (High)

Register Address	Bit	Label	Type	Default	Description
Reg 212 - D4 DACMBCATK2H	7:0	TCATKH[7:0]	RW	00h	High byte of the time constant used to ramp to a new gain value during a compressor attack phase. 0000h = 0 (instantaneous) 0001h = $0.96875 + 1/(2^{21})$ 0002h = $0.96875 + 2/(2^{21})$... (step = $1/(2^{21})$) FFFEh = $[(2^{21})-2]/(2^{21})$ FFFFh = $[(2^{21})-1]/(2^{21})$

Table 31. DAC_Multi-band_Compressor Release Time Constant Band 2(MBCREL2L) Register (Low)

Register Address	Bit	Label	Type	Default	Description
Reg 213 - D5 DACMBCREL2L	7:0	TCRELL[7:0]	RW	00h	Low byte of the time constant used to ramp to a new gain value during a compressor release phase. 0000h = 0 (instantaneous) 0001h = $0.96875 + 1/(2^{21})$ 0002h = $0.96875 + 2/(2^{21})$... (step = $1/(2^{21})$) FFFEh = $[(2^{21})-2]/(2^{21})$ FFFFh = $[(2^{21})-1]/(2^{21})$

Table 32. DAC_Multi-band_Compressor Release Time Constant Band 2(MBCREL2H) Register (High)

Register Address	Bit	Label	Type	Default	Description
Reg 214 - D6 DACMBCREL2H	7:0	TCREL[15:8]	RW	00h	High byte of the time constant used to ramp to a new gain value during a compressor release phase. The time constant is [high byte, low byte] 0000h = 0 (instantaneous) 0001h = $0.96875 + 1/(2^{21})$ 0002h = $0.96875 + 2/(2^{21})$... (step = $1/(2^{21})$) FFFEh = $[(2^{21})-2]/(2^{21})$ FFFFh = $[(2^{21})-1]/(2^{21})$

Table 33. DAC_Multi-band_Compressor Make-up Gain Band 3(MBCMUG3) Register

Register Address	Bit	Label	Type	Default	Description
Reg 215 - D7 DACMBCMUG3	7:5	RSVD	R	0h	Reserved
	5	PHASE	RW	0h	0 = not inverted 1 = Inverted
	4:0	MUGAIN[4:0]	RW	0h	0dB...46.5dB in 1.5dB steps

Table 34. DAC_Multi-band_Compressor Threshold Band 3(MBCTHR3) Register

Register Address	Bit	Label	Type	Default	Description
Reg 216 - D8 DACMBCTHR3	7:0	THRESH[7:0]	RW	00h	FFh...00h = 0dB...95.625dB in 0.375dB steps.

Table 35. DAC_Multi-band_Compression Ratio Band 3(MBCMRAT3) Register

Register Address	Bit	Label	Type	Default	Description
Reg 217 - D9 DACMBCRAT3	7:5	RSVD	R	000	Reserved
	4:0	RATIO[4:0]	RW	00h	Compressor Ratio 00h = Reserved 01h = 1.5:1 02h...14h = 2:1...20:1 15h...1Fh = Reserved

Table 36. DAC_Multi-band_Compressor Attack Time Constant Band 3(MBCATK3L) Register (Low)

Register Address	Bit	Label	Type	Default	Description
Reg 218 - DA DACMBCATK3L	7:0	TCATKL[7:0]	RW	00h	Low byte of the time constant used to ramp to a new gain value during a compressor attack phase. 0000h = 0 (instantaneous) 0001h = $0.96875 + 1/(2^{21})$ 0002h = $0.96875 + 2/(2^{21})$... (step = $1/(2^{21})$) FFFEh = $[(2^{21})-2]/(2^{21})$ FFFFh = $[(2^{21})-1]/(2^{21})$

Table 37. DAC_Multi-band_Compressor Attack Time Constant Band 3(MBCATK3H) Register (High)

Register Address	Bit	Label	Type	Default	Description
Reg 219 - DB DACMBCATK3H	7:0	TCATKHH[7:0]	RW	00h	High byte of the time constant used to ramp to a new gain value during a compressor attack phase. 0000h = 0 (instantaneous) 0001h = $0.96875 + 1/(2^{21})$ 0002h = $0.96875 + 2/(2^{21})$... (step = $1/(2^{21})$) FFFEh = $[(2^{21})-2]/(2^{21})$ FFFFh = $[(2^{21})-1]/(2^{21})$

Table 38. DAC_Multi-band_Compressor Release Time Constant Band 3(MBCREL3L) Register (Low)

Register Address	Bit	Label	Type	Default	Description
Reg 220 - DC DACMBCREL3L	7:0	TCRELL[7:0]	RW	00h	Low byte of the time constant used to ramp to a new gain value during a compressor release phase. 0000h = 0 (instantaneous) 0001h = $0.96875 + 1/(2^{21})$ 0002h = $0.96875 + 2/(2^{21})$... (step = $1/(2^{21})$) FFFEh = $[(2^{21})-2]/(2^{21})$ FFFFh = $[(2^{21})-1]/(2^{21})$

Table 39. DAC_Multi-band_Compressor Release Time Constant Band 3(MBCREL3H) Register (High)

Register Address	Bit	Label	Type	Default	Description
Reg 221 - DD DACMBCREL3H	7:0	TCRELH[15:8]	RW	00h	High byte of the time constant used to ramp to a new gain value during a compressor release phase. The time constant is [high byte, low byte] 0000h = 0 (instantaneous) 0001h = $0.96875 + 1/(2^{21})$ 0002h = $0.96875 + 2/(2^{21})$... (step = $1/(2^{21})$) FFFEh = $[(2^{21})-2]/(2^{21})$ FFFFh = $[(2^{21})-1]/(2^{21})$

3.8. Limiter/Compressor Registers

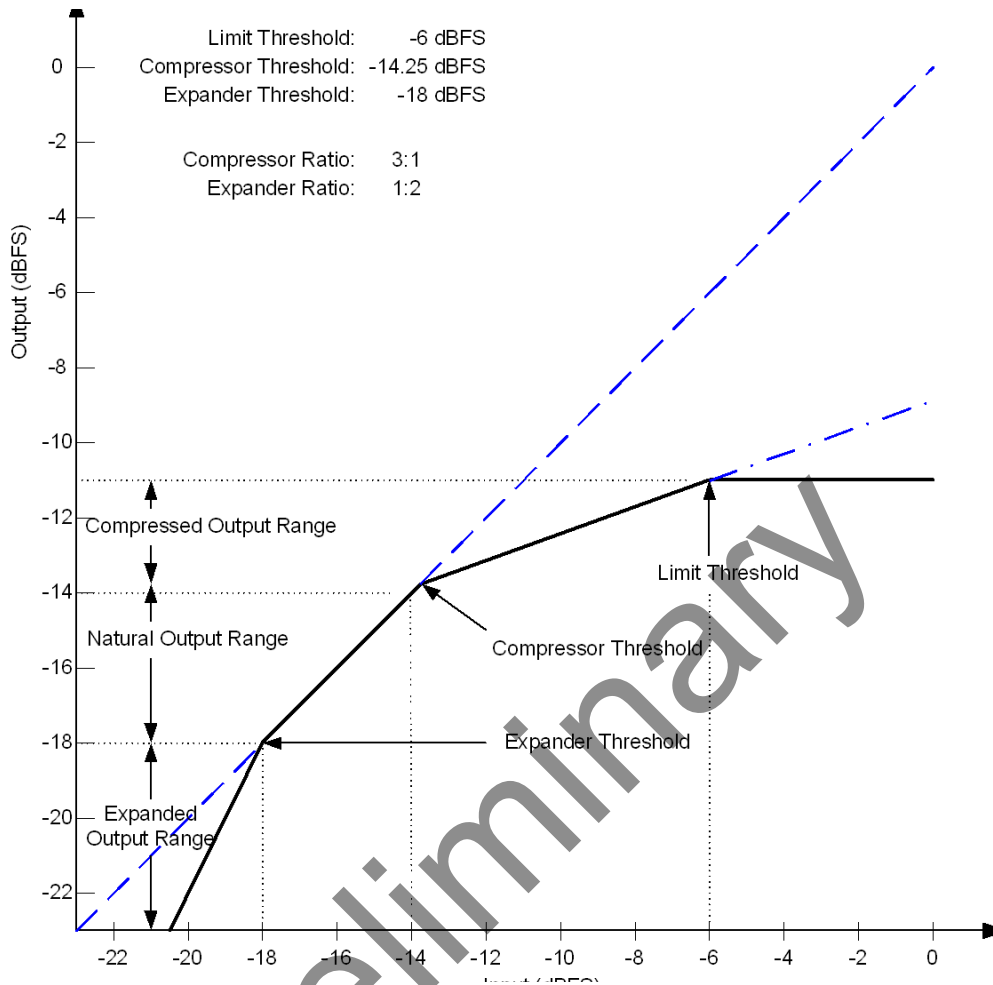

Figure 9. Gain Compressor, Output vs Input

The traditional compressor algorithm provides two functions simultaneously (depending on signal level). For higher level signals, it can provide a compression function to reduce the signal level. For lower level signals, it can provide an expansion function for either increasing dynamic range or noise gating.

The compressor monitors the signal level and, if the signal is higher than a threshold, will reduce the gain by a programmed ratio to restrict the dynamic range. Limiting is an extreme example of the compressor where, as the input signal level is increased, the gain is decreased to maintain a specific output level.

In addition to limiting the bandwidth of the compressed audio, it is common for compressed audio to also compress the dynamic range of the audio. The expansion function in TSC42XX can help restore the original dynamics to the audio.

The expander is a close relative of the compressor. Rather than using signal dependent gain to restrict the dynamic range, the expander uses signal dependent gain to expand the dynamic range. Thus if a signal level is below a particular threshold, the expander will reduce the gain even further to extend the dynamic range of the material.

3.8.1. Configuration

This compressor limiter provides the following configurable parameters.

- Compressor/limiter
 - Threshold – The threshold above which the compressor will reduce the dynamic range of the audio in the compression region.
 - Ratio – The ratio between the input dynamic range and the output dynamic range. For example, a ratio of 3 will reduce an input dynamic range of 9db to 3db.
 - Attack Time – The amount of time that changes in gain are smoothed over during the attack phase of the compressor.
 - Release Time – The amount of time that changes in gain are smoothed over during the release phase of the compressor.
 - Makeup gain – Used to increase the overall level of the compressed audio.
- Expander
 - Threshold – The threshold below which the expander will increase the dynamic range of the audio.
 - Ratio – The ratio between the input dynamic range and the output dynamic range of the audio in the expansion range. For example a ratio of 3 will take an input dynamic range of 9db and expand it to 27db.
 - Attack Time – The amount of time that changes in gain are smoothed over during the attack phase of the expander
 - Release Time
 - - The amount of time that changes in gain are smoothed over during the release phase of the expander.
- Two level detection algorithms
 - RMS – Use an RMS measurement for the level.
 - Peak – Use a peak measurement for the level.

3.8.2. Controlling parameters

In order to control this processing, there are a number of configurable parameters. The parameters and their ranges are:

- Compressor/limiter
 - Threshold – -40db to 0db relative to full scale.
 - Ratio – 1 to 20
 - Attack Time – typically 0 to 500ms
 - Release Time – typically 25ms to 2 seconds
 - Makeup gain – 0 to 40db
- Expander
 - Threshold – -30 to -60 dB
 - Ratio – 1 to 6
 - Attack Time – same as above
 - Release Time – same as above.
- Two level detection algorithms
 - RMS
 - Peak

3.8.3. CLECTL Register

General compressor/limiter/expander control

Register Address	Bit	Label	Type	Default	Description
R37 (25h) CLECTL	7:5	RSVD	R	0h	Reserved
	4	Lvl_Mode	RW	0	CLE Level Detection Mode 0 = Average 1 = Peak
	3	WindowSel	RW	0	Window width selection for level detection: 0 = equivalent of 512 samples of selected Base Rate (~10-16ms) 1 = equivalent of 64 samples of selected Base Rate (~1.3-2ms)
	2	Exp_en	RW	0	1 = enable expander
	1	Limit_en	RW	0	1 = enable limiter
	0	Comp_en	RW	0	1 = enable compressor

Table 40. CLECTL Register**3.8.4. MUGAIN Register**

Compressor/Limiter/Expander make-up gain

Register Address	Bit	Label	Type	Default	Description
R38 (26h) MUGAIN	7:5	RSVD	R	0h	Reserved
	4:0	CLEMUG[4:0]	RW	0h	0dB...46.5dB in 1.5dB steps

Table 41. MUGAIN Register**3.8.5. COMPTHRESH Register**

Compressor Threshold Register

Register Address	Bit	Label	Type	Default	Description
R39 (27h) COMPTH	7:0	COMPTH[7:0]	RW	00h	FFh...00h = 0dB...95.625dB in 0.375dB steps.

Table 42. COMPTHRESH Register

3.8.6. COMP_RATIO Register

Compressor ration register

Register Address	Bit	Label	Type	Default	Description
R40 (28h) CMPRAT	7:5	RSVD	R	000	Reserved
	4:0	CMPRAT[4:0]	RW	00h	Compressor Ratio 00h = Reserved 01h = 1.5:1 02h...14h = 2:1...20:1 15h...1Fh = Reserved

Table 43. COMP_RATIO Register

3.8.7. COMPATKTC_Low Register

Compressor Attack Time Constant Register (Low)

Register Address	Bit	Label	Type	Default	Description
R41 (29h) CATKTCL	7:0	CATKTC[7:0]	RW	00h	Low byte of the time constant used to ramp to a new gain value during a compressor attack phase.

Table 44. COMPATKTC_Low Register

3.8.8. COMPATKTC_HI Register

Compressor Attack Time Constant Register (High)

Register Address	Bit	Label	Type	Default	Description
R42 (2Ah) CATKTCH	7:0	CATKTC[15:8]	RW	00h	High byte of the time constant used to ramp to a new gain value during a compressor attack phase. The time constant is [high byte, low byte] 0000h = 0 (instantaneous) 0001h = $0.96875 + 1/(2^{21})$ 0002h = $0.96875 + 2/(2^{21})$... (step = $1/(2^{21})$) FFFEh = $[(2^{21})-2]/(2^{21})$ FFFFh = $[(2^{21})-1]/(2^{21})$

Table 45. COMPATKTC_HI Register

3.8.9. COMPRELTC_Low Register

Compressor Release Time Constant Register (Low)

Register Address	Bit	Label	Type	Default	Description
R43 (2Bh) CRELTCL	7:0	CRELTC[7:0]	RW	00h	Low byte of the time constant used to ramp to a new gain value during a compressor release phase.

Table 46. OMPRELTC_Low Register

3.8.10. COMPRELTC_HI Register

Compressor Release Time Constant Register (High)

Register Address	Bit	Label	Type	Default	Description
R44 (2Ch) CRELTCH	7:0	CRELTC[15:8]	RW	00h	High byte of the time constant used to ramp to a new gain value during a compressor release phase. The time constant is [high byte, low byte] 0000h = 0 (instantaneous) 0001h = $0.96875 + 1/(2^{21})$ 0002h = $0.96875 + 2/(2^{21})$... (step = $1/(2^{21})$) FFFEh = $[(2^{21})-2]/(2^{21})$ FFFFh = $[(2^{21})-1]/(2^{21})$

Table 47. COMPRELTC_HI Register

3.8.11. LIMTHRESH Register

Table 48. Limiter Threshold Register

Register Address	Bit	Label	Type	Default	Description
R45 (2Dh) LIMTH	7:0	LIMTH[7:0]	RW	00h	FFh...00h = 0dB...95.625dB in 0.375dB steps.

3.8.12. LIMTARGET Register

Table 49. Limiter Threshold Register

Register Address	Bit	Label	Type	Default	Description
R46 (2Eh) LIMTGT	7:0	LIMTGT[7:0]	RW	00h	FFh...00h = 0dB...95.625dB in 0.375dB steps.

3.8.13. LIMATKTC_Low Register

Table 50. Limiter Attack Time Constant Register (Low)

Register Address	Bit	Label	Type	Default	Description
R47 (2Fh) LATKTCL	7:0	LATKTC[7:0]	RW	00h	Low byte of the time constant used to ramp to a new gain value during a limiter attack phase.

3.8.14. LIMATKTC_High Register

Table 51. Limiter Attack Time Constant Register (High)

Register Address	Bit	Label	Type	Default	Description
R48 (30h) LATKTCH	7:0	LATKTC[15:8]	RW	00h	High byte of the time constant used to ramp to a new gain value during a limiter attack phase. The time constant is [high byte, low byte] 0000h = 0 (instantaneous) 0001h = $0.96875 + 1/(2^{21})$ 0002h = $0.96875 + 2/(2^{21})$... (step = $1/(2^{21})$) FFFEh = $[(2^{21})-2]/(2^{21})$ FFFFh = $[(2^{21})-1]/(2^{21})$

3.8.15. LIMRELTC_Low Register

Table 52. Limiter Release Time Constant Register (Low)

Register Address	Bit	Label	Type	Default	Description
R49 (31h) LRELTCCL	7:0	LRELTC[7:0]	RW	00h	Low byte of the time constant used to ramp to a new gain value during a limiter release phase.

3.8.16. LIMRELTC_High Register

Table 53. Limiter Release Time Constant Register (High)

Register Address	Bit	Label	Type	Default	Description
R50 (32h) LRELTCCH	7:0	LRELTC[15:8]	RW	00h	High byte of the time constant used to ramp to a new gain value during a limiter release phase. The time constant is [high byte, low byte] 0000h = 0 (instantaneous) 0001h = $0.96875 + 1/(2^{21})$ 0002h = $0.96875 + 2/(2^{21})$... (step = $1/(2^{21})$) FFFEh = $[(2^{21})-2]/(2^{21})$ FFFFh = $[(2^{21})-1]/(2^{21})$

3.8.17. Expander Registers

Table 54. Expander Threshold Register

Register Address	Bit	Label	Type	Default	Description
R51 (33h) EXPTH	7:0	EXPTH[7:0]	RW	00h	Expander threshold: 0...95.625dB in 0.375dB steps

3.8.18. Expander Ratio Register

Table 55. Expander Ratio Register

Register Address	Bit	Label	Type	Default	Description
R52 (34h) EXPRAT	7:3	RSVD	R	00h	Reserved
		EXPRAT[2:0]	RW	000	Expander Ratio 0h...1h = Reserved 2h...7h = 1:2...1:7

3.8.19. EXPATKTC_Low Register

Table 56. Expander Attack Time Constant Register (Low)

Register Address	Bit	Label	Type	Default	Description
R53 (35h) XATKTCL	7:0	XATKTC[7:0]	RW	00h	Low byte of the time constant used to ramp to a new gain value during a expander attack phase.

3.8.20. EXPATKTC_High Register

Table 57. Expander Attack Time Constant Register (High)

Register Address	Bit	Label	Type	Default	Description
R54 (36h) XATKTCH	7:0	XATKTC[15:8]	RW	00h	High byte of the time constant used to ramp to a new gain value during a expander attack phase. The time constant is [high byte, low byte] 0000h = 0 (instantaneous) 0001h = $0.96875 + 1/(2^{21})$ 0002h = $0.96875 + 2/(2^{21})$... (step = $1/(2^{21})$) FFFEh = $[(2^{21})-2]/(2^{21})$ FFFFh = $[(2^{21})-1]/(2^{21})$

3.8.21. EXPRELTC_Low Register

Table 58. Expander Release Time Constant Register (Low)

Register Address	Bit	Label	Type	Default	Description
R55 (37h) XRELTCL	7:0	XRELTCL[7:0]	RW	0	Low byte of the time constant used to ramp to a new gain value during a expander release phase.

3.8.22. EXPRELTC_High Register

Table 59. Expander Release Time Constant Register (High)

Register Address	Bit	Label	Type	Default	Description
R56 (38h) XRELTC	7:0	XRELTC[15:8]	RW	0	High byte of the time constant used to ramp to a new gain value during a expander release phase. The time constant is [high byte, low byte] 0000h = 0 (instantaneous) 0001h = $0.96875 + 1/(2^{21})$ 0002h = $0.96875 + 2/(2^{21})$... (step = $1/(2^{21})$) FFFEh = $[(2^{21})-2]/(2^{21})$ FFFFh = $[(2^{21})-1]/(2^{21})$

3.9. Output Effects

The TSCS42XX offers Bass enhancement, Treble enhancement, Stereo Depth enhancement. The output effects processing is outlined in the following sections.

3.9.1. FX Control Register

Table 60. FXCTL

Register Address	Bit	Label	Type	Default	Description
R57 (39h) FXCTL	7:5	RSVD	R	000	Reserved
	4	3DEN	RW	0	3D Enhancement Enable 0 = Disabled 1 = Enabled
	3	TEEN	RW	0	Treble Enhancement Enable 0 = Disabled 1 = Enabled
	2	TNLFBYP	RW	0	Treble Non-linear Function Bypass: 0 = Enabled 1 = Bypassed
	1	BEEN	RW	0	Bass Enhancement Enable 0 = Disabled 1 = Enabled
	0	BNLFBYP	RW	0	Bass Non-linear Function Bypass: 0 = Enabled 1 = Bypassed

3.10. Stereo Depth (3-D) Enhancement

The TSCS42XX has a digital depth enhancement option to artificially increase the separation between the left and right channels, by enabling the attenuation of the content common to both channels. The amount of attenuation is programmable within a range. The input is prescaled (fixed) before summation to prevent saturation.

The 3-D enhancement algorithm is a tried and true algorithm that uses two principles.

- 1 If the material common to the two channels is removed, then the speakers will sound more 3-D.
- 2 If the material for the opposite channel is presented to the current channel inverted, it will tend to cancel any material from the opposite channel on the current ear. For example, if the material from the right is presented to the left ear inverted, it will cancel some of the material from the right ear that is leaking into the right ear.

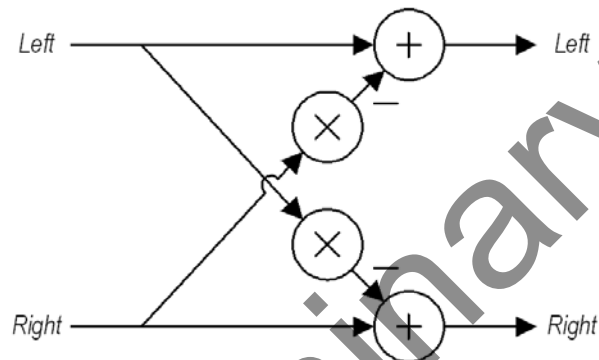

Figure 10. 3-D Channel Inversion

Note: .3D_Mix specifies the amount of the common signal that is added from the left and right channels. This number is a fractional amount between -1 and 1. For proper operation, this value is typically negative.

3.11. Psychoacoustic Bass Enhancement

One of the primary audio quality issues with small speaker systems is their inability to reproduce significant amounts of energy in the bass region (below 200Hz). While there is no magic mechanism to make a speaker reproduce frequencies that it is not capable of, there are mechanisms for fooling the ear into thinking that the bass material is being heard.

The psychoacoustic bass processor relies on a psychoacoustic principle called “missing fundamental”. If the human ear hears a proper series of harmonics for a particular bass note, the listener will hear the fundamental of that series, even if it is not present.

A processing algorithm using this principle allows for improving the apparent low frequency response of an audio system below what it is actually capable of. Below is a diagram of the implementation of this algorithm.

3.12. Treble Enhancement

One of the mechanisms used to limit the bit rate for compressed audio is to first remove high frequency information before compression. When these files are decompressed, this can lead to dull sounding audio. The IDT treble enhancement replaces these lost high frequencies.

The enhanced treble function works much like the enhanced bass, however it's intended use is different. The Enhanced treble uses a non linear function to add treble harmonics to a signal that has limited high-frequency bandwidth (such as a low bit rate MP3). In this case, the algorithm makes use of the audio fact that presence of audio between 4-8K is a good predictor of audio between 10K-20K.

TSCS42XX

Portable Consumer CODECs

The enhanced treble NLF has a different set of requirements than the psychoacoustic bass. In particular, the presence of odd high frequency harmonics is objectionable. Thus the most promising NLF for enhanced treble is a half wave rectifier.

3.13. Mute and De-Emphasis

The TSCS42XX has a Soft Mute function, which is used to gradually attenuate the digital signal volume to zero. The gain returns to its previous setting if the soft mute is removed. At startup, the codec is muted by default; to enable audio play, the mute bit must be cleared to 0.

After the equalization filters, de-emphasis may be performed on the audio data to compensate for pre-emphasis that may be included in the audio stream. De-emphasis filtering is only available for 48kHz, 44.1kHz, and 32kHz sample rates.

3.14. Mono Operation and Phase Inversion

Normal stereo operation converts left and right channel digital audio data to analog in separate DACs. However, it is also possible to have the same signal (left or right) appear on both analog output channels by disabling one channel; alternately, there is a mono-mix mode that mixes the two channels digitally before converting to analog using only one DAC. In this mode, the other DAC is switched off, and the resulting mixed stream signal can appear on both analog output channels.

The DAC output defaults to non-inverted. Setting DACPOLL and DACPOLR bits will invert the DAC output phase on the left and right channels.

3.14.1. DAC Control Register

Register Address	Bit	Label	Type	Default	Description
R24 (18h) CNVRTR1	7	DACPOLR	RW	0	Invert DAC Right signal
	6	DACPOLL	RW	0	Invert DAC Left signal
	5:4	DMONOMIX [1:0]	RW	00	DAC mono mix 00: stereo 01: mono ((L/2)+(R/2)) into DACL, '0' into DACR 10: mono ((L/2)+(R/2)) into DACR, '0' into DACL 11: mono ((L/2)+(R/2)) into DACL and DACR
	3	DACMU	RW	1	Digital Soft Mute 1 = mute 0 = no mute (signal active)
	2	DEEMP	RW	0	De-emphasis Enable 1 = Enabled 0 = Disable
	1:0	DACDITH	RW	00	DAC Dither Mode: 0 = Dynamic, half amplitude 1 = Dynamic, full amplitude 2 = DAC dither disabled 3 = Static

Table 61. CNVRTR1 Register

3.15. Speaker Outputs

3.15.1. Headphone Output

The HPOut pins can drive a 16W or 32W headphone or alternately drive a line output. The signal volume of the headphone amplifier can be independently adjusted under software control by writing to HPVOL_L and HPVOL_R. Setting the volume to 0000000 will mute the output driver; the output remains at ground, so that no click noise is produced when muting or un-muting.

Gains above 0dB run the risk of clipping large signals.

To minimize artifacts such as clicks and zipper noise, the headphone and BTL outputs feature a volume fade function that smoothly changes volume from the current value to the target value.

3.15.1.1. Headphone Volume Control Registers

Register Address	Bit	Label	Type	Default	Description
R2 (00h) HPVOLL	7	RSVD	R	0	Reserved
	6:0	HPVOL_L [6:0]	RW	1110111 (0dB)	Left Headphone Volume 1111111 = +6dB 1111110 = +5.25dB ... 1110111 = 0dB ... 0000001 = -88.5dB 0000000 = Analog mute Note: If HPVOLU is set, this setting will take effect after the next write to the Right Input Volume register.
R3 (01h) HPVOLR	7	RSVD	R	0	Reserved
	6:0	HPVOL_R [6:0]	RW	1110111	Right Headphone Volume 1111111 = +6dB 1111110 = +5.25dB ... 1110111 = 0dB ... 0000001 = -88.5dB 0000000 = Analog mute

Table 62. HPVOL L/R Registers

3.15.2. DDX™ Class D Audio Processing

For additional information on the DDX™ Class D solution, please see the application note on www.idt.com.

The DDX™ Class D PWM Controller performs the following signal processing:

- Feedback filters are applied to shape any noise. The filters move noise from audible frequencies to frequencies above the audio range.
- The PWM block converts the data streams to tri-state PWM signals and sends them to the power stages.
- Finally, the Class-D controller block adjusts the output volume to provide constant output power across supply voltage.

The power stages boost the signals to higher levels, sufficient to drive speakers at a comfortable listening level.

3.15.3. Constant Output Power Mode

In normal operation the BTL amplifier is rated at 0.5W (full scale digital with 6dB BTL gain) into an 8 ohm load at 3.6V but will vary from about 0.38W to about 1.2W across a 3.1V to 5.5V supply range. However, when constant output power mode is enabled, the full scale output is held constant from 3.1V to 5.5V.

The BTL amplifier in TSC42XX will continuously adjust to power supply changes to ensure that the full scale output power remains constant. This is not an automatic level control. Rather, this function prevents sudden volume changes when switching between battery and line power. Please note, when in this mode the amplifier efficiency may be reduced and decreases with higher supply voltages and lower target values.

A simple 5-bit ADC is used to monitor PVDD. As PVDD raises or lowers, the analog circuit will send a 5-bit code to the digital section that will average and then calculate a gain adjustment. The BTL audio signal will be multiplied by this gain value (in addition to the user volume controls).

The user will select a target value for the circuit. The constant output function will calculate a gain adjustment that will provide approximately the same full scale output voltage as provided when PVDD causes the same code value. So, if the target is 9 then a PVDD voltage of about 3.7V would generate a code value of 9 and a full scale output power of about 630mW into 8 ohms. If PVDD should rise to 4V, generating a code of 13, then the constant output power circuit would reduce the gain by 0.75dB (4 codes * 0.1875dB) to keep the full scale output at the target level.

The circuit may be configured to add gain, attenuation, or both to maintain the full-scale output level. If the needed adjustment falls outside of the range of the circuit (only attenuation is enabled and gain is needed, for example) then the circuit will apply as much correction as it is able. Through the use of gain, attenuation, and target values, different behaviors may be implemented:

- Attenuation only, target set to mimic a low supply voltage - Constant output level across battery state with constant quality (THD/SNR)
- Attenuation only, target set to mimic a moderate supply voltage - Output limiting to an approximate power level. Level will decrease at lower supply voltages but won't increase beyond a specific point.
- Gain only, target at or near max - Output will remain relatively constant but distortion will increase as PVDD is lowered. This mimics the behavior of common class-AB amplifiers.
- Gain and attenuation - Output remains at a level below the maximum possible at the highest supply voltage and above the theoretical full scale at minimum supply. Full scale PCM input clips when the supply voltage is low but won't become too loud when the supply voltage is high.

In addition to maintaining a constant output level, PVDD may be monitored for a large, sudden, change. If the High Delta function is enabled and PVDD changes more than 4 code steps since the last cycle, the output will be rapidly reduced then gradually increased to the target level.

When using this circuit, please take note of the following:

- The full scale output power may be limited by the supply voltage.
- Full scale output power is affected by other gain controls in the output path including the EQ and compressor/limiter.
- The Constant Output Power function is intended to help maintain a constant output level, not an exact output level. The output level for a specific target may vary part to part. If limiting is required for safety or other reasons, be conservative and set the target well below the maximum allowable level.
- Noise on the PVDD supply may cause erratic behavior. Use the recommended supply decoupling caps and verify that the power supply can support the peak currents demanded by a class-D amplifier.

Constant Output Power error (dB) relative to a target of 8 for an ideal part and the output error if left uncorrected across a 3.1 to 5.5V supply range.

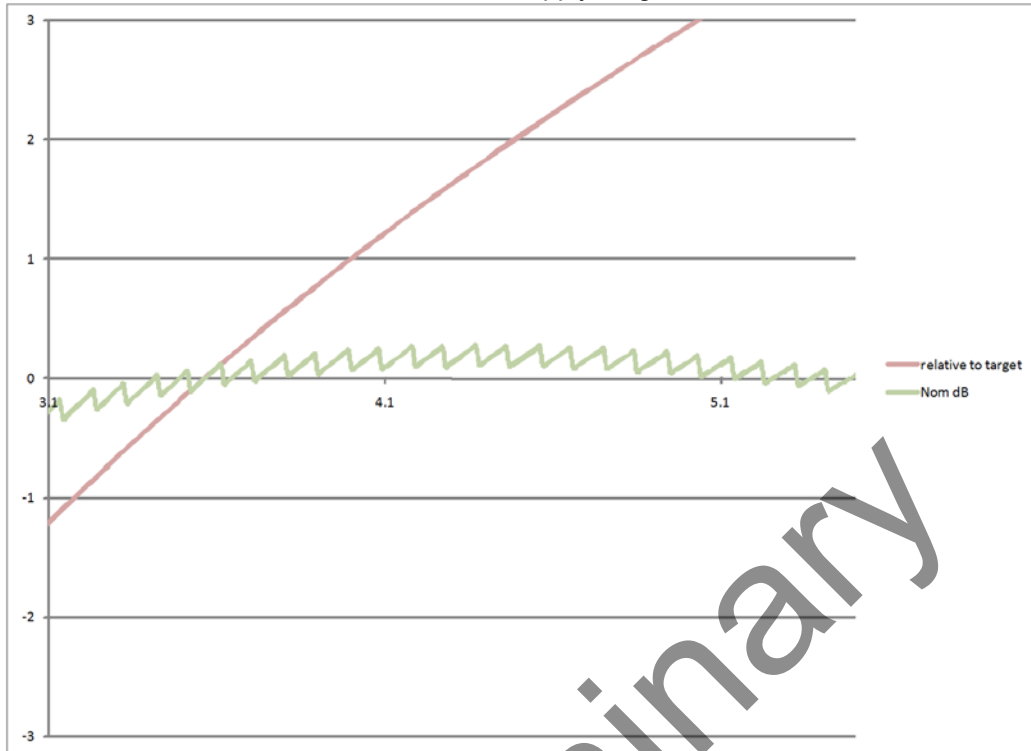

Figure 11. Constant Output Power Error

Constant Output Power for nominal and high/low reference across a 3.1 to 5.5V supply range. (Uncorrected power shown for reference) A target of 8 roughly corresponds to 0.5W at 3.6V into 8 ohms.

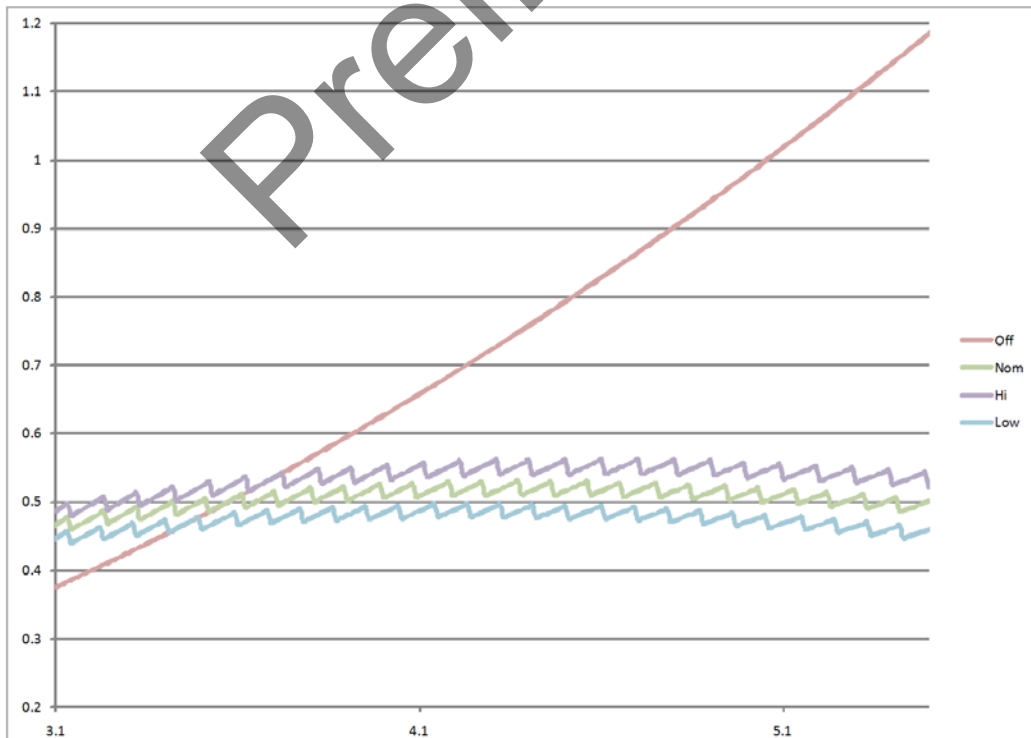

Figure 12. Constant Output Power nominal and high/low

3.15.3.1. Under Voltage Lock Out

When the PVDD supply becomes low, the BTL amplifier may be disabled to help prevent undesirable amplifier operation (overheat) or system level problems (battery under-voltage.)

The same circuit that monitors the PVDD supply to help maintain a constant output power is used to monitor the PVDD supply for a critical under-voltage situation. If the sense circuit consistently returns a 0 code then the PVDD supply is less than the minimum required for proper operation. To prevent accidental shutdown due to a noisy supply at the minimum operating range, the output of the PVDD sense circuit will be averaged for at least 200ms.

Preliminary

3.15.3.2. Registers Constant Output Power 1

Register Address	Bit	Label	Type	Default	Description
R34 (22h) Constant Output Power 1(COP1)	7	COPAtten	RW	0	1 = Constant Output Power function will use attenuate the BTL output if the PVDD sense circuit returns a code higher than the target value.
	6	COPGain	RW	0	1 = Constant Output Power function will use attenuate the BTL output if the PVDD sense circuit returns a code higher than the target value.
	5	HDeltaEn	RW	0	1 = If the PVDD code value has changed more than 4 counts since the last gain adjustment, the output will be reduced rapidly then slowly returned to the target level.
	4:0	COPTarget[4:0]	RW	8h	5-bit target for the Constant Output Power function.

Table 63. Constant Output Power 1 Register

3.15.3.3. Registers Constant Output Power 2

Register Address	Bit	Label	Type	Default	Description
R35 (23h) Constant Output Power 2(COP2)	7	RSVD	R	0	Reserved
	6	RSVD	R	0	Reserved
	5:2	AvgLength[2:0]	RW	000	Constant Output Power Average Length (number of supply detect cycles to average): 0h = 1 1h = 2 2h = 4 3h = 8 4h = 16 5h = 32 6h = 64 7h = 128 8h = 256 9h = 512 Ah-Fh = Reserved
	1:0	MonRate[2:0]	RW	100	Supply Detect Monitor Rate: 0h = 0.25ms 1h = 0.5ms 2h = 1ms 3h = 2ms

Table 64. Constant Output Power 2 Register

3.15.3.4. Registers Constant Output Power 3

Register Address	Bit	Label	Type	Default	Description
R137 (89h) Constant Output Power 3(COP3)	7	HIGHDELTA	R	0	Constant Output Power High Delta Status: 0 = No high delta event is currently being detected or recovered from 1 = A high delta event has been detected and the COP function is adjusting.
	6	UNDERVOLTAGE	R	0	Under Voltage Lockout Status: 0 = Supply is not below the UVLO threshold 1 = Supply is below the UVLO threshold.
	5:0	COPADJ	R	0h	Constant Output Power Adjustment Status (0.1875dB Steps, Twos Complement Value): 20h = -6dB 21h = -5.8125dB ... FFh = -0.1875dB 00h = 0dB 01h = +0.1875dB ... 1Fh = +5.8125dB

Table 65. Constant Output Power 3 Register

3.15.3.5. Configuration Register

Register Address	Bit	Label	Type	Default	Description
R31 (1Fh) CONFIG0	7:6	ASDM[1:0]	RW	10h	ADC Modulator Rate: 00b = Reserved 01b = Half 10b = Full 11b = Auto
	5:4	DSDM[1:0]	RW	10h	DAC Modulator Rate: 00b = Reserved 01b = Half 10b = Full 11b = Auto
	3:2	RSVD	R	0h	Reserved for future use.
	1	DC_BYPASS	RW	0	DAC DC Filter Bypass: 0 = Filter enabled 1 = Filter bypassed
	0	SD_FORCE_ON	RW	0	Supply Detect Force On: 0 = Supply detect not forced on 1 = Supply detect forced on. Note: If not forced on, the supply detect logic will automatically be enabled when features that use it are enabled (COP, UVLO)

Table 66. CONFIG0 Register

3.15.3.6. PWM Control 0 Register

Register Address	Bit	Label	Type	Default	Description
R66 (42h) PWM0	7:6	SCTO	RW	11	Class-D Short Circuit Detect Time-out 00 = 10uS 01 = 100uS 10 = 500uS 11 = 100mS
	5	UVLO	RW	1	Under Voltage Lock Out 1 = BTL output disabled if PVDD sense circuit returns code 0
	4	RESERVED	RW	1	Reserved
	3	BFCLR	RW	0	PWM Noise Shaper Clear: 0 = Filter enabled 1 = Filter disabled.
	2	PWMMODER	RW	1	PWM Modulation Type: 0 = Binary 1 = Ternary
	1	RESERVED	RW	0	Reserved
	0	NOOFFSET	RW	0	No Offset between left/right PWM frames: 0 = Frames offset 1 = Frames aligned

Table 67. PWM0 Register

3.15.3.7. PWM Control 1 Register

Register Address	Bit	Label	Type	Default	Description
R67 (43h) PWM1	7	RSVD	R	0	Reserved
	6:2	dithpos[4:0]	RW	0	Dither position, where dither inserted after NS. 0,1,2 = dither bits 2:0 4 = dither bits 3:1 5 = dither bits 4:1 19 = dither bits 19:17
	1	dith_range	RW	0	1 = dither -1 to +1, 0 = -3 to +3
	0	dithclr	RW	0	1 = disable dither

Table 68. PWM1 Register

3.15.3.8. PWM Control 2 Register

Register Address	Bit	Label	Type	Default	Description
R68 (44h) PWM2	7:2		R	0h	Reserved
	1		R	0	Reserved
	0		R	0	Reserved

Table 69. PWM2 Register

3.15.3.9. PWM Control 3 Register

Register Address	Bit	Label	Type	Default	Description
R69 (45h) PWM3	7:6	outctrl[1:0]	RW	0h	pwm output muxing 0 = normal 1 = swap 0/1 2 = ch0 on both 3 = ch1 on both
	5:3		R	0h	Reserved
	2:0	cvalue[5:0]	RW	3h	PWM C Value

Table 70. PWM3 Register

3.16. Other Output Capabilities

Each audio analog output can be separately enabled. Disabling outputs serves to reduce power consumption, and is the default state of the device.

3.16.1. Audio Output Control

See Power management section. The output enable bits are also power management bits and the outputs will be turned off when disabled.

Register Address	Bit	Label	Type	Default	Description
R27 (1Bh) Power Management (2)(PWRM2)	7	D2S	RW	0	Analog Input D2S: 0 = Power down 1 = Power up
	6	HPL	RW	0	Headphone Left Output Buffer + DAC: 0 = Power down 1 = Power u
	5	HPR	RW	0	Headphone Right Output Buffer + DAC: 0 = Power down 1 = Power up
	4	SPKL	RW	0	Speaker Left Output Buffer: 0 = Power down 1 = Power up
	3	SPKR	RW	0	Speaker Right Output Buffer: 0 = Power down 1 = Power up
	2	INSELL	RW	0	Analog Input Select Mux Left: 0 = Power down 1 = Power up
	1	INSELR	RW	0	Analog Input Select Mux Right: 0 = Power down 1 = Power up
	0	VREF	RW	1	Vref (necessary for all other functions): 0 = Power down 1 = Power up

Note: A value of "1" indicates the output is enabled; a value of '0' disables the output.

Table 71. Power Management 2 Register

3.16.2. *Speaker Enable*

The SPKR_EN pin is used to enable the speaker outputs.. Control bits determine the meaning and polarity of the input.

Preliminary

3.16.2.1. Speaker Enable Register

Register Address	Bit	Label	Type	Default	Description
R29 (1Ch) Additional Control (CTL)	7	HPSWEN	RW	0h	Headphone Switch Enable: 0 = Headphone switch disabled 1 = Headphone switch enabled
	6	HPSWPOL	RW	0h	Headphone Switch Polarity: 0 = HPDETECT high indicates headphone 1 = HPDETECT high indicates speaker
	5:4	EQ2SW	RW	0h	EQ2 behavior due to speaker/headphone output state: 00b = EQ is not disabled due to headphone/speaker logic 01b = EQ is disabled when headphone output is active 10b = EQ is disabled when speaker output is active 11b = EQ is disabled when headphone AND speaker output are active
	3:2	EQ1SW	RW	0h	EQ1 behavior due to speaker/headphone output state: 00b = EQ is not disabled due to headphone/speaker logic 01b = EQ is disabled when headphone output is active 10b = EQ is disabled when speaker output is active 11b = EQ is disabled when headphone AND speaker output are active
	1	TSDEN	RW	0h	Thermal Shutdown Enable (See section 7.9) 0: thermal shutdown disabled 1: thermal shutdown enabled
	0	TOEN	RW	0h	Zero Cross Time-out Enable 0: Time-out Disabled 1: Time-out Enabled - volumes updated if no zero cross event has occurred before time-out

Table 72. Additional Control Register

3.16.3. Speaker Operation

SWEN	SWPOL	SPKR_EN Pin state	SPKOut ¹	Speaker Enabled
0	X	X	0	no
0	X	X	1	yes
1	0	0	0	no
1	0	0	1	yes
1	0	1	X	no
1	1	0	X	no
1	1	1	0	no
1	1	1	1	yes

Table 73. Speaker Operation

1.SPKOut = Logical OR of the SPKL and SPKR enable (power state) bits

3.16.4. EQ Operation

EQnSW1	EQnSW0	EQ Behavior ¹
0	0	EQ is not disabled due to Headphone/Speaker logic
0	1	EQ is disabled when Headphone output is active
1	0	EQ is disabled when Speaker output is active
1	1	EQ is disabled when Headphone AND Speaker output are active

Table 74. EQ Operation

1.EQ must be enabled. EQ behavior is dependent on HP_DET and Output power state programming.

Preliminary

3.17. Thermal Shutdown

To avoid overpowering and overheating the codec when the amplifier outputs are driving large currents, the TSC42XX incorporates a thermal protection circuit. If enabled, and the device temperature reaches approximately 150°C, the speaker and headphone amplifier outputs will be disabled. Once the device cools, the outputs will be automatically re-enabled.

3.17.1. Algorithm description:

There are 2 trip points, “high” and “low”. High indicates a critical overheat requiring a reduction in volume to avoid damage to the part. Low is set for a slightly lower temperature point, indicating that the current level is safe but that increased volume would result in a critical overheat condition.

Normally, the overheat bits are polled every 8ms but may be polled at 4ms, 8ms, 16ms, or 32ms by adjusting the Poll value. Reductions in volume will be allowed to happen at the Poll rate. Increases in volume are programmable to happen every 1, 2, 4, or 8 Poll cycles and in steps of 0.75dB to 6dB. This allows a full scale volume increase in a range of 10s of milliseconds to 10s of seconds.

When both overheat bits are 0, the volume is allowed to increment by the IncStep size, unless the volume has already reached the maximum value allowed. Any subsequent increment will be held off until the programmed number of polling cycles have occurred.

When the low overheat bit is 1 and the high overheat bit is 0, this indicates that the volume is currently at a safe point but the temperature is higher than desired and incrementing the volume may cause severe overheating. The volume is held at the current value.

When the high overheat bit is 1, damage could occur, so the volume setting will be immediately reduced by the Decrement Step value. As the overheat bits are re-polled, this volume reduction will continue until the high overheat bit drops to 0 or the volume value reaches the minimum setting. If the high overheat bit remains 1 even at the minimum setting, then the mute control bit will be asserted. If the high overheat bit persists even after mute, then the BTL amp will be powered down.

3.17.2. Thermal Trip Points.

The high and low trip points can be adjusted to suit the needs of a particular system implementation. There is a “shift” value (TripShift) which sets the low trip point, and there is a “split” value (TripSplit) that sets how many degrees above the low trip point the high trip point is.

By default:

TripShift = 2 (140 degrees C)
TripSplit = 0 (15 degrees C)

Therefore:

High Trip Point = 155°C.
Low Trip Point = 140°C.

3.17.3. Instant Cut Mode

This mode can be used to make our algorithm react faster to reduce thermal output but will cause more pronounced volume changes. If enabled:

- Only the high overheat is used, the low overheat is ignored.
- Whenever polled, if the high overheat is 1, then the volume setting will immediately be set to 0h.
- Conversely, if the high overheat is 0, the volume setting will immediately be set to the MaxVol value.
- Both volume clear and volume set events occur at the polling rate.

During this mode, the algorithm still possesses the ability to mute and then power down the BTL amp if the high overheat continues to be 1. This mode is disabled by default.

3.17.4. Short Circuit Protection

To avoid damage to the outputs if a short circuit condition should occur, both the headphone and BTL amplifiers implement short circuit protection circuits. The headphone output amplifier will detect the load current and limit its output if in an over current state. The BTL amplifier will sense a short to PVDD, ground, or between its +/- outputs and disable its output if a short is detected. After a brief time, the amplifier will turn on again. If a short circuit condition is still present, the amplifier will disable itself again.

3.17.5. Thermal Shutdown Registers

3.17.5.1. Temp Sensor Control/Status Register

Register Address	Bit	Label	Type	Default	Description
R29 (1Dh) Temp Sensor Control/Status (THERMTS)	7	TripHighStat	R	0	Temp sensor high trip point status 0 = Normal Operation 1 = Over Temp Condition
	6	TripLowStat	R	0	Temp sensor low trip point status 0 = Normal Operation 1 = Over Temp Condition
	5:4	TripSplit[1:0]	RW	0h	Temp sensor "split" setting. Determines how many degrees above the low trip point the high trip is set: 0h = 15 Degrees C 1h = 30 Degrees C 2h = 45 Degrees C 3h = 60 Degrees C.
	3:2	TripShift[1:0]	RW	2h	Temp sensor "shift" setting. Determines the low trip temperature: 0h = 110 Degrees C 1h = 125 Degrees C 2h = 140 Degrees C 3h = 155 Degrees C.
	1:0	Poll[1:0]	RW	1h	Temp sensor polling interval 0h = 4ms 1h = 8ms 2h = 16ms 3h = 32ms

Table 75. THERMTS Register

3.17.5.2. Temp Sensor Status Register

Register Address	Bit	Label	Type	Default	Description
R30 (1Eh) Speaker Thermal Algorithm Control (THERMSPKR1)	7	ForcePwd	RW	1	Force powerdown enable for the speaker thermal algorithm: 0 = Speaker will remain powered up even if the temp sensor continues to report an overheat condition at minimum volume (mute) 1 = Speaker will be powered down if the temp sensor reports an overheat at the minimum volume (mute)
	6	InstCutMode	RW	0	Instant Cut Mode 0 = Both temp sensor status bits used to smoothly adjust the volume. 1 = Only the high temp sensor status bit will be used to set the volume. volume will be set to the full volume or mute (IncStep and DecStep are ignored.)
	5:4	IncRatio[1:0]	RW	0h	Increment interval ratio. Determines the ratio between the speaker volume increment interval and the speaker volume decrement interval (increment rate is equal to or slower than decrement rate): 0h = 1:1 1h = 2:1 2h = 4:1 3h = 8:1
	3:2	IncStep[1:0]	RW	0h	Increment step size for the speaker thermal control algorithm (occurs at the temp sensor polling rate X the increment interval ratio.) 0h = 0.75dB 1h = 1.5dB 2h = 3.0dB 3h = 6.0dB
	1:0	DecStep[1:0]	RW	1h	Decrement step size for the speaker thermal control algorithm (occurs at the temp sensor polling rate.) 0h = 3dB 1h = 6dB 2h = 12dB 3h = 24dB

Table 76. THERMTSPKR1 Register

Register Address	Bit	Label	Type	Default	Description
R136 (88h) Speaker Thermal Algorithm Status (THERMSPKR2)	7	ForcePwdStatus	R	0	0: Speaker not powered down due to thermal algorithm 1: Speaker has been powered down because overtemp condition was present even though the speaker was muted.
	6:0	VolStatus[6:0]	R	08	Current speaker volume value. If no overheat is being reported by the temperature sensor, this value should be equal to the greater of the left or right speaker volume setting.

Table 77. THERMTSPKR2 Register

4. INPUT AUDIO PROCESSING

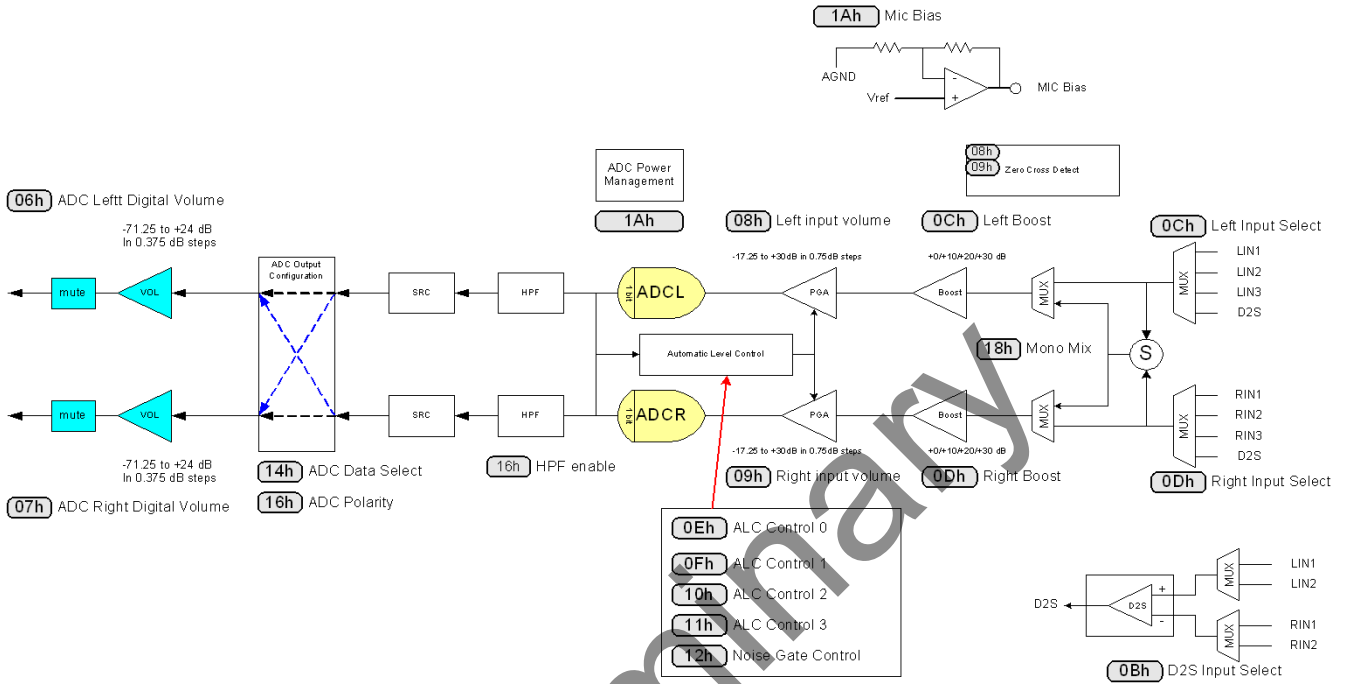

4.1. Analog Inputs

The TSCS42XX provides multiple high impedance, low capacitance AC-coupled analog inputs with an input signal path to the stereo ADCs. Prior to the ADC, there is a multiplexor that allows the system to select which input is in use. Following the mux, there is a programmable gain amplifier and also an optional microphone gain boost. The gain of the PGA can be controlled either by the system, or by the on-chip level control function. The stereo record path can also operate with the two channels mixed to mono either in the analog or digital domains.

Signal inputs are biased internally to AVSS but AC coupling capacitors are required when connecting microphones (due to the 2.5V microphone bias) or when offsets would cause unacceptable “zipper noise” or pops when changing PGA or boost gain settings. To avoid audio artifacts, the line inputs are kept biased to analog ground when they are muted or the device is placed into standby mode.

4.1.1. Input Software Control Register

Register Address	Bit	Label	Type	Default	Description
R12 (0Ch) ADC Signal Path Control Left (INSELL)	7:6	INSEL_L	RW	00	Left Channel Input Select 00 = LINPUT1 01 = LINPUT2 10 = LINPUT3 11 = D2S
	5:4	MICBST_L	RW	00	Left Channel Microphone Gain Boost 00 = Boost off (bypassed) 01 = 10dB boost 10 = 20dB boost 11 = 30dB boost
	3:0	RSVD	R	0000	Reserved
R13 (0Dh) ADC Signal Path Control Right (INSELR)	7:6	INSEL_R	RW	00	Right Channel Input Select 00 = RINPUT1 01 = RINPUT2 10 = RINPUT3 11 = D2S
	5:4	MICBST_R	RW	00	Right Channel Microphone Gain Boost 00 = Boost off (bypassed) 01 = 10dB boost 10 = 20dB boost 11 = 30dB boost
	3:0	RSVD	R	0000	Reserved

4.2. Mono Mixing and Output Configuration

The stereo ADC can operate as a stereo or mono device, or the two channels can be mixed to mono. Mixing can occur either in the input path (analog, before ADC) or after the ADC. MONOMIX determines whether to mix to mono, and where.

For analog mono mix, either the left or right channel ADC can be used for the audio stream. The other ADC may be powered off to conserve power. A differential input amplifier may be selected as a mono source to either ADC input. This D2S amplifier can select either Input 1 or Input 2 using the DS bit.

The system also has the flexibility to select the data output. ADCDSEL configures the interface, assigning the source of the left and right ADC independently.

4.2.1. ADC D2S Input Mode Register

Register Address	Bit	Label	Type	Default	Description
R11 (0Bh) ADC Input mode (INMODE)	7:1	RSVD	R	0h	Reserved
	0	DS	RW	0	Differential Input Select 0: LIN1 - RIN1 1: LIN2 - RIN2

4.2.2. ADC Mono, Filter, and Inversion

Register Address	Bit	Label	Type	Default	Description
R22 (16h) ADC Control (CNRTR0)	7	ADCPOLR	RW	0	ADC Right Channel Polarity 0 = normal 1 = inverted
	6	ADCPOLL	RW	0	ADC Left Channel Polarity 0 = normal 1 = inverted
	5:4	AMONOMIX [1:0]	RW	00	ADC mono mix 00: Stereo 01: Analog Mono Mix (using left ADC) 10: Analog Mono Mix (using right ADC) 11: Digital Mono Mix (ADCL/2 + ADCR/2 on both Left and Right ADC outputs)
	3	ADCMU	RW	1	1 = Mute ADC
	2	HPOR	RW	0	High Pass Offset Result 0 = discard offset when HPF disabled 1 = store and use last calculated offset when HPF disabled
	1	ADCHPDR	RW	0	ADC High Pass Filter Disable (Right)
	0	ADCHPDL	RW	0	ADC High Pass Filter Disable (Left)

4.2.3. ADC Data Output Configuration

Register Address	Bit	Label	Type	Default	Description
R20 (14h) Audio Interface Control 2 (AIC2)	7:6	DACDSEL[1:0]	RW	00	00: left DAC = left I2S data; right DAC = right I2S data 01: left DAC = left I2S data; right DAC = left I2S data 10: left DAC = right I2S data; right DAC = right I2S data 11: left DAC = right I2S data; right DAC = left I2S data
	5:4	ADCSEL[1:0]	RW	00	00: left I2S data = left ADC; right I2S data = right ADC 01: left I2S data = left ADC; right I2S data = left ADC 10: left I2S data = right ADC; right I2S data = right ADC 11: left I2S data = right ADC; right I2S data = left ADC
	3	TRI	RW	0	Interface Tri-state (See Section 9.2.4)
	2:0	BLRCM	RW	0	Bitclock and LRclock mode (See Section 9.2.4)

4.3. Microphone Bias

The MICBIAS output is used to bias electric type microphones. It provides a low noise reference voltage used for an external resistor biasing network. The MICB control bit is used to enable the output.

The MICBIAS can source up to 3mA of current; therefore, the external resistors must be large enough to conform to this limit.

4.3.1. Microphone Bias Control Register

Register Address	Bit	Label	Type	Default	Description
R26 (1Ah) Power Management (1)	1	MICB	RW	0	Microphone Bias Enable 0 = OFF (high impedance output) 1 = ON

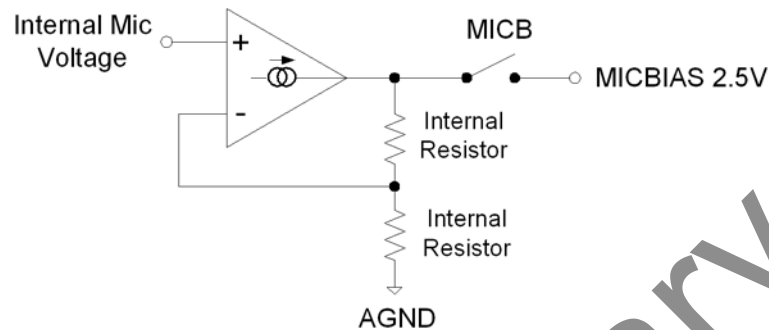

4.4. Programmable Gain Control

The Programmable Gain Amplifier (PGA) enables the input signal level to be matched to the ADC input range. Amplifier gain is adjustable across the range +30dB to -17.25dB (using 0.75dB steps). The PGA can be controlled directly by the system software using the Input Volume Control registers (INVOLL and INVOLR), or alternately the Automatic Level Control (ALC) function can automatically control the gain. If the ALC function is used, writing to the Input Volume Control registers has no effect.

Left and right input gains are independently adjustable. By controlling the update bit (INVOLU), the left and right gain settings can be simultaneously updated. To eliminate zipper noise, LZCEN and RZCEN bits enable a zero-cross detector to insure changes only occur when the signal is at zero. A time-out for zero-cross is also provided, using TOEN in register R29 (1Dh).

4.4.1. Input PGA Software Control Register

Register Address	Bit	Label	Type	Default	Description
R8 (08h) Left Input Volume (INVOLL)	7	INMUTEL	RW	0	Left Input Mute: 1 = Enable mute 0 = Disable mute Note: If INVOLU is set, this setting will take effect after the next write to the right Input Volume Register
	6	IZCL	RW	0	Left Channel Zero Cross Detector 1 = Change gain on zero cross only 0 = Change gain immediately Note: If INVOLU is set, this setting will take effect after the next write to the Right Input Volume register.
	5:0	INVOL_L [5:0]	RW	010111 (0dB)	Left Channel Input Volume Control 111111 = +30dB 111110 = +29.25dB ... 0.75dB steps down to 000000 = -17.25dB Note: If INVOLU is set, this setting will take effect after the next write to the Right Input Volume register.
R9 (09h) Right Input Volume (INVOLR)	7	RSVD	R	0	Reserved
	6	IZCR	RW	0	Right Channel Zero Cross Detector 1 = Change gain on zero cross only 0 = Change gain immediately
	5:0	INVOL_R [5:0]	RW	010111 (0dB)	Right Channel Input Volume Control 111111 = +30dB 111110 = +29.25dB ... 0.75dB steps down to 000000 = -17.25dB
R28 (1Ch) Additional Control (CTL)	0	TOEN	RW	0	Zero Cross Time-out Enable 0: Time-out Disabled 1: Time-out Enabled - volumes updated if no zero cross event has occurred before time-out

4.5. ADC Digital Filter

To provide the correct sampling frequency on the digital audio outputs, ADC filters perform true 24-bit signal processing and convert the raw multi-bit oversampled data from the ADC using the digital filter path illustrated below.

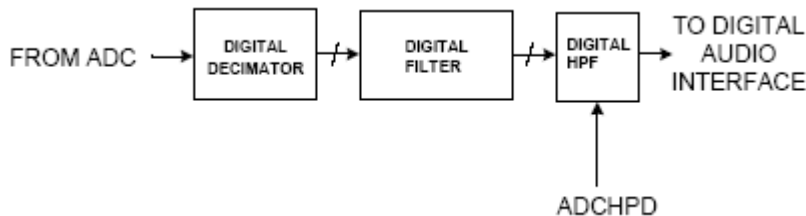

TSCS42XX

Portable Consumer CODECs

The ADC digital filters contain a software-selectable digital high pass filter. When the high-pass filter is enabled, the dc offset is continuously calculated and subtracted from the input signal. The HPOR bit enables the last calculated DC offset value to be stored when the high-pass filter is disabled; this value will then continue to be subtracted from the input signal. To provide support for calibration, the stored and subtracted value will not change unless the high-pass filter is enabled even if the DC value is changed. The high pass filter may be enabled separately for each of the left and right channels.

The output data format can be programmed by the system. This allows stereo or mono recording streams at both inputs. Software can change the polarity of the output signal.

4.5.1. ADC Signal Path Control Register

Register Address	Bit	Label	Type	Default	Description
R22 (16h) ADC Control (CNVRTR0)	7	ADCPOLR	RW	0	0 = Right polarity not inverted 1 = Right polarity inverted
	6	ADCPOLL	RW	0	0 = Left polarity not inverted 1 = Left polarity inverted
	5:4	AMONOMIX [1:0]	RW	00	ADC mono mix 00: Stereo 01: Analog Mono Mix (using left ADC) 10: Analog Mono Mix (using right ADC) 11: Digital Mono Mix
	3	ADCMU	RW	1	1 = Mute ADC
	2	HPOR	RW	0	High Pass Offset Result 0 = discard offset when HPF disabled 1 = store and use last calculated offset when HPF disabled
	1	ADCHPDR	RW	0	ADC High Pass Filter Disable (Right)
	0	ADCHPDL	RW	0	ADC High Pass Filter Disable (Right)

4.5.2. ADC High Pass Filter Enable Modes

ADCHPDR	ADCHPDL	High Pass Mode
0	0	High-pass filter enabled on left and right channels
0	1	High-pass filter disabled on left channel, enabled on right channel
1	0	High-pass filter enabled on left channel, disabled on right channel
1	1	High-pass filter disabled on left and right channels

4.6. Digital ADC Volume Control

The ADC volume can be controlled digitally, across a gain and attenuation range of -71.25dB to +24dB (0.375dB steps). The level of attenuation is specified by an eight-bit code 'ADCVOL_x', where 'x' is L, or R. The value "00000000" indicates mute; other values describe the number of 0.375dB steps above -71.25dB.

The ADCVOLU bit controls the updating of digital volume control data. When ADCVOLU is written as '0', the ADC digital volume is immediately updated with the ADCVOL_L data when the Left ADC Digital Volume register is written. When ADCVOLU is set to '1', the ADCVOL_L data is held in an internal holding register until the Right ADC Digital Volume Register is written.

4.6.1. ADC Digital Volume Control Register

Register Address	Bit	Label	Type	Default	Description
R6 (06h) Left ADC Digital Volume	7:0	ADCVOL_L [7:0]	RW	10111111 (0dB)	Left ADC Digital Volume Control 0000 0000 = Digital Mute 0000 0001 = -71.25dB 0000 0010 = -70.875dB ... 0.375dB steps up to 1111 1111 = +24dB Note: If ADCVOLUME is set, this setting will take effect after the next write to the Right Input Volume register.
R7 (07h) Right ADC Digital Volume	7:0	ADCVOL_R [7:0]	RW	10111111 (0dB)	Right ADC Digital Volume Control 0000 0000 = Digital Mute 0000 0001 = -71.25dB 0000 0010 = -70.875dB ... 0.375dB steps up to 1111 1111 = +24dB

4.7. Automatic Level Control (ALC)

The TSCS42XX has an automatic level control to achieve constant recording volume across a range of input signal levels. The device uses a digital peak detector to monitor and adjusts the PGA gain to provide a constant signal level at the ADC input. A range of adjustment between -6dB and -28.5dB (relative to ADC full scale) can be selected. The device provides programmable attack, hold, and decay times to smooth adjustments. The level control also features a peak limiter to prevent clipping when the ADC input exceeds a threshold. Note that if the ALC is enabled, the input volume controls are ignored.

4.7.1. ALC Operation

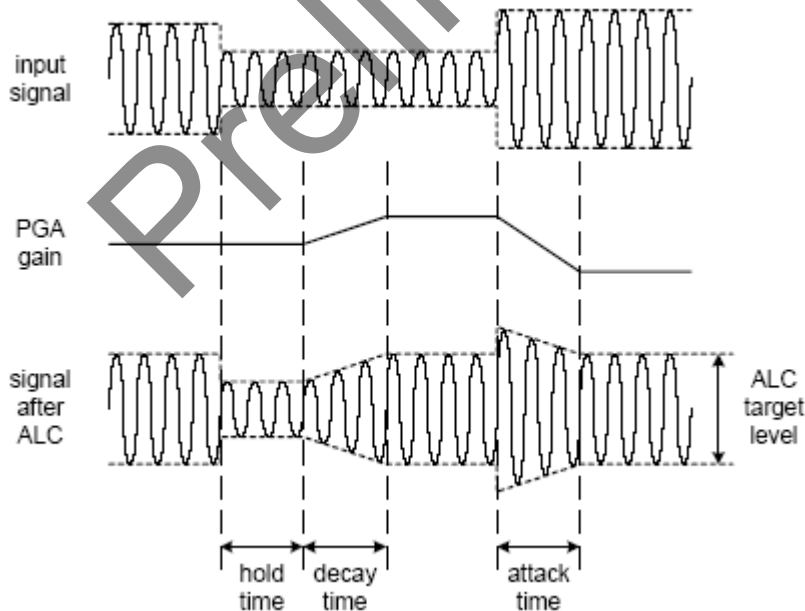

When ALC is enabled, the recording volume target can be programmed between -6dB and -28.5dB (relative to ADC full scale). The ALC will attempt to keep the ADC input level to within +/-0.5dB of the target level. An upper limit for the PGA gain can also be imposed, using the MAXGAIN control bits.

TSCS42XX

Portable Consumer CODECs

Hold time specifies the delay between detecting a peak level being below target, and the PGA gain beginning to ramp up. It is specified as $2^n \times 2.67\text{mS}$, enabling a range between 0mS and over 40s.; ramp-down begins immediately if the signal level is above the target.

Decay (Gain Ramp-Up) Time is the time that it takes for the PGA to ramp up across 90% of its range. The time is $2^n \times 24\text{mS}$. The time required for the recording level to return to its target value therefore depends on the decay time and on the gain adjustment required.

Attack (Gain Ramp-Down) Time is the time that it takes for the PGA to ramp down across 90% of its range. Time is specified as $2^n \times 24\text{mS}$. The time required for the recording level to return to its target value depends on both the attack time and on the gain adjustment required.

When operating in stereo, the peak detector takes the maximum of left and right channel peak values, and both PGAs use the same gain setting, to preserve the stereo image. If the ALC function is only enabled on one channel, only one PGA is controlled by the ALC mechanism, and the other channel runs independently using the PGA gain set through the control registers.

If one ADC channel is unused, the peak detector will ignore that channel.

The ALC function can operate when the two ADC outputs are mixed to mono in the digital domain or in the analog domain.

Preliminary

4.7.2. ALC Control Register

Register Address	Bit	Label	Type	Default	Description
R14 (0Eh) ALC Control 0	7:3	RSVD	R	00000	Reserved
	2	ALC MODE	RW	0	0: ALC Mode 1: Limiter mode
	1:0	ALCSEL [1:0]	RW	00 (OFF)	ALC function select 00 = ALC off (PGA gain set by register) 01 = Right channel only 10 = Left channel only 11 = Stereo (PGA registers unused) Note: ensure that LINVOL and RINVOL settings (reg. 0 and 1) are the same before entering this mode.
R15 (0Fh) ALC Control 1	7	RSVD	R	0	Reserved
	6:4	MAXGAIN [2:0]	RW	111 (+30dB)	Set Maximum Gain of PGA 111: +30dB 110: +24dB ...(-6dB steps) 001: -6dB 000: -12dB
	3:0	ALCL [3:0]	RW	1011 (-12dB)	ALC target – sets signal level at ADC input 0000 = -28.5dB fs 0001 = -27.0dB fs ... (1.5dB steps) 1110 = -7.5dB fs 1111 = -6dB fs
R16 (10h) ALC Control 2	7	RSVD	R	0	Reserved
	6:4	MINGAIN	RW	000	Sets the minimum gain of the PGA 000 = -17.25db 001 = -11.25 ... 110 = +18.75dB 111 = +24.75db where each value represents a 6dB step.
	3:0	HLD [3:0]	RW	0000 (0ms)	ALC hold time before gain is increased. 0000 = 0ms 0001 = 2.67ms 0010 = 5.33ms ... (time doubles with every step) 1111 = 43.691s
R17 (11h) ALC Control 3	7:4	DCY [3:0]	RW	0011 (192ms)	ALC decay (gain ramp-up) time 0000 = 24ms 0001 = 48ms 0010 = 96ms ... (time doubles with every step) 1010 or higher = 24.58s
	3:0	ATK [3:0]	RW	0010 (24ms)	ALC attack (gain ramp-down) time 0000 = 6ms 0001 = 12ms 0010 = 24ms ... (time doubles with every step) 1010 or higher = 6.14s

4.7.3. Peak Limiter

To prevent clipping, the ALC circuit also includes a limiter function. If the ADC input signal exceeds 87.5% of full scale (-1.16dB), the PGA gain is ramped down at the maximum attack rate, until the signal level falls below 87.5% of full scale. This function is automatically enabled whenever the ALC is enabled.

4.7.4. Input Threshold

To avoid hissing during quiet periods, the TSC42XX has an input threshold noise gate function that compares the signal level at the inputs to a noise gate threshold. Below the threshold, the programmable gain can be held, or the ADC output can be muted. The threshold can be adjusted in increments of 1.5dB.

The noise gate activates when the signal-level at the input pin is less than the Noise Gate Threshold (NGTH) setting.

The ADC output can be muted. Alternatively, the PGA gain can be held.

The threshold is adjusted in 1.5dB steps. The noise gate only works in conjunction with the ALC, and always operates on the same channel(s) as the ALC.

4.7.5. Noise Gate Control Register

Register Address	Bit	Label	Type	Default	Description
R12 (12h) Noise Gate Control (NGATE)	7:3	NGTH [4:0]	RW	00000	Noise gate threshold (compared to ADC full-scale range) 00000 -76.5dBfs 00001 -75dBfs ... 1.5 dB steps 11110 -31.5dBfs 11111 -30dBfs
	2:1	NGG [1:0]	RW	00	Noise gate type X0 = PGA gain held constant 01 = mute ADC output 11 = reserved (do not use this setting)
	0	NGAT	RW	0	Noise gate function enable 1 = enable 0 = disable

4.8. Digital Microphone Support

Line Input 3 may be an analog line (mic) or digital microphone input depending on the part option.

The digital microphone interface permits connection of a digital microphone(s) to the CODEC via the DMIC_DAT, and DMIC_CLK 2-pin interface. DMIC_DAT is an input that carries individual channels of digital microphone data to the ADC. In the event that a single microphone is used, the data is ported to both ADC channels. This mode is selected using a control bit and the left time slot is copied to the ADC left and right inputs.

The DMIC_CLK output is synchronous to the internal master (DSP) clock and is adjustable in 4 steps. Each step provides a clock that is a multiple of the chosen ADC base rate and modulator rate. The default frequency is 320/3 times the ADC base rate for 32KHz, and 80 times the base rate for 44.1KHz and 48KHz base rates.

4.8.1. DMIC Clock

SDM Rate	DMRate [1:0]	Base Rate	DSPCLK	DMIC_CLK divisor	DMIC_CLK
Full	00	32 KHz	40.960 MHz	12	3.413333 MHz
		44.1 KHz	56.448 MHz	16	3.528 MHz
		48 KHz	61.440 MHz	16	3.84 MHz
	01	32 KHz	40.960 MHz	16	2.56 Mhz
		44.1 KHz	56.448 MHz	20	2.8224 MHz
		48 KHz	61.440 MHz	20	3.072 MHz
	10	32 KHz	40.960 MHz	20	2.048 Mhz
		44.1 KHz	56.448 MHz	24	2.352 MHz
		48 KHz	61.440 MHz	24	2.56 MHz
	11	32 KHz	40.960 MHz	24	1.706667 Mhz
		44.1 KHz	56.448 MHz	32	1.764 MHz
		48 KHz	61.440 MHz	32	1.92 MHz
Half	00	32 KHz	40.960 MHz	16	2.56 MHz
		44.1 KHz	56.448 MHz	16	3.528 MHz
		48 KHz	61.440 MHz	16	3.84 MHz
	01	32 KHz	40.960 MHz	24	1.706667 MHz
		44.1 KHz	56.448 MHz	24	2.352 MHz
		48 KHz	61.440 MHz	24	2.56 MHz
	10	32 KHz	40.960 MHz	32	1.28 MHz
		44.1 KHz	56.448 MHz	32	1.764 MHz
		48 KHz	61.440 MHz	32	1.92 MHz
	11	32 KHz	40.960 MHz	40	1.024 MHz
		44.1 KHz	56.448 MHz	40	1.4112 MHz
		48 KHz	61.440 MHz	40	1.536 MHz

The two DMIC data inputs are shown connected to the ADCs through the same multiplexors as the analog ports. Although the internal implementation is different between the analog ports and the digital microphones, the functionality is the same. In most cases, the default values for the DMIC clock rate and data sample phase will be appropriate and an audio driver will be able to configure and use the digital microphones exactly like an analog microphone.

To conserve power, the analog portion of the ADC will be turned off if the D-mic input is selected. When switching from the digital microphone to an analog input to the ADC, the analog portion of the ADC will be brought back to a full power state and allowed to stabilize before switching from the digital microphone to the analog input. This should take less than 10mS.

If the ADC path is powered down, the DMIC_CLK output will be driven low to place the DMIC element into a low power state. (Many digital microphones will enter a low power state if the clock input is held at a DC level or toggled at a slow rate.)

TSCS42XX
Portable Consumer CODECs

The TSC42XX codec supports the following digital microphone configurations:

Table 8.1 Valid Digital Mic Configurations

Digital Mics	Data Sample	Notes
0	N/A	No Digital Microphones
1	Single Edge	When using a microphone that supports multiplexed operation (2-mics can share a common data line), configure the microphone for "Left" and select mono operation. "Left" D-mic data is used for ADC left and right channels.
2	Double Edge	External logic required to support sampling on a single Digital Mic pin channel on rising edge and second Digital Mic right channel on falling edge of DMIC_CLK for those digital microphones that don't support alternative clock edge (multiplexed output) capability.

Figure 8.1 Single Digital Microphone (data is ported to both left and right channels)

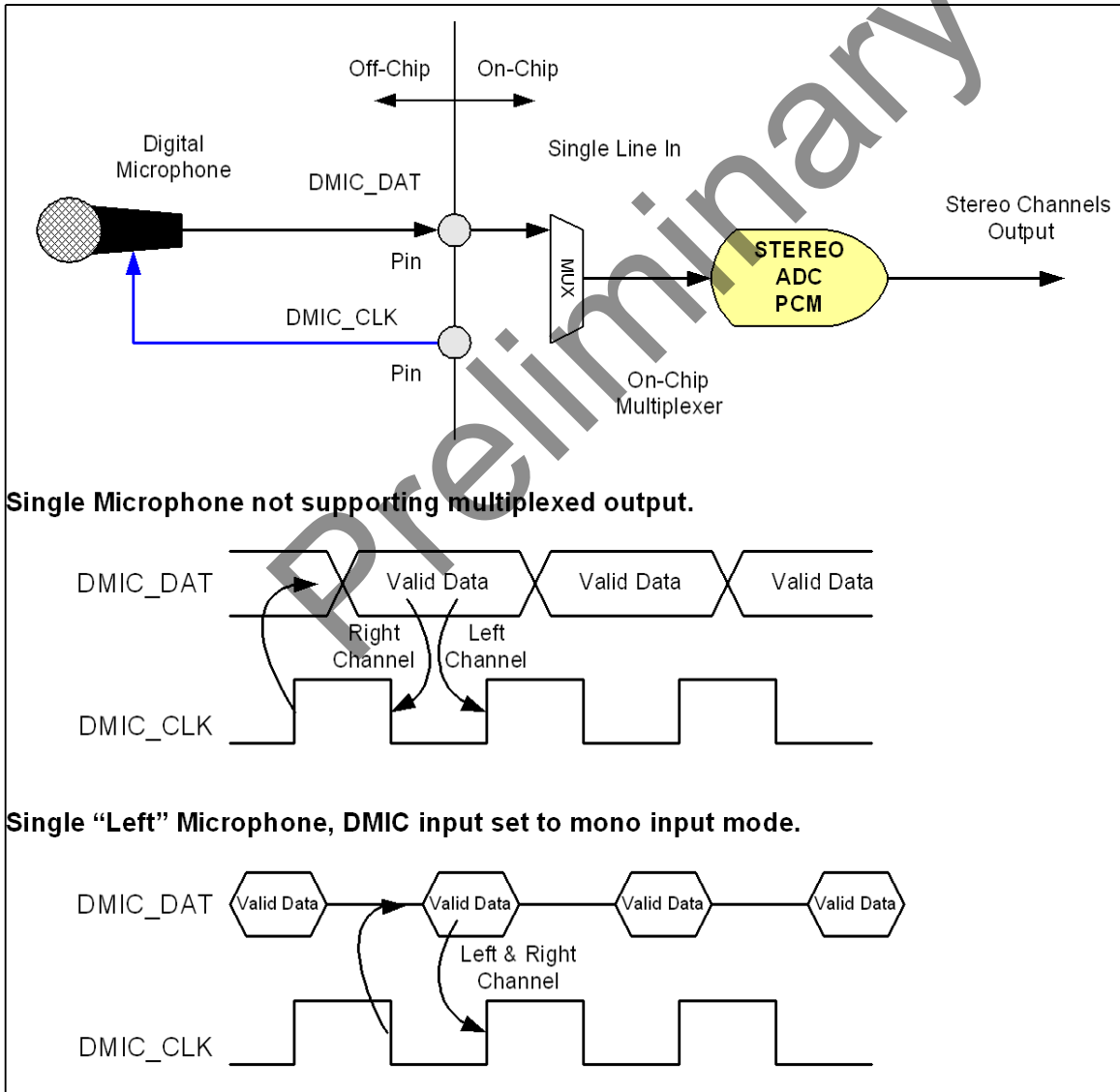
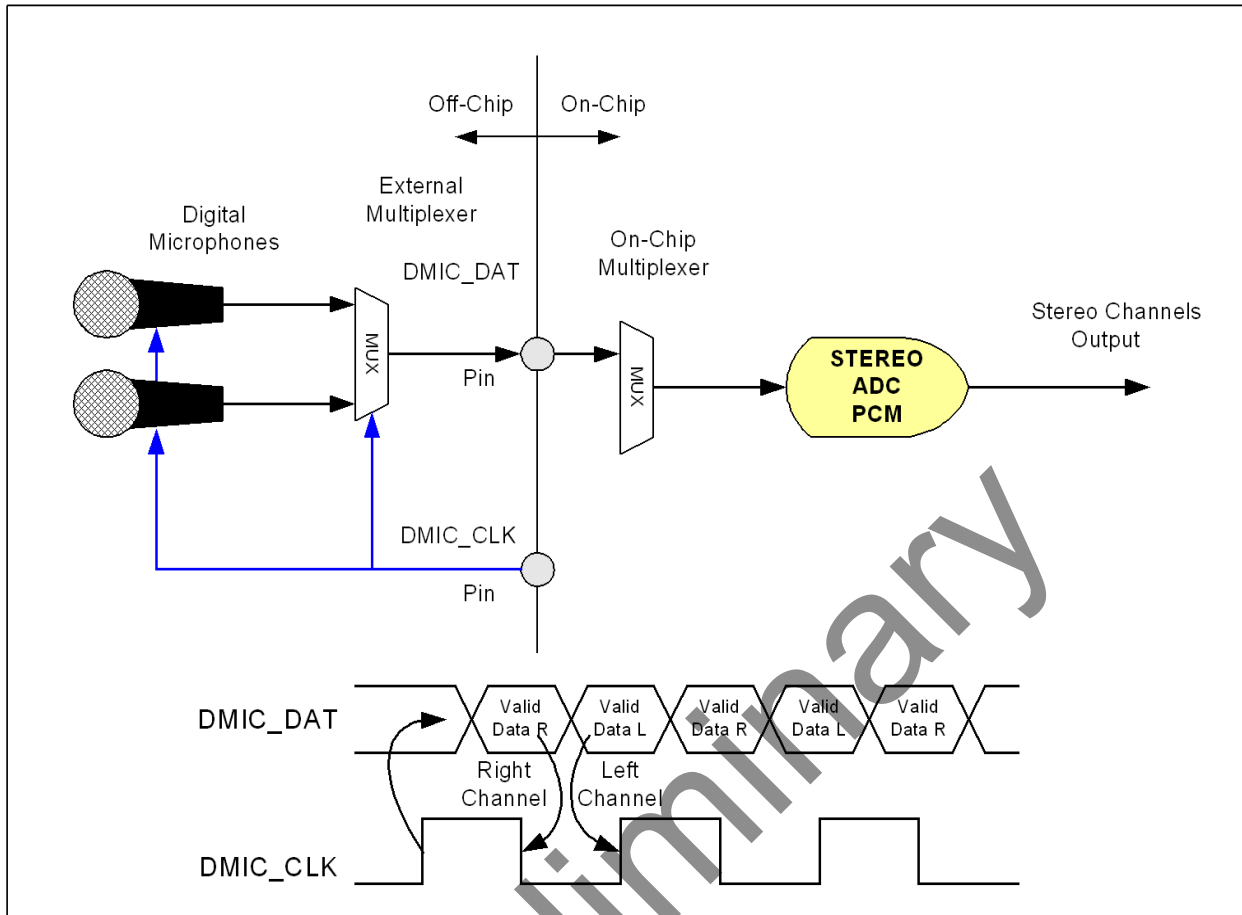

Figure 8.2 Stereo Digital Microphone Configuration



Note Some Digital Microphone Implementations support data on either edge, therefore, the external mux may not be required.

4.8.2. Digital Mic Control Register

Register Address	Bit	Label	Type	Default	Description
R36 (24h) D-Mic Control (DMICCTL)	7	DMicEn	RW	0	Digital Microphone Enable 0 = DMIC interface is disabled (DMIC_CLK low, DMIC muted) 1 = DMIC interface is enabled
	6:5	RSVD	R	00	Reserved
	4	DMono	RW	0	0 = stereo operation, 1 = mono operation (left channel duplicated on right)
	3:2	DMPAdj[1:0]	RW	00	Selects when the D-Mic data is latched relative to the DMIC_CLK. 00 = Left data rising edge / right data falling edge 01 = Left data center of high / right data center of low 10 = Left data falling edge / right data rising edge 11 = Left data center of low / right data center of high
	1:0	DMRate[1:0]	RW	00	Selects the DMIC clock rate: See table in text

5. DIGITAL AUDIO AND CONTROL INTERFACES

5.1. Data Interface

For digital audio data, the TSC42XX uses five pins to input and output digital audio data.

- ADCDOUT: ADC data output
- ADCLRCK: ADC data alignment clock
- ADCBCLK: Bit clock, for synchronization
- DACDIN: DAC data input
- DACLRCK: DAC data alignment clock
- DACBCLK: Bit clock, for synchronization

The clock signals ADCBCLK, ADCLRCK, DACBCLK, and DACLRCK are outputs when the TSC42XX operates as a master; they are inputs when it is a slave. four different data formats are supported:

- Left justified
- Right justified
- I²S
- PCM Bluetooth

All of these modes are MSB first.

5.2. Master and Slave Mode Operation

The TSC42XX can be used as either a master or slave device, selected by the MS Bit. When operating as a master, the TSC42XX generates ADCBCLK, ADCLRCLK, DACBCLK and DACLRCLK and controls sequencing of the data transfer the data pins. In slave mode, the TSC42XX provides data aligned to clocks it receives.

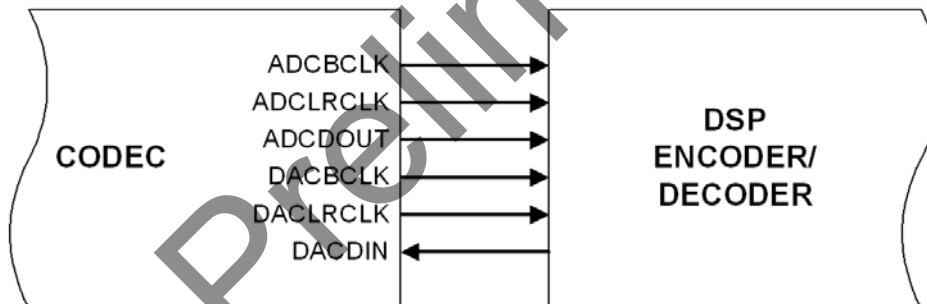

Figure 9. Master mode

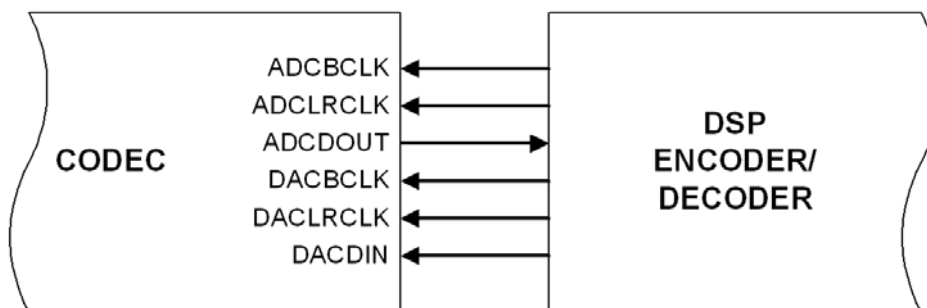

Figure 10. Slave mode

6. AUDIO DATA FORMATS

The TSC42XX supports 4 common audio interface formats and programmable clocking that provides broad compatibility with DSPs, Consumer Audio and Video SOCs, FPGAs, handset chipsets, and many other products.

In all modes, depending on word length, BCLK frequency and sample rate, there may be unused BCLK cycles before each LRCLK transition. If the converter word length is smaller than the number of clocks per sample in the frame then the DAC will ignore (truncate) the extra bits while the ADC will zero pad the output data. If the converter word length chosen is larger than the number of clocks available per sample in the frame, the ADC data will be truncated to fit the frame and the DAC data will be zero padded.

6.1. PCM Interfaces

- For digital audio data, the TSCS42XX uses four pins for each I2S/PCM audio interface.
- SDOUT1: I2S/TDM data output
- LRCLK1: I2S/TDM data alignment clock
- BCLK1: I2S1/TDM1 Bit clock, for synchronization
- SDIN1: I2S/PCM1 data input

	I2S AUDIO INTERFACES	
	INPUT	OUTPUT
I2S Port	I2S Port 1	
INPUT/OUTPUT Pins	SDIN1	SDOUT1
Master/Slave	Master/Slave	Master/Slave

Different data formats are supported as below:

- I2S
 - Left justified
 - Right justified
- TDM
- PCM
 - Linear

All of these modes are MSB first.

6.1.1. PCM(I2S) Audio Input Interface Mapping

The PCM Inputs are connected to the functional blocks as follows:

I2S Audio Input	Functional Blocks
SDIN1	I2S Input Port1

6.1.2. PCM(I2S) Audio Output Interface Mapping

Audio Data Source	I2S Output
Input Processor	SDOUT1

6.1.3. PCM control Register

	Bit	Label	Read/Write	Reset Value	Description
R195(C3h) ADPCMCTL1	7:5	GAINCODE	RW	0	PCM gain code to be sent
	4	GAINENABLE	RW	0	PCM gain code enable-if 1, replace lsb bits of data if 0, normal mode
	3	BDELAYO	RW	0	output Bit clock delay, 0 = data not delayed, 1 = data delayed.
	2	PCMFL	RW	0	PCM Frame Length in master mode, 0 = 128 bits per frame, 1 = 256 bits per frame
	1	SLSYNC	RW	0	short-Long Frame Sync, 0 = one clock wide, 1 = one slot wide
	0		R	0	Reserved

Table 9. PCM Control Register

	Bit	Label	Read/Write	Reset Value	Description
R196(C4h) ADPCMCTL2	7	RSVD	R	0	Reserved
	6	PCMMOMP	RW	0	PCM mono output mode, 0- When number of slots = 1, select left data for slot0, 1-select left data for slot0 = 1, select right data for slot0.
	5	PCMSOP	RW	0	Number of Active Slots per PCM Output Frame, 0 = one, 1 = two
	4:3	PCMDSSP	RW	0	PCM Data Slots Size, 00 = 16 bit, 01 =24 bit, 10 = 32 bit, 11=Reserved
	2		R	0	Reserved
	1		R	0	Reserved
	0		R	0	Reserved

Table 10. PCM Control Register

6.1.4. PCM control register input

	Bit	Label	Read/ Write	Reset Value	Description
R197(C5h) DACPCMCTL1	7:5		R	0	Reserved
	4		R	0	Reserved
	3	BDELAY1	RW	0	Input Bit clock delay, 0 = data not delayed, 1 = data delayed.
	2	PCMFL	RW	0	PCM Frame Length in master mode, 0 = 128 bits peer frame, 1 = 256 bits per frame
	1	SLSYNC	RW	0	short-Long Frame Sync, 0 = one clock wide, 1 = one slot wide
	0		R	0	Reserved

Table 11. PCM Control Register

	Bit	Label	Read/ Write	Reset Value	Description
R198(C6h) DACPCMCTL2	7	PCMFORMAT	RW	0	DAC input path set to PCM format if 1
	6	PCMMIM	RW	0	PCM mono input mode, 0- When number of slots = 1, select left data for slot0, 1-select left data for slot0 = 1, select right data for slot0.
	5	PCMSI	RW	0	Number of Active Slots per PCM Output Frame, 0 = one, 1 = two
	4:3	PCMDSS	RW	0	PCM Data Slots Size, 00 = 16 bit, 01 =24 bit, 10 = 32 bit, 11=Reserved
	2	PCMSIGNEXT	RW	0	Data is received in 13bit sign extended mode, left shift by 3 and pad with 0s
	1	PCM13MODE	RW	0	Data is received with un-used gain bits, set these to 0
	0		R	0	Reserved

Table 12. PCM Control Register

6.2. Left Justified Audio Interface

In Left Justified mode, the MSB is available on the first rising edge of BCLK following a LRCLK transition. The other bits are then transmitted in order. The LRCLK signal is high when left channel data is present and low when right channel data is present.

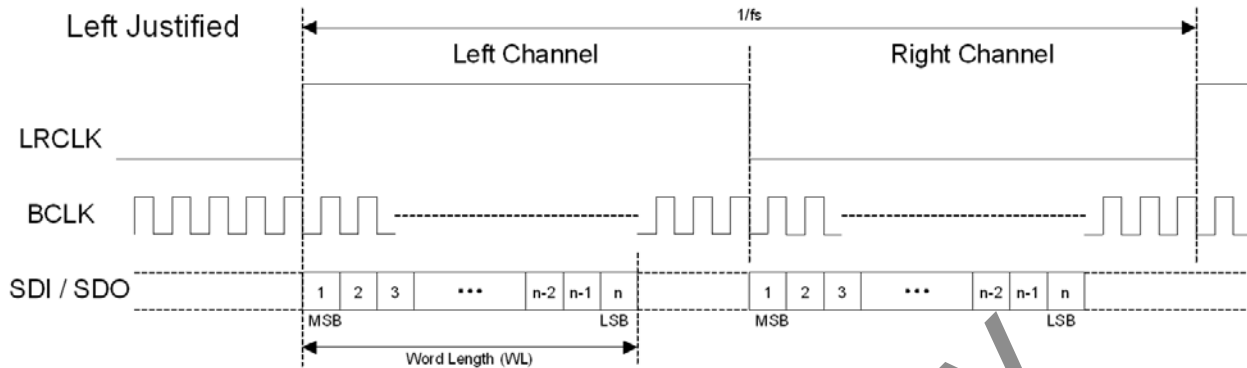

Figure 11. Left Justified Audio Interface (assuming n-bit word length)

6.3. Right Justified Audio Interface (assuming n-bit word length)

In Right Justified mode, the LSB is available on the last rising edge of BCLK before a LRCLK transition. All other bits are transmitted in order. The LRCLK signal is high when left channel data is present and low when right channel data is present.

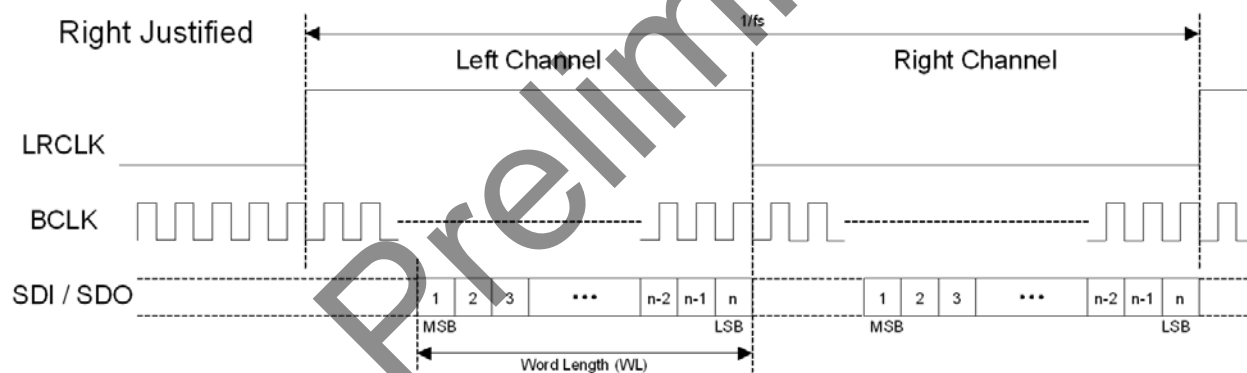

Figure 12. Right Justified Audio Interface (assuming n-bit word length)

6.4. I²S Format Audio Interface

In I²S mode, the MSB is available on the second rising edge of BCLK following a LRCLK transition. The other bits up to the LSB are then transmitted in order.

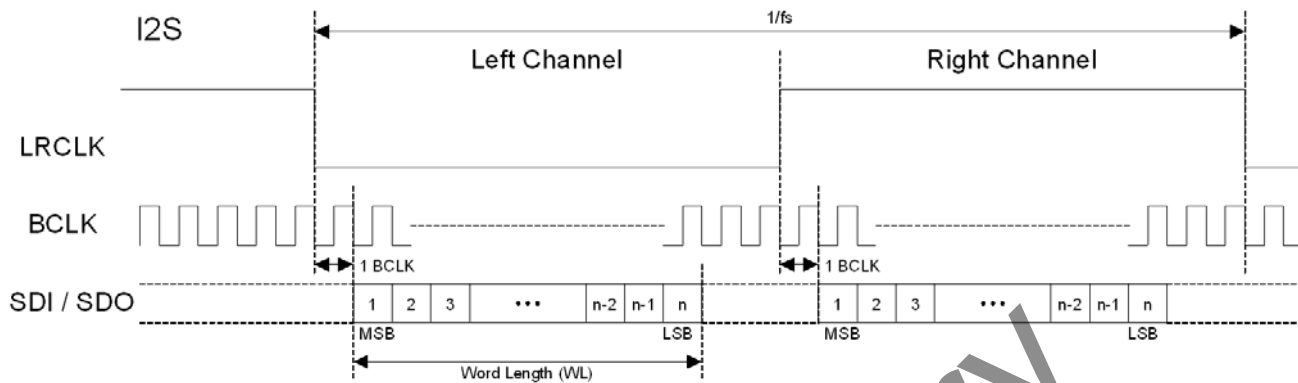

Figure 13. I²S Justified Audio Interface (assuming n-bit word length)

6.4.1. I²S Data Interface Registers

The register bits controlling audio format, word length and master / slave mode are shown below. In Master mode BCLK1, LRCLK1, are outputs; in slave mode, they are inputs.

The I²S interface can be operated in either Master or Slave mode.

6.4.2. LRCLK and BCLK Mode Control

The TSCS42XX includes a PCM audio interfaces. The clocking of data through the PCM interface is controlled by Frame Sync (LRCLK) and Bit Clock (BCLK) signals.

6.4.3. Audio Interface Output Tri-state

TRI is used to tri-state the ADCDOUT, ADCLRCK, DACLRCK, ADCBCLK, and DACBCLK pins. In Slave mode (MASTER=0) only ADCDOUT will be tri-stated since the other pins are configured as inputs. The Tri-stated pins are pulled low with an internal pull-down resistor unless that resistor is disabled.

Register Address	Bit	Label	Type	Default	Description
R20 (14h) Audio Interface Control 2 (AIC2)	7:6	DACDSEL[1:0]	RW	00	00: left DAC = left I2S data; right DAC = right I2S data 01: left DAC = left I2S data; right DAC = left I2S data 10: left DAC = right I2S data; right DAC = right I2S data 11: left DAC = right I2S data; right DAC = left I2S data
	5:4	ADCSEL[1:0]	RW	00	00: left I2S data = left ADC; right I2S data = right ADC 01: left I2S data = left ADC; right I2S data = left ADC 10: left I2S data = right ADC; right I2S data = right ADC 11: left I2S data = right ADC; right I2S data = left ADC
	3	TRI	RW	0	Tri-states ADCDOUT, ADCLRCLK, DACLRCLK, ADCBCLK, and DACBCLK pins. 0 = ADCDOUT is an output, ADCLRCLK, DACLRCLK, ADCBCLK, and DACBCLK are inputs (slave mode) or outputs (master mode) 1 = ADCDOUT, ADCLRCLK, DACLRCLK, ADCBCLK, and DACBCLK are high impedance
	2:0	BLRCM[2:0]	RW	000	Bitclock and LRclock mode. See Table Below

Table 13. AIC2 Register

6.4.4. Audio Interface Bit Clock and LR Clock configuration

Although the DAC and ADC interfaces implement separate Bit Clock and LR Clock pins, it is also possible to share one or both of the clocks.

the following restrictions must be observed when the BCLK from one path (DAC or ADC) is combined with the LRCLK from the other path (ADC or DAC) as described by the Bit Clock and LR Clock Mode Selection table below:

1. Both the DAC and ADC must be programmed for the same sample rate
2. Both the DAC and ADC must be programmed for the same number of clocks per frame
3. When in slave mode, the DAC and ADC data must be aligned relative to the provided BCLK and LRCLK (this is guaranteed in master mode)
4. The DAC and ADC must be powered down when changing the BLRCM mode
5. If sharing the BCLK from one path (DAC or ADC) and the LRCLK from the other path (ADC or DAC), shut down both the DAC and ADC before programming the sample rate and clocks per frame for either. (Again, both must match.)

6.4.5. Bit Clock and LR Clock Mode Selection

MS	BLRCM [2:0]	MODE ¹	DAC BCLK	ADC BCLK	DAC LRCLK	ADC LRCLK
0	000	Independent	Input for playback path	input for record path	Input for playback path	input for record path
0	001	Independent	Input for playback path	input for record path	Input for playback path	input for record path
0	010	Shared BCLK (DAC)	Input for playback and record	unused	Input for playback path	input for record path
0	011	Shared BCLK & LRCLK (DAC)	Input for playback and record	unused	Input for playback and record	unused
Table 14. Bit Clock and LR Clock Mode Selection						
0	100	Shared BCLK (DAC) & LRCLK (ADC)	Input for playback and record	unused	unused	Input for playback and record
0	101	Shared BCLK (ADC)	unused	Input for playback and record	Input for playback path	input for record path
0	110	Shared BCLK (ADC) & LRCLK (DAC)	unused	Input for playback and record	Input for playback and record	unused
0	111	Shared BCLK & LRCLK (ADC)	unused	Input for playback and record	unused	Input for playback and record
1	000	Independent (off if converter off)	Output for playback path (off when DACs off) ²	Output for record path (Off when ADC off) ³	Output for playback path (off when DACs off)	Output for record path (off when ADCs off)
1	001	Independent (off if all converters off)	Output for playback path (off when DACs and ADCs off)	Output for record path (off when DACs and ADCs off)	Output for playback path (off when DACs and ADCs off)	Output for record path (off when DACs and ADCs off)
1	010	Shared BCLK (DAC)	Output for playback and record (stays on if either DAC or ADC on)	unused (off)	Output for playback path (Off if DAC is off)	Output for record path (off when ADCs off)
1	011	Shared BCLK & LRCLK (DAC)	Output for playback and record (stays on if either DAC or ADC on)	unused (off)	Output for playback and record (stays on if either DAC or ADC on)	unused (off)
1	100	Shared BCLK(DAC)& LRCLK(ADC)	Output for playback and record (stays on if either DAC or ADC on)	unused (off)	unused (off)	Output for playback and record (stays on if either DAC or ADC on)
1	101	Shared BCLK (ADC)	unused (off)	Output for playback and record (stays on if either DAC or ADC on)	Output for playback path (Off if DAC is off)	Output for record path (off when ADCs off)
1	110	Shared BCLK(ADC)& LRCLK(DAC)	unused (off)	Output for playback and record (stays on if either DAC or ADC on)	Output for playback and record (stays on if either DAC or ADC on)	unused (off)
1	111	Shared BCLK & LRCLK(ADC)	unused (off)	Output for playback and record (stays on if either DAC or ADC on)	unused (off)	Output for playback and record (stays on if either DAC or ADC on)

1. When sharing both the BCLK and LRCLK between the DAC and ADC interfaces, both the DAC and ADC must be programmed for the same rate, the same number of clocks per frame, and data must be aligned the same with respect to LRCLK. Disable all converters before changing modes.

2. DAC (playback path) is off when HPL, HPR, SPKL, and SPKR power states are off.

3. ADC is off when ADCL, and ADCR power states are off (PGA, D2S, Boost power states are not considered.)

6.4.6. ADC Output Pin State

Tri-state (TRI)	Record Path Power State	ADC Data Out Pull-down (ADOPDD)	ADC Data Out State
0	Off	0	Off, pulled-low
	Off	1	Off, floating
	On	NA	Active
1	NA	0	Off, pulled-low
	NA	1	Off, floating

Table 15. ADC Data Output pin state

6.4.7. Audio Interface Control 3 Register

Register Address	Bit	Label	Type	Default	Description
R21 (15h) Audio Interface Control 3 (AIC3)	7:6	RSVD	R	0	Reserved
	5	ADOPDD	RW	0	ADCDOOUT Pull-Down Disable 0 = Pull-Down active when tri-stated or the ADC path is powered down. 1 = Pull-Down always disabled
	4	ALRPDD	RW	0	ADCLRCLK Pull-Down Disable 0 = Pull-Down active when configured as input 1 = Pull-Down always disabled
	3	ABCPDD	RW	0	ADCCLK Pull-Down Disable 0 = Pull-Down active when configured as input 1 = Pull-Down always disabled
	2	DDIPDD	RW	0	DACDIN Pull-Down Disable 0 = Pull-Down active 1 = Pull-Down always disabled
	1	DLRPDD	RW	0	DACLCLK Pull-Down Disable 0 = Pull-Down active when configured as input 1 = Pull-Down always disabled
	0	DBCPDD	RW	0	DACCLK Pull-Down Disable 0 = Pull-Down active when configured as input 1 = Pull-Down always disabled

Table 16. AIC3 Register

6.5. Bit Clock Mode

The default master mode bit clock generator automatically produces a bit clock frequency based on the sample rate and word length. When enabled by setting the appropriate BCM bits, the bit clock mode (BCM) function overrides the default master mode bit clock generator to produce the bit clock frequency shown below: Note that selecting a word length of 24-bits in Auto mode generates 64 clocks per frame (64fs)

Register Address	Bit	Label	Type	Default	Description
R23/R25 (17h/19h) ADC/DAC Sample Rate Control	7:6	ABCM[1:0] DBCM[1:0]	RW	00	BCLK Frequency 00 = Auto 01 = 32 x fs 10 = 40 x fs 11 = 64 x fs

Table 17. Master Mode BCLK Frequency Control Register

The BCM mode bit clock generator produces 16, 20, or 32 bit cycles per sample.

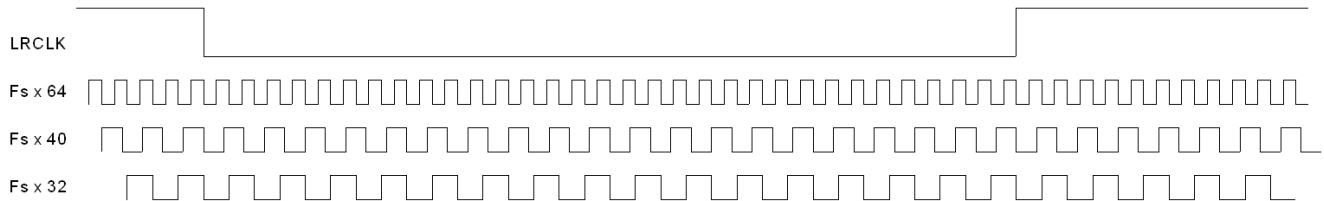

Figure 14. Bit Clock mode

Note: The clock cycles are evenly distributed throughout the frame (true multiple of LRCLK not a gated clock.)

6.6. I2C /Control Interface

The registers are accessed through a serial control interface using a multi-word protocol comprised of 8-bit words. The first 8 bits provide the device address and Read/Write flag. In a write cycle, the next 8 bits provide the register address, all subsequent words contain the data, corresponding to the 8 bits in each control register. The control interface operates using a standard 2-wire interface, as a slave device only. The TSC42XX has 8 bit device address E2 for Analog mic version of the part and D2 for Digital mic version of the part.

6.6.1. Register Write Cycle

The controller indicates the start of data transfer with a high to low transition on SDA while SCL remains high, signalling that a device address and data will follow. All devices on the 2-wire bus respond to the start condition and shift in the next eight bits on SDIN (7-bit address + Read/Write bit, MSB first). If the device address received matches the address of the TSC42XX and the R/W bit is '0', indicating a write, then the TSC42XX responds by pulling SDA low on the next clock pulse (ACK); otherwise, the TSC42XX returns to the idle condition to wait for a new start condition and valid address.

Once the TSC42XX has acknowledged a correct device address, the controller sends the TSC42XX register address. The TSC42XX acknowledges the register address by pulling SDA low for one clock pulse (ACK). The controller then sends a byte of data (B7 to B0), and the TSC42XX acknowledges again by pulling SDA low.

When there is a low to high transition on SDA while SCL is high, the transfer is complete. After receiving a complete address and data sequence the TSC42XX returns to the idle state. If a start or stop condition is detected out of sequence, the device returns to the idle condition.

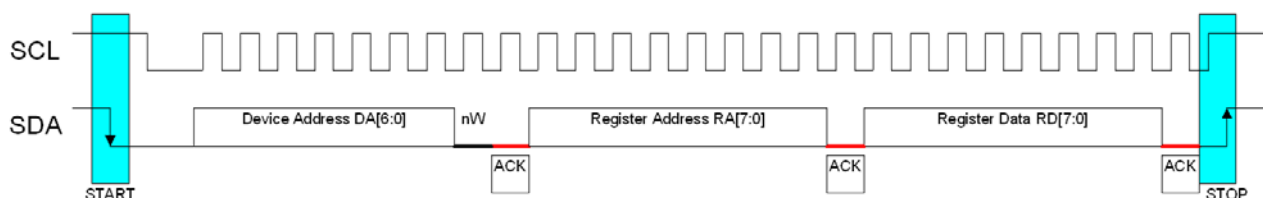

Figure 15. 2-Wire Serial Control Interface

6.6.2. Multiple Write Cycle

The controller may write more than one register within a single write cycle. To write additional registers, the controller will not generate a stop or start (repeated start) command after receiving the acknowledge for the second byte of information (register address and data). Instead the controller will continue to send bytes of data. After each byte of data is received, the register address is incremented.

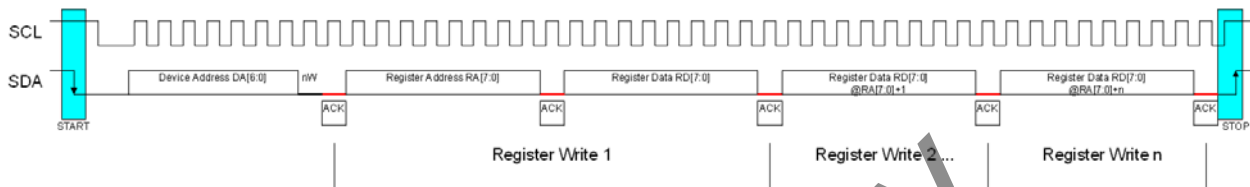

Figure 16. Multiple Write Cycle

6.6.3. Register Read Cycle

The controller indicates the start of data transfer with a high to low transition on SDA while SCL remains high, signalling that a device address and data will follow. If the device address received matches the address of the TSC42XX and the R/W bit is '0', indicating a write, then the TSC42XX responds by pulling SDA low on the next clock pulse (ACK); otherwise, the TSC42XX returns to the idle condition to wait for a new start condition and valid address.

Once the TSC42XX has acknowledged a correct address, the controller sends a restart command (high to low transition on SDA while SCL remains high). The controller then re-sends the devices address with the R/W bit set to '1' to indicate a read cycle. The TSC42XX acknowledges by pulling SDA low for one clock pulse. The controller then receives a byte of register data (B7 to B0).

For a single byte transfer, the host controller will not acknowledge (high on data line) the data byte and generate a low to high transition on SDA while SCL is high, completing the transfer. If a start or stop condition is detected out of sequence, the device returns to the idle condition.

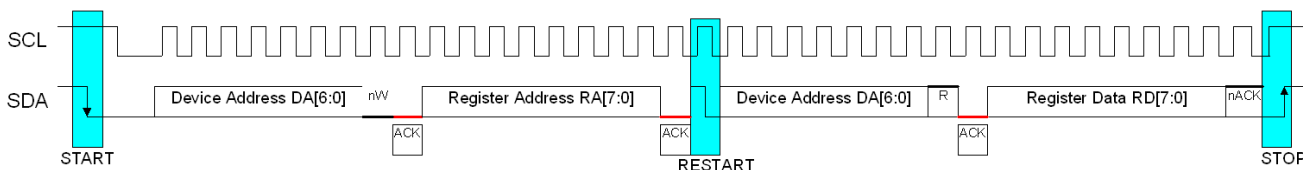

Figure 17. Read Cycle

6.6.4. Multiple Read Cycle

The controller may read more than one register within a single read cycle. To read additional registers, the controller will not generate a stop or start (repeated start) command after sending the acknowledge for the byte of data. Instead the controller will continue to provide clocks and acknowledge after each byte of received data. The codec will automatically increment the internal register address after each register has had its data successfully read (ACK from host) but will not increment the register address if the data is not received correctly by the host (nACK from host) or if the bus cycle is terminated unexpectedly (however the EQ/Filter address will be incremented even if the register address is not incremented when performing EQ/Filter RAM reads). By automatically incrementing the internal register address after each byte is read, all the internal registers of the codec may be read in a single read cycle.



Figure 18. Multiple Read Cycle

6.6.5. Device Addressing and Identification

The TSC42XX has a default slave address of D2. However, it is sometimes necessary to use a different address. The TSC42XX has a device address register for this purpose. The part itself has an 8-bit Identification register and an 8-bit revision register that provide device specific information for software. In addition, an 8-bit programmable subsystem ID register can allow firmware to provide a descriptive code to higher level software such as an operating system driver or application software.

6.6.6. Device Address Register

Register Address	Bit	Label	Type	Default	Description
R124 (7Ch) DEVADR	7:1	ADDR[7:1]	RW	1101001	7-bit slave address
	0	RSVD	R	1110001	7-bit slave address Dmic 7-bit slave address Amic.

Table 18. DEVADRI Register

6.6.7. Device Identification Registers

Register Address	Bit	Label	Type	Default	Description
R126 (7Eh) DEVIDH	7:0	DID[15:8]	R	xxh	16-bit device identification number. Contact TSI.
R125 (7Dh) DEVIDL	7:0	DID[7:0]	R	xxh	

Table 19. DEVID H&L Registers

6.6.8. Device Revision Register

Register Address	Bit	Label	Type	Default	Description
R127 (7Fh)	7:4	MAJ[3:0]	R	xh	4-bit major revision number. Contact TSI.
REVID	3:0	MNR[3:0]	R	xh	4-bit minor revision number. Contact TSI.

Table 20. REVID Register

6.6.9. Register Reset

The TSC42XX registers may be reset to their default values using the reset register. Writing a special, non-zero value to this register causes all other registers to assume their default states. Device status bits will not necessarily change their values depending on the state of the device.

Register Address	Bit	Label	Type	Default	Description
R128 (80h)	7:0	Reset[7:0]	RW	00h	Reset register Writing a value of 85h will cause registers to assume their default values. Reading this register returns 00h

Table 21. RESET Register

6.7. GPIO's

Four GPIO's are available on the GPIO1-GPIO0 pins. These GPIO pins are accessed via register bits. The general-purpose input/output (GPIO) pins can be used as either inputs or outputs. These pins are readable and can be set or read through the control interface. These pins are useful for interfacing to external hardware.

6.7.1. GPIO Usage Summary

GPIO Pin	Function 1	Function 2	Pull-Up Pull-Down
GPIO0	GPIO0 Register Bit	RSVD	Pull-Up
GPIO1	GPIO1 Register Bit	RSVD	Pull-Up

Table 22. GPIO Pin Usage Summary

6.7.2. GPIO Control Registers

6.7.2.1. GPIO Control 1 Register

Register Address	Bit	Label	Type	Default	Description
Reg 192 (C0h) GPIOCTL1	7	RESERVED	R	0	Reserved
	6	RESERVED	R	0	Reserved
	5	GPIO1CFG	RW	0	GPIO1 Configuration 0 = GPIO1 Configured as Input/Output 1 = GPIO1 Configured as Interrupt
	4	GPIO0CFG	RW	0	GPIO0 Configuration 0 = GPIO0 Configured as Input/Output 1 = GPIO0 Configured as Interrupt
	3	RESERVED	R	0	Reserved
	2	RESERVED	R	0	Reserved
	1	GPIO1DIR	RW	0	GPIO1 Input/Output 0 = GPIO1 configured as input 1 = GPIO1 configured as output
	0	GPIO0DIR	RW	0	GPIO0 Input/Output 0 = GPIO0 configured as input 1 = GPIO0 configured as output

Table 23. GPIO Control Register

6.7.2.2. GPIO Control 2 Register

Register Address	Bit	Label	Type	Default	Description
Reg 193 (C1h) GPIOCTL2	7:2	RESERVED	R	0	Reserved
	1	GPIO1PU	R	0	GPIO1 Pull up 0 = GPIO1 pull up enabled 1 = GPIO1 pull up disabled
	0	GPIO0PU	R	0	GPIO0 Pull up 0 = GPIO0 pull up enabled 1 = GPIO0 pull up disabled

Table 24. GPIO Control Register

7. CLOCK GENERATION

The TSCS42XX uses two PLL's to generate two high frequency reference clocks. The clock frequencies of each reference clock are based on multiples of 44.1KHz and 48KHz sample rates. The clock source for the PLL's can be the XTAL input, MCLK1 input via the XTAL_IN pin, the MCLK2 pin, or one of the I2S interface BCLK inputs. Each PLL can be independently powered down if the audio sample rates generated by that particular PLL are not required.

7.1. On-Chip PLLs

The TSCS42XX generates two high-quality, high-frequency clocks 122.880MHz and 112.896MHz. The PLL's support a wide range of input clock frequencies. Some typical frequencies are 19.2Mhz, 22MHz, 22.5792MHz, 24MHz, 24.576 MHz, 27MHz, and 36MHz. It should be noted that some input clock frequencies may not result in being able to generate the 122.880MHz and 112.896Mhz clocks exactly resulting in an error in the audio sample rate.

Audio Clocks - Each PLL generates one of two clock frequencies based on two audio sample rates.

122.880 MHz (2560 x 48 KHz)

112.896 MHz (2560 x 44.1 KHz)

It is important that the crystal oscillator and needed PLLs remain on until all audio functions, including jack detection, are disabled.

For supporting System Master Clock (MCLK OUT) generates a 22.5792MHz, 24.576MHz, or the PLL2 output may be selected to be output on the MCLK2 pin. This low jitter high frequency clock also can be used to drive external audio sources. The MCLK2 output frequency is limited to 50MHz. The MCLK2 pin can also be configured to input a high frequency clock from an external oscillator or other external clock source.

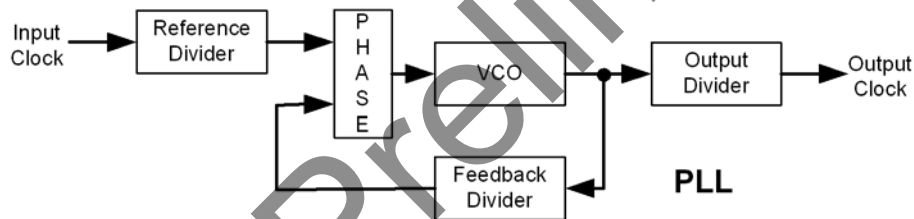

Figure 19. System Clock Diagram

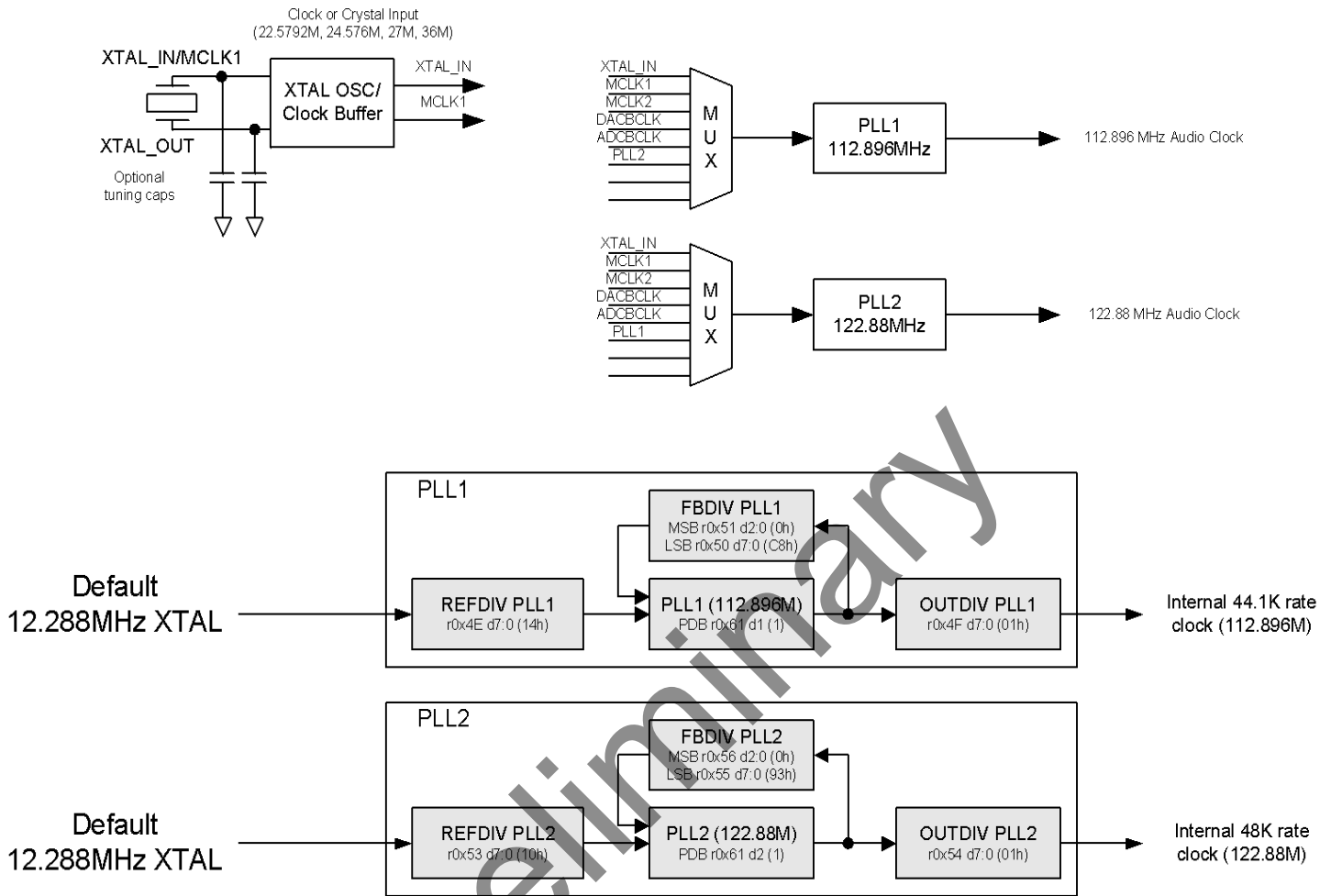

Figure 20. Clock Generation Diagram

7.2. System Clock Generation

The TSC42XX supports an internal clock and audio sample rate that is selectable between 11.025KHz, 12 KHz, 22.050KHz, 24KHz, 44.1KHz, 48KHz, 88.2KHz, and 96KHz. One bi-directional stereo I2S interfaces is available. In Master mode an internal timing generator is used to specify the audio sample rate. The sample rate specified in Master mode is independent from the internal clock rate and the specified range is 8KHz to 96KHz. A variety of sample rates based on 44.1K, 48K and 32K are supported. A highly programmable PLL enables just about any input frequency to be used.

7.2.1 PLL Dividers

The chosen input frequency is multiplied up by the PLL's to generate the required output frequencies; 122.88MHz and 112.896MHz. It should be noted that it may not always be possible to generate the required output frequencies with zero error. Some values for the PLL dividers relative a specific input frequency are shown in the table below.

TSCS42XX

Portable Consumer CODECs

Input Frequency (MHz)	Output Frequency									
	PLL1 - 122.88MHz					PLL2 - 112.896MHz				
	Reference Divider	Feedback Divider	Output Divider	Freq Error ppm	VCO (MHz) Freq	Reference Divider	Feedback Divider	Output Divider	Freq Error ppm	VCO Freq (MHz)
1.4112	N/A	N/A	N/A	N/A	N/A	4	960	3	0	338.688
1.536	2	480	3	0	368.64	2	441	3	0	338.688
2.8224	N/A	N/A	N/A	N/A	N/A	3	360	3	0	338.688
3.072	7	840	3	0	368.64	7	1029	4	0	451.584
5.6448	N/A	N/A	N/A	N/A	N/A	14	840	3	0	338.688
6.144	5	300	3	0	368.64	8	441	3	0	338.688
12	25	768	3	0	368.64	25	1176	5	0	564.48
19.2	20	384	3	0	368.64	25	441	3	0	338.688
22	55	1536	5	0	614.4	38	585	3	-11.887	338.684
22.5792	49	800	3	0	368.64	29	435	3	0	338.688
24	25	384	3	0	368.64	25	588	5	0	564.48
24.576	29	435	3	0	368.64	24	441	4	0	451.584
25	55	811	3	-9.864	368.64	42	569	3	7.3111	338.688
27	45	1024	5	0	614.4	125	1568	3	0	338.688 PD= 210Khz
36	25	256	2	0	368.64	125	1176	3	0	338.688 PD= 280Khz

Table 25. Typical PLL Divider Values

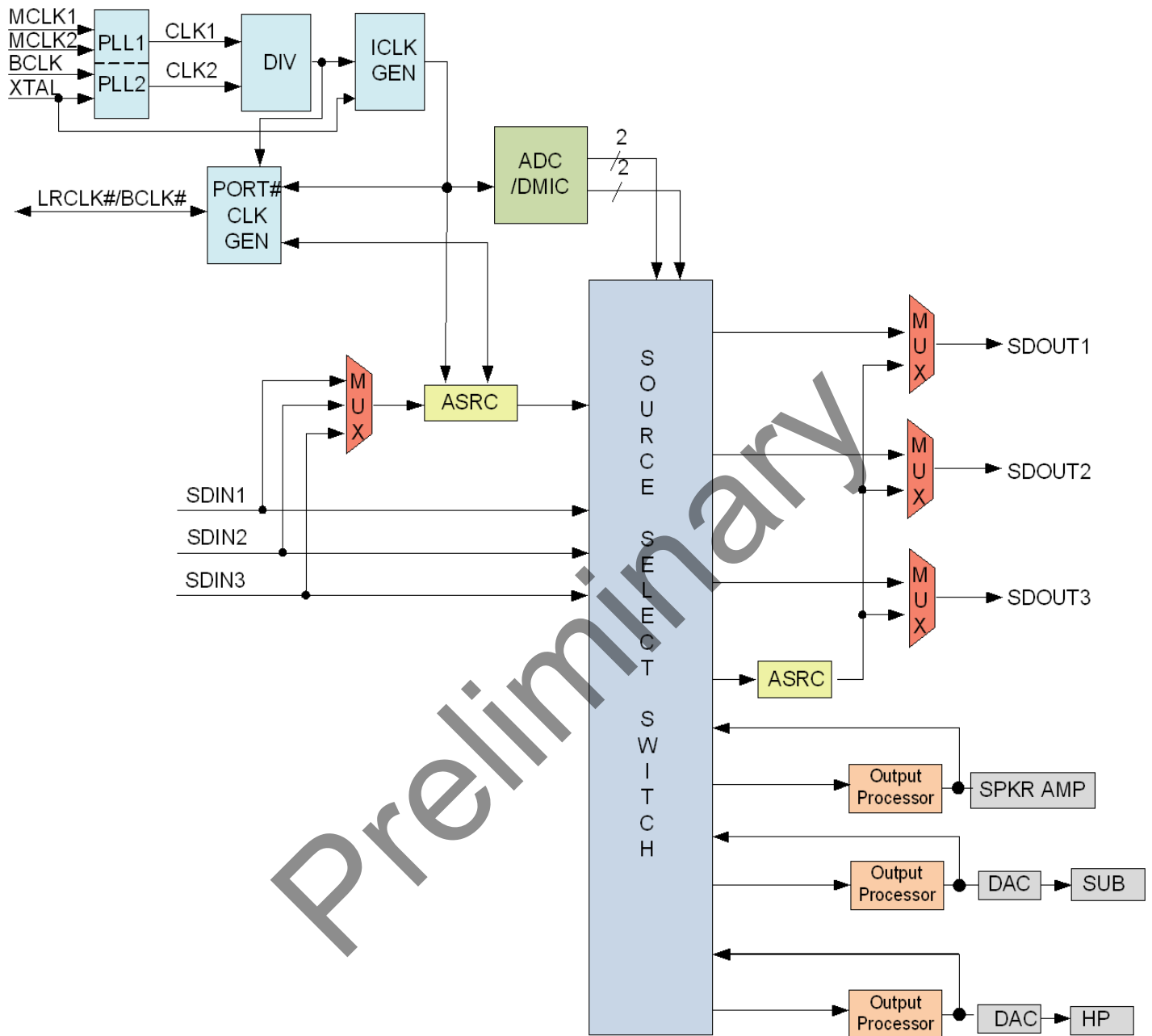

Figure 21. Simplified System Clock Block Diagram

7.2.1.1. PLLCTL0 - PLL Status Register

Register Address	Bit	Label	Type	Default	Description
R142(8Eh)	7:2	RSVD	R	00h	Reserved
	1	PLL2LK	R	0h	1 = PLL2 has obtained lock
	0	PLL1LK	R	0h	1 = PLL1 has obtained lock

Table 26. PLL Status Register

7.2.1.2. PLLREFSEL - PLL Reference Register

Register Address	Bit	Label	Type	Default	Description
R143(8Fh)	7	RSVD	R	0h	Reserved
	6:41	PLL2_REF_SEL	RW	0h	PLL2 Reference Mux, 000 = xtal_in/mclk1; 001 = mclk2; 010 = dac_bclk; 011 = adc_bclk; 100 = pll1 output; 101 - 111 = reserved
	3	RSVD	R	0h	Reserved
	2:0	PLL1_REF_SEL	RW	0h	PLL1 Reference Mux, 000 = xtal_in/mclk1; 001 = mclk2; 010 = dac_bclk; 011 = adc_bclk; 100 = pll2 output; 101 - 111 = reserved

Table 27. PLL Status Register

7.2.1.3. PLLCTL1B (122.88MHz) - PLL1 Control Register

Register Address	Bit	Label	Type	Default	Description
R96(60h)	7:6	RSVD	R	0h	Reserved
	5:4	VCOI_PLL2	RW	1h	PLL2 VCO/ICO current setting
	3:2	VCOI_PLL1	RW	1h	PLL1 VCO/ICO current setting
	1:0	RSVD	R	0h	Reserved

Table 28. PLL1 Control Register

7.2.1.4. PLLCTL9 (122.88MHz) - PLL1 Reference Clock Divider Register

Register Address	Bit	Label	Type	Default	Description
R78(4Eh)	7:0	REFDIV_PLL1	RW	19h	PLL1 refclk divider

Table 29. PLL1 Reference Clock Divider Register

7.2.1.5. PLLCTLA (122.88MHz) - PLL1 Output Divider Register

Register Address	Bit	Label	Type	Default	Description
R79(4Fh)	7:0	OUTDIV_PLL1	RW	03h	PLL1 output divider

Table 30. PLL1 Output Divider Register

7.2.1.6. PLLCTLB (122.88MHz) - PLL1 Feedback Divider Low Register

Register Address	Bit	Label	Type	Default	Description
R80(50h)	7:0	FBDIVL_PLL1	RW	80h	PLL1 feedback divider

Table 31. PLL1 Feedback Divider Low Register

7.2.1.7.PLLCTL0 (122.88MHz) - PLL1 Feedback Divider High Register

Register Address	Bit	Label	Type	Default	Description
R81(51h)	7:3	RSVD	R	0	Reserved
	2:0	FBDIVH_PLL1	RW	1h	PLL1 feedback divider

Table 32. PLL1 Feedback Divider High Register

7.2.1.8.PLLCTL12 (112.896MHz) - PLL2 Control Register

Register Address	Bit	Label	Type	Default	Description
R87(57h)	7:6		R	0	Reserved
	5:3	RZ_PLL2	RW	3h	PLL2 Zero R setting
	2:0	CP_PLL2	RW	2h	PLL2 main charge pump current setting

Table 33. PLL2 Control Register

7.2.1.9.PLLCTL1 (112.896MHz) - PLL2 Reference Clock Divider Register

Register Address	Bit	Label	Type	Default	Description
R83(53h)	7:0	REFDIV_PLL2	RW	12h	PLL2 reference clock divider

Table 34. PLL2 Reference Clock Divider Register

7.2.1.10.PLLCTL5 (112.896MHz) - PLL2 Output Divider Register

Register Address	Bit	Label	Type	Default	Description
R84(54h)	7:0	OUTDIV_PLL2	RW	03h	PLL2 output divider

Table 35. PLL2 Output Divider Register

7.2.1.11.PLLCTL10 (112.896MHz) - PLL2 Feedback Divider Low Register

Register Address	Bit	Label	Type	Default	Description
R85(55h)	7:0	FBDIVL_PLL2	RW	1ch	PLL2 feedback low divider

Table 36. PLL2 Feedback Divider Low Register

7.2.1.12.PLLCTL11 (112.896MHz) - PLL2 Feedback Divider High Register

Register Address	Bit	Label	Type	Default	Description
R86(56h)	7:3	RSVD	R	0	Reserved
	2:0	FBDIVH_PLL2	RW	2h	PLL2 feedback high divider

Table 37. PLL2 Feedback Divider High Register

7.2.1.13.PLLCTL1C - PLL Control Register

Register Address	Bit	Label	Type	Default	Description
R(61h)	7:3	RESERVED	R	0h	Reserved
	2	PDB_PLL2	RW	0h	PLL2 Power Down: 1 = Power Up 0 = Power Down
	1	PDB_PLL1	RW	0h	PLL1 Power down 1 = Power Up 0 = Power Down
	0	RESERVED	R	0h	Reserved

Table 38. PLL Control Register**7.2.2 PLL Power Down Control**

Each PLL can be powered down to save power if only one set of base audio rates is required. The base audio rates are defined as 44.1KHz based rates or 48KHz based rates. If support for either 44.1KHz or 48KHz based rates is not needed then the PLL associated with the unused rate can be powered down.

7.2.3 Audio Clock Generation

Figure 21 shows the simplified block diagram. The TSCS42XX utilizes internal PLLs to generate the PLL clocks at 112.896 MHz (22.5792MHz *5) and 122.880 MHz (24.576 *5). Intermediate clocks (61.44MHz, 40.96MHz, 56.448MHz) are then generated which are then used to generate the audio sample rates. There is one internal clock rate that can be specified to operate at 11.025KHz, 12 KHz, 22.050KHz, 24KHz, 44.1KHz, 48KHz, 88.2KHz, and 96KHz. When changing sample rates a delay of up to 5mS may be needed for the part to properly lock PLLs, flush filters, etc.

7.2.3.1.PLL Clock Source

The clock source for the PLL's can be selected from the XTAL input, MCLK1 input via the XTAL_IN pin, the MCLK2 pin or one of the I2S BCLK inputs via a selectable mux.

7.2.3.2. Internal Sample Rate Control Register

TSCS42XX

Portable Consumer CODECs

This register defines the internal sample rate.

Register Address	Bit	Label	Default	Description
R23(17h) ADCSR	7:6	ABCM	0h	ADC bit Clock Mode (for ADCBCLK generation in master mode): 0h=Auto 1h = 32x Fs 2h = 40x Fs 3h = 64x Fs
	5	RSVD	0h	Reserved
	4:3	ABR	2h	ADC Base Rate 0h = 32kHz 1h = 44.1kHz 2h = 48kHz 3h = Reserved
	2:0	ABM	2h	ADC Base Rate Multiplier 0h = 0.25x 1h = 0.5x 2h = 1x 3h = 2x 4h-7h = Reserved

Table 39. Internal Sample Rate Control Register

Register Address	Bit	Label	Default	Description
R25 (19h) DACSR	7:6	DBCM	0h	DAC bit Clock Mode (for ADCBCLK generation in master mode): 0h=Auto 1h = 32x Fs 2h = 40x Fs 3h = 64x Fs
	5	RSVD	0h	Reserved
	4:3	DBR	2h	DAC Base Rate 0h = 32kHz 1h = 44.1kHz 2h = 48kHz 3h = Reserved
	2:0	DBM	2h	DAC Base Rate Multiplier 0h = 0.25x 1h = 0.5x 2h = 1x 3h = 2x 4h-7h = Reserved

Table 40. Internal Sample Rate Control Register

TSCS42XX

Portable Consumer CODECs

Internal Sample Rates

IBR [1:0]	xBM [2:0]	BASE RATE	SAMPLE RATE
0	00	56.448MHz	11.025kHz(MCLK/5120)
	01		22.050kHz(MCLK/2560)
	10		44.1 kHz (MCLK/1280)
	11		88.2 kHz (MCLK/640)
1	00	61.44 MHz	22kHz(MCLK/5120)
	01		24kHz(MCLK/2560)
	10		48 kHz (MCLK/1280)
	11		96 kHz (MCLK/640)

7.2.3.3. MCLK2 Pin

The MCLK2 pin can be configured to be input. It can provide a clock to drive the input to the PLL's or or the I2S Master Mode clock generators.

MCLK2 Pin Control Register

Register Address	Bit	Label	Type	Default	Description
Page 0, Reg 33-21h MCLK2PINC	7:4	SLEWOUT[3:0]	RW	1000b	Slew rate setting for MCLK2 Output
	3	RSVD	R	0	Reserved
	2	MCLK2IO	RW	0	Configure MCLK2 as input or output. 0 = MCLK2 pin is an input 1 = MCLK2 pin is an output
	1:0	MCLK2OS[1:0]	RW	01b	MCLK2 Pin Output Clock Select 00 = 24.576 MHz 01 = 22.5792 MHz 10 = PLL2 ¹ 11 = Reserved

1. The maximum supported output frequency for MCLK2 is 50MHz

7.2.3.4. I2S Master Mode Clock Generation

I2S input audio source can operate as a timing Slave or Master. When operated in Master Mode an internal clock generator is used to produce the required bit and frame clocks to be driven out of the LRCLK and BCLK pins of each input I2S interface. The clock source for the I2S master clock generation can be selected between the PLL generated internal timing or an externally supplied clock via the MCLK2 input.

7.2.3.5. I2S Master Mode Sample Rate Control

These registers set the I2S Master Mode sample rates. For normal operation the PLL1 and PLL2 outputs are used for gen-

TSCS42XX

Portable Consumer CODECs

erating the timing for the I2S port when operating in Master Mode. Optionally the MCLK2 input may be used for generating the timing for the I2S port when operating in Master Mode. External MCLK timing mode is selected when the MBR[1:0] bits are set to 11. In this mode the MCLK/2 and MCLKDIV[1:0] bits become active. The MBM[2:0] bits are also active in this mode. The I2SMBR bits set the base audio sample to be either 44.1Khz or 48KHz. The I2SMBM bits are then used to set the base rate multiplier ratio. When the MCLK2 input is selected as a clocks source for the I2S Master Mode clock generation the I2SMCLK/2 and I2SMCLKDIV[1:0] bits are used to divide down the MCLK2 input to the desired audio sample rate.

I2S MasterMode Control Registers

Register Address	Bit	Label	Default	Description
R19(13h)AIC1	7	RESERVED	0h	Reserved
	6	BCLKINV	0h	BCLK Invert (master and slave modes): 1 = BCLK inverted 0 = BCLK not inverted
	5	MS	0h	Master/Slave Control: 0 = Slave; 1 = Master
	4	LRP	0h	LRCIk Polarity: 0 = Not inverted; 1 = Inverted
	3:2	WL	2h	Audio Data Word Length: 0h = 16 bits; 1h = 20 bits; 2h = 24 bits; 3h = 32 bits
	1:0	FORMAT	2h	Audio Data Format: 0h = Right justified; 1h = Left justified; 2h = I2S 3h = Reserved

Table 41. I2S Master Mode Rate Control Register

The table below shows the typical I2S Master Mode Audio Sample Rates when using the BCLK input as the input clock source.

TSCS42XX
Portable Consumer CODECs

MCLK2(MHZ)	MCLK/2	MCLKDIV[1:0]	MBM [2:0]	SAMPLE RATE(KHz)	ERROR
24.576	/2	128	000	12	0
			001	24	0
			010	48	0
			011	96	0
		192	000	8	0
			001	16	0
			010	32	0
			011	64	0
12.288	/1	128	000	12	0
			001	24	0
			010	48	0
			011	96	0
		192	000	8	0
			001	16	0
			010	32	0
			011	64	0
24.000	/2	125	000	12	0
			001	24	0
			010	48	0
			011	96	0
		136	000	11.0294	.04%
			001	22.0588	.04%
			010	44.1176	.04%
			011	88.235	.04%
12.000	/1	125	000	12	0
			001	24	0
			010	48	0
			011	96	0
		135	000	11.0294	.04%
			001	22.0588	.04%
			010	44.1176	.04%
			011	88.235	.04%

TSCS42XX

Portable Consumer CODECs

MCLK2(MHZ)	MCLK/2	MCLKDIV[1:0]	MBM [2:0]	SAMPLE RATE(KHz)	ERROR
22.5792	/2	128	000	11.025	0
			001	22.050	0
			010	44.1	0
			011	88.2	0
11.2896	/1	128	000	11.025	0
			001	22.050	0
			010	44.1	0
			011	88.2	0
16.384	/2	128	000	8.0	0
			001	16.0	0
			010	32.0	0
			011	64.0	0

Preliminary

7.2.3.6. DAC/ADC Clock Control

The power consumption and audio quality may be adjusted by changing the converter modulator rate. By default the DAC and ADC Sigma-Delta modulators run at a high rate for the best audio quality. The modulator rates for the converters may be forced to run at half their nominal rate to conserve power. A third option allows the modulator rate to automatically drop to half rate when low sampling rates are chosen (1/2 or 1/4 the base rate.) The DACs and ADCs are independently coco-

TSCS42XX

Portable Consumer CODECs

trolled.

Register Address	Bit	Label	Type	Default	Description
R31(1Fh) CONFIG0	7:6	ASDM[1:0]	RW	2h	ADC Modulator Rate 00b = Reserved 01b = Half 10b = Full 11b = Auto
	5:4	DSDM[1:0]	RW	2h	DAC Modulator Rate 00b = Reserved 01b = Half 10b = Full 11b = Auto
	3:2	RSVD	R	0	Reserved
	1	DC_BYPASS	RW	0h	DAC DC Filter Bypass: 0 = Filter enable 1 = Filter bypassed
	0	SD_FORCE_ON	RW	0h	Supply Detect Force On: 0 = Supply detect not forced on 1 = Supply detect forced on Note If not forced on, the supply detect logic will automatically be enabled when features that use it are enabled (COP,UVLO)

Table 42. DAC/ADC Clock Control

ADC and DAC Modulator Rates

DSDM[1:0] ASDM[1:0]	BM [2:0]	Modulator Rate
00	NA	Reserved
01	000 (1/4x)	Half
	001 (1/2x)	
	010 (1x)	
	011 (2x)	
10	000 (1/4x)	Full
	001 (1/2x)	
	010 (1x)	
	011 (2x)	
11	000 (1/4x)	Auto (Half)
	001 (1/2x)	Auto (Half)
	010 (1x)	Auto (Full)
	011 (2x)	Auto (Full)

7.2.3.7.TMBASE - Timebase Register

Register Address	Bit	Label	Type	Default	Description
R119(77h) TMBASE	7-0	TIMEBASE[7:0]	RW	2F	Internal Time Base Divider. This value should be programmed as $\lceil \text{round}(\text{ref clock}/256000) \rceil - 1$

Table 43. Time Base Register

Preliminary

8. CHARACTERISTICS

8.1. Electrical Specifications

8.1.1. Absolute Maximum Ratings

Stresses above the ratings listed below can cause permanent damage to the TSC42XX. These ratings, which are standard values for TSI commercially rated parts, are stress ratings only. Functional operation of the device at these or any other conditions above those indicated in the operational sections of the specifications is not implied. Exposure to absolute maximum rating conditions for extended periods can affect product reliability. Electrical parameters are guaranteed only over the recommended operating temperature range.

Item	Maximum Rating
Voltage on any pin relative to Ground	Vss - 0.3V TO Vdd + 0.3V
Operating Temperature	0 °C TO 70 °C
Storage Temperature	-55 °C TO +125 °C
Soldering Temperature	260 °C
MICBias Output Current	3mA
Amplifier Maximum Supply Voltage	6 Volts = PVDD
Audio Maximum Supply Voltage	3 Volts = AVDD/CPVDD
Digital I/O Maximum Supply Voltage	3.6 Volts = DVDD_IO
Digital Core Maximum Supply Voltage	2.0 Volts = DVDD

Table 43. Electrical Specification: Maximum Ratings

8.1.2. Recommended Operating Conditions

Parameter		Min.	Typ.	Max.	Units
Power Supplies	DVDD_Core	1.4		2.0	V
	DVDD_IO	1.4		3.5	
	AVDD/CPVDD	1.7		2.0	
	PVDD	3.0		5.5	V
Ambient Operating Temperature	Analog - 5 V	0	25	70	°C
Case Temperature	T _{case}			90	°C

Table 44. Recommended Operating Conditions

ESD: The TSC42XX is an ESD (electrostatic discharge) sensitive device. The human body and test equipment can accumulate and discharge electrostatic charges up to 4000 Volts without detection. Even though the TSC42XX implements internal ESD protection circuitry, proper ESD precautions should be followed to avoid damaging the functionality or performance.

8.2. Device Characteristics

($T_{\text{ambient}} = 25\text{ }^{\circ}\text{C}$, $DVDD_{\text{CORE}}=DVDD_{\text{IO}}=AVDD=1.9\text{V}$, $PVDD=3.6\text{V}$, 997Hz signal, $f_s=48\text{KHz}$, Input Gain=0dB, 24-bit audio)

Parameter	Symbol	Test Conditions	Min	Typ	Max	Unit
Analog Inputs (L_{IN1}, L_{IN2}, L_{IN3}, R_{IN1}, R_{IN2}, R_{IN3})						
Full Scale Input Voltage	V_{FSIV}	$L/R_{IN1,2,3}$ Single Ended		0.5 -6		Vrms dBV
		$L/R_{IN1,2,3}$ Differential Mic		0.5 -6		Vrms dBV
Input Impedance				50		Kohm
Input Capacitance				10		pF
Analog Input Boost Amplifier						
Programmable Gain Min				0.0		dB
Programmable Gain Max				30.0		dB
Programmable Gain Step Size				10.0		dB
Analog Input PGA						
Programmable Gain Min				-17.25		dB
Programmable Gain Max				30.0		dB
Programmable Gain Step Size		Guaranteed Monotonic		0.75		dB
Digital Volume Control Amplifier						
Programmable Gain Min				-97		dB
Programmable Gain Max				30.0		dB
Programmable Gain Step Size		Guaranteed Monotonic		0.5		dB
Mute Attenuation				-999		dB
Analog Inputs (L_{IN1}/R_{IN1}, L_{IN2}/R_{IN2} Differential) to ADC						
Signal To Noise Ratio	SNR	A-weighted 20-20KHz		90		dB
Total Harmonic Distortion + Noise	THD+N	-1dBFS input		-80 0.01		dB %
Analog Inputs (L_{IN1}, L_{IN2}, L_{IN3}, R_{IN1}, R_{IN2}, R_{IN3} Single Ended) to ADC						
Signal To Noise Ratio	SNR	A-weighted 20-20KHz		90		dB
Total Harmonic Distortion + Noise	THD+N	-1dBFS input		-80 0.01		dB %
ADC channel Separation		997Hz full scale signal		70		dB
Channel Matching		997Hz signal			2	%
DAC to Line-Out (HPL, HPR with 10K / 50pF load)						
Signal to Noise Ratio ¹	SNR	A-weighted		102		dB
Total Harmonic Distortion +Noise ²	THD+N	997Hz full scale signal		-84		dB
Channel Separation		997Hz full scale signal		70		dB
Mute attenuation				-999		dB
Headphone Outputs (HPL, HPR)						
Full Scale Output Level	V_{FSOV}	$R_L = 10\text{Kohm}$		1.0		Vrms
		$R_L = 16\text{ohm}$		0.75		Vrms
Output Power	P_O	997Hz full scale signal, $R_L = 16\text{ohm}$		35		mW (ave)
Signal to Noise Ratio	SNR	A-weighted, $R_L = 16\text{ohm}$		102		dB

Table 45. Device Characteristics

TSCS42XX

Portable Consumer CODECs

Parameter	Symbol	Test Conditions	Min	Typ	Max	Unit
Total Harmonic Distortion +Noise	THD+N	R _L = 16ohms, -3dBFS		-76		dB
		R _L = 32ohms, -3dBFS		-78		dB
Speaker Outputs (L+, L-, R+, R- with 8ohms bridge-tied load)						
Full Scale Output Level	V _{F_{SOV}}	PVDD=5V PVDD=3.6V		3.0 2.1		V _{rms}
Output Power	P _O	997Hz full scale signal, output power mode disabled PVDD=5V, 8ohm PVDD=3.6V, 8ohm		1.5 7		W(ave)
		PVDD = 5V, 4 ohm DIDD = 3.6V, 4 ohm		3 1.4		W(ave)
Signal to Noise Ratio	SNR	A-weighted		90		dB
Total Harmonic Distortion + Noise	THD+N	5V/8ohms/0.5W		0.05		%
Speaker Supply Leakage Current	I _{PVDD}			1		uA
Efficiency	h	PVDD=3.6V RL=8,P _O = 0.5W PVDD=5V RL=8,P _O = 1W		92		%
Analog Voltage Reference Levels						
Charge Pump Output	V-		-5%	-AVDD +100mV	+5%	V
Microphone Bias						
Bias Voltage	V _{MICBIAS}		-	2.5	-	V
BIAS current Source					3	mA
Power Supply Rejection Ratio	PSRR _{MICBIAS}	3.3V<PVDD<5.25V		80		dB
		3.0V<PVDD<3.3V		40		dB
Digital Input/Output						
ADC/DAC BCLK input rate	F _{max}			30		MHz
I2S BCLK/LRCLK ratio			32		1022	clocks/ frame
Input High Level	V _{IH}		0.7x DVDD_ IO			V
Input LOW Level	V _{IL}				0.3x DVDD_IO	V
Output High Level	V _{OH}	I _{OH} =-1mA	0.9x DVDD_IO			V
Output LOW Level	V _{OL}	I _{OL} =1mA		0.1xDVDD_IO		V
Input Capacitance				5		pF
Input Leakage			-0.9		0.9	uA
Internal Pull-Up Resistor	R _{PU} / R _{PU}	All Digital I/O pins with pull-up or pull-down		50		kΩ
ESD / Latchup						
IEC1000-4-2			1			Level
JESD22-A114-B			2			Class
JESD22-C101			4			Class

Table 45. Device Characteristics

1. Ratio of Full Scale signal to idle channel noise output is measured "A weighted" over a 20 Hz to a 20 kHz bandwidth. (AES17-1991 Idle Channel Noise or EIAJ CP-307 Signal-to-noise Ratio).

2. THD+N ratio as defined in AES17 and outlined in AES6id, non-weighted, swept over 20 Hz to 20 kHz bandwidth.

8.3. Electrical Characteristics

Unless stated otherwise, DVDD_Core=1.8V -0.1V/+0.2V, Ambient Temp -10C to +80C

Parameter	Symbol	Test Conditions	Min	Typ	Max	Unit
Operating Voltage	DVDD_CORE		1.7	1.8	2.0	V
Supply Current	I _{DVDD_CORE(PLL)}	No Load, VDD=1.9V		11	15	mA
Input High Level	V _{IH}		0.7x DVDD_CORE			V
Input LOW Level	V _{IL}				0.3xDVDD_CORE	V
Input Capacitance	C _{IN}			5		pF
Load Capacitance, X1 and X2	C _L			5		pF
Output High Level	V _{OH}	I _{OH} =-2mA	0.8x DVDD_CORE			V
Output LOW Level	V _{OL}	I _{OL} =2mA			0.2xDVDD_CORE	V
Power Up Time	t _{PU}	From minimum VDD to outputs stable		1.5	4	ms
Output Enable Time					20	ns
Output Disable Time					20	ns

Table 46. PLL Section DC Characteristics

TSCS42XX

Portable Consumer CODECs

9. REGISTER MAP

Table 12.1 Register Map

Register (D15:9)	Name	Remarks	Bit[7]	Bit[6]	Bit[5]	Bit[4]	Bit[3]	Bit[2]	Bit[1]	Bit[0]	Default
R0 (00h)	HPVOLL	Left HP volume	HPVOL_L[6:0]								79h
R1 (01h)	HPVOLR	Right HP volume	HPVOL_R[6:0]								79h
R2 (02h)	SPKVOLL	SPKR Left volume	SPKVOL_L[6:0]								6Fh
R3 (03h)	SPKVOLR	SPKR Right volume	SPKVOL_R[6:0]								6Fh
R4 (04h)	DACVOLL	Left DAC volume	DACVOL_L[7:0]								FFh
R5 (05h)	DACVOLR	Right DAC volume	DACVOL_R[7:0]								FFh
R6 (06h)	ADCVOLL	Left ADC volume	ADCVOL_L[7:0]								BFh
R7 (07h)	ADCVOLR	Right ADC volume	ADCVOL_R[7:0]								BFh
R8 (08h)	INVOLL	Left Input volume		IZCL	INVOL_L						17h
R9 (09h)	INVOLR	Right Input volume		IZCR	INVOL_R						17h
R10 (0Ah)	VUCTL	Volume Update Control	ADCFade	DACFade		INVOLU	ADCVOLU	DACVOLU	SPKVOLU	HPVOLU	C0h
R11 (0Bh)	INMODE	ADC input mode								DS	00h
R12 (0Ch)	INSELL	ADCL signal path	INSEL_L[1:0]		MICBST_L[1:0]					00h	
R13 (0Dh)	INSELR	ADCR signal path	INSEL_R[1:0]		MICBST_R[1:0]					00h	
R14 (0Eh)	ALC0	ALC0					ALC MODE	ALCSEL[1:0]		00h	
R15 (0Fh)	ALC1	ALC1			MAXGAIN[2:0]		ALCL[3:0]		7Bh		
R16 (10h)	ALC2	ALC2			MINGAIN[2:0]		HLD[3:0]		00h		
R17 (11h)	ALC3	ALC3			DCY[3:0]		ATK[3:0]		32h		
R18 (12h)	NGATE	Noise Gate			NGTH[4:0]		NGG[1:0]		NGAT	00h	
R19 (13h)	AIC1	Audio Interface 1		BCLKINV	MS	LRP	WL[1:0]		FORMAT[1:0]		0Ah
R20 (14h)	AIC2	Audio Interface 2	DACDSEL[1:0]		ADCDSEL[1:0]		TRI	BLRCM[2:0]			00h
R21 (15h)	AIC3	Audio Interface 3			ADOPDD	ALRPDD	ABCPDD	DDIPDD	DLRPDD	DBCPDD	00h
R22 (16h)	CNVTR0	ADC Control	ADCPOLR	ADCPOLL	AMONOMIX[1:0]		ADCMU	HPOR	ADCHPDR	ADCHPDL	08h
R23 (17h)	ADCSR	ADC Sample rate	ABCM[1:0]		ABR[1:0]		ABM[2:0]			12h	
R24 (18h)	CNVTR1	DAC Control	DACPOLR	DACPOLL	DMONOMIX[1:0]		DACMU	DEEMPH	08h		
R25 (19h)	DACSR	DAC Sample rate	DBCM[1:0]		DBR[1:0]		DBM[2:0]			12h	
R26 (1Ah)	PWRM1	Pwr Mgmt (1)	BSTL	BSTR	PGAL	PGAR	ADCL	ADCR	MICB	DIGENB	00h
R27 (1Bh)	PWRM2	Pwr Mgmt (2)	D2S	HPL	HPR	SPKL	SPKR	VREF		00h	
R28 (1Ch)	CTL	Additional control	HPSWEN	HPSWPOL	EQ2SW1	EQ2SW0	EQ1SW1	EQ1SW0	TSDEN	TOEN	00h
R29 (1Dh)	THERMTS	Temp Sensor Control	TripHighStat	TripLowStat	TripSplit[1:0]		TripShift[1:0]		Poll[1:0]		09h
R30 (1Eh)	THERMSPKR1	Speaker Thermal Algorithm Control	ForcePwD	InstCutMode	IncRatio[1:0]		IncStep[1:0]		DecStep[1:0]		81h
R31 (1Fh)	CONFIG0	CONFIG0	ASDM1	ASDM0	DSDM1	DSDM0	dc_bypass		sd_force_on	A0h	
R32 (20h)	CONFIG1	CONFIG1	EQ2_EN	EQ2_BE2	EQ2_BE1	EQ2_BE0	EQ1_EN	EQ1_BE2	EQ1_BE1	EQ1_BE0	00h
R33 (21h)	GAINCTL	Gain Control	zerode_t_flag		zerodellen 1	zerodellen 0	auto_mute		24h		
R34 (22h)	COP1	Constant Output Power1	COPAtten	COPGain	HDeltaEn	COPTarget[4:0]				08h	
R35 (23h)	COP2	Constant Output Power2		HDCOMP MODE	AvgLength[3:0]			MonRate[1:0]		02h	
R36 (24h)	DMICCTL	D-Mic Control	DMicEn			DMono	DMPAdj1	DMPAdj0	DMRate1	DMRate0	00h
R37 (25h)	CLECTL	CMLPMTCTL				Lvl_Mode	WindowSel	Exp_En	Limit_En	Comp_En	00h
R38 (26h)	MUGAIN	CLEMakeUpGain				CLEMUG4	CLEMUG3	CLEMUG2	CLEMUG1	CLEMUG0	00h
R39 (27h)	COMPTh	Compressor Threshold	COMPTh7	COMPTh6	COMPTh5	COMPTh4	COMPTh3	COMPTh2	COMPTh1	COMPTh0	00h
R40 (28h)	CMPRAT	Compressor Ratio				CMPRAT4	CMPRAT3	CMPRAT2	CMPRAT1	CMPRAT0	00h
R41 (29h)	CATKTC	Comp Attack time const Low	CATKTC7	CATKTC6	CATKTC5	CATKTC4	CATKTC3	CATKTC2	CATKTC1	CATKTC0	00h

TSCS42XX

Portable Consumer CODECs

Register (D15:9)	Name	Remarks	Bit[7]	Bit[6]	Bit[5]	Bit[4]	Bit[3]	Bit[2]	Bit[1]	Bit[0]	Default	
R42(2Ah)	CATKTCH	Comp Attack time const High	CATKTC15	CATKTC14	CATKTC13	CATKTC12	CATKTC11	CATKTC10	CATKTC9	CATKTC8	00h	
R43 (2Bh)	CRELTCL	Comp release time const Low	CRELTC7	CRELTC6	CRELTC5	CRELTC4	CRELTC3	CRELTC2	CRELTC1	CRELTC0	00h	
R44 (2Ch)	CRELTCH	Comp release time const High	CRELTC15	CRELTC14	CRELTC13	CRELTC12	CRELTC11	CRELTC10	CRELTC9	CRELTC8	00h	
R45 (2Dh)	LIMTH	Limiter Threshold	LIMTH7	LIMTH6	LIMTH5	LIMTH4	LIMTH3	LIMTH2	LIMTH1	LIMTH0	00h	
R46 (2Eh)	LIMTGT	Limiter Target	LIMTGT7	LIMTGT6	LIMTGT5	LIMTGT4	LIMTGT3	LIMTGT2	LIMTGT1	LIMTGT0	00h	
R47 (2Fh)	LATKTCL	Limiter Attack time constant Low	LATKTC7	LATKTC6	LATKTC5	LATKTC4	LATKTC3	LATKTC2	LATKTC1	LATKTC0	00h	
R48 (30h)	LATKTCH	Limiter Attack time constant High	LATKTC15	LATKTC14	LATKTC13	LATKTC12	LATKTC11	LATKTC10	LATKTC9	LATKTC8	00h	
R49 (31h)	LRELTCL	Limiter Release time constant Low	LRELTC7	LRELTC6	LRELTC5	LRELTC4	LRELTC3	LRELTC2	LRELTC1	LRELTC0	00h	
R50 (32h)	LRELTCH	Limiter Release time constant High	LRELTC15	LRELTC14	LRELTC13	LRELTC12	LRELTC11	LRELTC10	LRELTC9	LRELTC8	00h	
R51 (33h)	EXPTH	Expander Threshold	EXPTH7	EXPTH6	EXPTH5	EXPTH4	EXPTH3	EXPTH2	EXPTH1	EXPTH0	00h	
R52 (34h)	EXPRAT	Expander Ratio						EXPRAT2	EXPRAT1	EXPRAT0	00h	
R53 (35h)	XATKTCL	Expander Attack time constant Low	XATKTC7	XATKTC6	XATKTC5	XATKTC4	XATKTC3	XATKTC2	XATKTC1	XATKTC0	00h	
R54 (36h)	XATKTCH	Expander Attack time constant High	XATKTC15	XATKTC14	XATKTC13	XATKTC12	XATKTC11	XATKTC10	XATKTC9	XATKTC8	00h	
R55 (37h)	XRELTCL	Expander Release time constant Low	XRELTC7	XRELTC6	XRELTC5	XRELTC4	XRELTC3	XRELTC2	XRELTC1	XRELTC0	00h	
R56 (38h)	XRELTCH	Expander Release time constant High	XRELTC15	XRELTC14	XRELTC13	XRELTC12	XRELTC11	XRELTC10	XRELTC9	XRELTC8	00h	
R57 (39h)	FXCTL	Effects Control				3DEN	TEEN	TNLFBYP	BEEN	BNLFBYP	00h	
R58 (3Ah)	DACCRWRL	DACCRAM_WRITE_LO									00h	
R59 (3Bh)	DACCRWRM	DACCRAM_WRITE_MID									00h	
R60 (3Ch)	DACCRWRH	DACCRAM_WRITE_HI									00h	
R61 (3Dh)	DACCRDDL	DACCRAM_READ_LO									00h	
R62 (3Eh)	DACCRDDM	DACCRAM_READ_MID									00h	
R63 (3Fh)	DACCRDDH	DACCRAM_READ_HI									00h	
R64 (40h)	DACCRADDR	DACCRAM_ADDR									01h	
R65 (41h)	DCOFSEL	DC_COEF_SEL								dc_coef_sel[2:0]	05h	
R66 (42h)	PWM0	PWM Control 0	SCTO1	SCTO0	UVLO	roundup	bfclr	fourthorder	add3_sel	quantizer_sel	C4h	
R67 (43h)	PWM1	PWM Control 1		dithpos4	dithpos3	dithpos2	dithpos1	dithpos0	dith_range	dithclr	12h	
R68 (44h)	PWM2	PWM Control 2	dvalue5	dvalue4	dvalue3	dvalue2	dvalue1	dvalue0		pwm_outmode	00h	
R69 (45h)	PWM3	PWM Control 3	outctrl1	outctrl0	cvalue5	cvalue4	cvalue3	cvalue2	cvalue1	cvalue0	06h	
R78 (4Eh)	PLLCTL9	PLL Control 9									refdiv_pll1[7:0]	05h
R79 (4Fh)	PLLCTLA	PLL Control 10									outdiv_pll1[7:0]	03h
R80 (50h)	PLLCTLB	PLL Control 11									fbdiv_pll1[7:0]	72h
R81 (51h)	PLLCTLC	PLL Control 12									fbdiv_pll1[10:8]	03h
R82 (52h)	PLLCTLD	PLL Control 13					rz_pll1[1:0]			cp_pll1[2:0]	22h	
R83 (53h)	PLLCTLE	PLL Control 14									refdiv_pll2[7:0]	12h
R84 (54h)	PLLCTLF	PLL Control 15									outdiv_pll2[7:0]	03h
R85 (55h)	PLLCTL10	PLL Control 16									fbdiv_pll2[7:0]	1Ch
R86 (56h)	PLLCTL11	PLL Control 17									fbdiv_pll2[10:8]	02h
R87 (57h)	PLLCTL12	PLL Control 18					rz_pll2[1:0]			cp_pll2[2:0]	1Ah	
R96 (60h)	PLLCTL1B	PLL Control 27		vcoi_pll3		vcoi_pll2		vcoi_pll1		vcoi_pllss	14h	
R97 (61h)	PLLCTL1C	PLL Control 28					pdb_pll3	pdb_pll2	pdb_pll1	pdb_pllss	0Fh	
R103(67h)	PLLCTL22	PLL Control 34				C_XTAL[4:0]		pll3_vco_sel	pll2_vco_sel	pll1_vco_sel	38h	
R104(68h)	DTEST0	Digital Test 0									TBD	00h
R105(69h)	DTEST1	Digital Test 1									TBD	00h
R106(6Ah)	ATEST0	Analog Test 0									TBD	00h
R107(6Bh)	ATEST1	Analog Test 1									TBD	00h
R108(6Ch)	ATEST2	Analog Test 2									TBD	00h

TSCS42XX

Portable Consumer CODECs

Register (D15:9)	Name	Remarks	Bit[7]	Bit[6]	Bit[5]	Bit[4]	Bit[3]	Bit[2]	Bit[1]	Bit[0]	Default	
R109(6Dh)	ATEST3	Analog Test 3					TBD				00h	
R110(6Eh)	ATEST4	Analog Test 4					TBD				00h	
R111(6Fh)	ATEST5	Analog Test 5					TBD				00h	
R112(70h)	ATEST6	Analog Test 6					TBD				00h	
R113(71h)	ATEST7	Analog Test 7					TBD				00h	
R114(72h)	ATEST8	Analog Test 8					TBD				00h	
R115(73h)	ATEST9	Analog Test 9					TBD				00h	
R116(74h)	ATEST10	Analog Test 10					TBD				00h	
R117(75h)	ATEST11	Analog Test 11					TBD				00h	
R118(76h)	ATEST12	Analog Test 12					TBD				00h	
R119(77h)	TIMEBASE	Divider					TIMEBASE[7:0]				61h	
R120(78h)	MFG0	OTP					OTPVER[7:0]				00h	
R121(79h)	MFG1	X coordinate					MAPX[5:0]				NA	
R122(7Ah)	MFG2	Y coordinate					MAPY[5:0]				NA	
R123(7Bh)	MFG3	Wafer #					WAFER[4:0]				NA	
R124(7Ch)	DEVADR	I2C Device Address	ADDR7	ADDR6	ADDR5	ADDR4	ADDR3	ADDR2	ADDR1	ADDR0	D2h	
R125(7Dh)	DEVIDL	Device ID Low	DID7	DID6	DID5	DID4	DID3	DID2	DID1	DID0	01h	
R126(7Eh)	DEVIDH	Device ID High	DID15	DID14	DID13	DID12	DID11	DID10	DID9	DID8	00h	
R127(7Fh)	REVID	Device Revision	MAJ3	MAJ2	MAJ1	MAJ0	MNR3	MNR2	MNR1	MNR0	11h	
R128(80h)	RESET	Reset	Writing 0x85 to this register resets all registers to their default state									00h
R136(88h)	THERMSPKR2	Speaker Thermal Algorithm Status	ForcePwD Status	VolStatus[6:0]								08h
R137(89h)	COP3	Constant Output Power Status	HighDelta	UNDER VOLTAGE	COPAdj[5:0]							00h
R138(8Ah)	DACCSTAT	DACCGRAM_STATUS	DACCR_Busy								00h	
R139(8Bh)	HPDETSTAT	HP detect pin status	HP_Detect								00h	
R140(8Ch)	ADCALCSTAT	ALC Volume status			PGA_GAIN5	PGA_GAIN4	PGA_GAIN3	PGA_GAIN2	PGA_GAIN1	PGA_GAIN0	00h	
R141(8Dh)	SD_STAT				SDVALUE4	SDVALUE3	SDVALUE2	SDVALUE1	SDVALUE0		00h	
R142(8Eh)	PLLCTL0	PLL Control 0	gpout3	gpout2	gpout1	gpout0	pllss_lock	pll3_lock	pll2_lock	pll1_lock	00h	
R143(8Fh)	PLLREFSEL	PLL Control	PLL2_REF				PLL1_REF					00h
R144(90h)	BISTCTL	BIST Control									00h	
R145(91h)	BISTSTAT1	BIST Status 1									00h	
R146(92h)	BISTSTAT2	BIST Status 2									00h	
R147(93h)	BISTSTAT3	BIST Status 3									00h	
R148(94h)	BISTSTAT4	BIST Status 4									00h	
R149(95h)	BISTSTAT5	BIST Status 5									00h	
R160(A0h)	ATEST13	Analog Test 13									00h	
R161(A1h)	ATEST14	Analog Test 14									00h	
R162(A2h)	ATEST15	Analog Test 15									00h	
R163(A3h)	ATEST16	Analog Test 16									00h	
R164(A4h)	ATEST17	Analog Test 17									00h	
R165(A5h)	ATEST18	Analog Test 18	SPARE							pll1_ibias_1	pll2_ibias_1	00h
R176(B0h)	TESTSTAT0	Test Status 0									00h	
R192(C0h)	GPIOCTL1	GPIO CONTROL			GPIOFG1	GPIOFG0			GPIODIR1	GPIODIR0	00h	
R193(C1h)	GPIOCTL2	GPIO CONTROL							GPIOPU1	GPIOPU0	00h	
R194(C2h)	GPIODATA	GPIO CONTROL			GPIODAT1	GPIODAT0			GPIOPIN1	GPIOPIN0	00h	
R195(C3h)	ADPCMCCTL1	ADC PCM CONTROL1	GAINCODE			GAINENA B	BDELAYO	PCMFL	SLSYNC		00h	
R196(C4h)	ADPCMCCTL2	ADC PCM CONTROL2	PCMFORM	PCMMOM	PCMSO	PCMDSS					00h	
R197(C5h)	DACPCMCCTL1	DAC PCM CONTROL1					BDELAYI	PCMFL	SLSYNC		00h	
R198(C6h)	DACPCMCCTL2	DAC PCM CONTROL2	PCMFORM	PCMMIM	PCMSI	PCMDSS		PCMSIGNI	PCM13MO		00h	

TSCS42XX

Portable Consumer CODECs

Register (D15:9)	Name	Remarks	Bit[7]	Bit[6]	Bit[5]	Bit[4]	Bit[3]	Bit[2]	Bit[1]	Bit[0]	Default
R199(C7h)	DACMBCEN	Multi-Band SELECTOR						MBCEN3	MBCEN2	MBCEN1	00h
R200(C8h)	DACMBCCTL	Multi-Band SELECTOR			LVLMODE	WINSEL3	LVLMODE	WINSEL2	LVLMODE	WINSEL1	00h
R201(C9h)	DACMBCMUG1	Multi-Band SELECTOR			PHASE	MUGAIN				00h	
R202(CAh)	DACMBCTHR1	COMPRESSOR	THRESH								00h
R203(CBh)	DACMBCRAT1	COMPRESSOR	RATIO								00h
R204(CCh)	DACMBCATK1L	COMPRESSOR	TCATKL								00h
R205(CDh)	DACMBCATK1H	COMPRESSOR	TCATKH								00h
R206(CEh)	DACMBCREL1L	COMPRESSOR	TCRELL								00h
R207(CFh)	DACMBCREL1H	COMPRESSOR	TCRELH								00h
R208(D0h)	DACMBCMUG2	Multi-Band 2SELECTOR			PHASE	MUGAIN				00h	
R209(D1h)	DACMBCTHR2	COMPRESSOR 2	THRESH								00h
R210(D2h)	DACMBCRAT2	COMPRESSOR 2	RATIO								00h
R211(D3h)	DACMBCATK2L	COMPRESSOR 2	TCATKL								00h
R212(D4h)	DACMBCATK2H	COMPRESSOR 2	TCATKH								00h
R213(D5h)	DACMBCREL2L	COMPRESSOR 2	TCRELL								00h
R214(D6h)	DACMBCREL2H	COMPRESSOR 2	TCRELH								00h
R215(D7h)	DACMBCMUG3	Multi-Band 3 SELECTOR			PHASE	MUGAIN				00h	
R216(D8h)	DACMBCTHR3	COMPRESSOR 3	THRESH								00h
R217(D9h)	DACMBCRAT3	COMPRESSOR 3	RATIO								00h
R218(DAh)	DACMBCATK3L	COMPRESSOR 3	TCATKL								00h
R219(DBh)	DACMBCATK3H	COMPRESSOR 3	TCATKH								00h
R220(DCh)	DACMBCREL3L	COMPRESSOR 3	TCRELL								00h
R221(DDh)	DACMBCREL3H	COMPRESSOR 3	TCRELH								00h

Note:

- Registers not described in this map should be considered “reserved”.
- Numerous portions of the register map are compatible with popular codecs from other vendors.

10. PIN INFORMATION

10.1. TSCS42A1 Pin Diagram

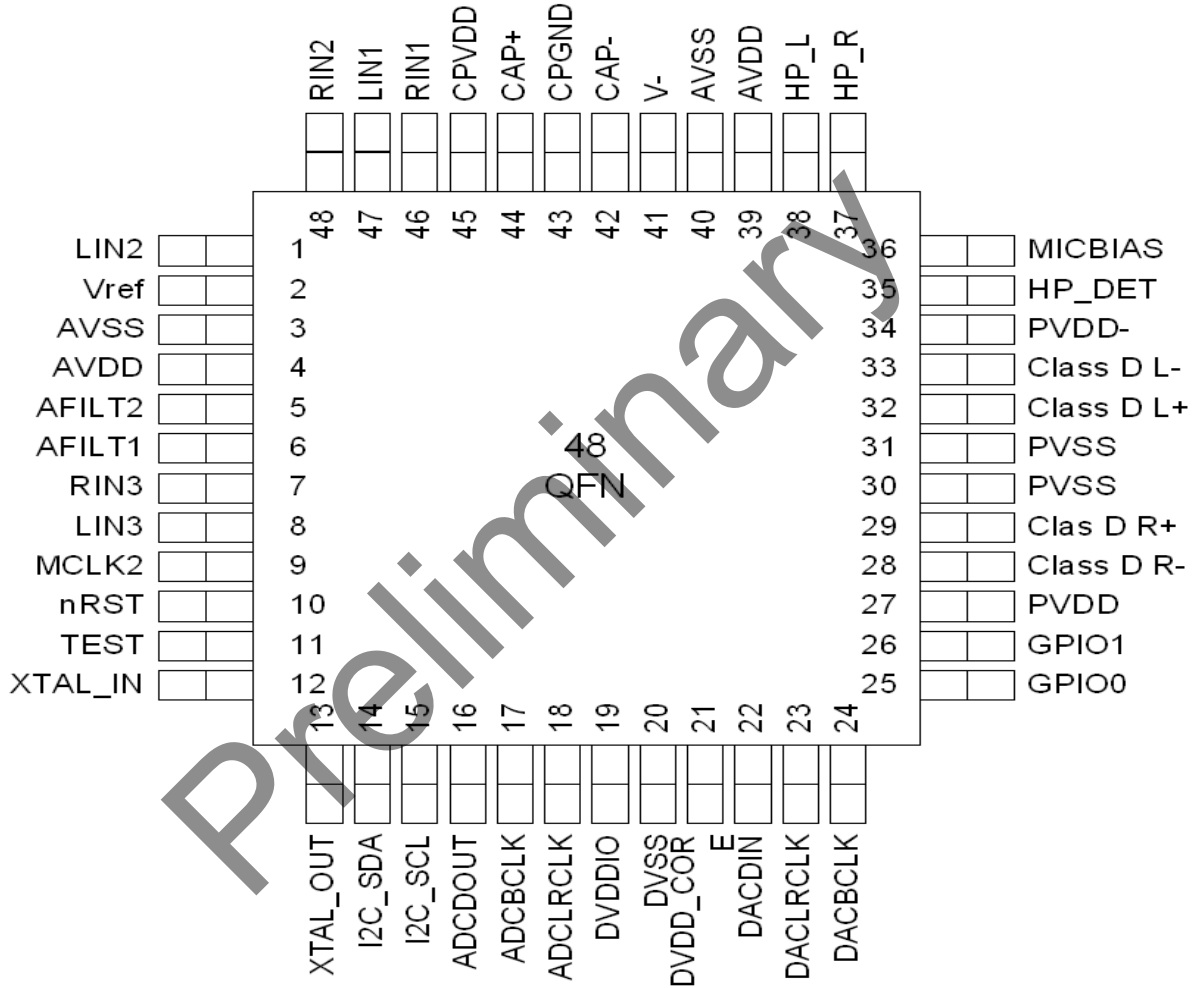

Figure 22. 48QFN Pin Assignment

10.2. TSCS42A2 Pin Diagram

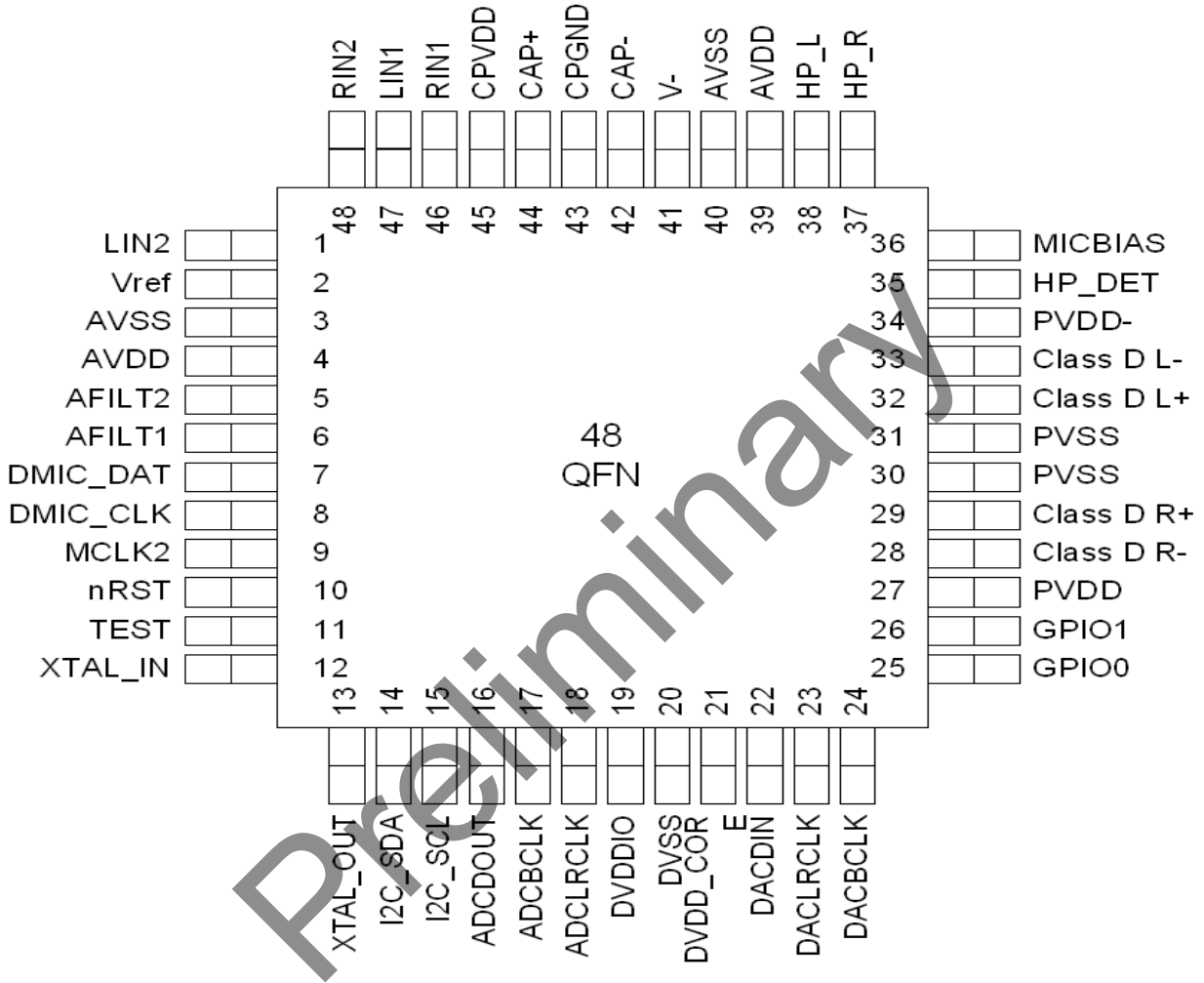

Figure 23. 48QFN Pin Assignment

10.3. TSCS42A3 Pin Diagram

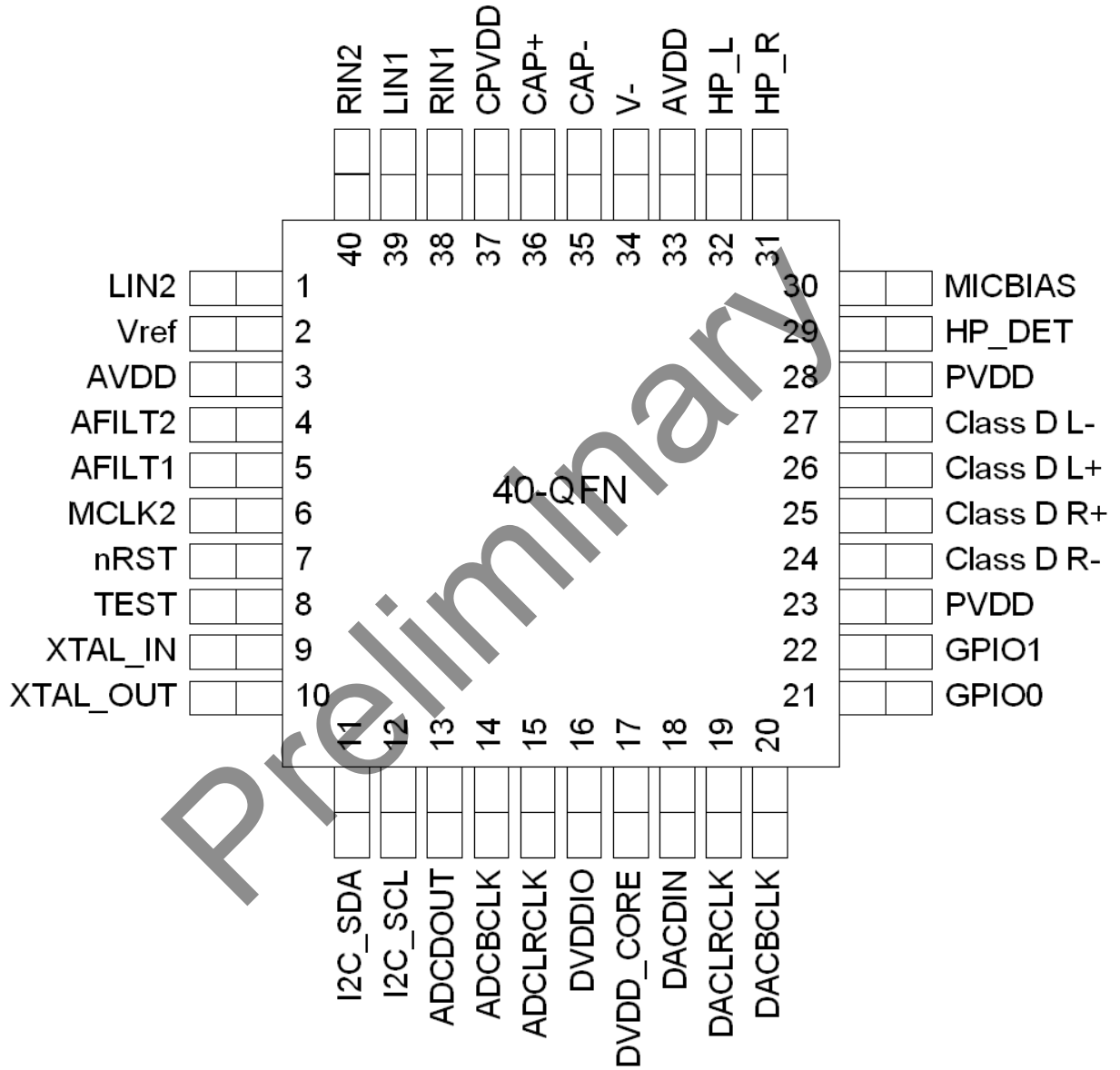

Figure 24. 40QFN Pin Assignment

10.4. Pin Tables

10.4.1. Power Pins

Pin Name	Pin Function	I/O	Internal Pull-up Pull-down	40 pin loc	48 pin loc
PVDD	BTL supply	I(Power)	None	23,28	27,34
PVSS	BTL supply	I(Power)	None	DAP	30, 31
DVDD_Core	DSP and other core logic+clocks	I(Power)	None	17	21
DVDDIO	Interface (I ² S, I ² C, GPIO)	I(Power)	None	16	19
DVSS	Digital return	I(Power)	None	DAP	20
AVDD	Analog core supply	I(Power)	None	3,33	4,39
AVSS	Analog return	I(Power)	None	DAP	3, 40
CPVDD	Charge pump supply	I(Power)	None	37	45
CAP+	Flying cap	I/O(Power)	None	36	44
CAP-	Flying cap	I/O(Power)	None	35	42
V-	Negative Analog supply (Bypass cap)	O(Power)	None	34	41
CPGND	Charge pump group	I(Power)	None	DAP	43

Table 13. Power Pins

Total Pins: 16

10.4.2. Reference Pins

Pin Name	Pin Function	I/O	Internal Pull-up Pull-down	40 Pin loc	48 Pin loc
MICBIAS	2.5V 1.5 mA microphone bias	O(Analog)	None	30	36
AFILT1	ADC input filter cap	I(Analog)	None	5	6
AFILT2	ADC input filter cap	I(Analog)	None	4	5
Vref	VREF reference pin (bypass)	I(Analog)	None	2	2

Table 14. Reference Pins

Total Pins: 4

10.4.3. Analog Input Pins

Pin Name	Pin Function	I/O	Internal Pull-up Pull-down	40 Pin loc	48 Pin loc
LIN1	Left Input #1	I(Analog)	None	39	47
RIN1	Right Input #1	I(Analog)	None	38	46
LIN2	Left Input #2	I(Analog)	None	1	1
RIN2	Right Input #2	I(Analog)	None	40	48
LIN3 DMIC_CLK	Left Input #3 for ACS422A00 Digital Mic Clock for ACS422D00	I(Analog)	None	not available	8
RIN3 DMIC_DAT	Right Input #3 for ACS422A00 Digital Mic Data for ACS422D00	I(Analog)	None	not available	7

Table 15. Analog Input Pins

Total Pins: 6

10.4.4. Analog Output Pins

Pin Name	Pin Function	I/O	Internal Pull-up Pull-down	40 Pin loc	48 Pin loc
HP_L	Headphone output	O(Analog)	None	32	38
HP_R	Headphone output	O(Analog)	None	31	37
Class D L+	BTL Left positive output	O(Analog)	None	26	32
Class D L-	BTL Left negative output	O(Analog)	None	27	33
Class D R+	BTL Right positive output	O(Analog)	None	25	29
Class D R-	BTL Right negative output	O(Analog)	None	24	28

Table 16. Analog Output Pins

Total Pins: 6

10.4.5. Data and Control Pins

Pin Name	Pin Function	I/O	Internal Pull-up Pull-down	40 Pin loc	48 Pin loc
GPIO1	General purpose I/O	I/O	none	22	26
GPIO0	General purpose I/O	I/O	none	21	25
nRST	Reset	I(Digital)	none	7	10
ADCBCLK	ADC I ² S shift clock	I/O(Digital)	Pull-Down	14	17
ADCLRCLK	ADC I ² S framing clock	I/O(Digital)	Pull-Down	15	18
ADCDOUT	ADC I ² S output data	O(Digital)	Pull-Down	13	16
DACBCLK	DAC I ² S shift clock	I/O(Digital)	Pull-Down	20	24
DACLRCLK	DAC I ² S framing clock	I/O(Digital)	Pull-Down	19	23
DACDIN	DAC I ² S input data	I(Digital)	Pull-Down	18	22
I2C_SCL	SCL I ² C shift clock	I(Digital)	Pull-Up	12	15
I2C_SDA	SDA I ² C shift data	I(Digital)	Pull-Up	11	14
HP_DET	Headphone jack detection	I(Digital)	Pull-Up	29	35
TEST	Reserved test pin	I(Analog)	None	8	11

Table 17. Data and Control Pins

Total Pins: 13

10.4.6. PLL Pins

Pin Name	Pin Function	I/O	Internal Pull-up Pull-down	40 Pin loc	48 Pin loc
XTAL_IN/MCLK1	Crystal input/MASTER CLK	I(XTAL)	None	9	12
XTAL_OUT	Crystal output	O(XTAL)	None	10	13
MCLK2	MASTER CLK	I(CLK)	NONE	6	9

Table 18. PLL Pins

Total Pins: 3

11. PACKAGE DRAWINGS

11.1. 48QFN Package Outline and Package Dimensions

Package dimensions are kept current with JEDEC Publication No. 95

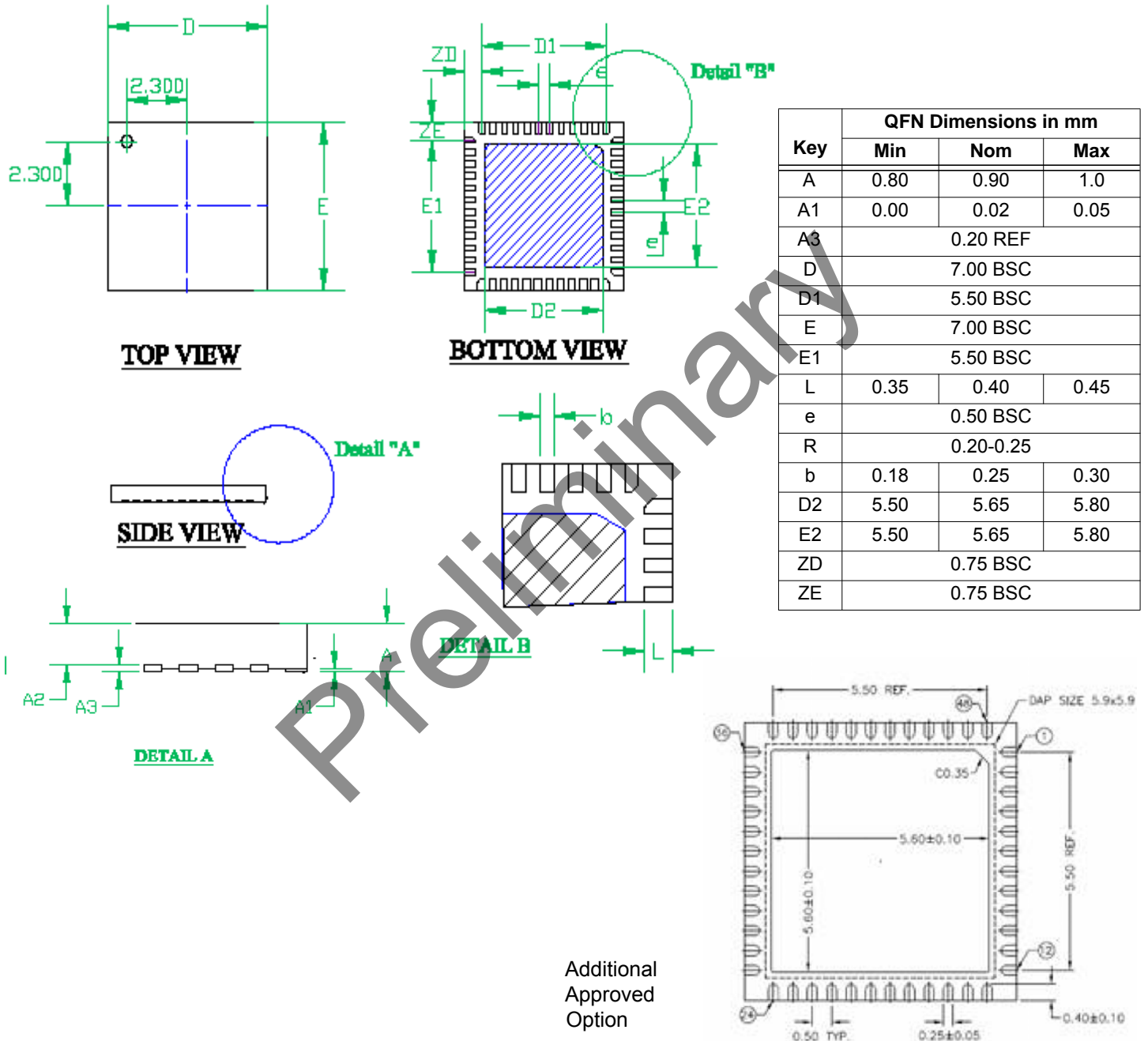

Figure 25. 48QFN Package Diagram

11.2. 40QFN Package Outline and Package Dimensions

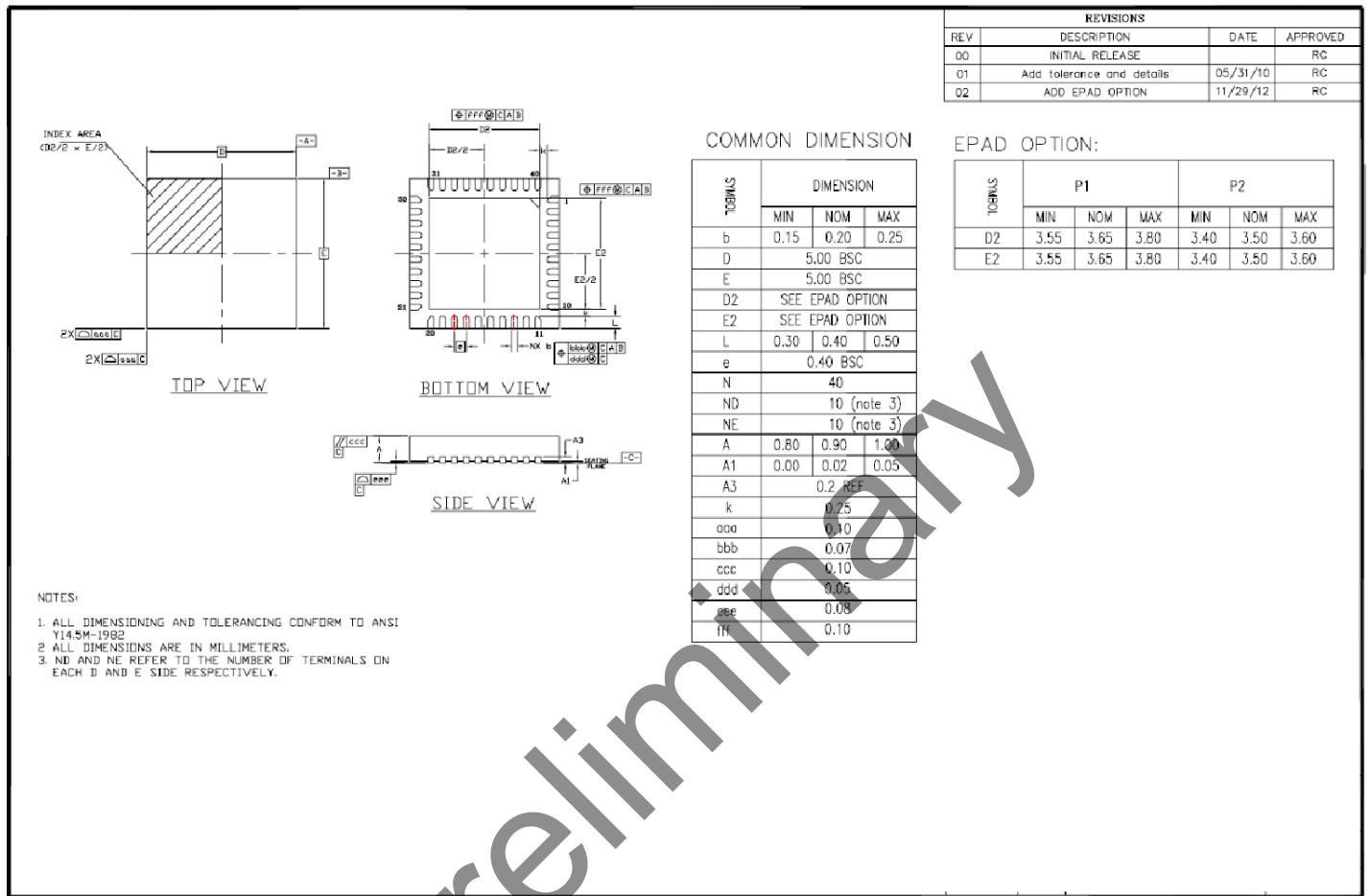

Figure 26. 40QFN Package Diagram

11.3. Pb Free Process- Package Classification Reflow Temperatures

Package Thickness	Volume mm ³ <350	Volume mm ³ 350 - 2000	Volume mm ³ >2000
<1.6mm	260 + 0 °C*	260 + 0 °C*	260 + 0 °C*
1.6mm - 2.5mm	260 + 0 °C*	250 + 0 °C*	245 + 0 °C*
> or = 2.5mm	250 + 0 °C*	245 + 0 °C*	245 + 0 °C*

*Tolerance: The device manufacturer/supplier shall assure process compatibility up to and including the stated classification temperature (this means Peak reflow temperature +0 °C. For example 260 °C+0 °C) at the rated MSL level.

Table 19. Reflow Temperatures

Note: TSI's package thicknesses are <2.5mm and <350 mm³, so 260 applies in every case.

TSCS42XX

Portable Consumer CODECs

12. APPLICATION INFORMATION

For application information, please see reference designs and application notes available on www.temposemi.com.

13. ORDERING INFORMATION

TSCS4221X1NLGXZAX	Analog Microphone in 48 QFN package Samples only
TSCS42A1X1NLGXZAX	Analog Microphone in 48 QFN package
TSCS42A2X1NLGXZAX	Digital Microphone in 48 QFN package
TSCS42A3X1NLGXZAX	Analog Microphone in 40 QFN package

Please contact an TSI Sales Representative with your clock requirements for factory programming. This programming will determine the orderable part number for the TSC42XX.

14. DISCLAIMER

While the information presented herein has been checked for both accuracy and reliability, manufacturer assumes no responsibility for either its use or for the infringement of any patents or other rights of third parties, which would result from its use. No other circuits, patents, or licenses are implied. This product is intended for use in normal commercial applications. Any other applications, such as those requiring extended temperature range, high reliability, or other extraordinary environmental requirements, are not recommended without additional processing by manufacturer. Manufacturer reserves the right to change any circuitry or specifications without notice. Manufacturer does not authorize or warrant any product for use in life support devices or critical medical instruments

15. DOCUMENT REVISION HISTORY

Revision	Date	Description of Change
0.5	May 2010	Initial release
0.8	July 2015	updated Register set, I2S Section and Block diagram.
0.9	September 2015	Updated Register

Preliminary



www.temposemi.com
8627 N. MoPac Expwy Suite 130
Austin, Texas 78759

DISCLAIMER Tempo Semiconductor, Inc. (TSI) and its subsidiaries reserve the right to modify the products and/or specifications described herein at any time and at TSI's sole discretion. All information in this document, including descriptions of product features and performance, is subject to change without notice. Performance specifications and the operating parameters of the described products are determined in the independent state and are not guaranteed to perform the same way when installed in customer products. The information contained herein is provided without representation or warranty of any kind, whether express or implied, including, but not limited to, the suitability of TSI's products for any particular purpose, an implied warranty of merchantability, or non-infringement of the intellectual property rights of others. This document is presented only as a guide and does not convey any license under intellectual property rights of TSI or any third parties.

TSI's products are not intended for use in life support systems or similar devices where the failure or malfunction of an TSI product can be reasonably expected to significantly affect the health or safety of users. Anyone using an TSI product in such a manner does so at their own risk, absent an express, written agreement by TSI.

Tempo Semiconductor, TSI and the TSI logo are registered trademarks of TSI. Other trademarks and service marks used herein, including protected names, logos and designs, are the property of TSI or their respective third party owners.