

**FEATURES**

- InGaP HBT Technology
- High Efficiency:
  - 39 % @ P<sub>OUT</sub> = +28.7 dBm
  - 22 % @ P<sub>OUT</sub> = +16.6 dBm
  - 9 % @ P<sub>OUT</sub> = +8 dBm
- Low Quiescent Current: 4.5 mA
- Internal Voltage Regulation
- Built-in Directional Coupler
- Common V<sub>MODE</sub> Control Line
- Simplified V<sub>CC</sub> Bus PCB routing
- Reduced External Component Count
- Low Profile Surface Mount Package: 1 mm
- RoHS Compliant Package, 260 °C MSL-3

**APPLICATIONS**

- Cell & PCS Dual-band Wireless Handsets and Data Devices for HSDPA/HSPA networks.

**PRODUCT DESCRIPTION**

AWU6615 addresses the demand for increased integration in dual-band handsets for WCDMA networks. The small footprint 3 mm x 5 mm x 1 mm surface-mount RoHS compliant package contains independent RF PA paths to ensure optimal performance in both frequency bands, while achieving a 25% PCB space savings compared with solutions requiring two single-band PAs. The package pinout was chosen to enable handset manufacturers to easily route bias to both power amplifiers and simplify control with common mode pins. The device is manufactured on an advanced InGaP HBT MMIC technology offering state-of-the-art reliability, temperature stability, and ruggedness. The AWU6615 is part of ANADIGICS' High-Efficiency-at-Low-Power (HELP™) family of WCDMA power amplifiers, which deliver low quiescent currents and significantly greater efficiency without the need of an external DC-DC converter. Through selectable bias modes, the AWU6615 achieves optimal efficiency, specifically at low- and mid-range power levels where the PA typically operates, thereby dramatically increasing handset talk-time. Its built-in voltage regulator eliminates the need for external

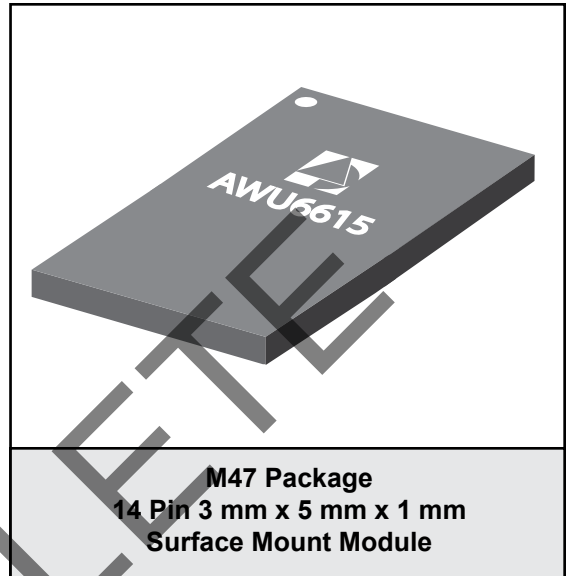

switches. This PA has built-in directional couplers for each band, with a common coupler output port CPL\_OUT. These couplers provide high directivity and 23 dB Coupling. The 3 mm x 5 mm x 1 mm surface mount package incorporates matching networks optimized for output power, efficiency and linearity in a 50 Ω system.

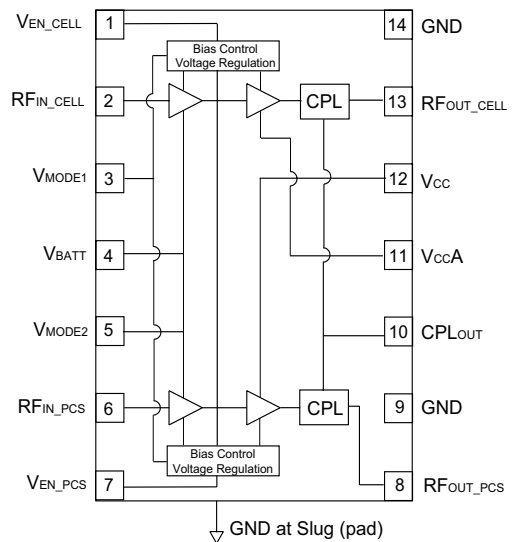

**Figure 1: Block Diagram**

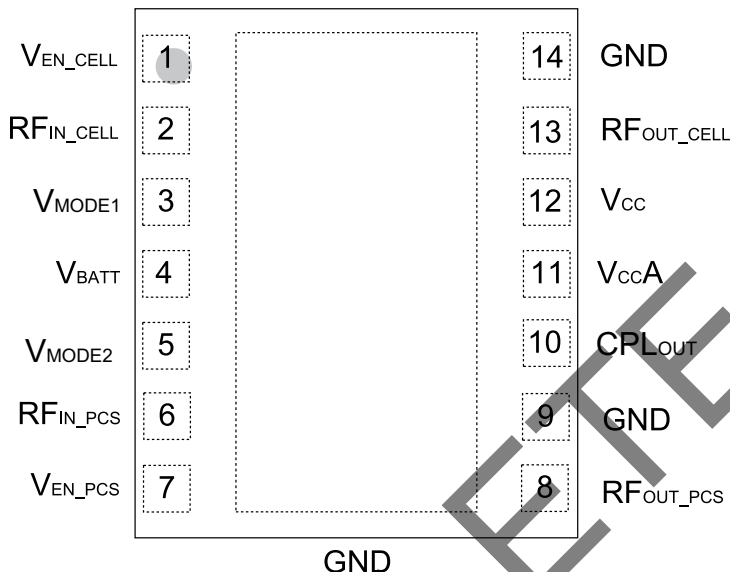

GND  
**Figure 2: Pinout**

**Table 1: Pin Description**

PIN	NAME	DESCRIPTION
1	V <sub>EN_CELL</sub>	Enable Voltage for Cell Band
2	RF <sub>IN_CELL</sub>	RF Input for Cell Band
3	V <sub>MODE1</sub>	Mode Control Voltage for Cell and PCS Bands
4	V <sub>BATT</sub>	Battery Voltage
5	V <sub>MODE2</sub>	Mode Control Voltage for Cell
6	RF <sub>IN_PCS</sub>	RF Input for PCS Band
7	V <sub>EN_PCS</sub>	Enable Voltage for PCS Band
8	RF <sub>OUT_PCS</sub>	RF Output for PCS Band
9	GND	Ground
10	CPL <sub>OUT</sub>	Coupler Output Port
11	V <sub>ccA</sub>	Battery Voltage A
12	V <sub>cc</sub>	Supply Voltage
13	RF <sub>OUT_CELL</sub>	RF Output for Cell Band
14	GND	Ground

## ELECTRICAL CHARACTERISTICS

Table 2: Absolute Minimum and Maximum Ratings

PARAMETER	MIN	MAX	UNIT
Supply Voltage ( $V_{BATT}$ , $V_{CC}$ , $V_{CCA}$ )	0	+5	V
Mode Control Voltage ( $V_{MODE1}$ , $V_{MODE2}$ )	0	+3.5	V
Enable Voltage ( $V_{EN\_CELL}$ , $V_{EN\_PCS}$ )	0	+3.5	V
RF Input Power (PIN)	-	+10	dBm
Storage Temperature ( $T_{STG}$ )	-40	+150	°C

Stresses in excess of the absolute ratings may cause permanent damage. Functional operation is not implied under these conditions. Exposure to absolute ratings for extended periods of time may adversely affect reliability.

Table 3: Operating Ranges

PARAMETER	MIN	TYP	MAX	UNIT	COMMENTS
Operating Frequency (f)	824 1850	-	849 1910	MHz	Cellular (Band 5) PCS (Band 2)
Supply Voltage ( $V_{CC}$ and $V_{BATT}$ )	+3.2	+3.4	+4.2	V	
Enable Voltage ( $V_{EN}$ )	+1.35 0	+1.8 -	+3.1 +0.5	V	PA "on" PA "shut down"
Mode Control Voltage ( $V_{MODE0}$ , $V_{MODE1}$ )	+1.35 0	+1.8 -	+3.1 +0.5	V	Low Bias Mode High Bias Mode
RF Output Power, Band 5, UMTS R99 WCDMA, HPM HSPA (MPR = 0 dB), HPM R99 WCDMA, MPM HSPA (MPR = 0 dB), MPM R99 WCDMA, LPM HSPA (MPR = 0 dB), LPM	28.2 <sup>(1)</sup> 27.2 <sup>(1)</sup> 16.1 <sup>(1)</sup> 15.1 <sup>(1)</sup> 7.5 <sup>(1)</sup> 6.5 <sup>(1)</sup>	28.7 27.7 16.6 15.6 8.0 7.0	- - - - - -	dBm	3GPP TS 34.121-1, REL8 Table C.11.1.3, Subtest 1
RF Output Power, Band 2, UMTS R99 WCDMA, HPM HSPA (MPR = 0 dB), HPM R99 WCDMA, MPM HSPA (MPR = 0 dB), MPM R99 WCDMA, LPM HSPA (MPR = 0 dB), LPM	28.3 <sup>(1)</sup> 27.3 <sup>(1)</sup> 16.5 <sup>(1)</sup> 15.5 <sup>(1)</sup> 8.0 <sup>(1)</sup> 7.0 <sup>(1)</sup>	28.8 27.8 17.0 16.0 8.5 7.5	- - - - - -	dBm	3GPP TS 34.121-1, REL8 Table C.11.1.3, Subtest 1
Case Temperature ( $T_C$ )	-30	-	+90	°C	

The device may be operated safely over these conditions; however, parametric performance is guaranteed only over the conditions defined in the electrical specifications.

Notes:

(1) For operation at  $V_{CC} = +3.2$  V,  $T_C = +90$  °C  $P_{OUT}$  is derated by 0.5 dB.

**Table 4: Electrical Specifications - Cellular Band (Band 5)**  
 (T<sub>C</sub> = +25 °C, V<sub>BATT</sub> = V<sub>CC</sub> = +3.4 V, V<sub>EN\_CELL</sub> = +1.8 V, 50 Ω system, R99 uplink waveform)

PARAMETER	MIN	TYP	MAX	UNIT	COMMENTS		
					P <sub>OUT</sub>	V <sub>MODE1</sub>	V <sub>MODE2</sub>
Gain	25.5 14.5 9	27.5 17 11.5	30 20 14	dB	+28.7 dBm +16.6 dBm +8 dBm	0 V 1.8 V 1.8 V	0 V 0 V 1.8 V
ACLR1 @ 5 MHz Offset <sup>(1)</sup>	- - -	-42 -42 -41	-37 -37 -37	dBc	+28.7 dBm +16.6 dBm +8 dBm	0 V 1.8 V 1.8 V	0 V 0 V 1.8 V
ACLR2 @ 10 MHz Offset <sup>(1)</sup>	- - -	-58 -55 -54	-48 -48 -48	dBc	+28.7 dBm +16.6 dBm +8 dBm	0 V 1.8 V 1.8 V	0 V 0 V 1.8 V
Power-Added Efficiency <sup>(1)</sup>	35 18 6	39 22 9	- - -	%	+28.7 dBm +16.6 dBm +8 dBm	0 V 1.8 V 1.8 V	0 V 0 V 1.8 V
Quiescent Current (I <sub>q</sub> )	-	4	6	mA	through V <sub>CC</sub> pin, V <sub>MODE1</sub> = +1.8 V, V <sub>MODE2</sub> = +1.8 V		
Mode Control Current	-	0.1	0.15	mA	through V <sub>MODE</sub> pins, V <sub>MODE1</sub> = +1.8 V		
Battery Current	-	1.5	2.5	mA	through V <sub>BATT</sub> pin, V <sub>MODE1</sub> = +1.8 V, V <sub>MODE2</sub> = +1.8 V		
Enable Current	-	0.15	0.25	mA	through V <sub>EN_CELL</sub> pin, V <sub>MODE</sub> = 1.8 V		
Noise in Receive Band	-	-133	-	dBm/Hz	869 MHz to 894 MHz		
Harmonics 2fo 3fo, 4fo	- - -	-40 -50	-30 -38	dBc	P <sub>OUT</sub> < +28.7 dBm		
Input Impedance	-	-	2:1	VSWR			
Coupling Factor	-	23	-	dB			
Spurious Output Level (all spurious outputs)	-	-	-65	dBc	P <sub>OUT</sub> < +28.7 dBm In-band Load VSWR < 5:1 Out-of-band Load VSWR < 10:1 Applies over all operating conditions		
Load mismatch stress with no permanent degradation or failure	8:1	-	-	VSWR	Applies over full operating conditions		

Notes:

(1) Efficiency and ACLR measured at 836.5 MHz.

**Table 5: Electrical Specifications - PCS Band (Band 2)**  
 (T<sub>C</sub> = +25 °C, V<sub>BATT</sub> = V<sub>CC</sub> = +3.4 V, V<sub>EN\_PCS</sub> = +1.8 V, 50 Ω system, R99 uplink waveform)

PARAMETER	MIN	TYP	MAX	UNIT	COMMENTS		
					P <sub>OUT</sub>	V <sub>MODE1</sub>	V <sub>MODE2</sub>
Gain	25 12 8	27 15 11	30.5 18 13.5	dB	+28.8 dBm +17 dBm +8.5 dBm	0 V 1.8 V 1.8 V	0 V 0 V 1.8 V
ACLR1 @ 5 MHz Offset	- - -	-41 -40 -42	-37 -37 -37	dBc	+28.8 dBm +17 dBm +8.5 dBm	0 V 1.8 V 1.8 V	0 V 0 V 1.8 V
ACLR2 @ 5 MHz Offset	- - -	-52 -53 -56	-48 -48 -48	dBc	+28.8 dBm +17 dBm +8.5 dBm	0 V 1.8 V 1.8 V	0 V 0 V 1.8 V
Power-Added Efficiency <sup>(1)</sup>	35 18 6	39 21 8.5	- - -	%	+28.8 dBm +17 dBm +8.5 dBm	0 V 1.8 V 1.8 V	0 V 0 V 1.8 V
Quiescent Current (I <sub>cq</sub> )	-	5	7	mA	through V <sub>CC</sub> Pin, V <sub>MODE1</sub> = +1.8 V, V <sub>MODE2</sub> = +1.8 V		
Mode Control Current	-	0.1	0.15	mA	through V <sub>MODE</sub> pins, V <sub>MODE1</sub> = +1.8 V		
Battery Current	-	1.5	2.5	mA	through V <sub>BATT</sub> pin, V <sub>MODE1</sub> = +1.8 V, V <sub>MODE2</sub> = +1.8 V		
Enable Current	-	0.15	0.25	mA	through V <sub>EN_CELL</sub> pin, V <sub>MODE1</sub> = V <sub>MODE2</sub> = 1.8 V		
HBT Leakage Current (V <sub>CC</sub> )	-	<1	5	μA	V <sub>BATT</sub> = +4.2 V, V <sub>CC</sub> = +4.2 V, V <sub>EN_CELL</sub> = 0 V, V <sub>MODE1</sub> = 0 V, V <sub>MODE2</sub> = 0 V		
Total Decoder Current on V <sub>BATT</sub> (Shutdown Mode)	-	12	22	μA	V <sub>BATT</sub> = +4.2 V, V <sub>CC</sub> = +4.2 V, V <sub>EN</sub> = 0 V, V <sub>MODE1</sub> = V <sub>MODE2</sub> = 0 V		
Noise in Receive Band	-	-134	-	dBm/Hz	1930 MHz to 1990 MHz		
Harmonics 2fo 3fo, 4fo	- - -	-42 -50	-30 -38	dBc	P <sub>OUT</sub> < +28.8 dBm		
Input Impedance	-	-	2:1	VSWR			
Coupling Factor	-	22.5	-	dB			
Spurious Output Level (all spurious outputs)	-	-	-65	dBc	P <sub>OUT</sub> < +28.8 dBm In-band Load VSWR < 5:1 Out-of-band Load VSWR < 10:1 Applies over all operating conditions		
Load mismatch stress with no permanent degradation or failure	8:1	-	-	VSWR	Applies over full operating conditions		

## Notes:

1. Efficiency and ACLR measured at 1880 MHz.

**APPLICATION INFORMATION**

To ensure proper performance, refer to all related Application Notes on the ANADIGICS web site: <http://www.anadigics.com>

**Shutdown Mode**

The power amplifier may be placed in a shutdown mode by applying logic low levels (see Operating Ranges table) to the  $V_{ENABLE}$  voltage.

**Bias Modes, Medium Bias Mode**

The power amplifier may be placed in Low Bias mode or a High Bias mode by applying the appropriate logic level (see Operating Ranges table) to the  $V_{MODE1}$  and  $V_{MODE2}$  pins. The Bias Control table lists the recommended modes of operation for various applications.

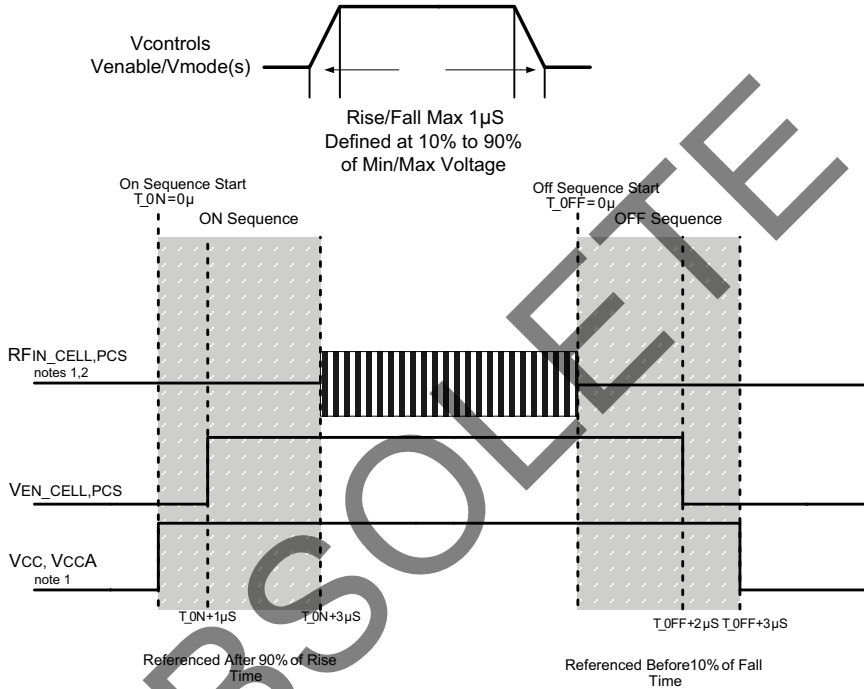

**Figure 3: Minimum Recommended ON/OFF Timing Sequence**

Notes:

- (1) Level might be changed after RF is ON.
- (2) RF OFF defined as  $P_{IN} \leq -30$  dBm.
- (3) Switching simultaneously between  $V_{MODE}$  and  $V_{EN}$  is not recommended.

**Table 6: Bias Control**

APPLICATION	P <sub>OUT</sub> LEVELS	BIAS MODE	V <sub>EN</sub>	V <sub>MODE1</sub>	V <sub>MODE2</sub>	V <sub>CC</sub>	V <sub>BATT</sub>
WCDMA - low power (Low Bias Mode)	< +8 dBm	Low	+1.8 V	+1.8	+1.8 V	3.2 - 4.2 V	> 3.2 V
WCDMA - med power (Medium Bias Mode)	> +8 dBm < +16.5 dBm	Low	+1.8 V	+1.8 V	0 V	3.2 - 4.2 V	> 3.2 V
WCDMA - high power (High Bias Mode)	> +16.5 dBm	High	+1.8 V	0 V	0 V	3.2 - 4.2 V	> 3.2 V
Shutdown	-	Shutdown	0 V	-	-	3.2 - 4.2 V	> 3.2 V

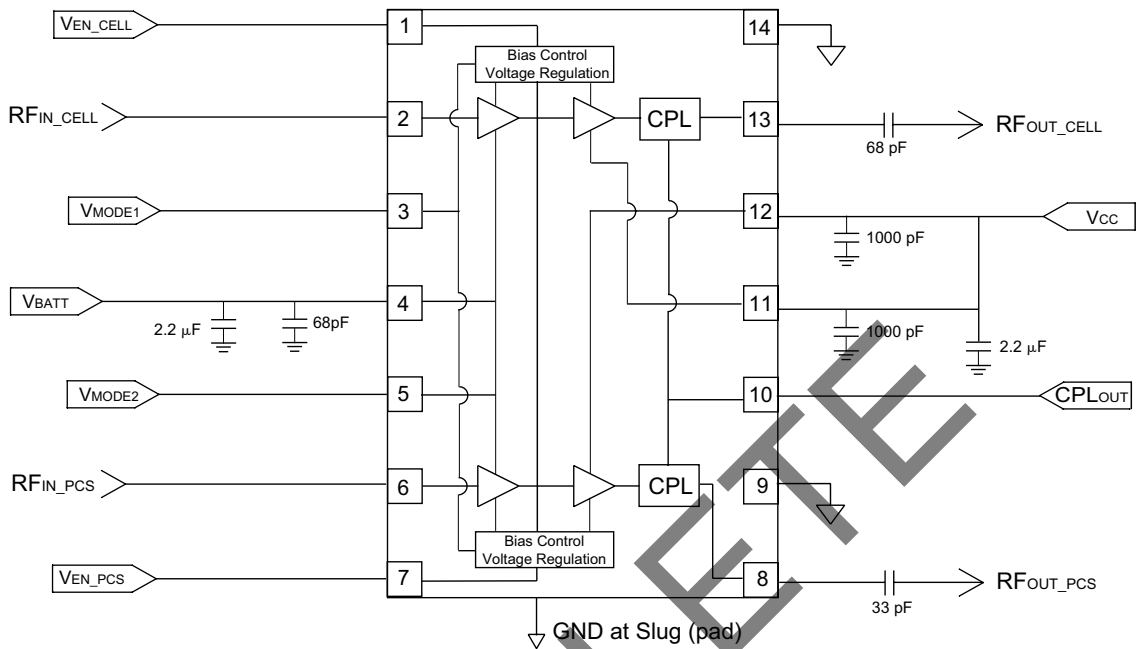
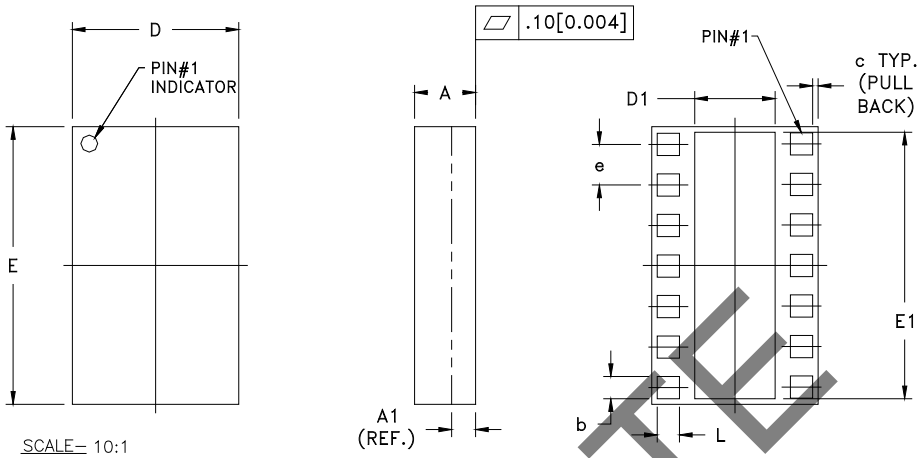

Figure 4: Application Circuit

OBSOLETE

PACKAGE OUTLINE



SCALE= 10:1

SYMBOL	MILLIMETERS			INCHES			NOTE
	MIN.	NOM.	MAX.	MIN.	NOM.	MAX.	
A	0.91	1.03	1.13	0.035	0.041	0.044	—
A1	PLEASE REFER TO LAMINATE CONTROL DRAWING						—
b	0.32	0.37	0.41	0.013	0.015	0.016	3
c	—	0.10	—	—	0.004	—	—
D	2.88	3.00	3.12	0.113	0.118	0.123	—
D1	1.45	1.50	1.57	0.057	0.059	0.062	3
E	4.88	5.00	5.12	0.192	0.197	0.202	—
E1	4.70	4.75	4.80	0.185	0.187	0.189	3
e	—	0.73	—	—	0.029	—	4
L	0.32	0.37	0.41	0.013	0.015	0.016	3

NOTES:

1. CONTROLLING DIMENSIONS: MILLIMETERS
2. UNLESS SPECIFIED TOLERANCE=±0.076[0.003].
3. PADS (INCLUDING CENTER) SHOWN UNIFORM SIZE FOR REFERENCE ONLY. ACTUAL PAD SIZE AND LOCATION WILL VARY WITHIN MIN. AND MAX. DIMENSIONS ACCORDING TO SPECIFIC LAMINATE DESIGN.
4. PITCH MEASUREMENT (e) TAKEN CENTERLINE TO CENTERLINE OF SOLDER MASK OPENINGS.
5. UNLESS SPECIFIED DIMENSIONS ARE SYMMETRICAL ABOUT CENTER LINES SHOWN.

Figure 5: Package Outline - 14 Pin 3 mm x 5 mm x 1 mm Surface Mount Module

TOP BRAND

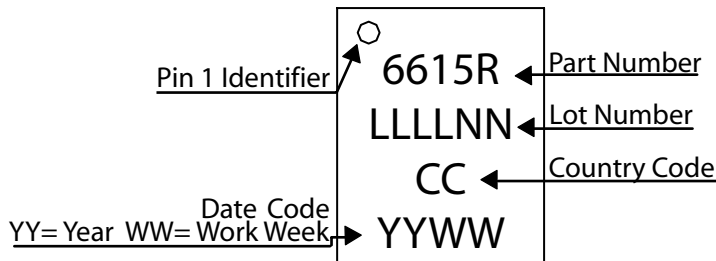

Figure 6: Branding Specification

## ORDERING INFORMATION

ORDER NUMBER	TEMPERATURE RANGE	PACKAGE DESCRIPTION	COMPONENT PACKAGING
AWU6615RM47Q7	-30 °C to +90 °C	RoHS Compliant 14 Pin 3 mm x 5 mm x 1 mm Surface Mount Module	Tape and Reel, 2500 pieces per Reel
AWU6615RM47P9	-30 °C to +90 °C	RoHS Compliant 14 Pin 3 mm x 5 mm x 1 mm Surface Mount Module	Partial Tape and Reel

**ANADIGICS**

141 Mount Bethel Road  
Warren, New Jersey 07059, U.S.A.  
Tel: +1 (908) 668-5000  
Fax: +1 (908) 668-5132

URL: <http://www.anadigics.com>

**IMPORTANT NOTICE**

ANADIGICS, Inc. reserves the right to make changes to its products or to discontinue any product at any time without notice. The product specifications contained in Advanced Product Information sheets and Preliminary Data Sheets are subject to change prior to a product's formal introduction. Information in Data Sheets have been carefully checked and are assumed to be reliable; however, ANADIGICS assumes no responsibilities for inaccuracies. ANADIGICS strongly urges customers to verify that the information they are using is current before placing orders.

**WARNING**

ANADIGICS products are not intended for use in life support appliances, devices or systems. Use of an ANADIGICS product in any such application without written consent is prohibited.