

TOSHIBA CMOS DIGITAL INTEGRATED CIRCUIT SILICON MONOLITHIC

TC9290P, TC9290F

KEY SCAN IC

TC9290P, TC9290F is detected key input and transmitted serial data to controller which is suited for extension of DTS or MPU.

Especially, this IC is available for "KEY DETACHABLE SECURITY SYSTEM" of car audio.

FEATURES

- Wide range of operation supply voltage and low static current.
 - : $V_{DD} = 3.0 \sim 5.5V$
 - : $I_{DQ} \leq 5.0 \mu A$ (at stand-by mode)
- Communicate with controller by one bus lines. (D_{OUT} of Pin19)
- 32functions are basically available. Up to 112commands (28×4=112) can be output by double pushing.
- Serial data can be changed the remote control code (Format of TC9243P, TC9243F) and the key data code (Omission code) methods.
- Packages in two types : DIP and FLAT types are available.
 - DIP20 : TC9290P
 - SOP20 : TC9290F

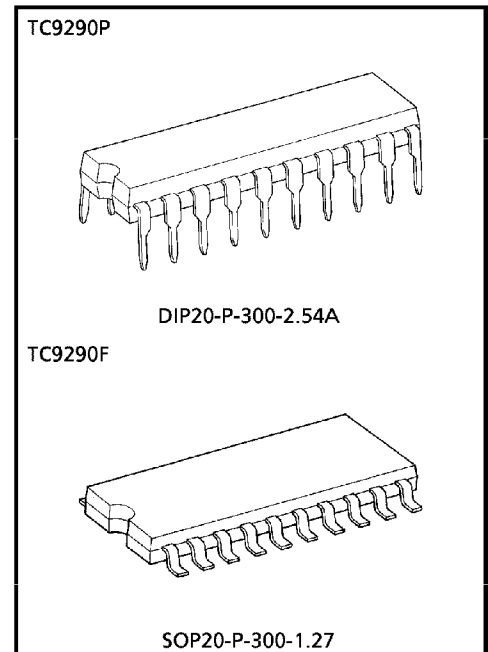

Weight
 DIP20-P-300-2.54A : 1.4g (Typ.)
 SOP20-P-300-1.27 : 0.48g (Typ.)

PIN CONNECTION (TOP VIEW)

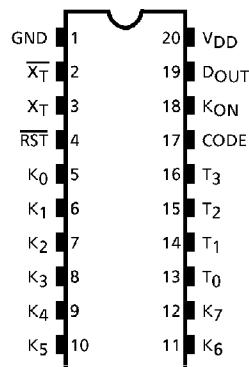

980910EBA2

- TOSHIBA is continually working to improve the quality and the reliability of its products. Nevertheless, semiconductor devices in general can malfunction or fail due to their inherent electrical sensitivity and vulnerability to physical stress. It is the responsibility of the buyer, when utilizing TOSHIBA products, to observe standards of safety, and to avoid situations in which a malfunction or failure of a TOSHIBA product could cause loss of human life, bodily injury or damage to property. In developing your designs, please ensure that TOSHIBA products are used within specified operating ranges as set forth in the most recent products specifications. Also, please keep in mind the precautions and conditions set forth in the TOSHIBA Semiconductor Reliability Handbook.
- The products described in this document are subject to the foreign exchange and foreign trade laws.
- The information contained herein is presented only as a guide for the applications of our products. No responsibility is assumed by TOSHIBA CORPORATION for any infringements of intellectual property or other rights of the third parties which may result from its use. No license is granted by implication or otherwise under any intellectual property or other rights of TOSHIBA CORPORATION or others.
- The information contained herein is subject to change without notice.

BLOCK DIAGRAM

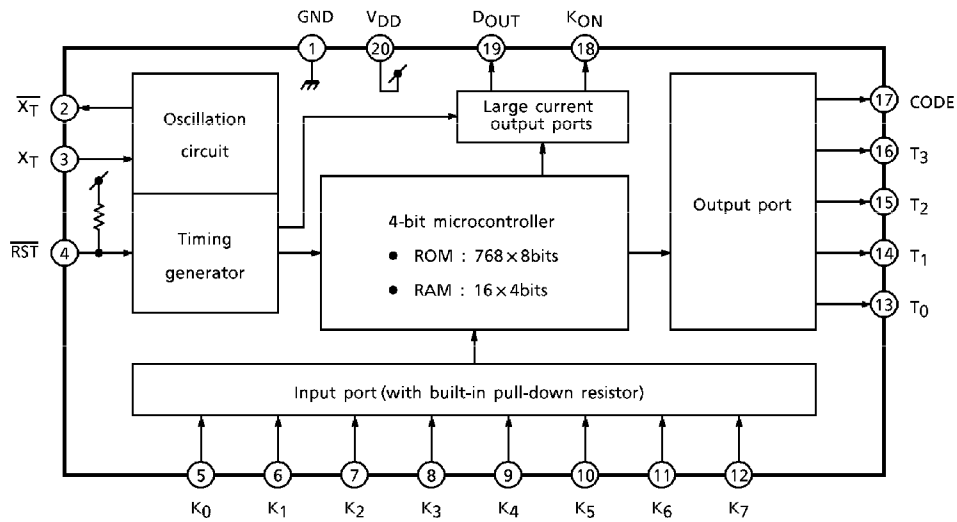

TERMINAL FUNCTION

PIN No.	SYMBOL	PIN NAME	FUNCTION & OPERATION
1	GND	Power Terminal	Applies supply voltage. ($V_{DD} = 3.0 \sim 5.5V$)
20	V_{DD}		
2	$\overline{X_T}$	Oscillation Terminal	Input/output terminals for the ceramic oscillators, with built-in amplifier circuit and feedback resistor.
3	X_T		
4	\overline{RST}	Reset Input	When this pin is set at "L" level, the inside is initialized. With a built-in pull-up resistor.
5~12	$K_0 \sim K_7$	Key Inputs	The input terminals for key matrix. Each of all the pins has a built-in pull-down resistor.
13~16	$T_0 \sim T_3$	Key Scan Output	The key matrix scan output terminals. C-MOS output.
17	CODE	Code Scan Output	The terminal for selected remote control code and key data code mode. At the remote control code mode, this terminal is output system code scan signal. P-ch open drain output.
18	K_{ON}	Key Input Detector Output	This terminal is output "L" level when the key is input. CMOS output.
19	DOUT	Serial Data Output	Serial data output terminal. ("H" level output) CMOS output.

DESCRIPTION OF OPERATION

1. OUTPUT MODE OF REMOTE CONTROL CODE

The TC9290P, TC9290F enables the setting of maximum 32keys in combination of K₀~K₇ and T₀~T₃ keys when code output terminal of pin17 connect to key input terminal of pin12 by the diode jumper.

Further, system codes are stable in combination of K₀~K₆ and code keys by the diode jumper.

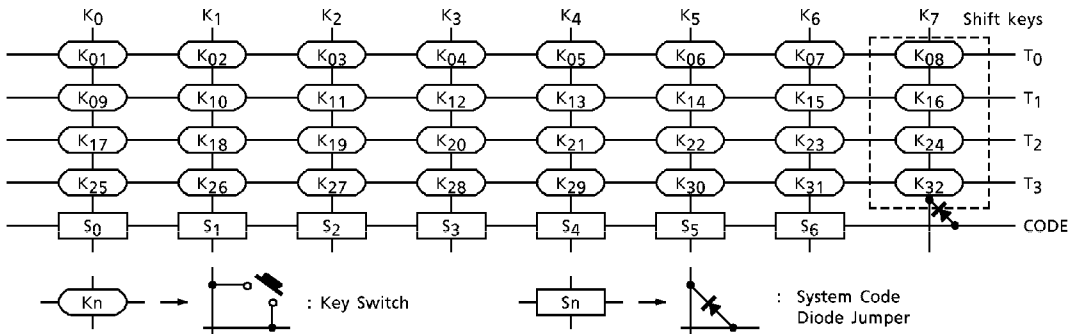

- K₀₈, 16, 24 and 32 (the shift key) keys can be pushed simultaneously with other keys (the normal keys). However, the simultaneous keying of the shift keys and that of the normal keys are prohibited.
- The system code setting is made by the diode jumper between "CODE" key and "K₀~K₆" keys. With the diode jumper, data code will become "L". Further, "S₇" code is fixed at "1" and cannot be changed.
- Data format (32bit data)

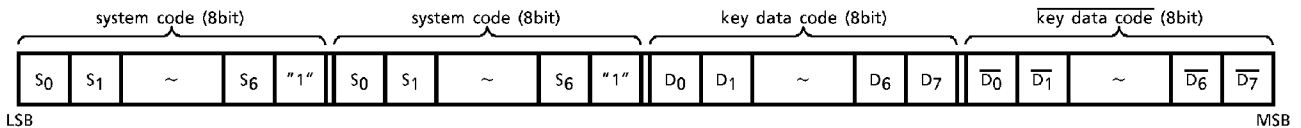

NOTE : At the remote control code mode, data format is same as TC9243P, TC9243F of infrared remote control signal transmission IC. However, it does not include modulation by 38kHz of carrier frequency.

2. OUTPUT MODE OF KEY DATA CODE

When code output terminal of pin17 is set at open, it will become key data code (commission mode).

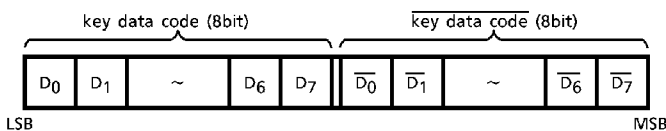

3. KEY DATA CODE

Key No.	Tn	Kn	D0	D1	D2	D3	D4	D5	D6	D7
K01	T0	K0	1	0	0	0	0	○ Shift key data ○ "000" except dual keying		
K02		K1	0	1	0	0	0			
K03		K2	1	1	0	0	0			
K04		K3	0	0	1	0	0			
K05		K4	1	0	1	0	0			
K06		K5	0	1	1	0	0			
K07		K6	1	1	1	0	0			
K08		K7	○ Normal key data ○ "00000" except dual keying							
K09	T1	K0	1	0	0	1	0	○ Shift key data ○ "000" except dual keying		
K10		K1	0	1	0	1	0			
K11		K2	1	1	0	1	0			
K12		K3	0	0	1	1	0			
K13		K4	1	0	1	1	0			
K14		K5	0	1	1	1	0			
K15		K6	1	1	1	1	0			
K16		K7	○ Normal key data ○ "00000" except dual keying							
K17	T2	K0	1	0	0	0	1	○ Shift key data ○ "000" except dual keying		
K18		K1	0	1	0	0	1			
K19		K2	1	1	0	0	1			
K20		K3	0	0	1	0	1			
K21		K4	1	0	1	0	1			
K22		K5	0	1	1	0	1			
K23		K6	1	1	1	0	1			
K24		K7	○ Normal key data ○ "00000" except dual keying							
K25	T3	K0	1	0	0	1	1	○ Shift key data ○ "000" except dual keying		
K26		K1	0	1	0	1	1			
K27		K2	1	1	0	1	1			
K28		K3	0	0	1	1	1			
K29		K4	1	0	1	1	1			
K30		K5	0	1	1	1	1			
K31		K6	1	1	1	1	1			
K32		K7	○ Normal key data ○ "00000" except dual keying							

Normal key : K01~K07, K09~K15, K17~K23, K25~K31
 Shift key : K08, K16, K24, K32

4. SERIAL DATA (TX_{out}) OUTPUT WAVEFORM (T_m = 5 / f_{OSC} : system clock)

(1) Remote Control Data Mode

Key ON (In case of f_{OSC} = 455kHz)

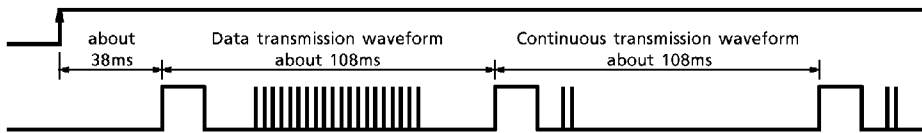

Data transmission waveform

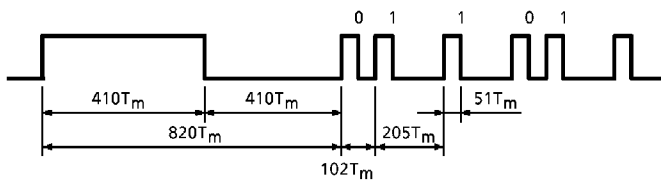
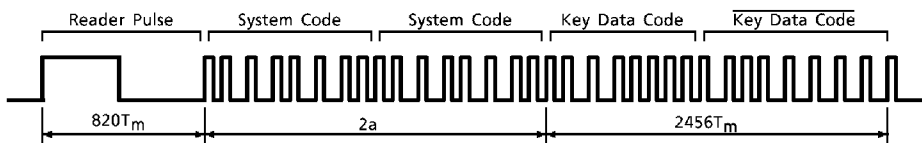

Continuous transmission waveform

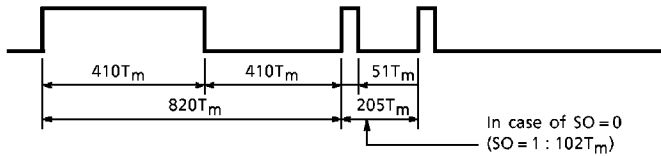

(2) Key Data Mode

Key ON (In case of f_{OSC} = 455kHz)

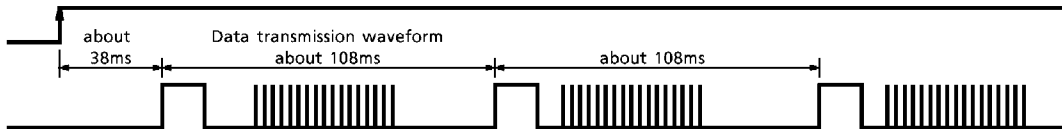

Data transmission waveform

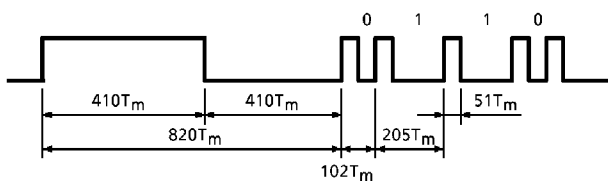
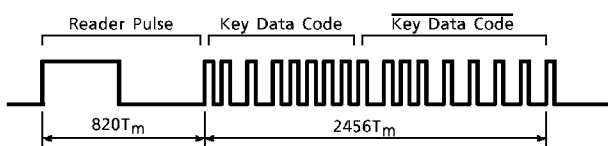

MAXIMUM RATINGS (Ta = 25°C)

CHARACTERISTIC	SYMBOL	RATING	UNIT
Supply Voltage	V _{DD}	- 0.3~6.0	V
Input Voltage	V _{IN}	V _{SS} - 0.3~V _{DD} + 0.3V	V
Output Current	I _{OUT}	- 20	mA
Power Dissipation	P _D	350 (300) *	mW
Operating Temperature	T _{opr}	- 40~85	°C
Storage Temperature	T _{stg}	- 65~150	°C

* : The value shown in parenthesis applies to the TC9290F.

ELECTRICAL CHARACTERISTICS

Recommended operating conditions

(Unless otherwise specified, V_{DD} = 5.0V, Ta = 25°C, For items with an asterisk (*), Ta = - 40~85°C)

CHARACTERISTIC	SYMBOL	TEST CIR-CUIT	TEST CONDITION	MIN.	TYP.	MAX.	UNIT
Operating Supply Voltage *	V _{DD}	—	—	3.0	5.0	5.5	V
Oscillation Frequency *	f _{OSC}	—	—	400	455	800	kHz
Input High Voltage	V _{IH}	—	(except \overline{RST})	V _{DD} × 0.7	—	V _{DD}	V
Input High Voltage	V _{IH}	—	(\overline{RST})	V _{DD} × 0.8	—	V _{DD}	V
Input Low Voltage	V _{IL}	—	(except \overline{RST})	0	—	V _{DD} × 0.3	V
Input Low Voltage	V _{IL}	—	(\overline{RST})	0	—	V _{DD} × 0.2	V

DC CHARACTERISTICS (Unless otherwise specified, V_{DD} = 5.0V, Ta = 25°C)

CHARACTERISTIC	SYMBOL	TEST CIR-CUIT	TEST CONDITION	MIN.	TYP.	MAX.	UNIT
Operating Supply Voltage	I _{DD}	—	f _{OSC} = 455kHz	—	0.5	1.2	mA
Static Supply Current	I _{QD}	—	Hold Mode	—	—	5.0	μA
Pull-Down Resistor	R _D	—	(K ₀ ~K ₇)	100	200	400	kΩ
Pull-Up Resistor	R _U	—	(\overline{RST})	25	50	100	kΩ
Output High Current	I _{OH}	—	(TX _{out}) V _{OH} = 1.5V	- 10	- 20	—	mA
Output Low Current	I _{OL}	—	(TX _{on}) V _{OL} = 1.5V	5	10	—	mA
Input Leak Current	I _{LI}	—	V _{IN} = V _{DD} , GND	- 1.0	—	1.0	μA

APPLICATION CIRCUIT

1. COMMONLY USE WITH INFRARED REMOTE CONTROL IC (TC9243P, TC9243F)

○ KEY DETACHABLE

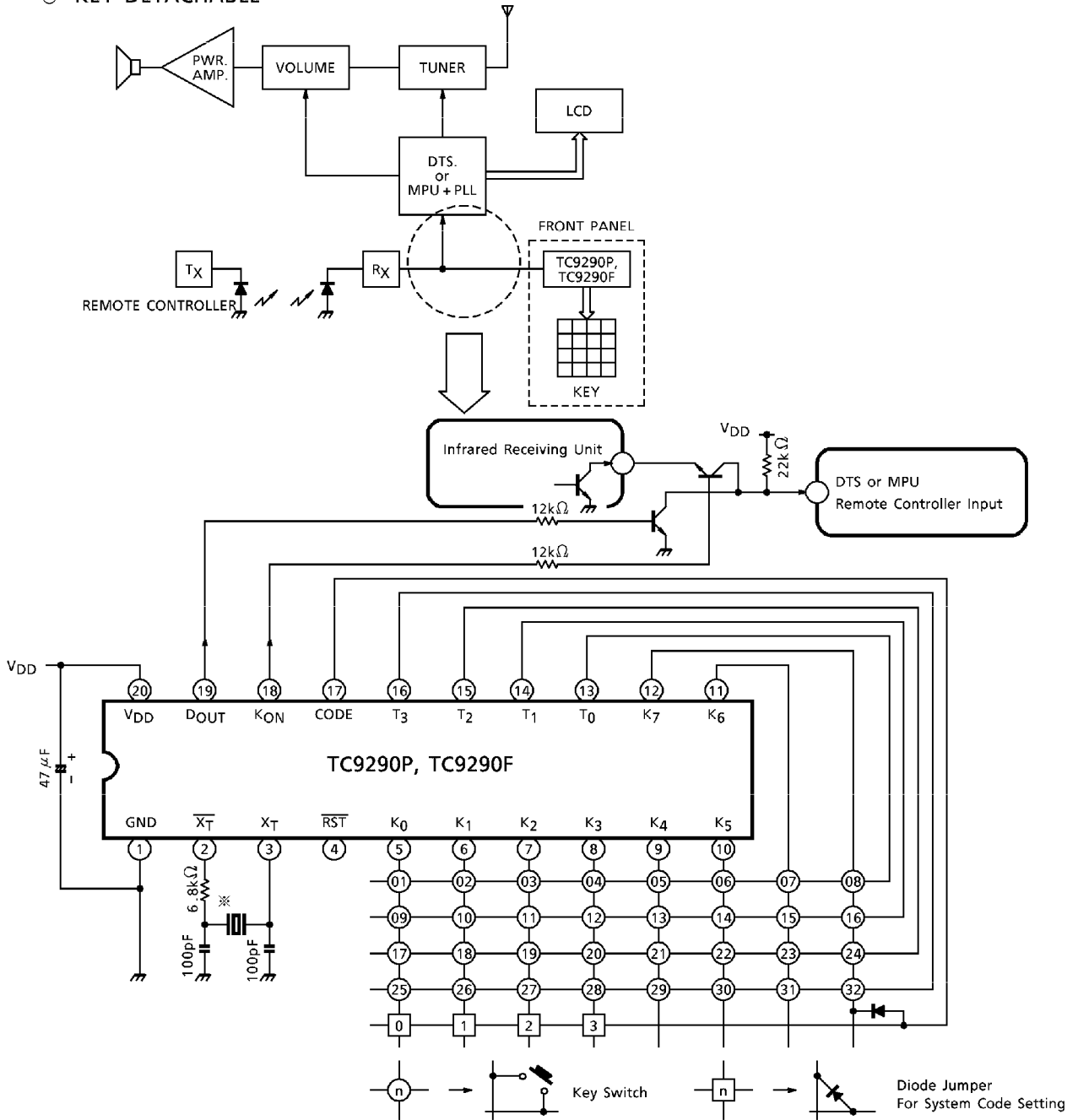

※ Ceramic Oscillator CSB455B (Murata Sesakusho) or Equivalent.

2. EXTENSION FOR INPUT KEY

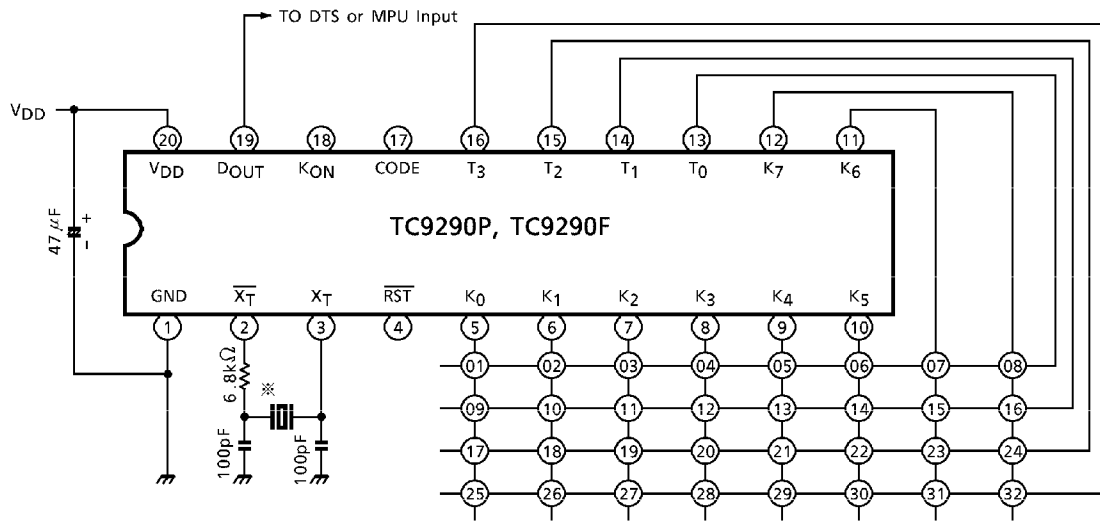

※ Ceramic Oscillator CSB455B (Murata Seisakusho) or Equivalent.

OUTLINE DRAWING
DIP20-P-300-2.54A

Unit : mm

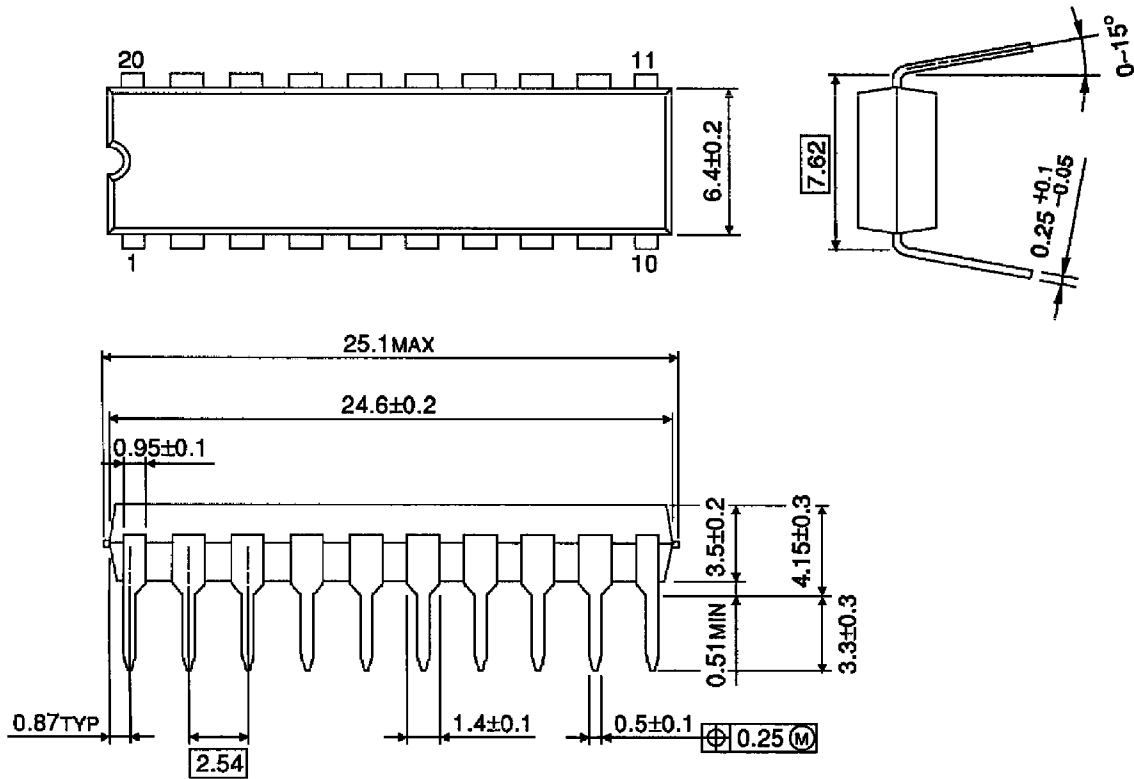

Weight : 1.4g (Typ.)

OUTLINE DRAWING
SOP20-P-300-1.27

Unit : mm

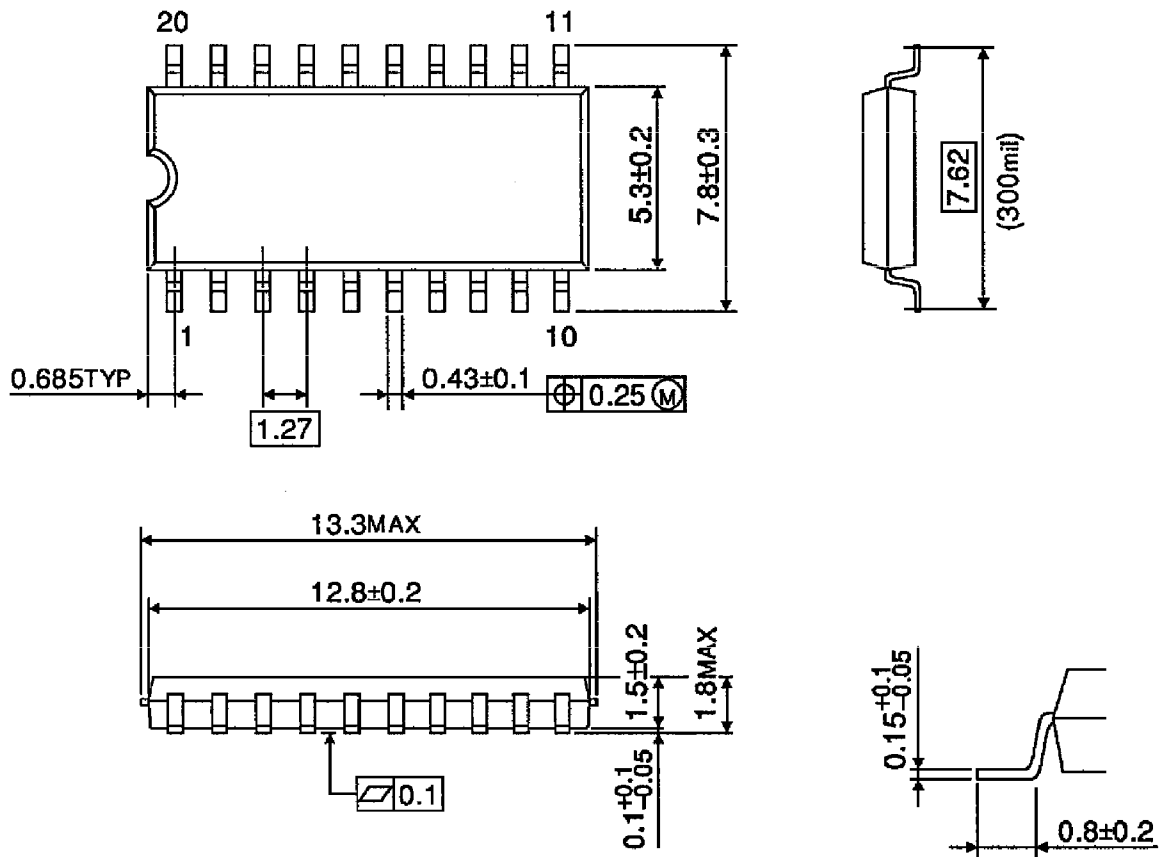

Weight : 0.48g (Typ.)