

**Features**

- Operating voltage: 4.5V~5.5V
- ADM algorithm
- DRAM options:
  - 256K
  - 64K
- Sampling rate options:
  - 32Kb
  - 16Kb
- Recording capacity options:
  - 2 seconds
  - 4 seconds
- Stop recording option
  - Silence control
  - Recording capacity control
- Built-in 2-stage microphone amplifier
- Built-in DRAM refresh circuit
- Voltage type D/A output
- Current type D/A output
- Talking back with a voice modulation
- Auto record and playback
- Auto power-off
- Selectable finite or infinite talking back repeating number
- Low power consumption

**Applications**

- Toys
- Education
- Parrot talking back
- Games
- Sound effect generators

**General Description**

The HT8654 is a single chip CMOS LSI using an ADM algorithm. It can talk back with a voice modulation, and operates with different frequencies when recording and playing.

The IC provides a recording capacity of 2 or 4 seconds for DRAMs of 64K and 256K. It has 2 stop recording functions. One is the silence con-

trol operation and the other is the recording capacity control operation. The repeating number of the device talking back can be set to finite or infinite.

The IC is offered in a dice form, 40-pin DIP and 32-pin DIP.

**Pin Assignment**

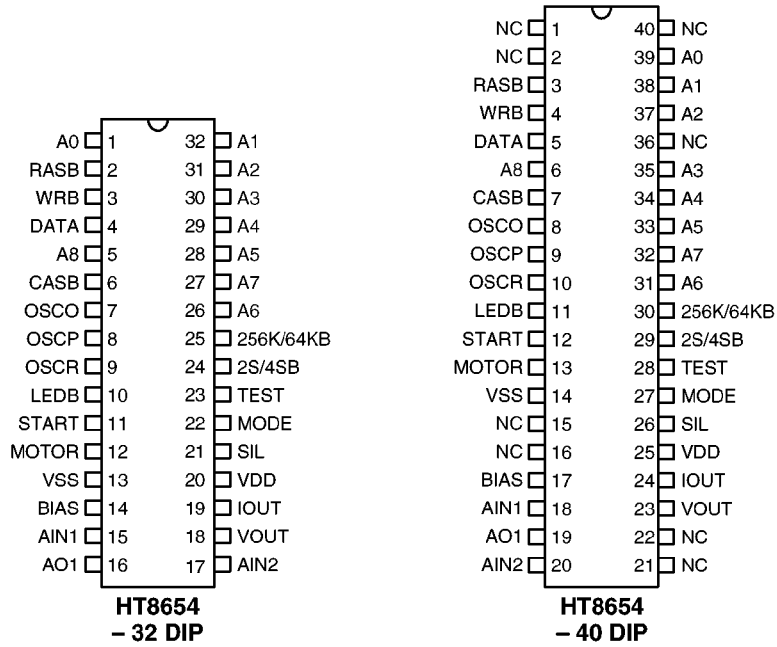

**Block Diagram**

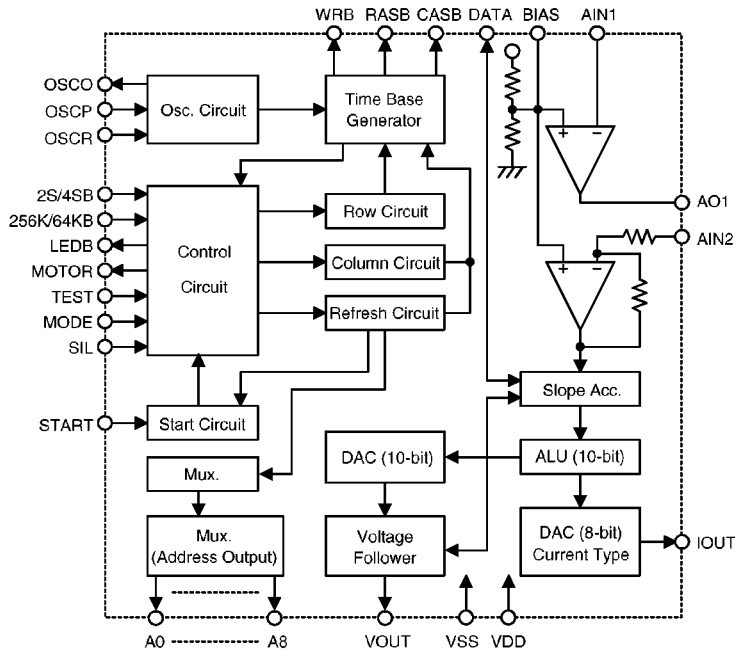

**Pad Coordinates**

Unit: mil

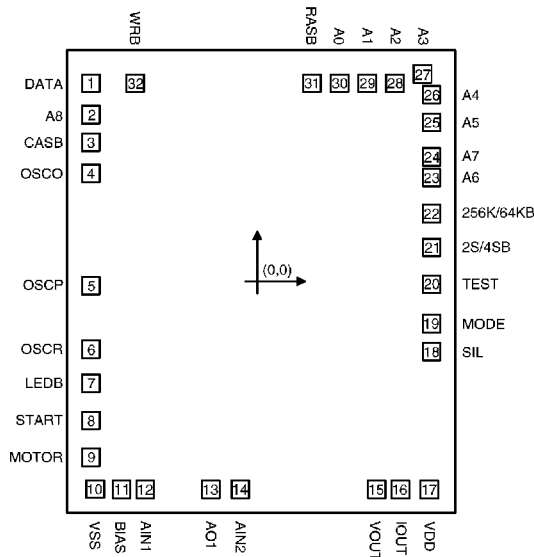
 Chip size: 131 × 153 (mil)<sup>2</sup>

Pad No.	X	Y	Pad No.	X	Y
1	-56.60	67.41	17	58.48	-70.65
2	-56.60	56.75	18	59.20	-23.85
3	-56.60	47.34	19	59.20	-14.31
4	-56.60	36.77	20	59.20	-0.95
5	-56.60	-1.49	21	59.20	11.57
6	-56.60	-22.95	22	59.20	23.13
7	-56.60	-34.65	23	59.20	35.33
8	-56.60	-47.34	24	59.20	42.36
9	-56.60	-59.76	25	59.20	54.18
10	-55.10	-70.61	26	59.20	63.59
11	-46.20	-70.65	27	56.14	70.605
12	-38.10	-70.65	28	46.73	67.41
13	-15.82	-70.65	29	37.33	67.41
14	-5.83	-70.65	30	27.92	67.41
15	40.57	-70.65	31	18.52	67.41
16	48.67	-70.65	32	-41.56	67.41

\* The IC substrate should be connected to VDD in the PCB layout artwork.

**Pad Description**

Pad No.	Pad Name	I/O	Internal Connection	Description
1	DATA	I/O	CMOS	DRAM data input/output
2	A8	O	CMOS	DRAM address output
3	CASB	O	CMOS	DRAM column address strobe
4	OSCO	O	—	Oscillator output
5	OSCP	I	—	Oscillator input for playing mode
6	OSCR	I	—	Oscillator input for recording mode
7	LEDB	O	NMOS Open Drain	LED indicator: Idle/Play state: LED is turned off Record state: LED flashes
8	START	O	NMOS Open Drain	System start pin
9	MOTOR	O	CMOS	Motor drive output (active high)
10	VSS	I	—	Negative power supply (GND)
11	BIAS	I	—	For internal AMP bias de-coupling

Pad No.	Pad Name	I/O	Internal Connection	Description
12	AIN1	I	—	Internal AMP first stage input (inverted)
13	AO1	O	—	Internal AMP first stage output
14	AIN2	I	—	Internal AMP second stage input (inverted)
15	VOUT	O	—	Voltage type audio output for an external power AMP
16	IOU	O	—	Current type audio output for an external transistor
17	VDD	I	—	Positive power supply
18	SIL	I	Pull-High	Recording stop control: Open/High: Silence detected or recording capacity full control Low: Recording capacity full control
19	MODE	I	Pull-High	Talking back repeating number selection: Open/High: Finite Low: Infinite
20	TEST	I	Pull-Low	For IC test only
21	2S/4SB	I	Pull-High	Recording capacity selection: Open/High: 2 seconds Low: 4 seconds
22	256K/64KB	I	Pull-High	DRAM size selection Open/High: 256K Low: 64K
23, 24	A6, A7	O	CMOS	DRAM address output
25~30	A5~A0	O	CMOS	DRAM address output
31	RASB	O	CMOS	DRAM row address strobe
32	WRB	O	CMOS	DRAM write enable

### Absolute Maximum Ratings\*

Supply Voltage ..... -0.3V to 6V      Storage Temperature ..... -50°C to 125°C  
 Input Voltage .....  $V_{SS}-0.3V$  to  $V_{DD}+0.3V$       Operating Temperature ..... -20°C to 70°C

\*Note: These are stress ratings only. Stresses exceeding the range specified under “Absolute Maximum Ratings” may cause substantial damage to the device. Functional operation of this device at other conditions beyond those listed in the specification is not implied and prolonged exposure to extreme conditions may affect device reliability.

**Electrical Characteristics**

(Ta=25°C)

Symbol	Parameter	Test Conditions		Min.	Typ.	Max.	Unit
		V <sub>DD</sub>	Conditions				
V <sub>DD</sub>	Operating Voltage	—	—	4.5	—	5.5	V
I <sub>DD</sub>	Operating Current	5V	No load, f <sub>OSC</sub> =640kHz	—	1.5	3.0	mA
I <sub>STB</sub>	Standby Current	5V	—	—	600	1000	μA
I <sub>O</sub>	Max. IOUT Source Current	5V	V <sub>OH</sub> =0.6V	-1.5	-3.0	—	mA
I <sub>OL</sub>	MOTOR Source Current	5V	V <sub>OH</sub> =4.5V	-1	-3.5	—	mA
I <sub>OL</sub>	LED Sink Current	5V	V <sub>OL</sub> =0.5V	0.5	1.0	—	mA
V <sub>IH</sub>	“H” Input Voltage	—	—	0.8V <sub>DD</sub>	—	V <sub>DD</sub>	V
V <sub>IL</sub>	“L” Input Voltage	—	—	0	—	0.2V <sub>DD</sub>	V
V <sub>OUT</sub>	Max. VOUT Output Voltage	5V	R <sub>L</sub> >50kΩ	—	1.5	—	V <sub>P-P</sub>
f <sub>OSC</sub>	Oscillating Frequency	5V	R <sub>OSC</sub> =43kΩ	—	640	—	kHz

**Functional Description**

The HT8654 is a single chip LSI with talking back capacity and voice modulation. It operates with two independent frequencies for recording or playing. By changing the playing frequency, various sound effects can be generated.

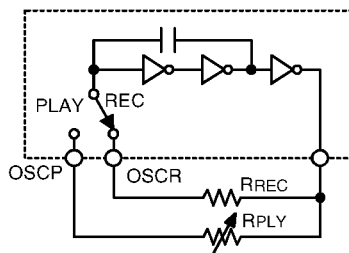

**Record function**

The HT8654 provides two kinds of recording capacity as well as DRAM interfaces. The recording capacity along with DRAM determine the size of the sampling rate as shown in the following table: (For f<sub>OSC</sub>=640kHz)

Recording Capacity (2S/4SB)	DRAM (64K/256KB)	Sampling Rate
2 seconds	64K	32Kb
2 seconds	256K	32Kb
4 seconds	64K	16Kb
4 seconds	256K	32Kb

Recording starts whenever a sound input is detected. It then stops once a 0.6 seconds of silence is detected or the recording capacity is full. After that, talking back comes into play.

The IC provides two ways to terminate the recording and start the talking back, depending on the status of the SIL pin.

• Silence control

The IC stops to talk back when SIL is left open (internal pull-high), and

- \* 0.6 seconds of silence is detected during recording or
- \* The recording capacity is full. (the recording capacity is determined by the 2S/4SB pin.)

• Recording capacity control

The IC stops to talk back when SIL is connected to VSS and the recording capacity is full.

**Play function**

The HT8654 provides two kinds of operation mode which are determined by the status of the MODE pin. When MODE is left open (internal pull-high) the IC operates in the finite state and keeps talking back until the designated repeating number of talking back is reached. The range of repeating number can be from 1~7 times by mask option. Each repeat playing has a silence interval of 0.4 seconds. On the other hand, when MODE is connected to VSS, the IC operates in the infinite state and repeats talking back until MODE returns to the finite state or power is turned off.

The sound pitch can be changed by selecting different values of RPLY.

**Motor**

The HT8654 provides a motor driving pin. The motor is turned on during playing but off once talking back is terminated.

**LED**

The LED pin displays the status of the HT8654. LED is switched off when the IC is in the standby or playing state. Its intensity varies inversely with the sound volume when the IC is in the recording state.

**Operating flowchart**

- Silence control and finite repeating mode: (SIL open, MODE open)

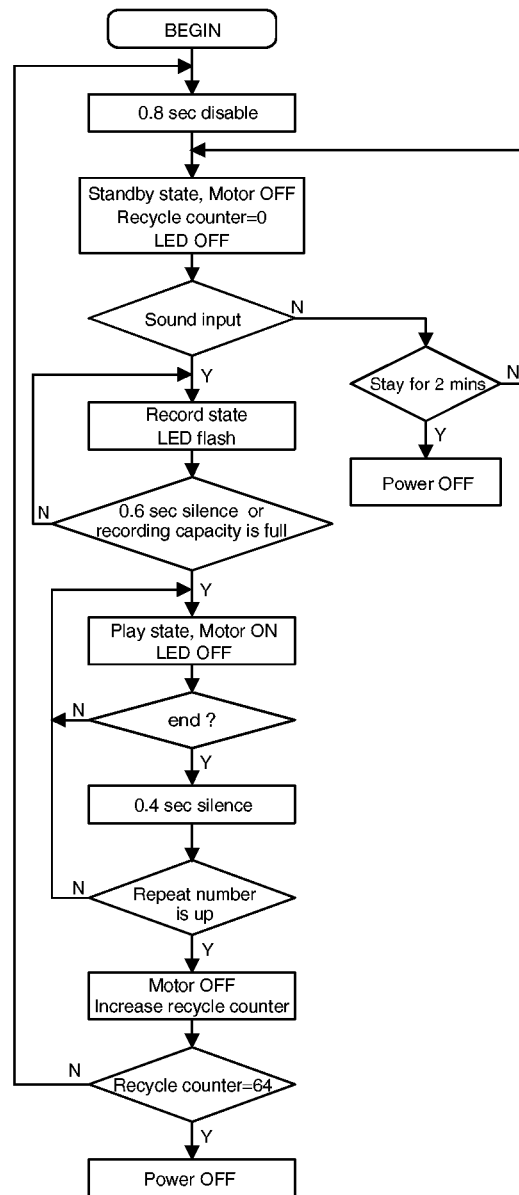

- Recording capacity control and finite repeating mode (SIL=VSS, MODE open)

- Silence control and infinite repeating mode (SIL open, MODE=VSS)

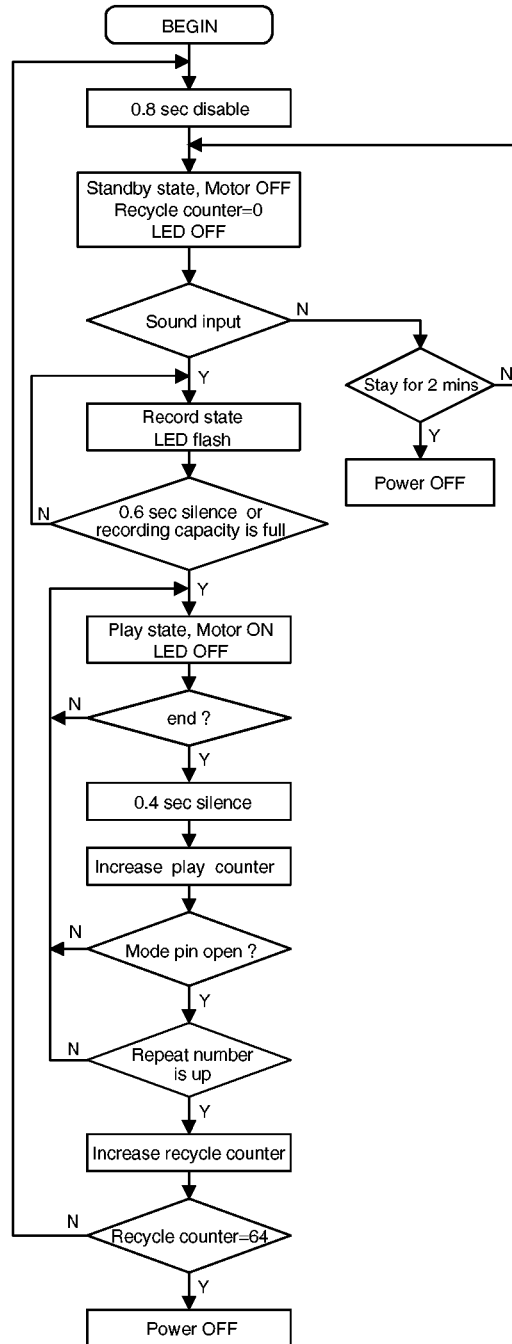
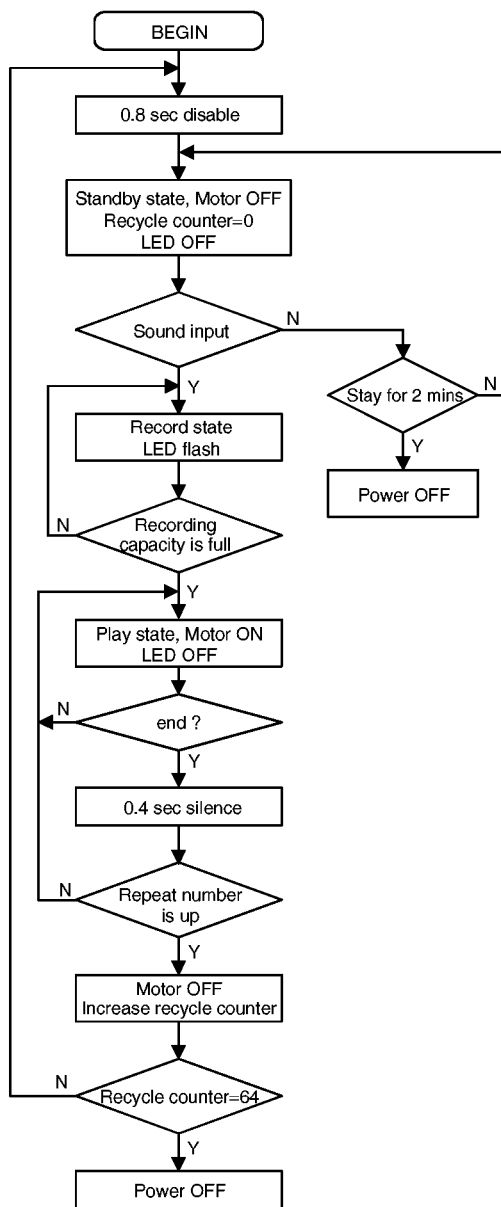

- Recording capacity control and infinite repeat mode (SIL=VSS, MODE=VSS)

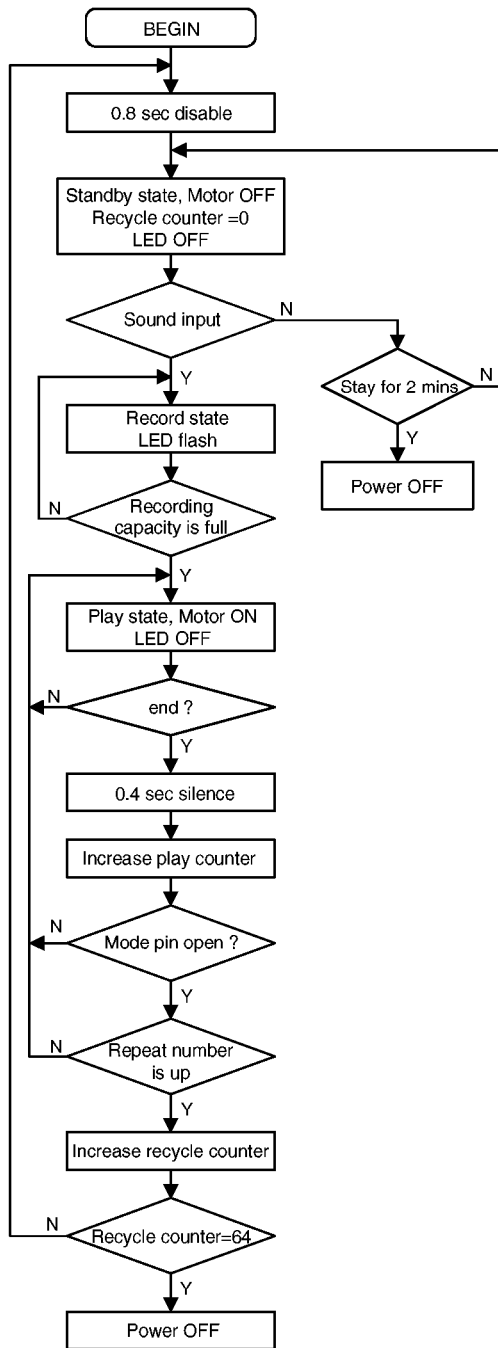



Package application (32-pin DIP)

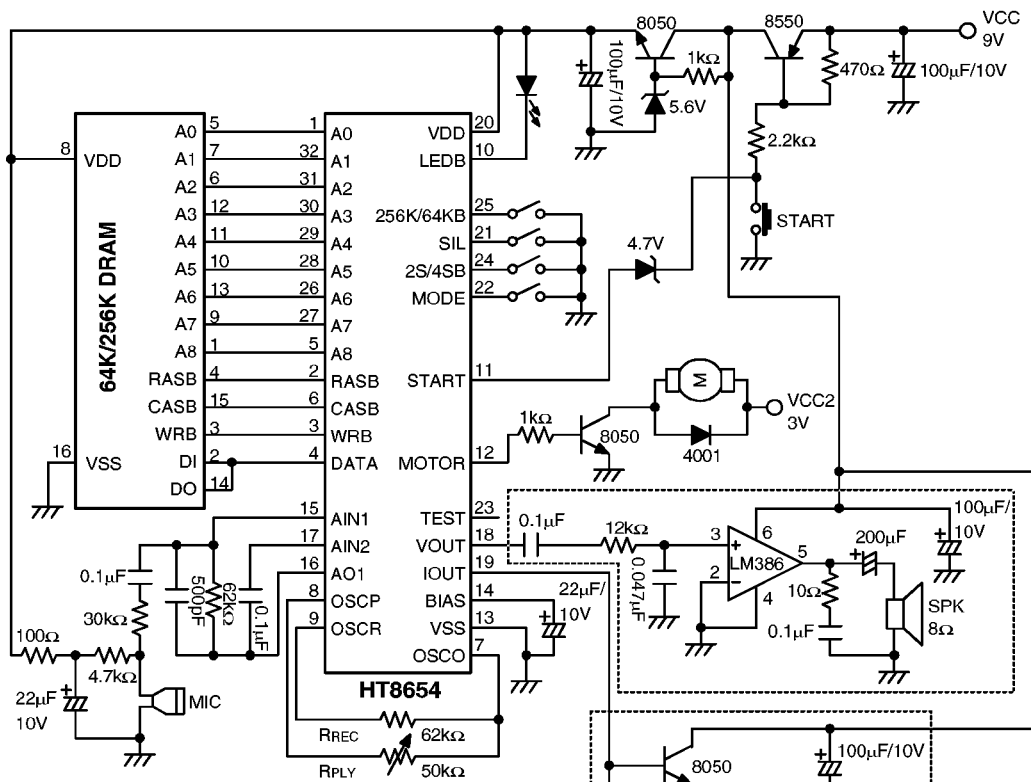

- Note: 1. RREC=62K, fREC=460kHz  
 RPLY=43K, fPLY=640kHz  
 2. By changing the RREC & RPLY, various sound effects can be generated.  
 3. Either LM386 application or transistor application can be used.

Package application (40-pin DIP)

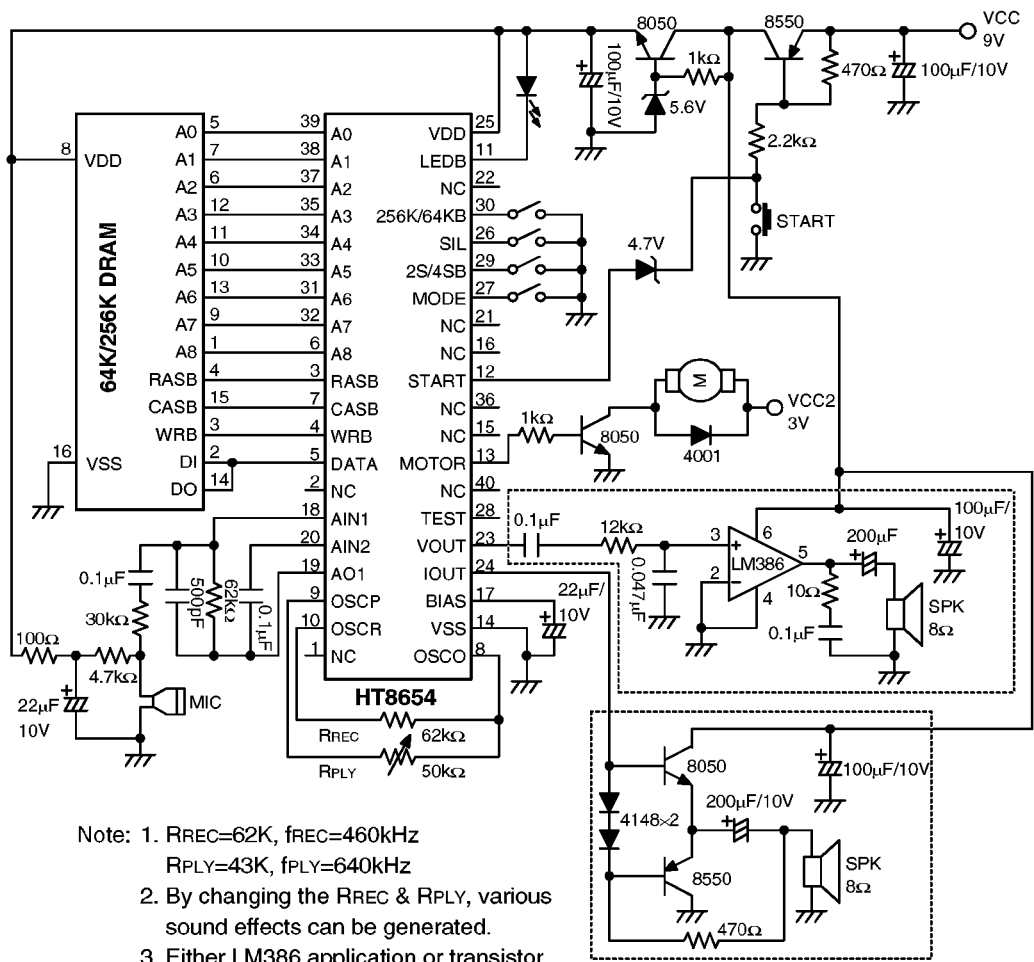

- Note: 1. RREC=62K, fREC=460kHz  
 RPLY=43K, fPLY=640kHz  
 2. By changing the RREC & RPLY, various sound effects can be generated.  
 3. Either LM386 application or transistor application can be used.