



NT56V6610C0T (8Mx8)
NT56V6620C0T (4Mx16)
64Mb Synchronous DRAM
Data Sheet



**64Mb : x8 x16
PC133 / PC100 Synchronous DRAM**

Revision Log

Rev Date	Version	Content of Modification
Sep / 1999	1.0	1 st Revision
June / 2000	1.1	Added speed grade –75B (PC133@CL3 & PC100@CL2) to following items as : <ol style="list-style-type: none"> 1. Product Family 2. DC currents 3. AC Timing Parameters

Contents

Revision Log	02
Table of Contents	03
Description	05
Features	06
Product Family	07
Pin Assignment	07
Pin Description	08
Functional Block Diagram	09
Ordering Information	10
DC Characteristics	11
Absolute Maximum Ratings	11
Recommended DC Operating Conditions	11
Capacitance	11
DC Electrical Characteristics	11
DC Output Load Circuit	12
Operating, Standby, and Refresh Currents	13
AC Characteristics	14
AC Output Load Circuits	14
AC Timing Parameters	15
Clock and Clock Enable Parameters	15
Common Parameters	15
Mode Register Set Cycle	15
Read Cycle	16
Refresh Cycle	16
Write Cycle	16
Clock Frequency and Latency	16
Command Truth Table	18
DEVICE OPERATIONS	24
Power On and Initialization	24
Programming the Mode Register	24
Mode Register Definition	24
Burst Mode Operation	25
Burst Length and Sequence	25
Bank Activate Command	26
Bank Select	26
Read and Write Access Modes	27
Burst Read Command	28
Read Interrupted by a Read	29
Read Interrupted by a Write	30
Burst Write Command	30
Write Interrupted by a Write	31
Write Interrupted by a Read	31
Burst Stop Command	32
Auto-Precharge Operation	33
Precharge Command	37
Bank Selection for Precharge by Address Bits	37
Precharge Termination	39
Automatic Refresh Command	40
Self Refresh Command	40
Power Down Mode	41
Data Mask	41



**64Mb : x8 x16
PC133 / PC100 Synchronous DRAM**

No Operation Command	41
Deselect Command	41
Clock Suspend Mode	42
Timing Diagrams	43
AC Parameters for Write Timing	43
AC Parameters for Read Timing (3/3/3)	44
AC Parameters for Read Timing (2/2/2)	45
AC Parameters for Read Timing (3/2/2)	46
AC Parameters for Read Timing (3/3/3)	47
Mode Register Set	48
Power On Sequence and Auto Refresh (CBR)	49
Clock Suspension, DQM during Burst Read	50
Clock Suspension, DQM during Burst Write	51
Power Down Mode and Clock Suspend	52
Auto Refresh (CBR)	54
Self Refresh (Entry and Exit)	54
Random Row Read (Interleaving Banks) with Precharge	55
Random Row Read (Interleaving Banks) with Auto Precharge	56
Random Row Write (Interleaving Banks) with Auto Precharge	57
Random Row Write (Interleaving Banks) with Precharge	58
Read-Write Cycle	59
Interleaved Column Read Cycle	60
Auto Precharge after Read Burst	61
Auto Precharge after Write Burst	62
Burst Read and Single Write Operation	63
Full Page Burst Read and Single Write Operation	64
/CS Function (Only /CS signal needs to be asserted at minimum rate)	65
Package Dimension	66



Description

The NT56V6610C0T and NT56V6620C0T are four-bank Synchronous DRAMs organized as 2Mbit x 8 I/O x 4 Bank and 1Mbitx16I/Ox4Bank, respectively. These synchronous devices achieve high-speed data transfer rates of up to 133MHz by employing a pipeline chip architecture that synchronizes the output data to a system clock. The chip is fabricated with NANYA advanced 64Mbit single transistor CMOS DRAM process technology.

The device is designed to comply with all JEDEC standards set for synchronous DRAM products, both electrically and mechanically. All of the control, address, and data input/output (I/O or DQ) circuits are synchronized with the positive edge of an externally supplied clock. /RAS, /CAS, /WE, and /CS are pulsed signals which are examined at the positive edge of each externally applied clock (CLK). Internal chip operating modes are defined by combinations of these signals and a command decoder initiates the necessary timings for each operation. A fourteen bit address bus accepts address data in the conventional /RAS /CAS multiplexing style. Twelve row addresses (A0-A11) and two bank select addresses (A12, A13) are strobed with /RAS. Ten column addresses (A0-A9) plus bank select addresses and A10 are strobed with /CAS. Column address A9 is dropped on the x8 device and column addresses A8 and A9 are dropped on the x16 device. Access to the lower or upper DRAM in a stacked device is controlled by /CS0 and /CS1, respectively.

Prior to any access operation, the /CAS latency, burst length, and burst sequence must be programmed into the device by address inputs A0-A9 during a mode register set cycle. In addition, it is possible to program a multiple burst sequence with single write cycle for write through cache operation.

Operating the four memory banks in an interleave fashion allows random access operation to occur at a higher rate than is possible with standard DRAMs. A sequential and gapless data rate of up to 133MHz is possible depending on burst length, /CAS latency, and speed grade of the device. Simultaneous operation of both decks of a stacked device is allowed, depending on the operation being done. Auto Refresh (CBR), Self Refresh, and Low Power operation are supported.

Feature

- JEDEC standard 3.3V± 0.3V Power Supply
- LVTTTL compatible inputs and outputs
- Four Banks controlled by Bank Selects(A12/A13)
- Single Pulsed /RAS Interface
- Fully Synchronous to Positive Clock Edge
- MRS cycle with address key programmability for :
 - CAS Latency (2, 3)
 - Burst Length (1, 2, 4, 8 & Full-page)
 - Burst Type (Sequential or Interleave)
- Multiple Burst Read with Single Write Option
- Automatic and Controlled Precharge Command
- Data Mask for Read/Write control (x8)
- Dual Data Mask for byte control (x16)
- Auto Refresh (CBR) and Self Refresh
- Suspend Mode and Power Down Mode
- Standard Power operation
- 4096 refresh cycles/64ms
- Random Column Address every CLK (1-N Rule)
- Package:54-pin 400 mil TSOP-Type II



Product Family

Part NO.	Organization	Speed (MHz@CL-tRP-tRCD)		Interface	Package
NT56V6610C0T-75B	8M x 8	133 MHz @ 3-3-3	100 MHz @ 2-2-2	LVTTL	54pin TSOP II
NT56V6610C0T-75		133 MHz @ 3-3-3	-		
NT56V6610C0T-8B		125 MHz @ 3-3-3	100MHz @ 2-2-2		
NT56V6610C0T-8A		125 MHz @ 3-3-3	100MHz @ 3-2-2		
NT56V6620C0T-7	4M x 16	143 MHz @ 3-3-3	-		
NT56V6620C0T-75B		133 MHz @ 3-3-3	100 MHz @ 2-2-2		
NT56V6620C0T-75		133 MHz @ 3-3-3	-		
NT56V6620C0T-8B		125 MHz @ 3-3-3	100MHz @ 2-2-2		
NT56V6620C0T-8A		125 MHz @ 3-3-3	100MHz @ 3-2-2		

Pin Assignment (Top View)

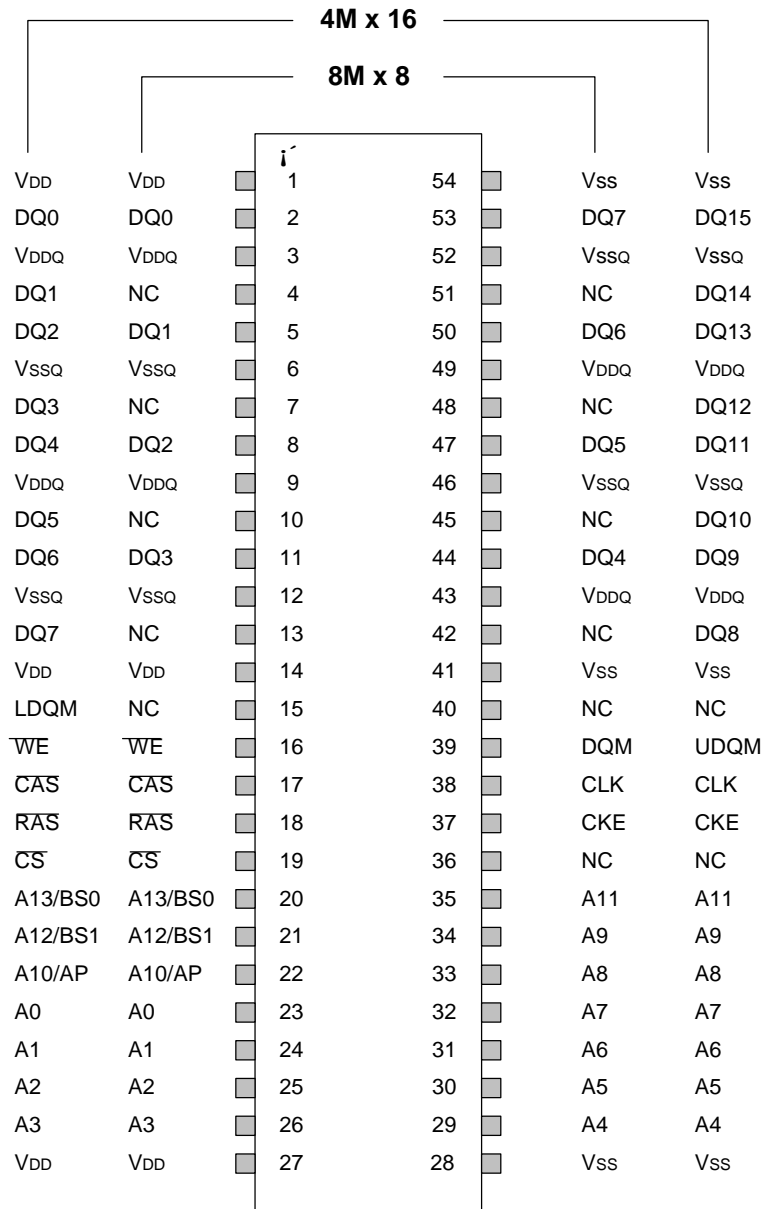

54-pin Plastic TSOP-II 400 mil

**64Mb : x8 x16
PC133 / PC100 Synchronous DRAM**

Pin Description

CLK	Clock Input	DQ0-DQ15	Data Input/Output
CKE	Clock Enable	DQM, LDQM, UDQM	Data Mask
/CS (/CS0, /CS1)	Chip Select	VDD	Power (+3.3V)
/RAS	Row Address Strobe	VSS	Ground
/CAS	Column Address Strobe	VDDQ	Power for DQs (+3.3V)
/WE	Write Enable	VSSQ	Ground for DQs
BS1, BS0 (A12, A13)	Bank Select	NC	No Connection
A0-A11	Address Inputs	--	--

Input / Output Functional Description

Symbol	Type	Polarity	Function
CLK	Input	Positive Edge	The system clock input. All of the SDRAM inputs are sampled on the rising edge of the clock.
CKE	Input	Active High	Activates the CLK signal when high and deactivates the CLK signal when low. By deactivating the clock, CKE low initiates the Power Down mode, Suspend mode, or the Self Refresh mode.
/CS	Input	Active Low	/CS enables the command decoder when low and disables the command decoder when high. When the command decoder is disabled, new commands are ignored but previous operations continue.
/RAS, /CAS /WE	Input	Active Low	When sampled at the positive rising edge of the clock, /CAS, /RAS, and /WE define the operation to be executed by the SDRAM.
BS1, BS0 (A12, A13)	Input	--	Selects which bank is to be active.
A0 - A11	Input	--	During a Bank Activate command cycle, A0-A11 defines the row address (RA0-RA11) when sampled at the rising clock edge. During a Read or Write command cycle, A0-A9 defines the column address (CA0-CA9) when sampled at the rising clock edge. A10 is used to invoke auto-precharge operation at the end of the burst read or write cycle. If A10 is high, auto-precharge is selected and BS0, BS1 defines the bank to be precharged. If A10 is low, autoprecharge is disabled. During a Precharge command cycle, A10 is used in conjunction with BS0, BS1 to control which bank(s) to precharge. If A10 is high, all banks will be precharged regardless of the state of BS. If A10 is low, then BS0 and BS1 are used to define which bank to precharge.
DQ0-DQ15	Input-Output	--	Data Input/Output pins operate in the same manner as on conventional DRAMs
DQM LDQM UDQM	Input	Active High	The Data Input/Output mask places the DQ buffers in a high impedance state when sampled high. In x16 products, LDQM and UDQM control the lower and upper byte I/O buffers, respectively. In Read mode, DQM has a latency of two clock cycles and controls the output buffers like an output enable. DQM low turns the output buffers on and DQM high turns them off. In Write mode, DQM has a latency of zero and operates as a word mask by allowing input data to be written if it is low but blocks the write operation if DQM is high.
VDD, VSS	Supply	--	Power and ground for the input buffers and the core logic.
VDDQ, VSSQ	Supply	--	Isolated power supply and ground for the output buffers to provide improved noise immunity.

Functional Block Diagram

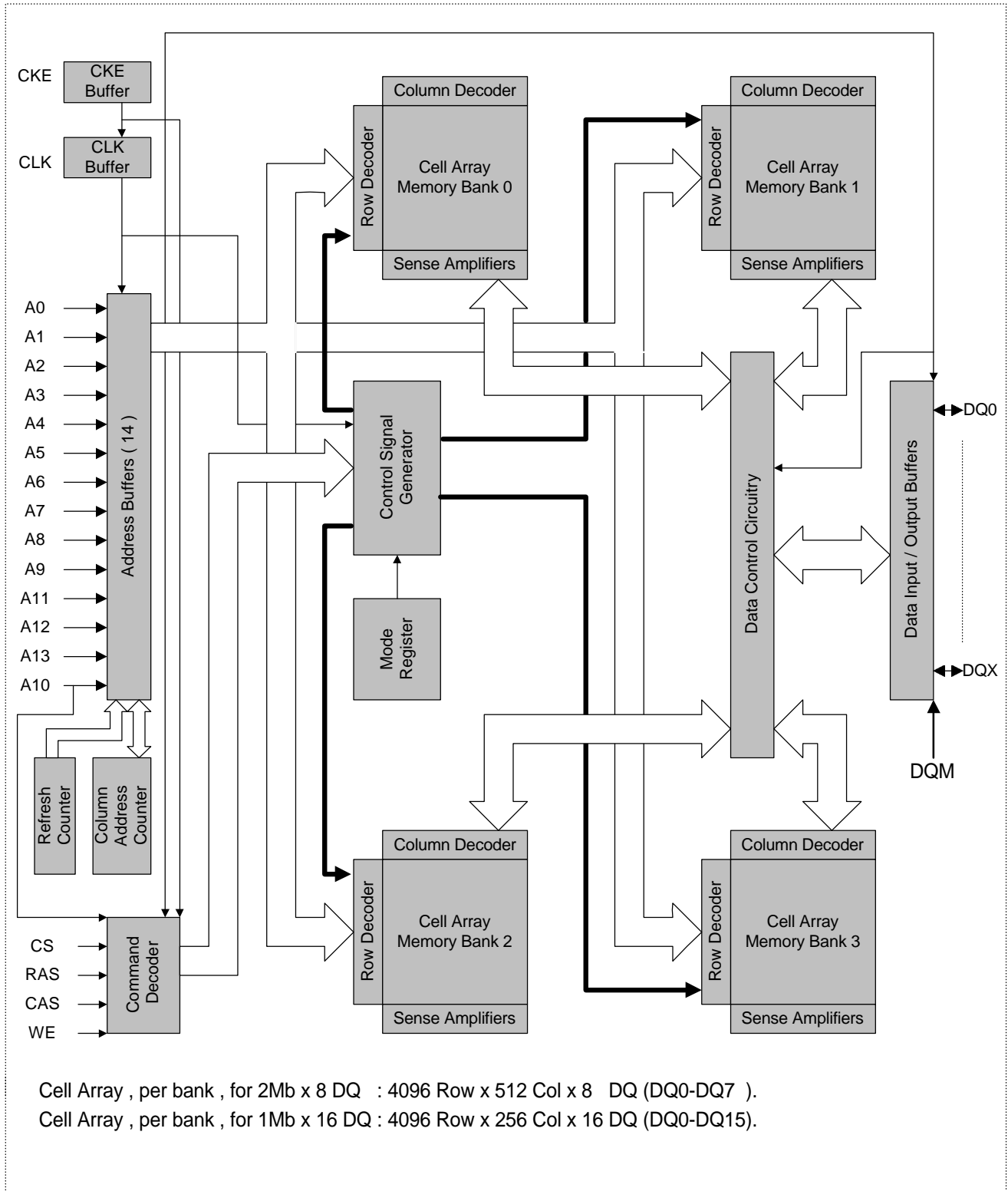



Part Number Guide

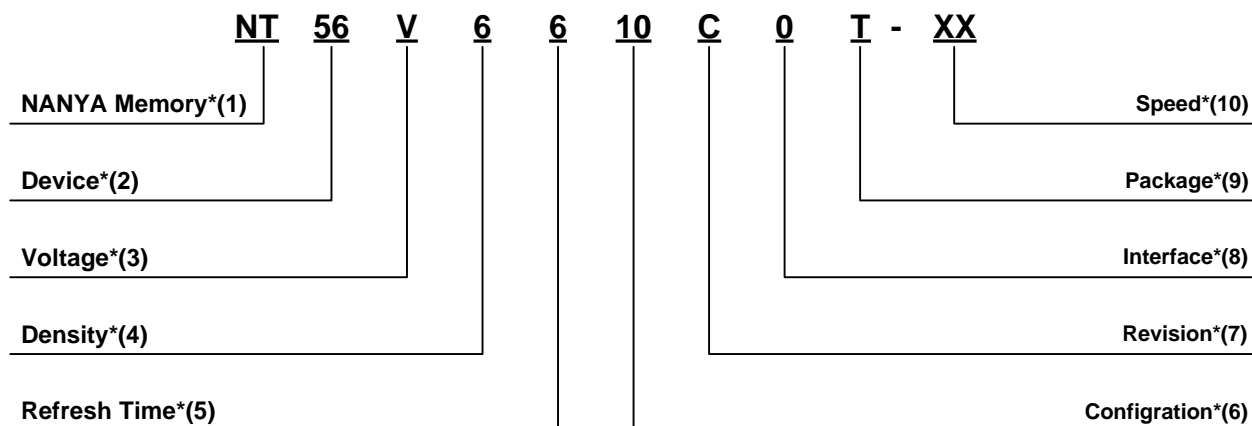

(1) NANYA Memory

(6) Configuration

- 10 ----- 4 bank, x 8
- 20 ----- 4 bank, x 16

(2) Device

- 56 ----- SDRAM

(7) Revision

- A ----- 1st version
- B ----- 2nd version
- C ----- 3rd version
- D ----- 4th version

(3) Voltage

- V ----- 3.3V

(8) Interface

- 0 ----- LVTTTL
- 1 ----- SSTL

(4) Density

- 1 ----- 16M
- 6 ----- 64M
- 2 ----- 128M

(9) Package

- T -----TSOP II
- F -----TQFP
- Q -----QFP

(5) Refresh Time

- 7 ----- 2K/32ms
- 6 ----- 4K/64ms

(10) Speed

- 7 -----143MHz
- 75 -----133MHz
- 8 -----125MHz
- 10 -----100MHz

DC Characteristics

Absolute Maximum Ratings

Symbol	Parameter	Rating	Units	Notes
VDD	Power Supply Voltage	-0.3 to +4.6	V	1
VDDQ	Power Supply Voltage for Output	-0.3 to +4.6	V	1
VIN	Input Voltage	-0.3 to $V_{DD}+0.3$	V	1
VOUT	Output Voltage	-0.3 to $V_{DD}+0.3$	V	1
TA	Operating Temperature (ambient)	0 to +70	°C	1
TSTG	Storage Temperature	-55 to +125	°C	1
PD	Power Dissipation	1.0	W	1
IOUT	Short Circuit Output Current	50	mA	1

1. Stresses greater than those listed under "Absolute Maximum Ratings" may cause permanent damage to the device.
This is a stress rating only and functional operation of the device at these or any other conditions above those indicated in the operational sections of this specification is not implied. Exposure to absolute maximum rating conditions for extended periods may affect reliability.

Recommended DC Operating Conditions ($T_A = 0$ to 70 °C)

Symbol	Parameter	Rating			Units	Notes
		Min.	Typ.	Max.		
VDD	Power Voltage	3.0	3.3	3.6	V	1
VDDQ	Power Voltage for Output	3.0	3.3	3.6	V	1
V _{IH}	Input High Voltage	2.0	-	$V_{DD} + 0.3$	V	1,2
V _{IL}	Input Low Voltage	-0.3	-	0.8	V	1,3

- All voltages referenced to V_{SS} and V_{SSQ} .
- $V_{IH}(\text{max}) = V_{DD} / V_{DDQ} + 1.2V$ for pulse width $\leq 5\text{ns}$
- $V_{IL}(\text{min}) = V_{SS} / V_{SSQ} - 1.2V$ for pulse width $\leq 5\text{ns}$.

Capacitance ($T_A = 25$ °C, $f = 1\text{MHz}$, $V_{DD} = 3.3V \pm 0.3V$)

Symbol	Parameter	Min.	Typ.	Max.	Units	Notes
C _I	Input Capacitance (A0-A11, BS0, BS1, /CS, /RAS, /CAS, /WE, CKE, DQM)	2.5	3.0	3.8	pF	1
	Input Capacitance (CLK)	2.5	2.8	3.5		
C _O	Output Capacitance (DQ0 – DQ15)	4.0	4.5	6.5		

- Multiply given planar values by 2 for 2-High stacked device except /CS.



DC Electrical Characteristics ($T_A = 0$ to $+70$ °C , $V_{DD} = 3.3V \pm 0.3V$)

Symbol	Parameter	Min.	Max.	Units	Notes
$I_{I(L)}$	Input Leakage Current, any input ($0.0V \leq V_{IN} \leq V_{DD}$), All Other Pins Not Under Test = 0V	-1	+1	μA	1
$I_{O(L)}$	Output Leakage Current (D_{OUT} is disabled, $0.0V \leq V_{OUT} \leq V_{DDQ}$)	-1	+1	μA	1
V_{OH}	Output Level (LVTTTL) Output "H" Level Voltage ($I_{OUT} = -2.0mA$)	2.4	-	V	-
V_{OL}	Output Level (LVTTTL) Output "L" Level Voltage ($I_{OUT} = +2.0mA$)	-	0.4	V	-

1. Multiply given planar values by 2 for 2-High stacked device.

DC Output Load Circuit

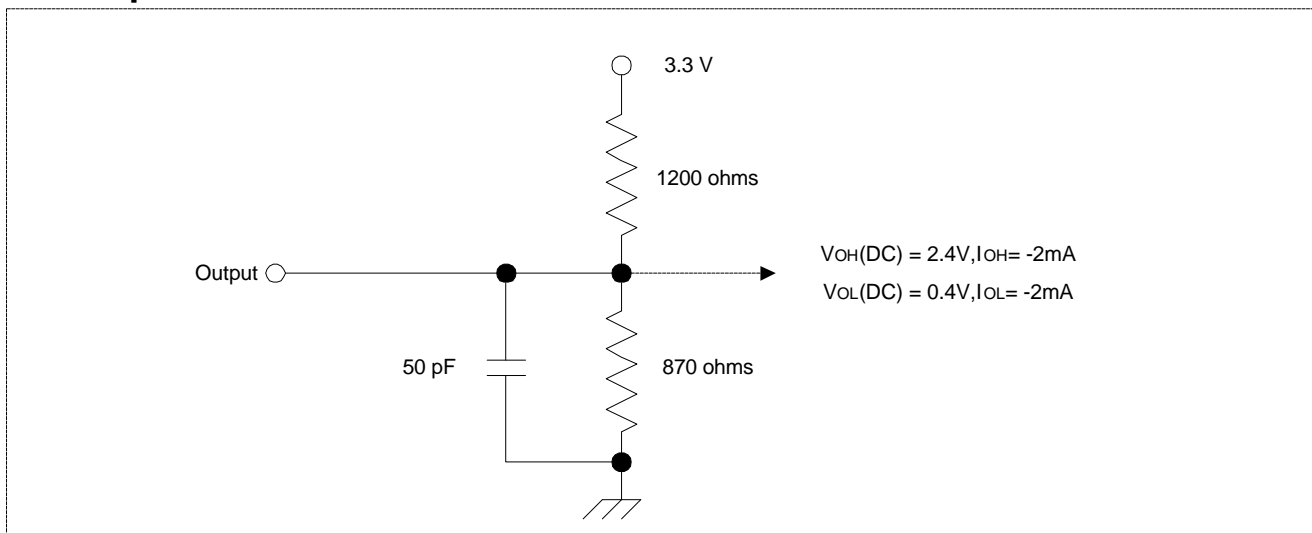



Operating, Standby, and Refresh Currents ($V_{DD} = 3.3V \pm 10\%$, $T_A = 0^\circ C$ to $70^\circ C$)

Parameter	Symbol	Test condition	Version				Unit	Note
			- 7	- 75(B)	- 8B	- 8A		
Operating current	ICC1	1 bank operation , $t_{RC} = t_{RC}(min)$, $t_{CK} = min$ Active-Precharge Command cycling without burst operation	75	75	70	70	mA	1,2,3
Precharge standby current in power-down mode	ICC2P	$CKE \leq V_{IL}(max)$, $t_{CK} = min$, $/CS = V_{IH}(min)$,	2				mA	1
	ICC2PS	$CKE \leq V_{IL}(max)$, $t_{CK} = \infty$, $/CS = V_{IH}(min)$	2				mA	1
Precharge standby current in non power-down mode	ICC2N	$CKE \geq V_{IH}(min)$, $/CS = V_{IH}(min)$, $t_{CK} = min$	35	35	25	25	mA	1
	ICC2NS	$CKE \geq V_{IH}(min)$, $t_{CK} = \infty$	5				mA	1,5
No Operating current (Active state : 4 bank)	ICC3P	$CKE \leq V_{IL}(max)$, $t_{CK} = min$	3				mA	1,7
	ICC3N	$CKE \geq V_{IH}(min)$, $/CS = V_{IH}(min)$, $t_{CK} = min$	40	40	30	30	mA	1,5
Operating current (Burst mode)	ICC4	$t_{CK} = min$, Read/ Write command cycling, Multiple banks active, gapless data, BL=4	120	120	90	90	mA	1,6
Auto(CBR) refresh current	ICC5	$t_{RC} = t_{RC}(min)$; $t_{CK} = min$ CBR command cycling	145	145	140	140	mA	1,3,4
Self refresh current	ICC6	$CKE \leq 0.2V$	1				mA	1

Note :

1. Currents given are valid for a single device. The total current for a stacked device depends on the operation being performed on the other deck.
2. These parameters depend on the cycle rate and are measured with the cycle determined by the minimum value of t and t . Input signals are changed up to three times during t (min).
3. The specified values are obtained with the output open.
4. Input signals are changed once during t (min).
5. Input signals are changed once during three clock cycles.
6. Active Standby Current will be higher if Clock Suspend is entered during a burst read cycle (add 1mA per DQ).
7. Input signals are stable.

AC Characteristics (T_A = 0 to +70 °C , V_{DD} = 3.3V ± 0.3V)

1. An initial pause of 200us, with DQM and CKE held high, is required after power-up. A precharge All Banks command must be given followed by a minimum of eight Auto (CBR) Refresh cycles before or after the Mode Register Set operation.
2. The Transition time is measured between V_{IH} and V_{IL} (or between V_{IL} and V_{IH}).
3. In addition to meeting the transition rate specification, the clock and CKE must transit between V_{IH} and V_{IL} (or between V_{IL} and V_{IH}) in a monotonic manner.
4. Load Circuit A : AC timing tests have V_{IL} = 0.4 V and V_{IH} = 2.4 V with the timing referenced to the 1.40V crossover point
5. Load Circuit A : AC measurements assume t_r = 1.0ns.
6. Load Circuit B : AC timing tests have V_{IL} = 0.8 V and V_{IH} = 2.0 V with the timing referenced to the 1.40V crossover point
7. Load Circuit B : AC measurements assume t_r = 1.2ns.

AC Output Load Circuits

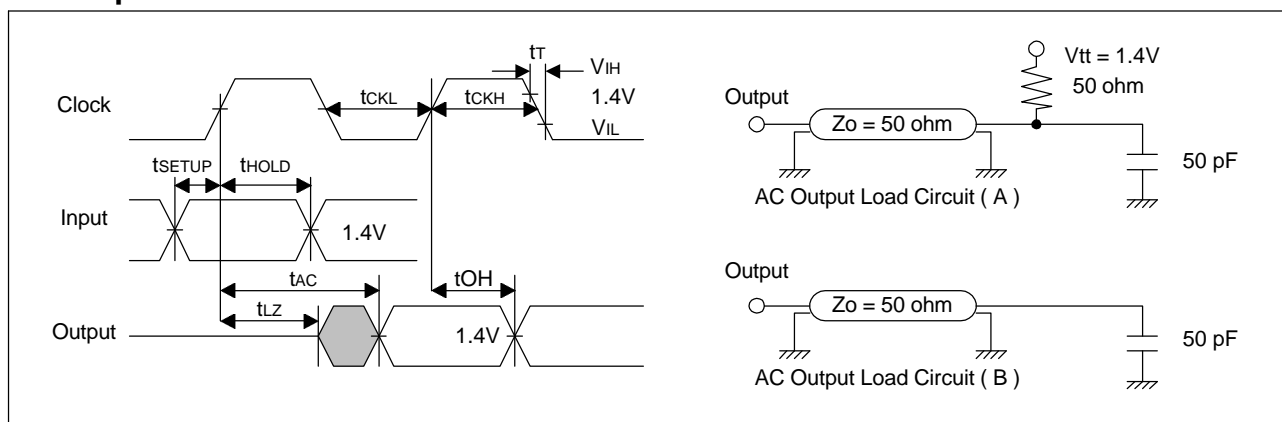

AC Timing Parameters

Clock and Clock Enable Parameters

Symbol	Parameter	- 7		- 75B		- 75		- 8B		- 8A		Unit	Note
		Min.	Max.	Min.	Max.	Min.	Max.	Min.	Max.	Min.	Max.		
tCK3	Clock Cycle Time, /CAS Latency = 3	7	-	7.5	-	7.5	-	8	-	8	-	ns	
tCK2	Clock Cycle Time, /CAS Latency = 2	-	-	10	-	-	-	10	-	12	-	ns	
tAC3(A)	Clock Access Time, /CAS Latency = 3	-	6	-	-	-	-	-	-	-	-	ns	1
tAC2(A)	Clock Access Time, /CAS Latency = 2	-	-	-	-	-	-	-	-	-	-	ns	1
tAC3(B)	Clock Access Time, /CAS Latency = 3	-	-	-	5.4	-	5.4	-	6	-	6	ns	2
tAC2(B)	Clock Access Time, /CAS Latency = 2	-	-	6	-	-	-	-	6	-	6	ns	2
tCKH	Clock High Pulse Width	3	-	2.5	-	2.5	-	3	-	3	-	ns	
tCKL	Clock Low Pulse Width	3	-	2.5	-	2.5	-	3	-	3	-	ns	
tCES	Clock Enable Set-up Time	2	-	1.5	-	1.5	-	2	-	2	-	ns	
tCEH	Clock Enable Hold Time	1	-	0.8	-	0.8	-	1	-	1	-	ns	
tSB	Power down mode Entry Time	0	7	0	7.5	0	7.5	0	10	0	12	ns	
tT	Transition Time (Rise and Fall)	0.5	10	0.5	10	0.5	10	0.5	10	0.5	10	ns	

1. Access time is measured at 1.4V. See AC Characteristics: notes 1, 2, 3, 4, 5 and load circuit A

2. Access time is measured at 1.4V. See AC Characteristics: notes 1, 2, 3, 6, 7 and load circuit B.

Common Parameters

Symbol	Parameter	- 7		- 75B		- 75		- 8B		- 8A		Unit	Note
		Min.	Max.	Min.	Max.	Min.	Max.	Min.	Max.	Min.	Max.		
tCS	Command Setup Time	2	-	1.5	-	1.5	-	2	-	2	-	ns	
tCH	Command Hold Time	1	-	0.8	-	0.8	-	1	-	1	-	ns	
tAS	Address and Bank Select Set-up Time	2	-	1.5	-	1.5	-	2	-	2	-	ns	
tAH	Address and Bank Select Hold Time	1	-	0.8	-	0.8	-	1	-	1	-	ns	
tRCD	/RAS to /CAS Delay	21	-	20	-	20	-	20	-	20	-	ns	1
tRC	Bank Cycle Time	70	-	65	-	65	-	70	-	70	-	ns	1
tRAS	Active Command Period	49	-	45	-	45	-	50	-	50	-	ns	1
tRP	Precharge Time	21	-	20	-	20	-	20	-	20	-	ns	1
tRRD	Bank to Bank Delay Time	14	-	15	-	15	-	20	-	20	-	ns	1
tCCD	/CAS to /CAS Delay Time	1	-	1	-	1	-	1	-	1	-	CLK	

1. These parameters account for the number of clock cycle and depend on the operating frequency of the clock, as follows: the number of clock cycles = specified value of timing / clock period (count fractions as a whole number).

64Mb : x8 x16
PC133 / PC100 Synchronous DRAM

Mode Register Set Cycle

Symbol	Parameter	- 7		- 75B		- 75		- 8B		- 8A		Unit	Note
		Min.	Max.	Min.	Max.	Min.	Max.	Min.	Max.	Min.	Max.		
tRSC	Mode Register Set Cycle Time	2	-	2	-	2	-	2	-	2	-	CLK	1

1. These parameters account for the number of clock cycle and depend on the operating frequency of the clock, as follows: the number of clock cycles = specified value of timing / clock period (count fractions as a whole number).

Read Cycle

Symbol	Parameter	- 7		- 75B		- 75		- 8B		- 8A		Unit	Note
		Min.	Max.	Min.	Max.	Min.	Max.	Min.	Max.	Min.	Max.		
tOH	Data Out Hold Time	2.5	-	-	-	-	-	2.5	-	2.5	-	ns	1
				2.7	-	2.7	-	3	-	3	-	ns	2
tLZ	Data Out to Low Impedance Time	0	-	0	-	0	-	0	-	0	-	ns	
tHZ3	Data Out to High Impedance Time	3	6	3	5.4	3	5.4	3	6	3	6	ns	3
tHZ2		-	-	-	-	-	-	3	6	3	8	ns	3
tDQZ	DQM Data Out Disable Latency	2	-	2	-	2	-	2	-	2	-	CLK	

1.AC Output Load Circuit A.

2.AC Output Load Circuit B.

3.Referenced to the time at which the output achieves the open circuit condition, not to output voltage levels.

Refresh Cycle

Symbol	Parameter	- 7		- 75B		- 75		- 8B		- 8A		Unit	Note
		Min.	Max.	Min.	Max.	Min.	Max.	Min.	Max.	Min.	Max.		
tREF	Refresh Period	-	64	-	64	-	64	-	64	-	64	ms	
tSREX	Self Refresh Exit Time	10	-	10	-	10	-	10	-	10	-	ns	

Write Cycle

Symbol	Parameter	- 7		- 75B		- 75		- 8B		- 8A		Unit	Note
		Min.	Max.	Min.	Max.	Min.	Max.	Min.	Max.	Min.	Max.		
tDS	Data In Set-up Time	2	-	1.5	-	1.5	-	2	-	2	-	ns	
tDH	Data In Hold Time	1	-	0.8	-	0.8	-	1	-	1	-	ns	
tDPL	Data input to Precharge	14	-	15	-	15	-	15	-	15	-	ns	
tDAL3	Data In to Active Delay /CAS Latency = 3	5	-	5	-	5	-	5	-	5	-	CLK	
tDAL2	Data In to Active Delay /CAS Latency = 2	-	-	-	-	-	-	4	-	3	-	CLK	
tDQW	DQM Write Mask Latency	0	-	0	-	0	-	0	-	0	-	ns	



Clock Frequency and Latency

Symbol	Parameter	- 7	- 75B		- 75	- 8B		- 8A		Units
tCK	Clock Frequency	143	133	100	133	125	100	125	83	MHz
tCK	Clock Cycle Time	7	7.5	10	7.5	8	10	8	12	ns
tAA	/CAS Latency	3	3	2	3	3	2	3	2	CLK
tRP	Precharge Time	3	3	2	3	3	2	3	2	CLK
tRCD	/RAS to /CAS Delay	3	3	2	3	3	2	3	2	CLK
tRC	Bank Cycle Time	10	9	7	9	9	7	9	6	CLK
tRAS	Minimum Bank Active Time	7	6	5	6	6	5	6	4	CLK
tDPL	Data In to Precharge	2	2	2	2	2	2	2	2	CLK
tDAL	Data In to Active/Refresh	5	5	4	5	5	4	5	4	CLK
tRRD	Bank to Bank Delay Time	2	2	2	2	2	2	2	2	CLK
tCCD	/CAS to /CAS Delay Time	1	1	1	1	1	1	1	1	CLK
tWL	Write Latency	0	0	0	0	0	0	0	0	CLK
tDQW	DQM Write Mask Latency	0	0	0	0	0	0	0	0	CLK
tDQZ	DQM Data Disable Latency	2	2	2	2	2	2	2	2	CLK
tCSL	Clock Suspend Latency	1	1	1	1	1	1	1	1	CLK

Command Truth Table

Function	Device State	CKE		/CS	/RAS	/CAS	/WE	DQM	A12, A13	A10	A11, A0-A9	Notes
		Previous Cycle	Current Cycle									
Mode Register Set	Idle	H	X	L	L	L	L	X	OP Code			
Auto (CBR) Refresh	Idle	H	H	L	L	L	H	X	X	X	X	
Entry Self Refresh	Idle	H	L	L	L	L	H	X	X	X	X	
Exit Self Refresh	Idle(Self-Refresh)	L	H	H	X	X	X	X	X	X	X	
				L	H	H	H					
Single Bank Precharge	See Current State Table	H	X	L	L	H	L	X	BS	L	X	2
Precharge all Banks	See Current State Table	H	X	L	L	H	L	X	X	H	X	
Bank Activate	Idle	H	X	L	L	H	H	X	BS	Row address		2
Write	Active	H	X	L	H	L	L	X	BS	L	Column	2
Write with Auto-Precharge	Active	H	X	L	H	L	L	X	BS	H	Column	2
Read	Active	H	X	L	H	L	H	X	BS	L	Column	2
Read with Auto-Precharge	Active	H	X	L	H	L	H	X	BS	H	Column	2
Burst Termination	Active	H	X	L	H	H	L	X	X	X	X	3,8
No Operation	Any	H	X	L	H	H	H	X	X	X	X	
Device Deselect	Any	H	X	H	X	X	X	X	X	X	X	
Clock Suspend Mode Entry	Active	H	L	X	X	X	X	X	X	X	X	4
Clock Suspend Mode Exit	Active	L	H	X	X	X	X	X	X	X	X	
Data Write/Output Enable	Active	H	X	X	X	X	X	L	X	X	X	5
Data Mask/Output Disable	Active	H	X	X	X	X	X	H	X	X	X	
Power Down Mode Entry	Idle/Active	H	L	H	X	X	X	X	X	X	X	6,7
				L	H	H	H					
Power Down Mode Exit	Any (Power Down)	L	H	H	X	X	X	X	X	X	X	6,7
				L	H	H	H					

- 1 All of the SDRAM operations are defined by states of /CS, /WE, /RAS, /CAS, and DQM at the positive rising edge of the clock. Operation of both decks of a stacked device at the same time is allowed, depending on the operation being performed on the other deck. Refer to the Current State Truth Table.
2. Bank Select(BS0,BS1):BS0,BS1=0,0 selects bank0; BS0,BS1=0,1 selects bank1; BS0,BS1=1,0 selects bank2; BS0,BS1= 1, 1 selects bank 3.
3. During a Burst Write cycle there is a zero clock delay; for a Burst Read cycle the delay is equal to the /CAS latency.
4. During normal access mode, CKE is held high and CLK is enabled. When it is low, it freezes the internal clock and extends data Read and Write operations. One clock delay is required for mode entry and exit.
5. The DQM has two functions for the data DQ Read and Write operations. During a Read cycle, when DQM goes high data clock timing the data outputs are disabled and become high impedance after a two-clock delay. DQM also provides a data mask function for Write cycles. When it activates, the Write operation at the clock is prohibited (zero clock latency).
6. All banks must be precharged before entering the Power Down Mode. (If this command is issued during a burst operation, the device state will be Clock Suspend Mode.) The Power Down Mode does not perform any refresh operations; therefore the device can't remain in this mode longer than the Refresh period (t_{REF}) of the device. One clock delay is required for mode entry and exit.
7. A No Operation or Device Deselect Command is required on the next clock edge following CKE going high.
8. Device state is full page burst operation. Use of this command to terminate other burst length operations is illegal.

Clock Enable (CKE) Truth Table

Current State	CKE		Command						Action	Notes
	Previous Cycle	Current Cycle	/CS	/RAS	/CAS	/WE	A12, A13	A11-A10		
Self Refresh	H	X	X	X	X	X	X	X	INVALID	1
	L	H	H	X	X	X	X	X	Exit Self Refresh with Device Deselect	2
	L	H	L	H	H	H	X	X	Exit Self Refresh with No Operation	2
	L	H	L	H	H	L	X	X	ILLEGAL	2
	L	H	L	H	L	X	X	X	ILLEGAL	2
	L	H	L	L	X	X	X	X	ILLEGAL	2
	L	L	X	X	X	X	X	X	Maintain Self Refresh	
Power Down	H	X	X	X	X	X	X	X	INVALID	1
	L	H	H	X	X	X	X	X	Power Down mode exit, all banks idle	2
	L	H	L	X	X	X	X	X	ILLEGAL	2
	L	L	X	X	X	X	X	X	Maintain Power Down Mode	
All Banks Idle	H	H	H	X	X	X			Refer to the Idle State section of the Current State Truth Table	3
	H	H	L	H	X	X				3
	H	H	L	L	H	X				3
	H	H	L	L	L	H	X	X	CBR Refresh	
	H	H	L	L	L	L		OP Code	Mode Register Set	4
	H	L	H	X	X	X			Refer to the Idle State section of the Current State Truth Table	3
	H	L	L	H	X	X				3
	H	L	L	L	H	X				3
	H	L	L	L	L	H	X	X	Entry Self Refresh	4
	H	L	L	L	L	L		OP Code	Mode Register Set	
L	X	X	X	X	X	X	X	Power Down	4	
Any State other than listed above	H	H	X	X	X	X	X	X	Refer to operations in the Current State Truth Table	
	H	L	X	X	X	X	X	X		Begin Clock Suspend next cycle
	L	H	X	X	X	X	X	X	Exit Clock Suspend next cycle	
	L	L	X	X	X	X	X	X	Maintain Clock Suspend	

- For the given Current State CKE must be low in the previous cycle.
- When CKE has a low to high transition, the clock and other inputs are re-enabled asynchronously. The minimum setup time for CKE (t_{CES}) must be satisfied. When exiting power down mode, a NOP command (or Device Deselect Command) is required on the first rising clock after CKE goes high.
- The address inputs (A13 - A0) depend on the command that is issued. See the Idle State section of the Current State Truth Table for more information.
- The Precharge Power Down Mode, the Self Refresh Mode, and the Mode Register Set can only be entered from the all banks idle state.
- Must be a legal command as defined in the Current State Truth Table.

Current State Truth Table (Part 1 of 3)(See note 1)

Current State	Command						Description	Action	Notes
	/CS	/RAS	/CAS	/WE	A12, A13	A11-A0			
Idle	L	L	L	L	OP Code		Mode Register Set	Set the Mode Register	2
	L	L	L	H	X	X	Auto or Self Refresh	Start Auto or Self Refresh	2,3
	L	L	H	L	BS	X	Precharge	No Operation	
	L	L	H	H	BS	Row Address	Bank Active	Activate the specified bank and row	
	L	H	L	L	BS	Column	Write	ILLEGAL	4
	L	H	L	H	BS	Column	Read	ILLEGAL	4
	L	H	H	L	X	X	Burst Termination	No Operation	
	L	H	H	H	X	X	No Operation	No Operation	
Row Active	H	X	X	X	X	X	Device Deselect	No Operation or Power Down	5
	L	L	L	L	OP Code		Mode Register Set	ILLEGAL	
	L	L	L	H	X	X	Auto or Self Refresh	ILLEGAL	
	L	L	H	L	BS	X	Precharge	Precharge	6
	L	L	H	H	BS	Row Address	Bank Active	ILLEGAL	4
	L	H	L	L	BS	Column	Write	Start Write; Determine if Auto Precharge	7,8
	L	H	L	H	BS	Column	Read	Start Read; Determine if Auto Precharge	7,8
	L	H	H	L	X	X	Burst Termination	No Operation	
Read	L	H	H	H	X	X	No Operation	No Operation	
	H	X	X	X	X	X	Device Deselect	No Operation	
	L	L	L	L	OP Code		Mode Register Set	ILLEGAL	
	L	L	L	H	X	X	Auto or Self Refresh	ILLEGAL	
	L	L	H	L	BS	X	Precharge	Terminate Burst; Start the Precharge	
	L	L	H	H	BS	Row Address	Bank Active	ILLEGAL	4
	L	H	L	L	BS	Column	Write	Terminate Burst; Start the Write cycle	8,9
	L	H	L	H	BS	Column	Read	Terminate Burst; Start a new Read cycle	8,9
Write	L	H	H	L	X	X	Burst Termination	Terminate the Burst	
	L	H	H	H	X	X	No Operation	Continue the Burst	
	H	X	X	X	X	X	Device Deselect	Continue the Burst	
	L	L	L	L	OP Code		Mode Register Set	ILLEGAL	
	L	L	L	H	X	X	Auto or Self Refresh	ILLEGAL	
	L	L	H	L	BS	X	Precharge	Terminate Burst; Start the Precharge	
	L	L	H	H	BS	Row Address	Bank Active	ILLEGAL	4
	L	H	L	L	BS	Column	Write	Terminate Burst; Start a new Write cycle	8,9
Write	L	H	L	H	BS	Column	Read	Terminate Burst; Start the Read cycle	8,9
	L	H	H	L	X	X	Burst Termination	Terminate the Burst	
	L	H	H	H	X	X	No Operation	Continue the Burst	
	H	X	X	X	X	X	Device Deselect	Continue the Burst	

1. CKE is assumed to be active (high) in the previous cycle for all entries. The Current State is the state of the bank that the Command is being applied to.
2. All Banks must be idle; otherwise, it is an illegal action.
3. If CKE is active (high) the SDRAM will start the Auto(CBR) Refresh operation, if CKE is inactive(low) than the Self Refresh mode is entered.
4. The Current State refers to only one of the banks. If BS selects this bank then the action is illegal. If BS selects the bank not being referenced by the Current State then the action may be legal depending on the state of that bank.
5. If CKE is inactive (low) then the Power Down mode is entered; otherwise there is a No Operation.
6. The minimum and maximum Active time (t_{RAS}) must be satisfied.
7. The RAS to CAS Delay (t_{RCD}) must occur before the command is given.
8. Column address A10 is used to determine if the Auto Precharge function is activated.
9. The command must satisfy any bus contention, bus turn around, and/or write recovery requirements.
10. The command is illegal if the minimum bank to bank delay time (t_{RRD}) is not satisfied.

Current State Truth Table (Part 2 of 3)(See note 1)

Current State	Command						Description	Action	Notes
	/CS	/RAS	/CAS	/WE	A12, A13	A11-A0			
Read with Auto Precharge	L	L	L	L	OP Code		Mode Register Set	ILLEGAL	
	L	L	L	H	X	X	Auto or Self Refresh	ILLEGAL	
	L	L	H	L	BS	X	Precharge	ILLEGAL	4
	L	L	H	H	BS	Row Address	Bank Active	ILLEGAL	4
	L	H	L	L	BS	Column	Write	ILLEGAL	4
	L	H	L	H	BS	Column	Read	ILLEGAL	4
	L	H	H	L	X	X	Burst Termination	ILLEGAL	
	L	H	H	H	X	X	No Operation	Continue the Burst	
Write with Auto Precharge	H	X	X	X	X	X	Device Deselect	Continue the Burst	
	L	L	L	L	OP Code		Mode Register Set	ILLEGAL	
	L	L	L	H	X	X	Auto or Self Refresh	ILLEGAL	
	L	L	H	L	BS	X	Precharge	ILLEGAL	4
	L	L	H	H	BS	Row Address	Bank Active	ILLEGAL	4
	L	H	L	L	BS	Column	Write	ILLEGAL	4
	L	H	L	H	BS	Column	Read	ILLEGAL	4
	L	H	H	L	X	X	Burst Termination	ILLEGAL	
Precharging	L	H	H	H	X	X	No Operation	Continue the Burst	
	H	X	X	X	X	X	Device Deselect	Continue the Burst	
	L	L	L	L	OP Code		Mode Register Set	ILLEGAL	
	L	L	L	H	X	X	Auto or Self Refresh	ILLEGAL	
	L	L	H	L	BS	X	Precharge	No Operation; Bank(s) idle after t _{RP}	
	L	L	H	H	BS	Row Address	Bank Active	ILLEGAL	4
	L	H	L	L	BS	Column	Write	ILLEGAL	4
	L	H	L	H	BS	Column	Read	ILLEGAL	4
Row Activating	L	H	H	L	X	X	Burst Termination	No Operation; Bank(s) idle after t _{RP}	
	L	H	H	H	X	X	No Operation	No Operation; Bank(s) idle after t _{RP}	
	H	X	X	X	X	X	Device Deselect	No Operation; Bank(s) idle after t _{RP}	
	L	L	L	L	OP Code		Mode Register Set	ILLEGAL	
	L	L	L	H	X	X	Auto or Self Refresh	ILLEGAL	
	L	L	H	L	BS	X	Precharge	ILLEGAL	4
	L	L	H	H	BS	Row Address	Bank Active	ILLEGAL	4,10
	L	H	L	L	BS	Column	Write	ILLEGAL	4
Row Activating	L	H	L	H	BS	Column	Read	ILLEGAL	4
	L	H	H	L	X	X	Burst Termination	No Operation; Row Active after t _{RCD}	
	L	H	H	H	X	X	No Operation	No Operation; Row Active after t _{RCD}	
	H	X	X	X	X	X	Device Deselect	No Operation; Row Active after t _{RCD}	

1. CKE is assumed to be active (high) in the previous cycle for all entries. The Current State is the state of the bank that the Command is being applied to.
2. All Banks must be idle; otherwise, it is an illegal action.
3. If CKE is active (high) the SDRAM will start the Auto(CBR) Refresh operation, if CKE is inactive(low) than the Self Refresh mode is entered.
4. The Current State refers to only one of the banks. If BS selects this bank then the action is illegal. If BS selects the bank not being referenced by the Current State then the action may be legal depending on the state of that bank.
5. If CKE is inactive (low) then the Power Down mode is entered; otherwise there is a No Operation.
6. The minimum and maximum Active time (t_{RAS}) must be satisfied.
7. The RAS to CAS Delay (t_{RCD}) must occur before the command is given.
8. Column address A10 is used to determine if the Auto Precharge function is activated.
9. The command must satisfy any bus contention, bus turn around, and/or write recovery requirements.
10. The command is illegal if the minimum bank to bank delay time (t_{RRD}) is not satisfied.

Current State Truth Table (Part 3of 3)(See note 1)

Current State	Command						Description	Action	Notes
	/CS	/RAS	/CAS	/WE	A12, A13	A11-A0			
Write Recovering	L	L	L	L	OP Code		Mode Register Set	ILLEGAL	
	L	L	L	H	X	X	Auto or Self Refresh	ILLEGAL	
	L	L	H	L	BS	X	Precharge	ILLEGAL	4
	L	L	H	H	BS	Row Address	Bank Active	ILLEGAL	4
	L	H	L	L	BS	Column	Write	Start Write; Determine if Auto Precharge	9
	L	H	L	H	BS	Column	Read	Start Write; Determine if Auto Precharge	9
	L	H	H	L	X	X	Burst Termination	No Operation; Row Active after t _{DPL}	
	L	H	H	H	X	X	No Operation	No Operation; Row Active after t _{DPL}	
	H	X	X	X	X	X	Device Deselect	No Operation; Row Active after t _{DPL}	
Write Recovering With Auto Precharge	L	L	L	L	OP Code		Mode Register Set	ILLEGAL	
	L	L	L	H	X	X	Auto or Self Refresh	ILLEGAL	
	L	L	H	L	BS	X	Precharge	ILLEGAL	4
	L	L	H	H	BS	Row Address	Bank Active	ILLEGAL	4
	L	H	L	L	BS	Column	Write	ILLEGAL	4,9
	L	H	L	H	BS	Column	Read	ILLEGAL	4,9
	L	H	H	L	X	X	Burst Termination	No Operation; Precharge Active after t _{DPL}	
	L	H	H	H	X	X	No Operation	No Operation; Precharge Active after t _{DPL}	
	H	X	X	X	X	X	Device Deselect	No Operation; Precharge Active after t _{DPL}	
Refreshing	L	L	L	L	OP Code		Mode Register Set	ILLEGAL	
	L	L	L	H	X	X	Auto or Self Refresh	ILLEGAL	
	L	L	H	L	BS	X	Precharge	ILLEGAL	
	L	L	H	H	BS	Row Address	Bank Active	ILLEGAL	
	L	H	L	L	BS	Column	Write	ILLEGAL	
	L	H	L	H	BS	Column	Read	ILLEGAL	
	L	H	H	L	X	X	Burst Termination	No Operation; Idle after t _{RC}	
	L	H	H	H	X	X	No Operation	No Operation; Idle after t _{RC}	
	H	X	X	X	X	X	Device Deselect	No Operation; Idle after t _{RC}	
Mode Register Accessing	L	L	L	L	OP Code		Mode Register Set	ILLEGAL	
	L	L	L	H	X	X	Auto or Self Refresh	ILLEGAL	
	L	L	H	L	BS	X	Precharge	ILLEGAL	
	L	L	H	H	BS	Row Address	Bank Active	ILLEGAL	
	L	H	L	L	BS	Column	Write	ILLEGAL	
	L	H	L	H	BS	Column	Read	ILLEGAL	
	L	H	H	L	X	X	Burst Termination	ILLEGAL	
	L	H	H	H	X	X	No Operation		
H	X	X	X	X	X	Device Deselect			

64Mb : x8 x16
PC133 / PC100 Synchronous DRAM

1. CKE is assumed to be active (high) in the previous cycle for all entries. The Current State is the state of the bank that the Command is being applied to.
2. All Banks must be idle; otherwise, it is an illegal action.
3. If CKE is active (high) the SDRAM will start the Auto(CBR) Refresh operation, if CKE is inactive(low) than the Self Refresh mode is entered.
4. The Current State refers to only one of the banks. If BS selects this bank then the action is illegal. If BS selects the bank not being referenced by the Current State then the action may be legal depending on the state of that bank.
5. If CKE is inactive (low) then the Power Down mode is entered; otherwise there is a No Operation.
6. The minimum and maximum Active time (t_{RAS}) must be satisfied.
7. The RAS to CAS Delay (t_{RCD}) must occur before the command is given.
8. Column address A10 is used to determine if the Auto Precharge function is activated.
9. The command must satisfy any bus contention, bus turn around, and/or write recovery requirements.
10. The command is illegal if the minimum bank to bank delay time (t_{RRD}) is not satisfied.

DEVICE OPERATIONS

Power On and Initialization

The default power on state of the mode register is supplier specific and may be undefined. The following power on and initialization sequence guarantees the device is preconditioned to each users specific needs.

Like a conventional DRAM, the Synchronous DRAM must be powered up and initialized in a predefined manner. During power on, all VDD and VDDQ pins must be built up simultaneously to the specified voltage when the input signals are held in the "NOP" state. The power on voltage must not exceed $VDD+0.3V$ on any of the input pins or VDD supplies. The CLK signal must be started at the same time. After power on, an initial pause of 200 μ s is required followed by a precharge of all banks using the precharge command. To prevent data contention on the DQ bus during power on, it is required that the DQM and CKE pins be held high during the initial pause period. Once all banks have been precharged, the Mode Register Set Command must be issued to initialize the Mode Register. A minimum of eight Auto Refresh cycles (CBR) are also required. These may be done before or after programming the Mode Register. Failure to follow these steps may lead to unpredictable start-up modes.

Programming the Mode Register

For application flexibility, /CAS latency, burst length, burst sequence, and operation type are user defined variables and must be programmed into the SDRAM Mode Register with a single Mode Register Set Command. Any content of the Mode Register can be altered by re-executing the Mode Register Set Command. If the user chooses to modify only a subset of the Mode Register variables, all four variables must be redefined when the Mode Register Set Command is issued.

After initial power up, the Mode Register Set Command must be issued before read or write cycles may begin. All banks must be in a precharged state and CKE must be high at least one cycle before the Mode Register Set Command can be issued. The Mode Register Set Command is activated by the low signals of /RAS, /CAS, /CS, and /WE at the positive edge of the clock. The address input data during this cycle defines the parameters to be set as shown in the Mode Register Operation table. A new command may be issued following the mode register set command once a delay equal to tRSC has elapsed.

/CAS Latency

The /CAS latency is a parameter that is used to define the delay from when a Read Command is registered on a rising clock edge to when the data from that Read Command becomes available at the outputs. The /CAS latency is expressed in terms of clock cycles and can have a value of 2 or 3 cycles. The value of the /CAS latency is determined by the speed grade of the device and the clock frequency that is used in the application. A table showing the relationship between the /CAS latency, speed grade, and clock frequency appears in the Electrical Characteristics section of this document. Once the appropriate /CAS latency has been selected it must be programmed into the mode register after power up, for an explanation of this procedure see Programming the Mode Register in the previous section.



Mode Register Definition

Mode Register set: (Programming mode)

A13	A12	A11	A10	A9	A8	A7	A6	A5	A4	A3	A2	A1	A0	Address bus (Ax)
Operation Mode						CAS Latency			BT	Burst Length			Mode Register (Mx)	

CAS Latency				Burst Type		Burst Length				
M6	M5	M4	Latency	M3	Type	M2	M1	M0	BT=0	BT=1
0	0	0	Reserved	0	Sequential	0	0	0	1	1
0	0	1	Reserved	1	Interleave	0	0	1	2	2
0	1	0	2	0		1	0	4	4	
0	1	1	3	0		1	1	8	8	
1	0	0	Reserved	1		0	0	Reserved	Reserved	
1	0	1	Reserved	1	0	1	Reserved	Reserved		
1	1	0	Reserved	1	1	0	Reserved	Reserved		
1	1	1	Reserved	1	1	1	Full Page	Reserved		

Operation Mode							
M13	M12	M11	M10	M9	M8	M7	Mode
0	0	0	0	0	0	0	Normal
0	0	0	0	1	0	0	Multiple Burst with Single Write

Burst Mode Operation

Burst mode operation is used to provide a constant flow of data to memory locations (write cycle), or from memory locations (read cycle). Three parameters define how the burst mode will operate: burst sequence, burst length, and operation mode. The burst sequence and burst length are programmable and are determined by address bits A0 - A3 during the Mode Register Set command. Operation mode is also programmable and is set by address bits A7 - A13.

Burst sequence defines the order in which the burst data will be delivered or stored to the SDRAM. The two types of burst sequence supported are sequential and interleaved. See the table below.

The burst length controls the number of bits that will be output after a Read Command, or the number of bits to be input after a Write Command. The burst length can be programmed to have values of 1, 2, 4, 8 or full page (actual page length is dependent on organization: x4, x8, or x16). Full page burst operation is only possible using the sequential burst type.

Burst operation mode can be normal operation or multiple burst with single write operation. Normal operation implies that the device will perform burst operations on both read and write cycles until the desired burst length is satisfied. Multiple burst with single write operation was added to support Write Through Cache operation. Here, the programmed burst length only applies to read cycles. All write cycles are single write operations when this mode is selected.



Burst Length and Sequence

Burst Length	Starting Bit			Interleave	Sequential
2	A0				
	0			0-1	0-1
	1			1-0	1-0
4	A1	A0			
	0	0		0-1-2-3	0-1-2-3
	0	1		1-0-3-2	1-2-3-0
	1	0		2-3-0-1	2-3-0-1
	1	1		3-2-1-0	3-0-1-2
8	A2	A1	A0		
	0	0	0	0-1-2-3-4-5-6-7	0-1-2-3-4-5-6-7
	0	0	1	1-0-3-2-5-4-7-6	1-2-3-4-5-6-7-0
	0	1	0	2-3-0-1-6-7-4-5	2-3-4-5-6-7-0-1
	0	1	1	3-2-1-0-7-6-5-4	3-4-5-6-7-0-1-2
	1	0	0	4-5-6-7-0-1-2-3	4-5-6-7-0-1-2-3
	1	0	1	5-4-7-6-1-0-3-2	5-6-7-0-1-2-3-4
	1	1	0	6-7-4-5-2-3-0-1	6-7-0-1-2-3-4-5
	1	1	1	7-6-5-4-3-2-1-0	7-0-1-2-3-4-5-6
Full Page (Note)	n	n	n	Not supported	Cn, Cn+1, Cn+2,.....

Note : Page length is a function of I/O organization and column addressing.

X 8 organization (CA0-CA8); Page Length = 512 bits

X16 organization (CA0-CA7); Page Length = 256 bits

Bank Activate Command

In relation to the operation of a fast page mode DRAM, the Bank Activate command corresponds to a falling /RAS signal. The Bank Activate command is issued by holding /CAS and /WE high with /CS and /RAS low at the rising edge of the clock. The bank select address A12 - A13 is used to select the desired bank. The row address A0 - A11 is used to determine which row to activate in the selected bank. Activation of banks within both decks of a 2-high stacked device is allowed.

The Bank Activate command must be applied before any Read or Write operation can be executed. The delay from when the Bank Activate command is applied to when the first read or write operation can begin must meet or exceed the /RAS to /CAS delay time (tRCD). Once a bank has been activated, it must be precharged before another Bank Activate command can be applied to the same bank. The minimum time interval between successive Bank Activate commands to the same bank is determined by the RAS cycle time of the device (tRC). The minimum time interval between interleaved Bank Activate commands (Bank A to Bank B and vice versa) is the Bank to Bank delay time (tRRD). The maximum time that each bank can be held active is specified as tRAS(max).

Bank Activate Command Cycle

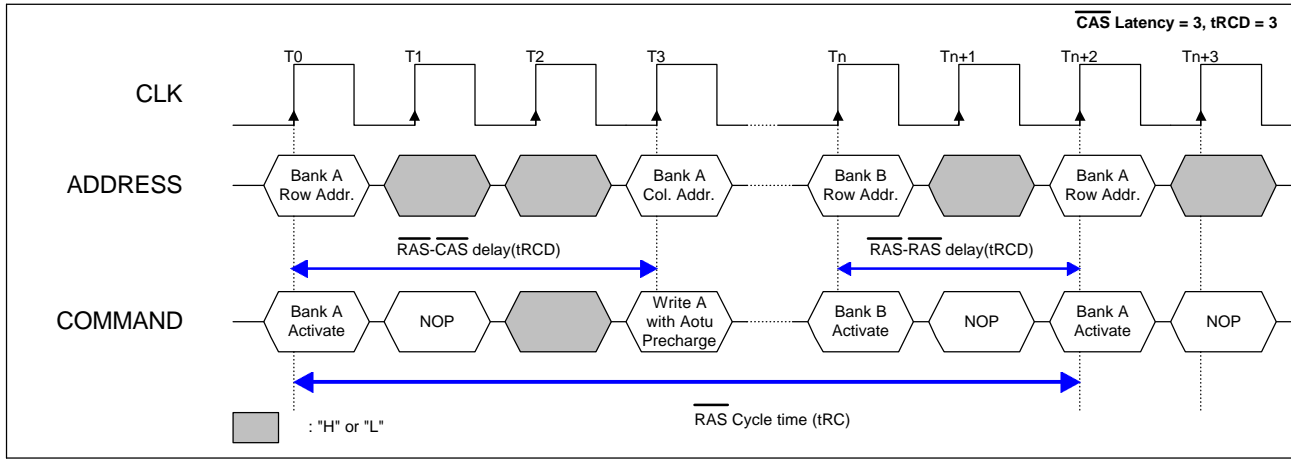

Bank Select

The Bank Select inputs, BS0 and BS1, determine the bank to be used during a Bank Activate, Precharge, Read, or Write operation.

Bank Selection Bits

BS0	BS1	Bank
0	0	Bank 0
0	1	Bank 1
1	0	Bank 2
1	1	Bank 3

Read and Write Access Modes

After a bank has been activated, a read or write cycle can be executed. This is accomplished by setting /RAS high and /CAS low at the clock's rising edge after the necessary /RAS to /CAS delay (tRCD). /WE must also be defined at this time to determine whether the access cycle is a read operation (/WE high), or a write operation (/WE low). The address inputs determine the starting column address.

The SDRAM provides a wide variety of fast access modes. A single Read or Write Command will initiate a serial read or write operation on successive clock cycles at data rates of up to 147 MHz. The number of serial data bits for each access is equal to the burst length, which is programmed into the Mode Register. If the burst length is full page, data is repeatedly read out or written until a Burst Stop or Precharge Command is issued.

Similar to Page Mode of conventional DRAMs, a read or write cycle can not begin until the sense amplifiers latch the selected row address information. The refresh period (tREF) is what limits the number of random column accesses to an activated bank. A new burst access can be done even before the previous burst ends. The ability to interrupt a burst operation at every clock cycle is supported; this is referred to as the 1-N rule. When the previous burst is interrupted by another Read or Write Command, the remaining addresses are overridden by the new address.

Precharging an active bank after each read or write operation is not necessary, providing the same row is to be accessed again. To perform a read or write cycle to a different row within an activated bank, the bank must be precharged and a new Bank Activate command must be issued. When more than one bank is activated, interleaved (ping pong) bank Read or Write operations are possible. By using the programmed burst length and alternating the access and precharge operations between multiple banks, fast and seamless data access operation among many different pages can be realized. When multiple banks are activated, column to column interleave operation can be done between different pages. Finally, Read or Write Commands can be issued to the same bank or between active banks on every clock cycle.

Burst Read Command

The Burst Read command is initiated by having /CS and /CAS low while holding /RAS and /WE high at the rising edge of the clock. The address inputs determine the starting column address for the burst. The Mode Register sets the type of burst (sequential or interleave) and the burst length (1, 2, 4, 8, full page). The delay from the start of the command to when the data from the first cell appears on the outputs is equal to the value of the /CAS latency that is set in the Mode Register.

Burst Read Operation

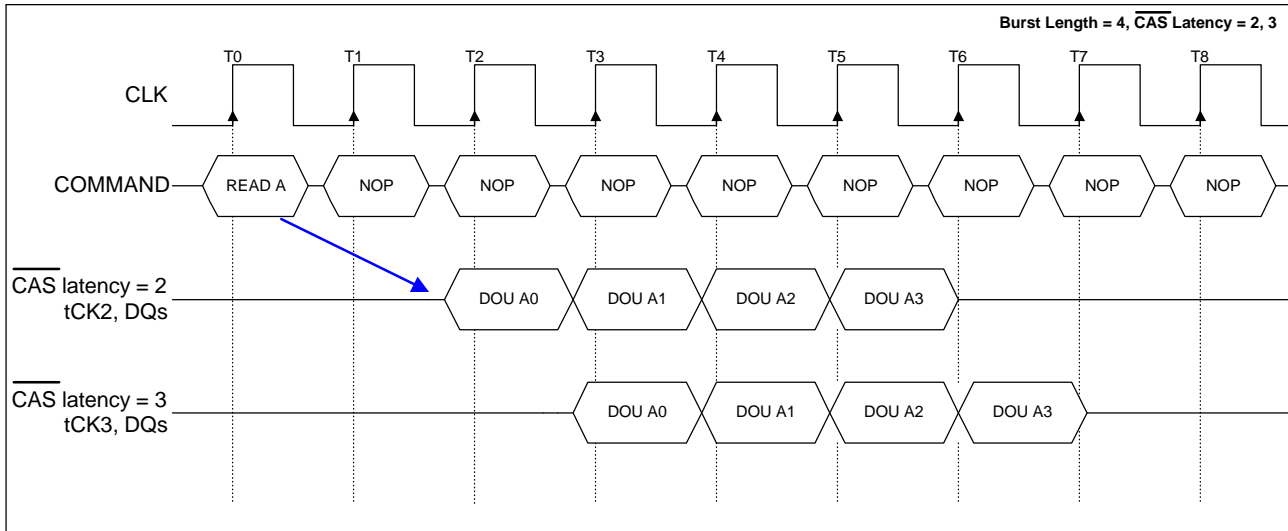

Read Interrupted by a Read

A Burst Read may be interrupted before completion of the burst by another Read Command, with the only restriction being that the interval that separates the commands must be at least one clock cycle. When the previous burst is interrupted, the remaining addresses are overridden by the new address with the full burst length. The data from the first Read Command continues to appear on the outputs until the /CAS latency from the interrupting Read Command is satisfied, at this point the data from the interrupting Read Command appears.

Read Interrupted by a Read

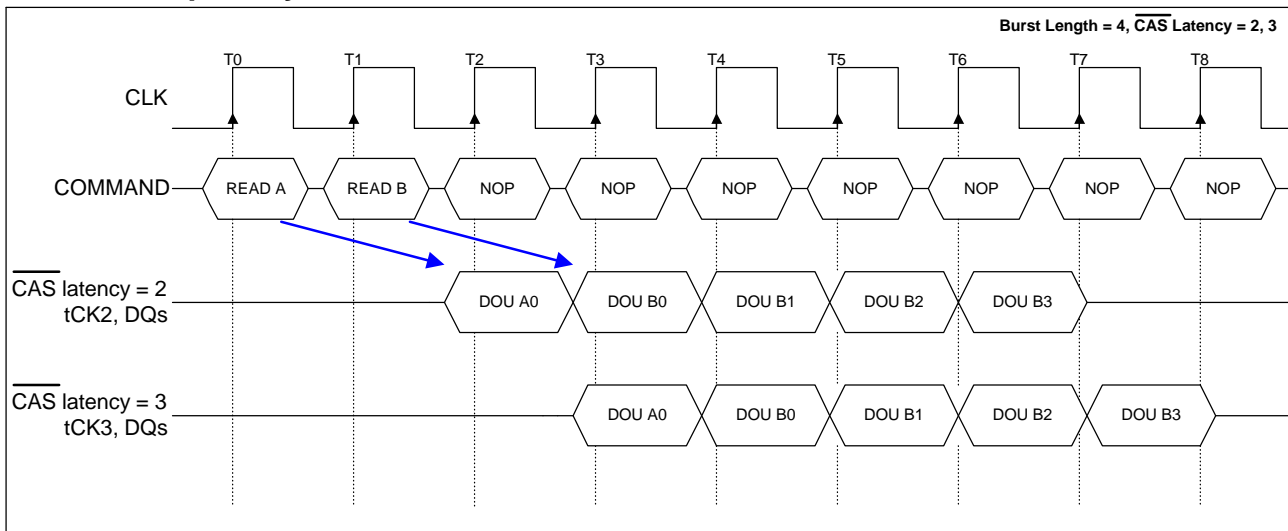

Read Interrupted by a Write

To interrupt a burst read with a Write Command, DQM may be needed to place the DQs (output drivers) in a high impedance state to avoid data contention on the DQ bus. If a Read Command will issue data on the first and second clocks cycles of the write operation, DQM is needed to insure the DQs are tri-stated. After that point the Write Command will have control of the DQ bus.

Minimum Read to Write Interval

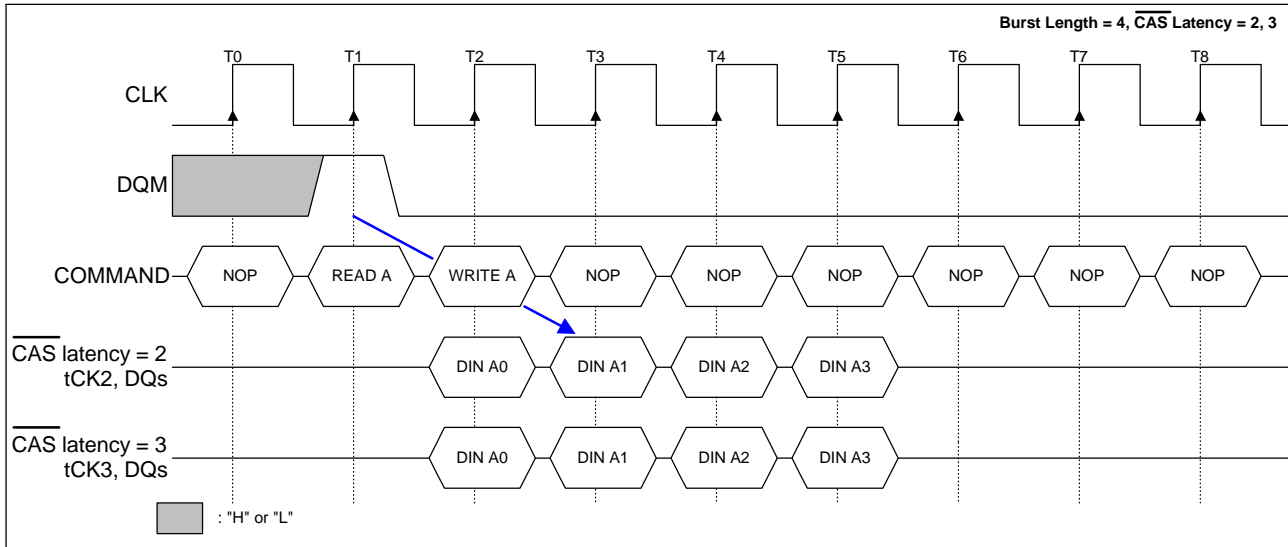

Non-Minimum Read to Write Interval

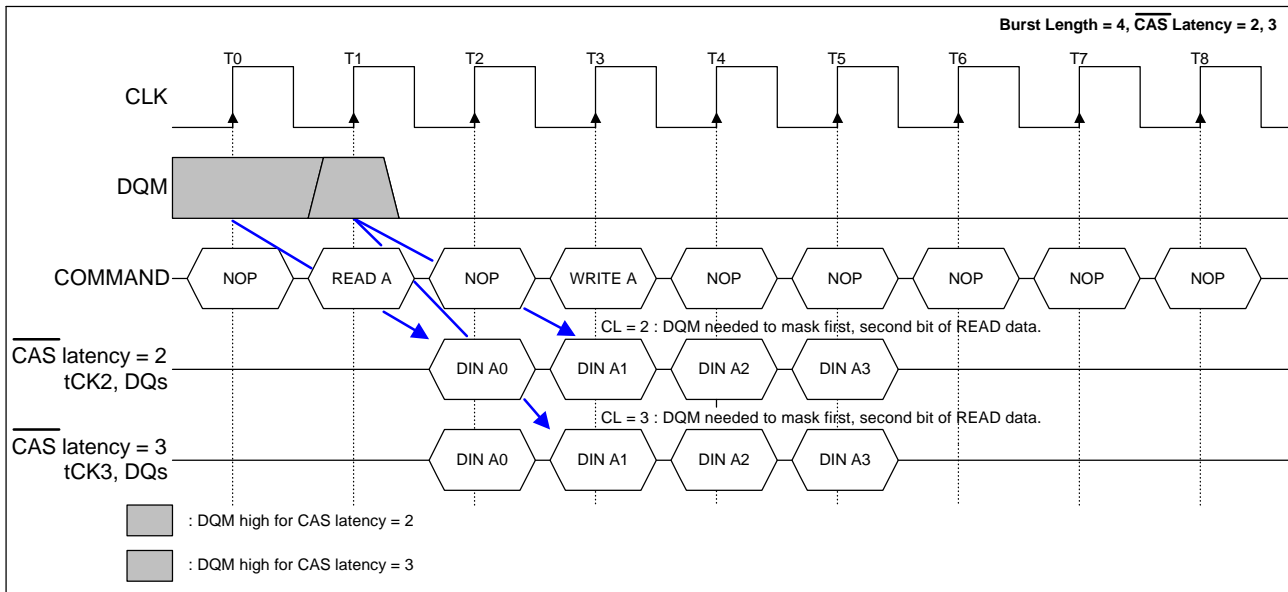

**64Mb : x8 x16
PC133 / PC100 Synchronous DRAM**

Burst Write Command

The Burst Write command is initiated by having /CS, /CAS, and /WE low while holding /RAS high at the rising edge of the clock. The address inputs determine the starting column address. There is no /CAS latency required for burst write cycles. Data for the first burst write cycle must be applied on the DQ pins on the same clock cycle that the Write Command is issued. The remaining data inputs must be supplied on each subsequent rising clock edge until the burst length is completed. When the burst has finished, any additional data supplied to the DQ pins will be ignored.

Burst Write Operation

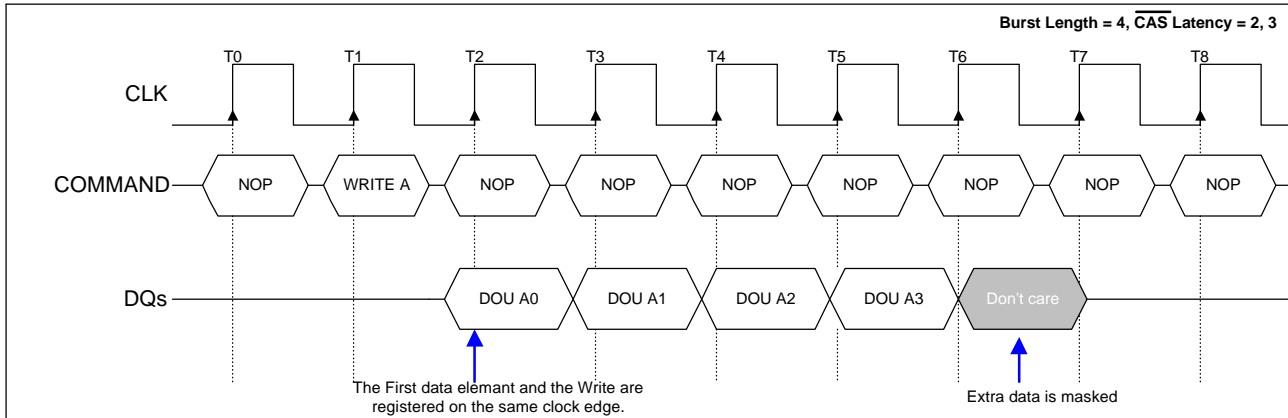

Write Interrupted by a Write

A burst write may be interrupted before completion of the burst by another Write Command. When the previous burst is interrupted, the remaining addresses are overridden by the new address and data will be written into the device until the programmed burst length is satisfied.

Write Interrupted by a Write

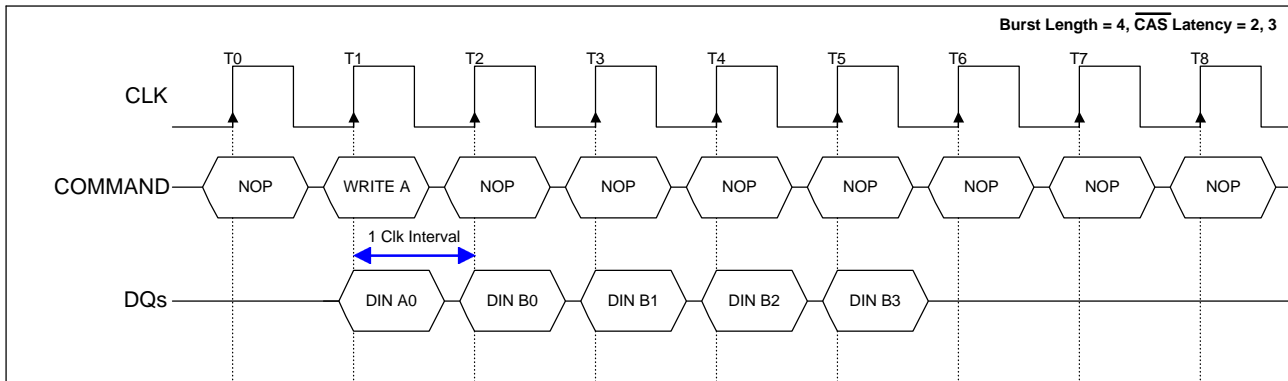

Write Interrupted by a Read

A Read Command will interrupt a burst write operation on the same clock cycle that the Read Command is registered. The DQs must be in the high impedance state at least one cycle before the interrupting read data appears on the outputs to avoid data contention. When the Read Command is registered, any residual data from the burst write cycle will be ignored. Data that is presented on the DQ pins before the Read Command is initiated will actually be written to the memory.

Minimum Write to Read Interval

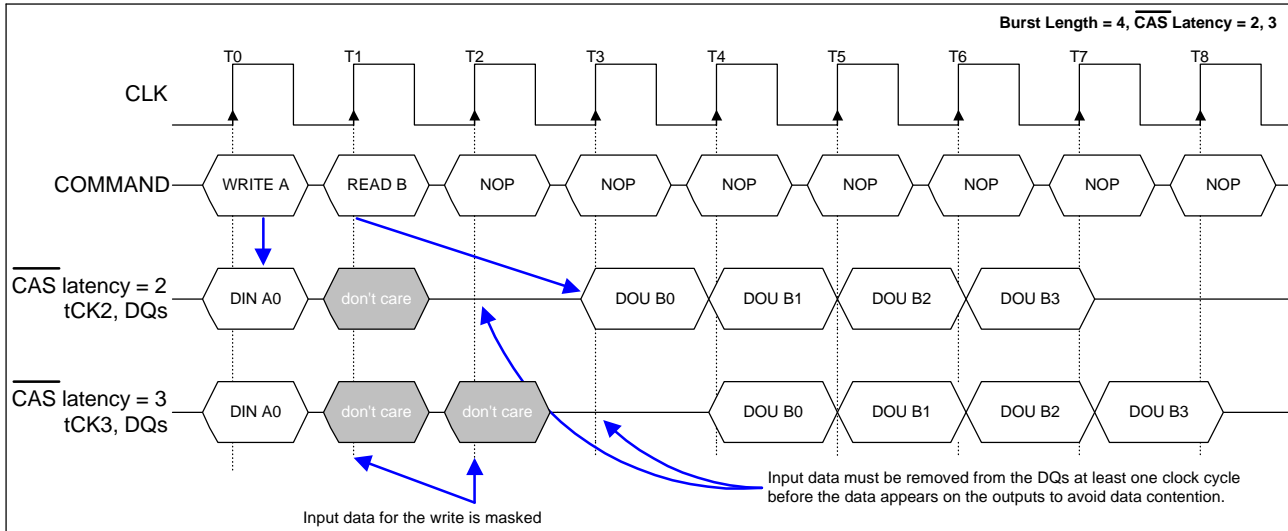

Non-Minimum Write to Read Interval

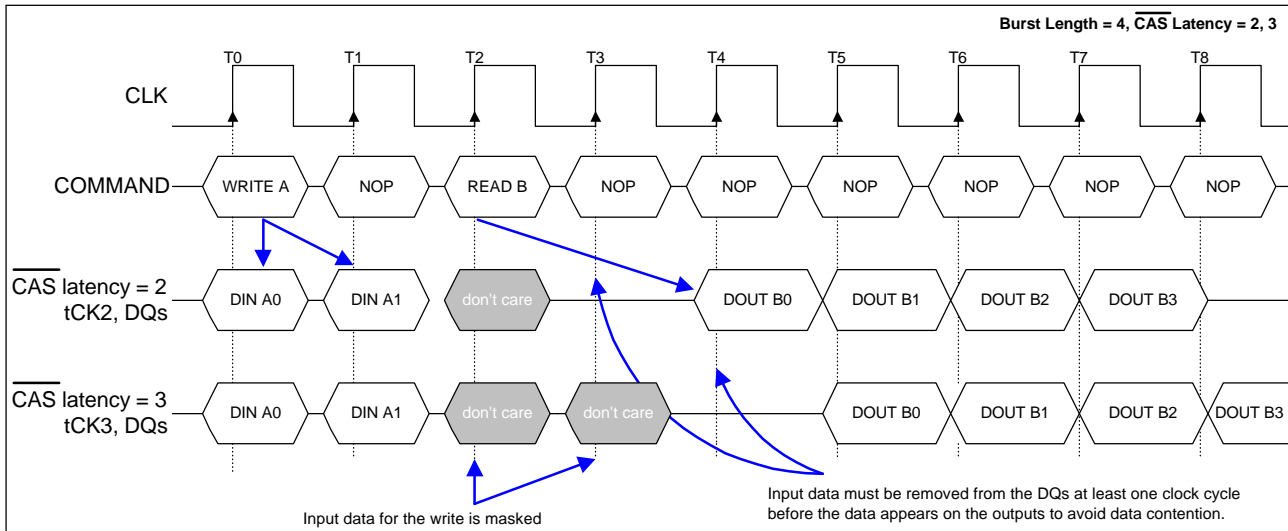



Burst Stop Command

Once a burst read or write operation has been initiated, there exist several methods in which to terminate the burst operation prematurely. These methods include using another Read or Write Command to interrupt an existing burst operation or using a Precharge Command to interrupt a burst cycle and close the active bank. When interrupting a burst with another Read or Write Command care must be taken to avoid DQ contention.

If the burst length is full page, the Burst Stop Command may also be used to terminate the existing burst operation but leave the bank open for future Read or Write Commands to the same page of the active bank. Use of the Burst Stop Command during other burst length operations is illegal. The Burst Stop Command is defined by having /RAS and /CAS high with /CS and /WE low at the rising edge of the clock.

When using the Burst Stop Command during a burst read cycle, the data DQs go to a high impedance state after a delay which is equal to the /CAS Latency set in the Mode Register.

Termination of a Burst Read Operation

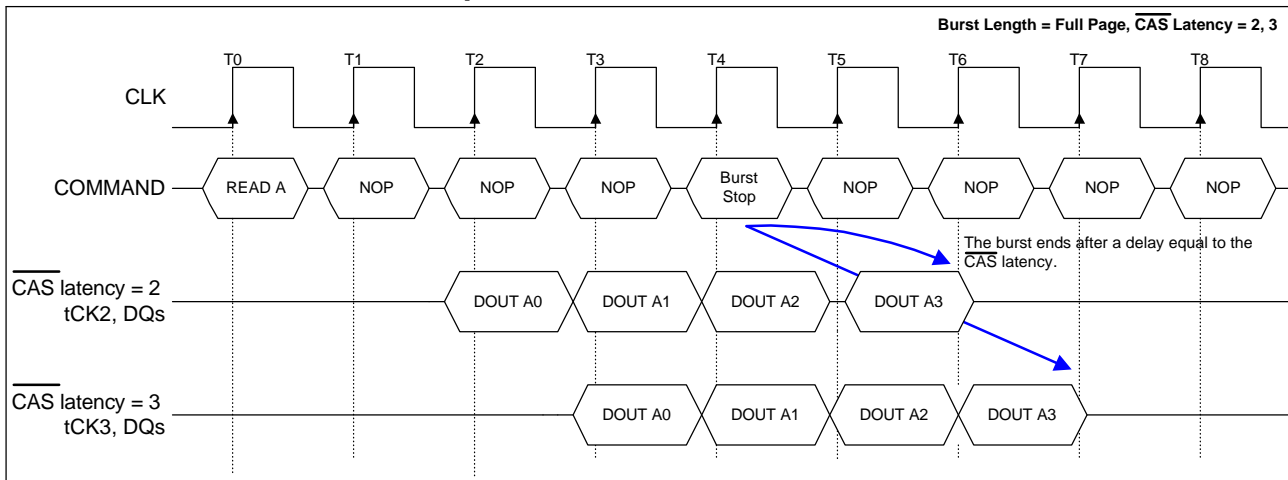

If a Burst Stop Command is issued during a full page burst write operation, then any residual data from the burst write cycle will be ignored. Data that is presented on the DQ pins before the Burst Stop Command is registered will be written to the memory.

Termination of a Burst Write Operation

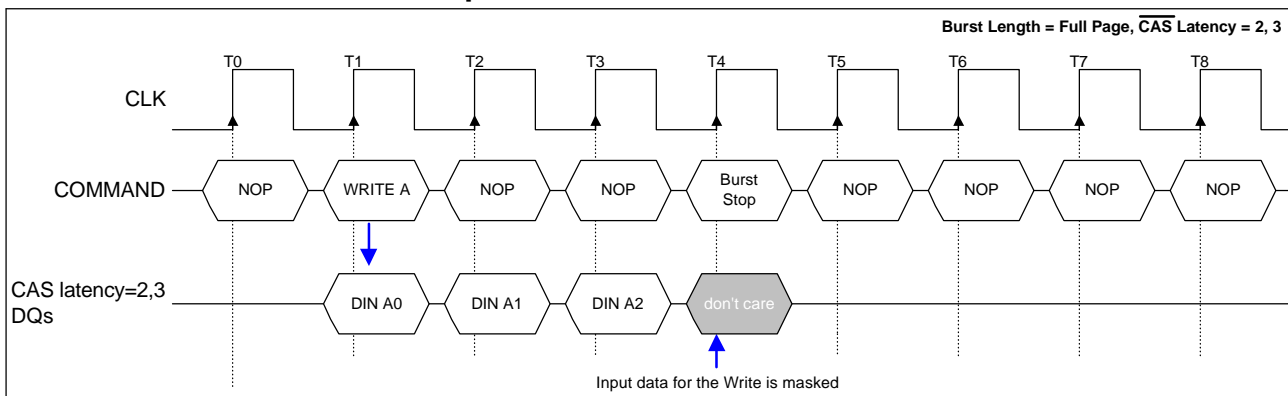

**64Mb : x8 x16
PC133 / PC100 Synchronous DRAM**

Auto-Precharge Operation

Before a new row in an active bank can be opened, the active bank must be precharged using either the Precharge Command or the auto-precharge function. When a Read or a Write Command is given to the SDRAM, the /CAS timing accepts one extra address, column address A10, to allow the active bank to automatically begin precharge at the earliest possible moment during the burst read or write cycle. If A10 is low when the Read or Write Command is issued, then normal Read or Write burst operation is executed and the bank remains active at the completion of the burst sequence. If A10 is high when the Read or Write Command is issued, then the auto-precharge function is engaged. During auto-precharge, a Read Command will execute as normal with the exception that the active bank will begin to precharge before all burst read cycles have been completed. Regardless of burst length, the precharge will begin (/CAS latency - 1) clocks prior to the last data output. Auto-precharge can also be implemented during Write commands.

A Read or Write Command without auto-precharge can be terminated in the midst of a burst operation. However, a Read or Write Command with auto-precharge can not be interrupted by a command to the same bank. Therefore use of a Read, Write, or Precharge Command to the same bank is prohibited during a read or write cycle with auto-precharge until the entire burst operation is completed. Once the precharge operation has started the bank cannot be reactivated until the Precharge time (tRP) has been satisfied. It should be noted that the device will not respond to the Auto-Precharge command if the device is programmed for full page burst read or write cycles, or full page burst read cycles with single write operation.

When using the Auto-Precharge Command, the interval between the Bank Activate Command and the beginning of the internal precharge operation must satisfy tRAS(min). If this interval does not satisfy tRAS(min) then tRCD must be extended.

Burst Read with Auto-Precharge

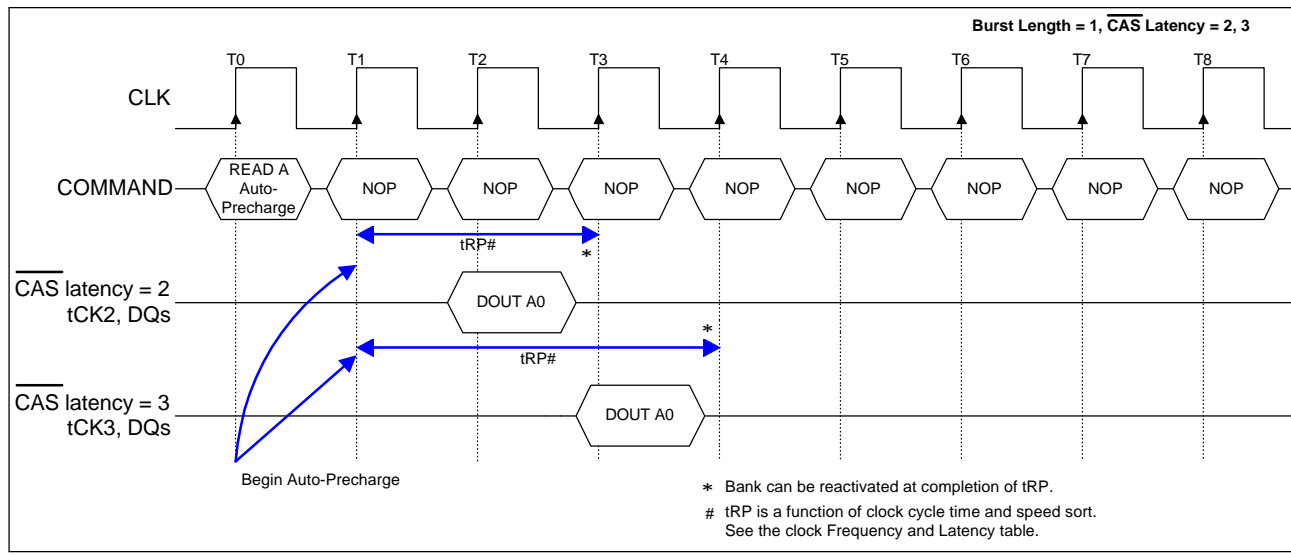

Burst Read with Auto-Precharge

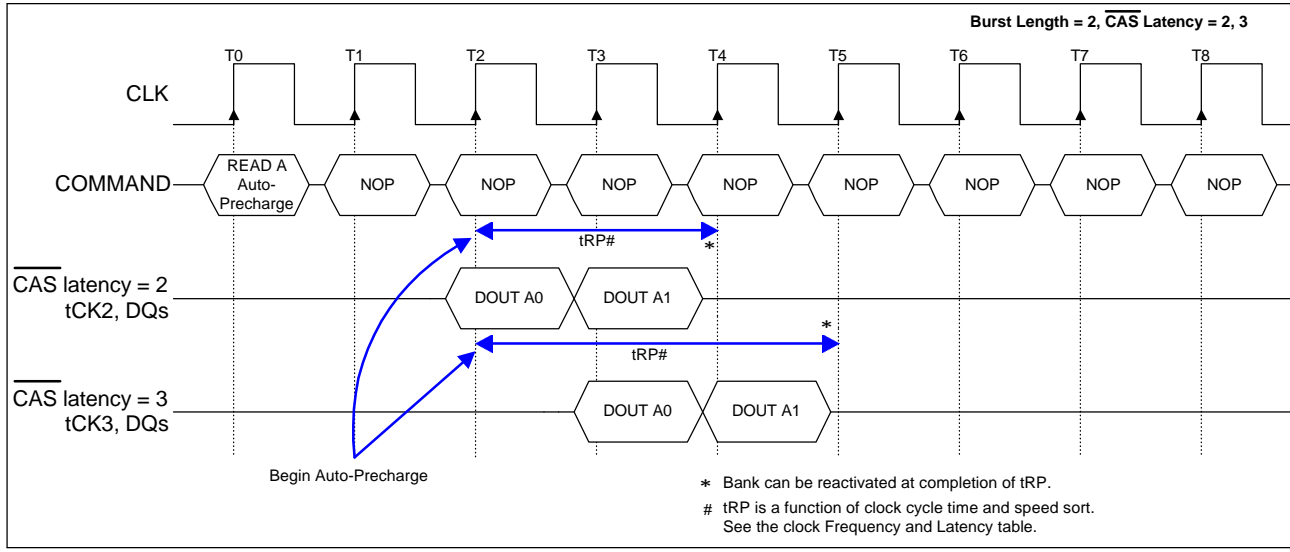

Burst Read with Auto-Precharge

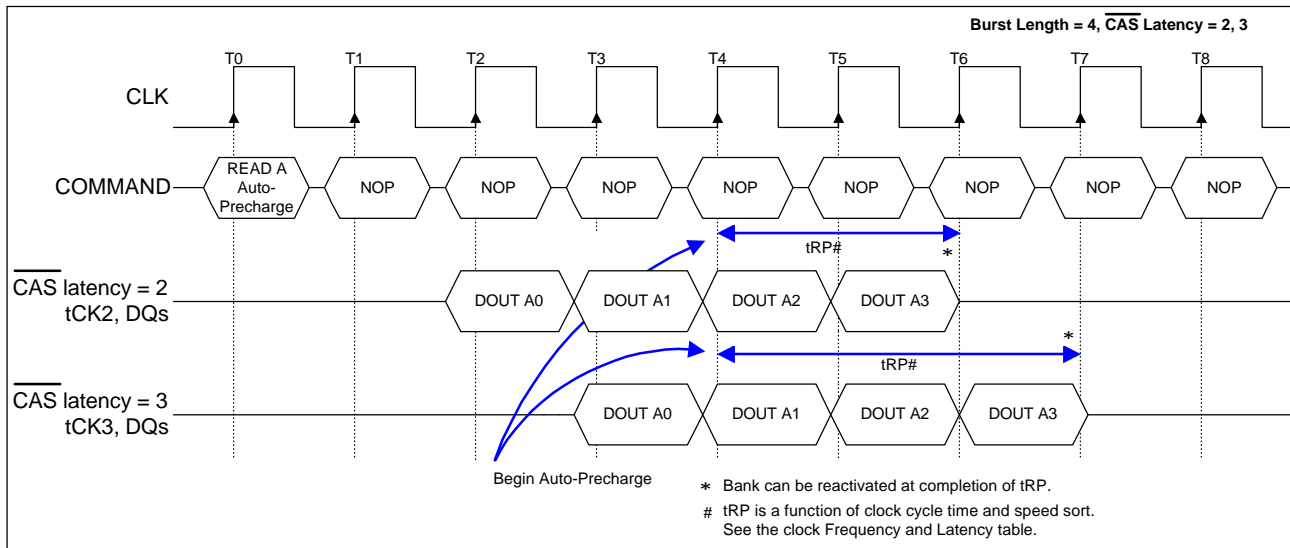



Although a Read Command with auto-precharge cannot be interrupted by a command to the same bank, it can be interrupted by a Read or Write Command to a different bank. If the interrupting command is issued before auto-precharge begins then the precharge function will begin with the new command. The bank being auto-precharged may be reactivated after the delay tRP.

Burst Read with Auto-Precharge Interrupted by Read

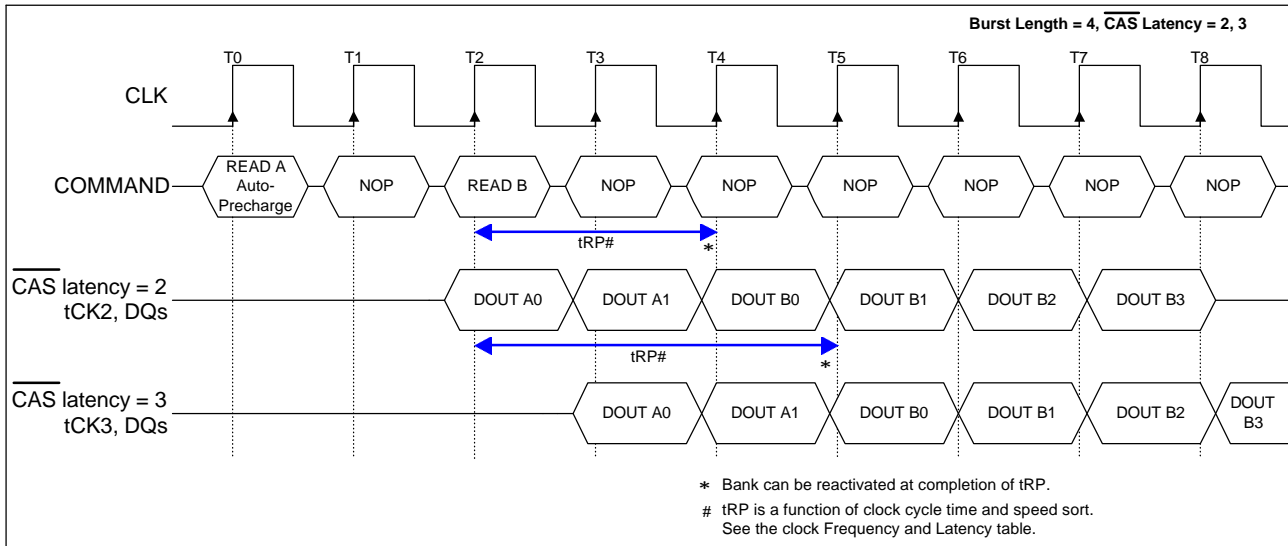

If interrupting a Read Command with auto-precharge with a Write Command, DQM must be used to avoid DQ contention.

Burst Read with Auto-Precharge Interrupted by Write

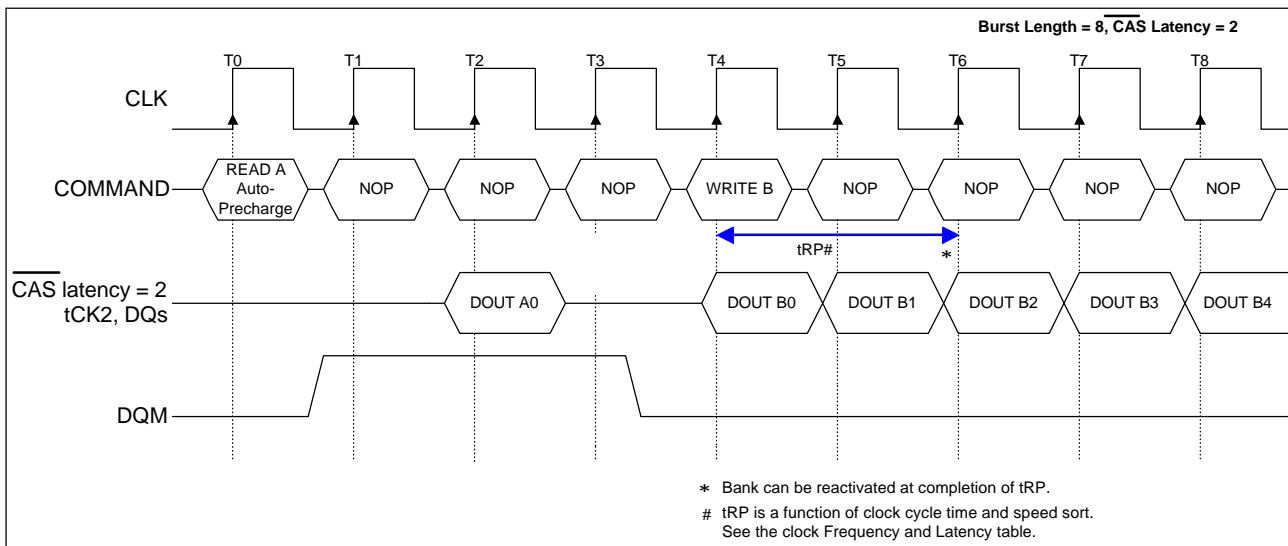

If A10 is high when a Write Command is issued, the Write with Auto-Precharge function is initiated. The bank undergoing auto-precharge can not be reactivated until tDAL, Data-in to Active delay, is satisfied.

Burst Write with Auto-Precharge

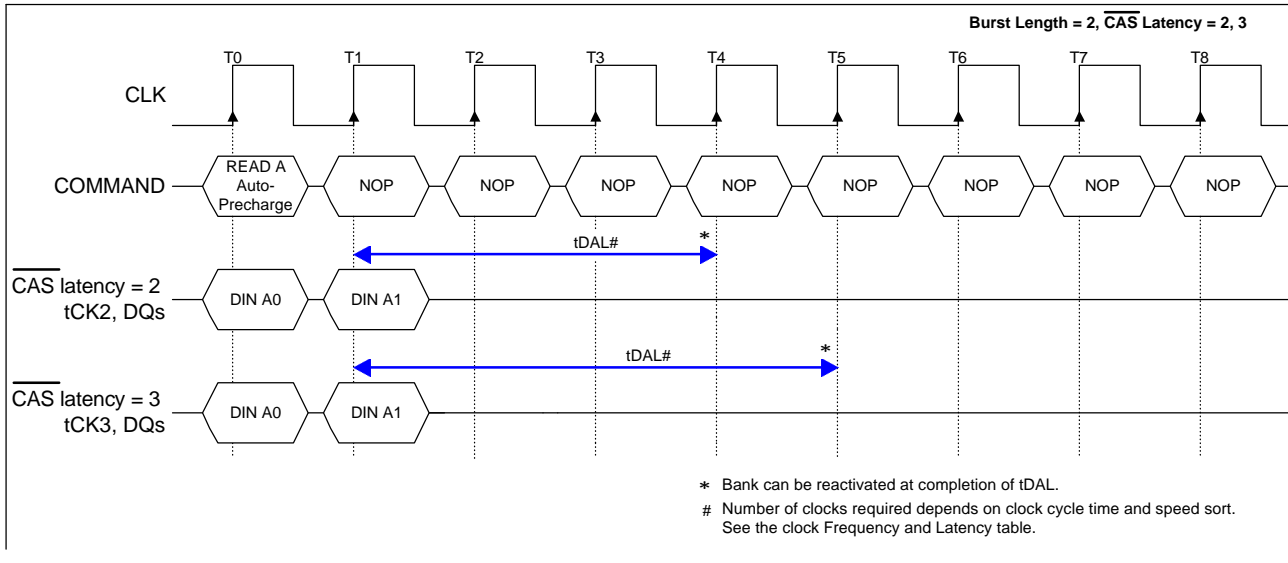

Similar to the Read Command, a Write Command with auto-precharge can not be interrupted by a command to the same bank. It can be interrupted by a Read or Write Command to a different bank, however. The precharge function will begin with the new command. The bank may be reactivated after t_{RP} is satisfied.

Burst Write with Auto-Precharge Interrupted by Write

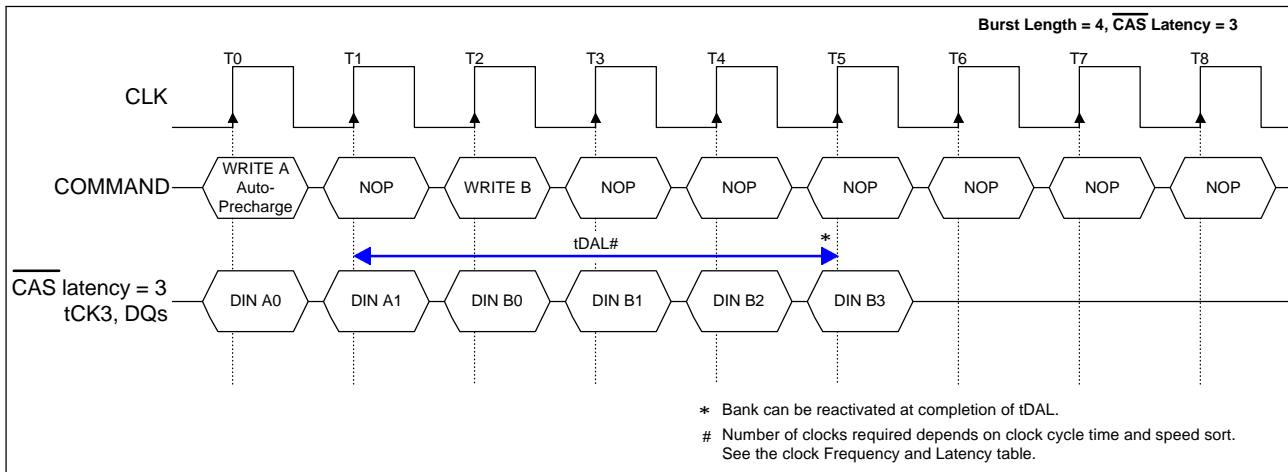



Burst Write with Auto-Precharge Interrupted by Read

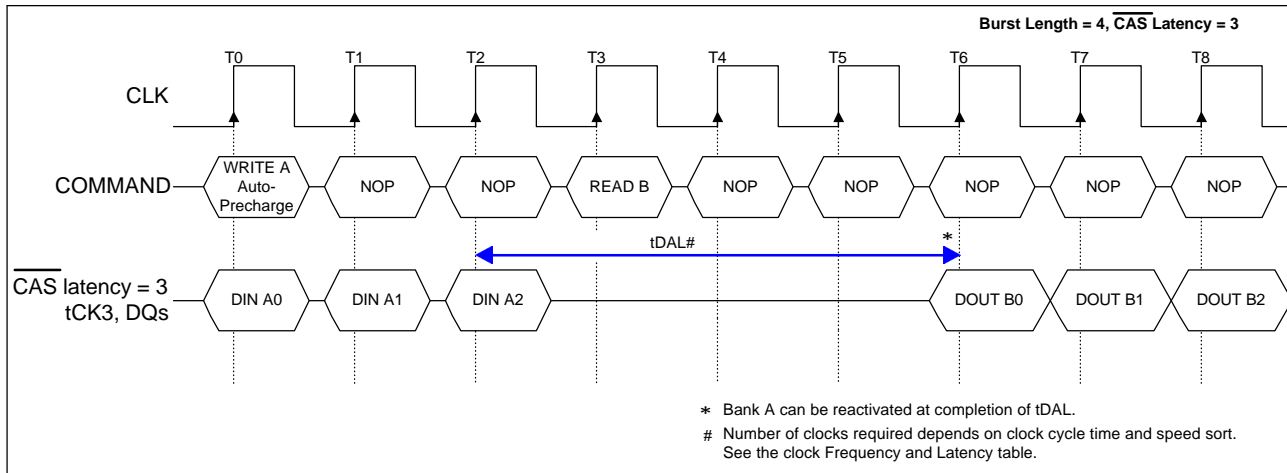

Precharge Command

The Precharge Command is used to precharge or close a bank that has been activated. The Precharge Command is triggered when /CS, /RAS, and /WE are low and /CAS is high at the rising edge of the clock. The Precharge Command can be used to precharge each bank separately or all banks simultaneously. Three address bits--A10, A12, and A13--are used to define which bank(s) is to be precharged when the command is issued.

Bank Selection for Precharge by Address Bits

A10	Bank Select	Precharged Bank(s)
LOW	BS0, BS1	Bank defined by BS0, BS1 only
HIGH	DON'T CARE	All Banks

For read cycles, the Precharge Command may be applied (/CAS latency - 1) clocks prior to the last data output. For write cycles, a delay must be satisfied from the start of the last burst write cycle until the Precharge Command can be issued. This delay is known as tDPL, Data-in to Precharge delay.

After the Precharge Command is issued, the precharged bank must be reactivated before a new read or write access can be executed. The delay between the Precharge Command and the Activate Command must be greater than or equal to the Precharge time (tRP).



Burst Read followed by the Precharge Command

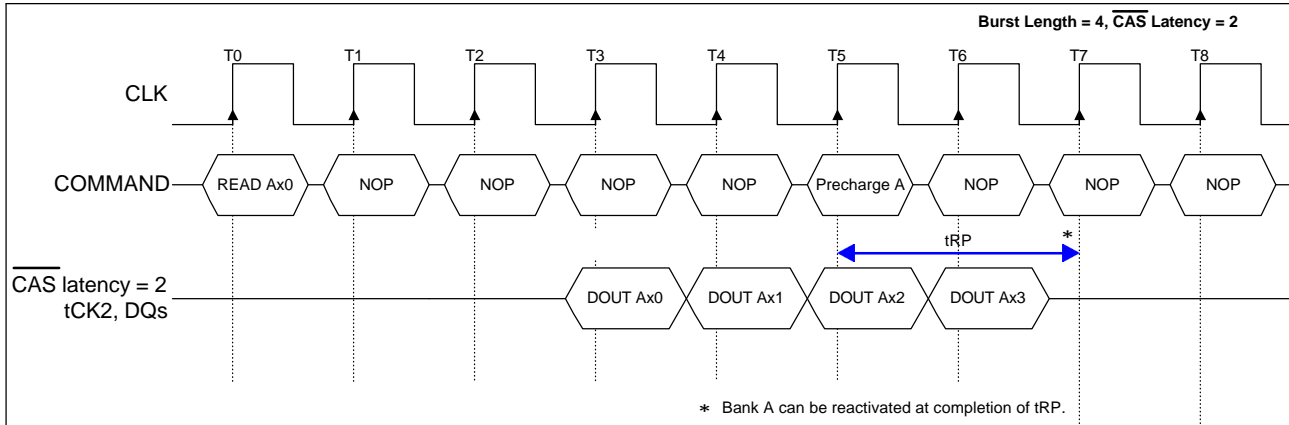

Burst Write followed by the Precharge Command

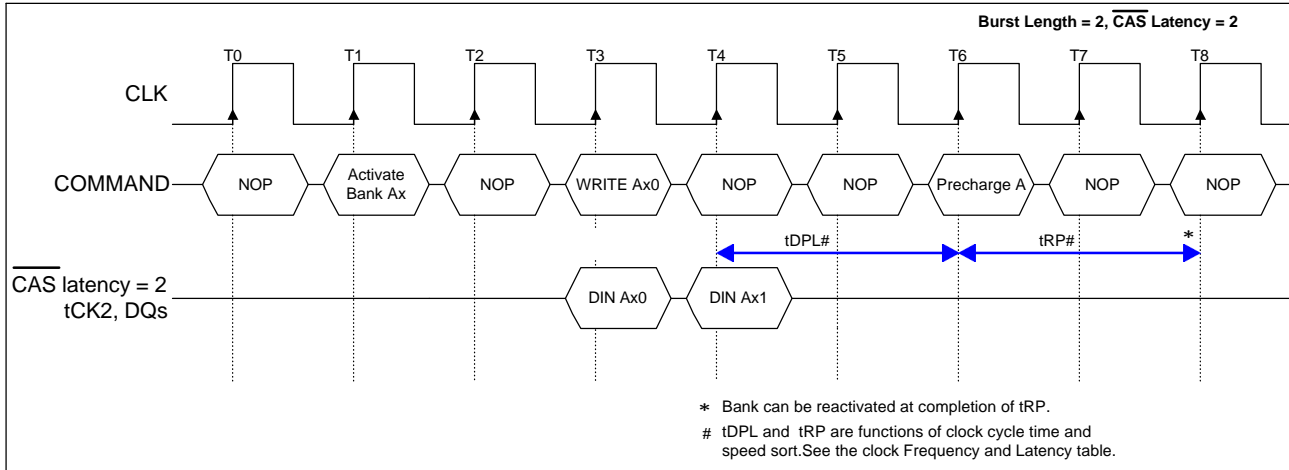



Precharge Termination

The Precharge Command may be used to terminate either a burst read or burst write operation. When the Precharge command is issued, the burst operation is terminated and bank precharge begins. For burst read operations, valid data will continue to appear on the data bus as a function of /CAS Latency.

Burst Read Interrupted by Precharge

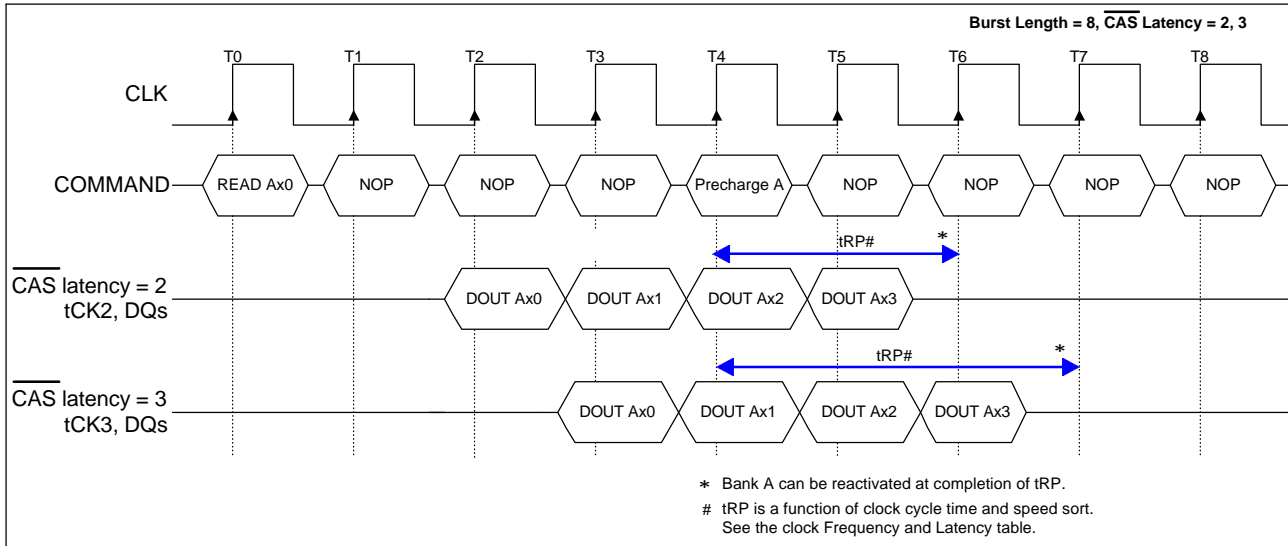

Burst write operations will be terminated by the Precharge command. The last write data that will be properly stored in the device is that write data that is presented to the device a number of clock cycles prior to the Precharge command equal to the Data-in to Precharge delay, tDPL.

Precharge Termination of a Burst Write

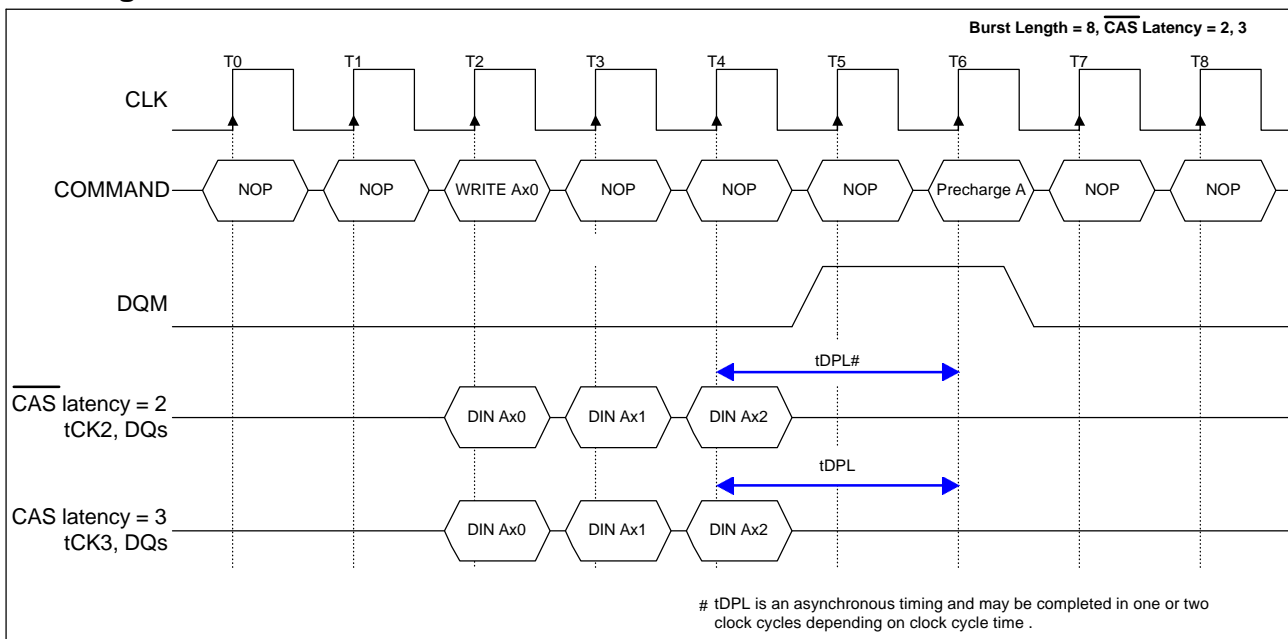

Automatic Refresh Command (/CAS before /RAS Refresh)

When /CS, /RAS, and /CAS are held low with CKE and /WE high at the rising edge of the clock, the chip enters the Automatic Refresh mode (CBR). All banks of the SDRAM must be precharged and idle for a minimum of the Precharge time (tRP) before the Auto Refresh Command (CBR) can be applied. For a stacked device, both decks may be refreshed at the same time using Automatic Refresh Mode. An address counter, internal to the device provides the address during the refresh cycle. No control of the external address pins is required once this cycle has started.

When the refresh cycle has completed, all banks of the SDRAM will be in the precharged (idle) state. A delay between the Auto Refresh Command (CBR) and the next Activate Command or subsequent Auto Refresh Command must be greater than or equal to the /RAS cycle time (tRC).

Self Refresh Command

The SDRAM device has a built-in timer to accommodate Self Refresh operation. The Self Refresh Command is defined by having /CS, /RAS, /CAS, and CKE held low with /WE high at the rising edge of the clock. All banks must be idle prior to issuing the Self Refresh Command. Once the command is registered, CKE must be held low to keep the device in Self Refresh mode. When the SDRAM has entered Self Refresh mode all of the external control signals, except CKE, are disabled. The clock is internally disabled during Self Refresh Operation to save power. The user may halt the external clock while the device is in Self Refresh mode, however, the clock must be restarted before the device can exit Self Refresh operation. Once the clock is cycling, the device will exit Self Refresh operation after CKE is returned high. A minimum delay time is required when the device exits Self Refresh Operation and before the next command can be issued. This delay is equal to the /RAS cycle time (tRC) plus the Self Refresh exit time (tSREX). When using Self Refresh, both decks of a stacked device may be refreshed at the same time.

Power Down Mode

In order to reduce standby power consumption, two power down modes are available: Precharge and Active Power Down mode. To enter Precharge Power Down mode, all banks must be precharged and the necessary precharge delay (tRP) must occur before the SDRAM can enter the power down mode. If a bank is activated but not performing a Read or Write operation, Active Power Down mode will be entered. (Issuing a Power Down Mode Command when the device is performing a Read or Write operation causes the device to enter Clock Suspend mode. See the following section.) Once the Power Down mode is initiated by holding CKE low, all of the receiver circuits except CKE are gated off. The Power Down mode does not perform any refresh operations, therefore the device can't remain in Power Down mode longer than the Refresh period (tREF) of the device.

The Power Down mode is exited by bringing CKE high. When CKE goes high, a No Operation Command (or a Device Deselect Command) is required on the next rising clock edge.

Power Down Mode Exit Timing

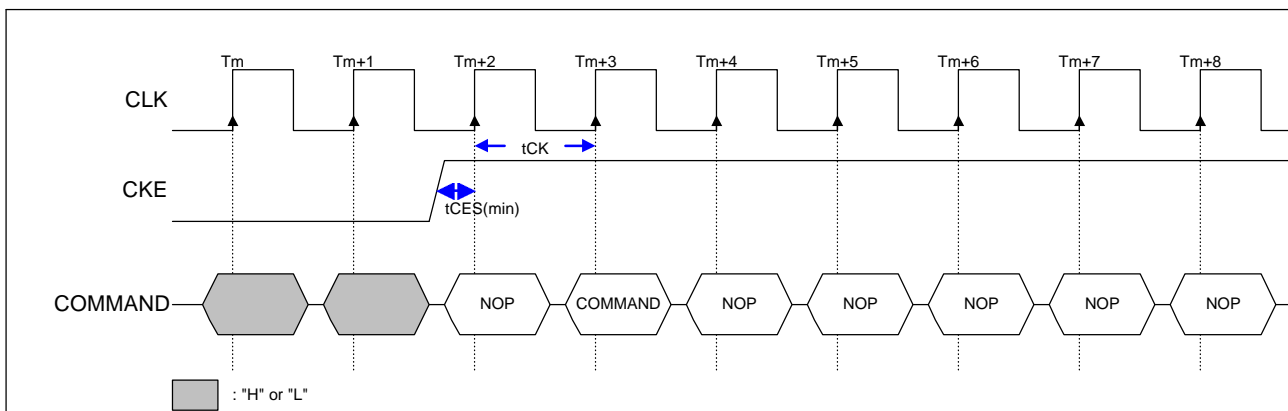

Data Mask

The SDRAM has a Data Mask function that can be used in conjunction with data read and write cycles. When the Data Mask is activated (DQM high) during a write cycle, the write operation is prohibited immediately (zero clock latency). If the Data Mask is activated during a read cycle, the data outputs are disabled and become high impedance after a two clock delay, independent of /CAS latency.

Data Mask Activated During a Read Cycle

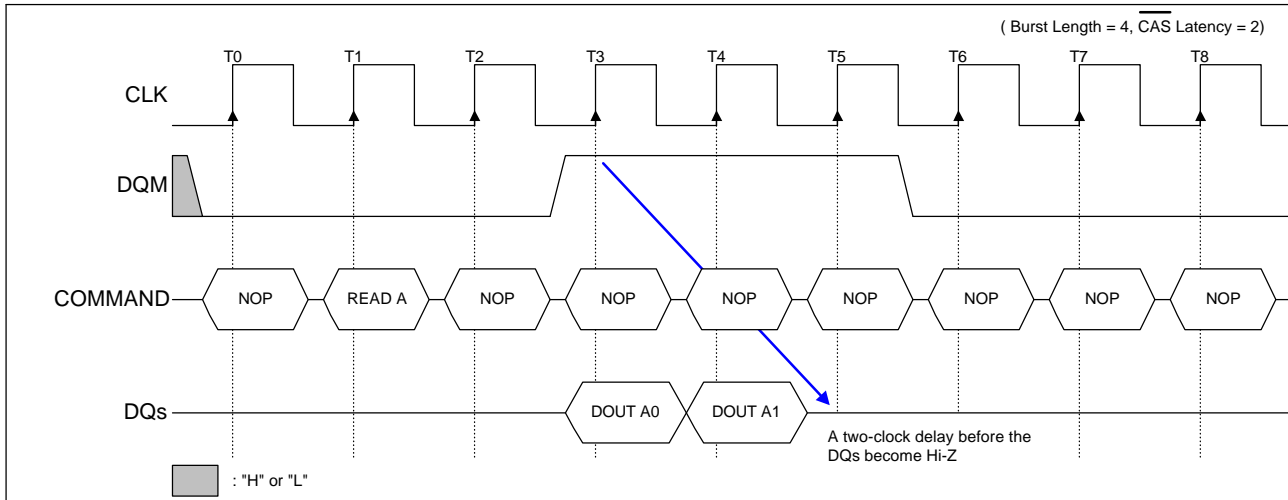

No Operation Command

The No Operation Command should be used in cases when the SDRAM is in a idle or a wait state. The purpose of the No Operation Command is to prevent the SDRAM from registering any unwanted commands between operations. A No Operation Command is registered when /CS is low with /RAS, /CAS, and /WE held high at the rising edge of the clock. A No Operation Command will not terminate a previous operation that is still executing, such as a burst read or write cycle.

Deselect Command

The Deselect Command performs the same function as a No Operation Command. Deselect Command occurs when /CS is brought high, the /RAS, /CAS, and /WE signals become don't cares.

Clock Suspend Mode

During normal access mode, CKE is held high enabling the clock. When CKE is registered low while at least one of the banks is active, Clock Suspend Mode is entered. The Clock Suspend mode deactivates the internal clock and suspends or "freezes" any clocked operation that was currently being executed. There is a one clock delay between the registration of CKE low and the time at which the SDRAM's operation suspends. While in Clock Suspend mode, the SDRAM ignores any new commands that are issued. The Clock Suspend mode is exited by bringing CKE high. There is a one clock cycle delay from when CKE returns high to when Clock Suspend mode is exited.

When the operation of the SDRAM is suspended during the execution of a Burst Read operation, the last valid data output onto the DQ pins will be actively held valid until Clock Suspend mode is exited.

Clock Suspend During a Read Cycle

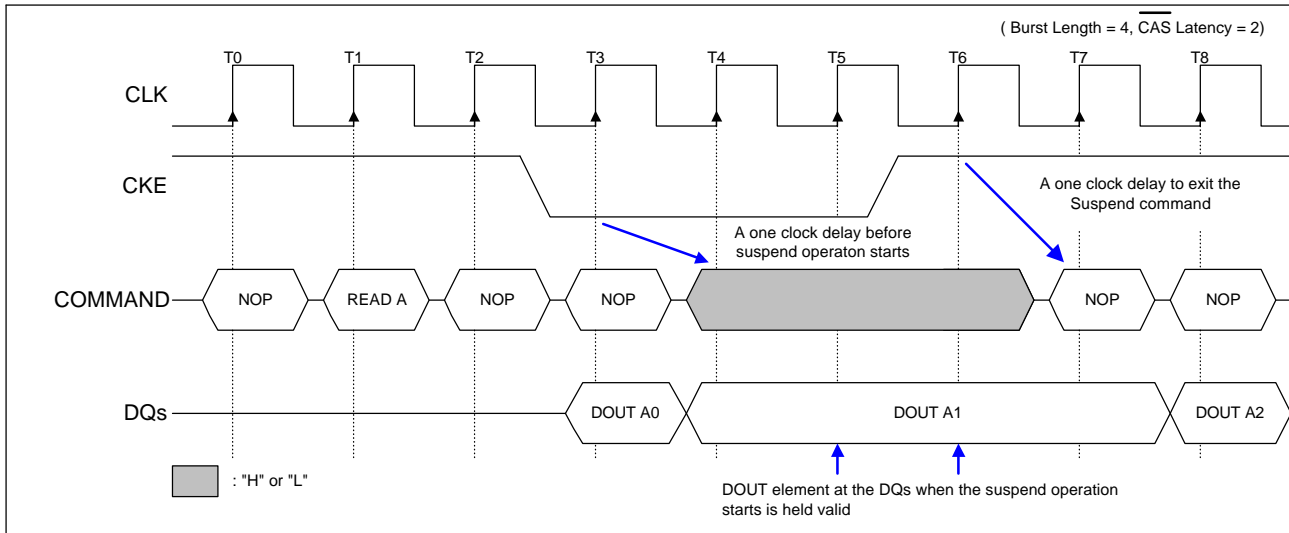

If Clock Suspend mode is initiated during a burst write operation, then the input data is masked and ignored until the Clock Suspend mode is exited.

Clock Suspend During a Write Cycle

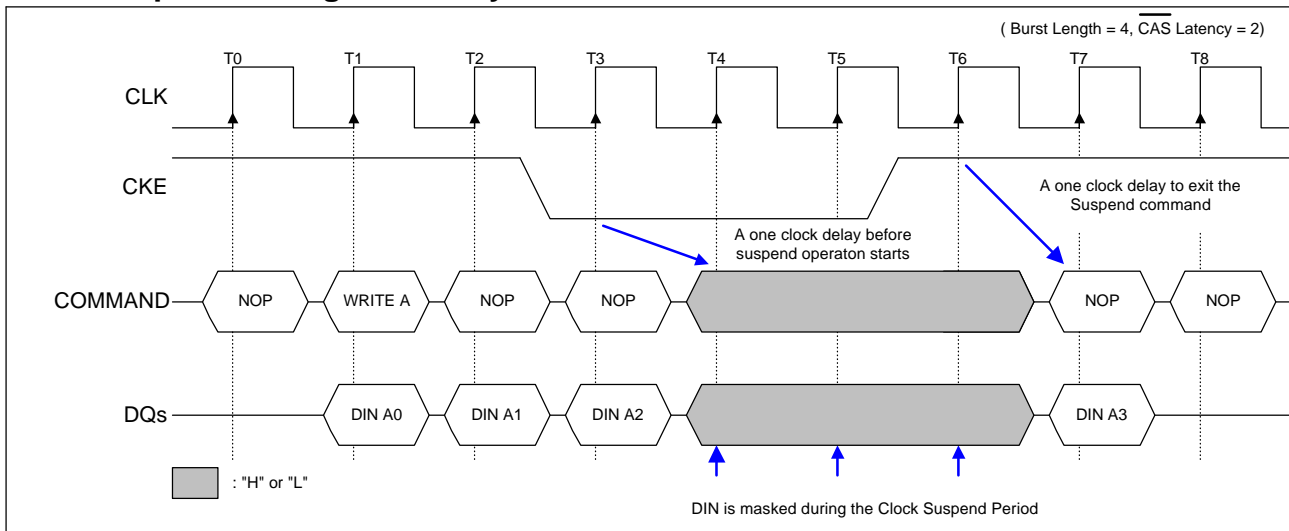

AC Parameters for Read Timing (3/3/3)

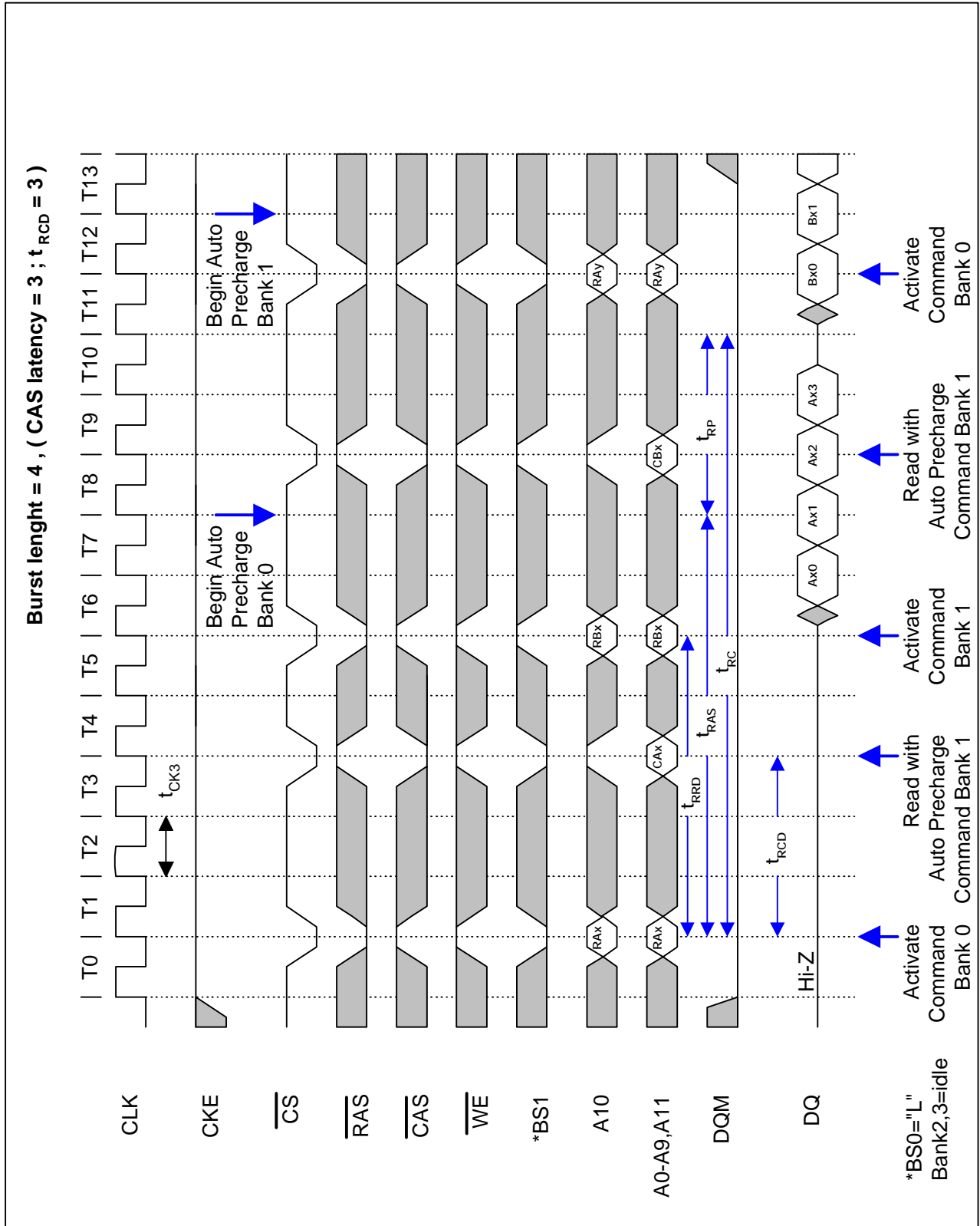

AC Parameters for Read Timing (2/2/2)

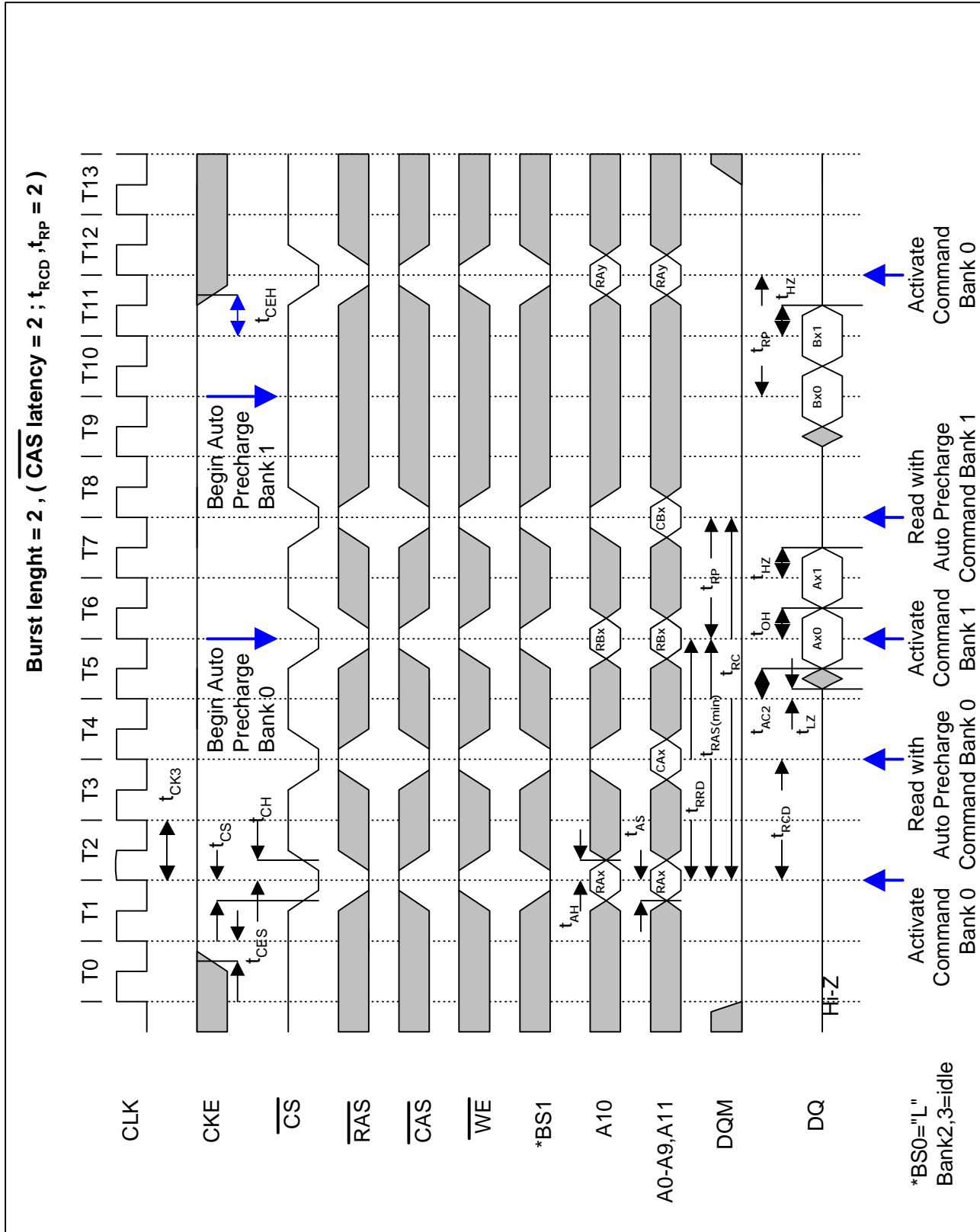

AC Parameters for Read Timing (3/2/2)

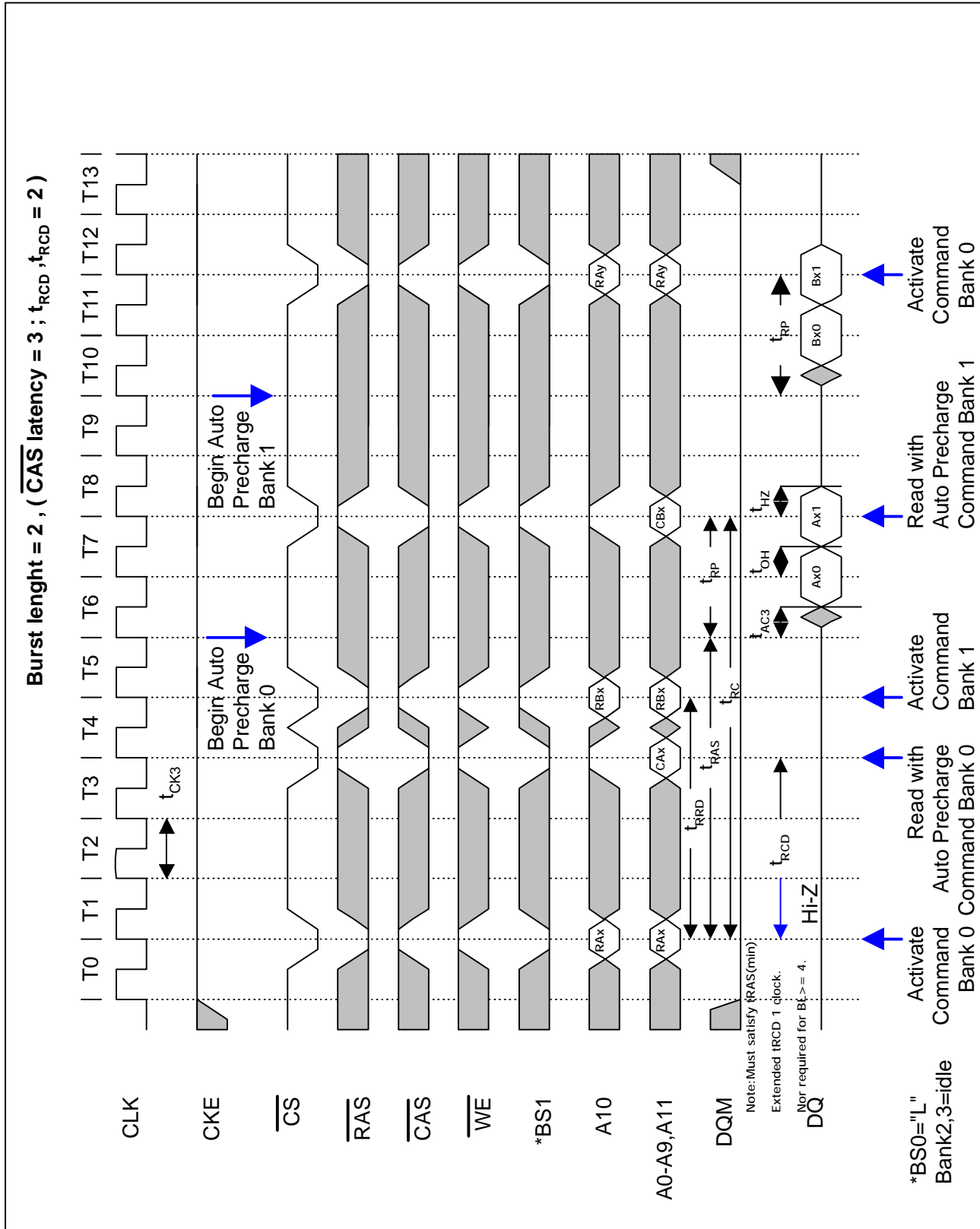



AC Parameters for Read Timing (3/3/3)

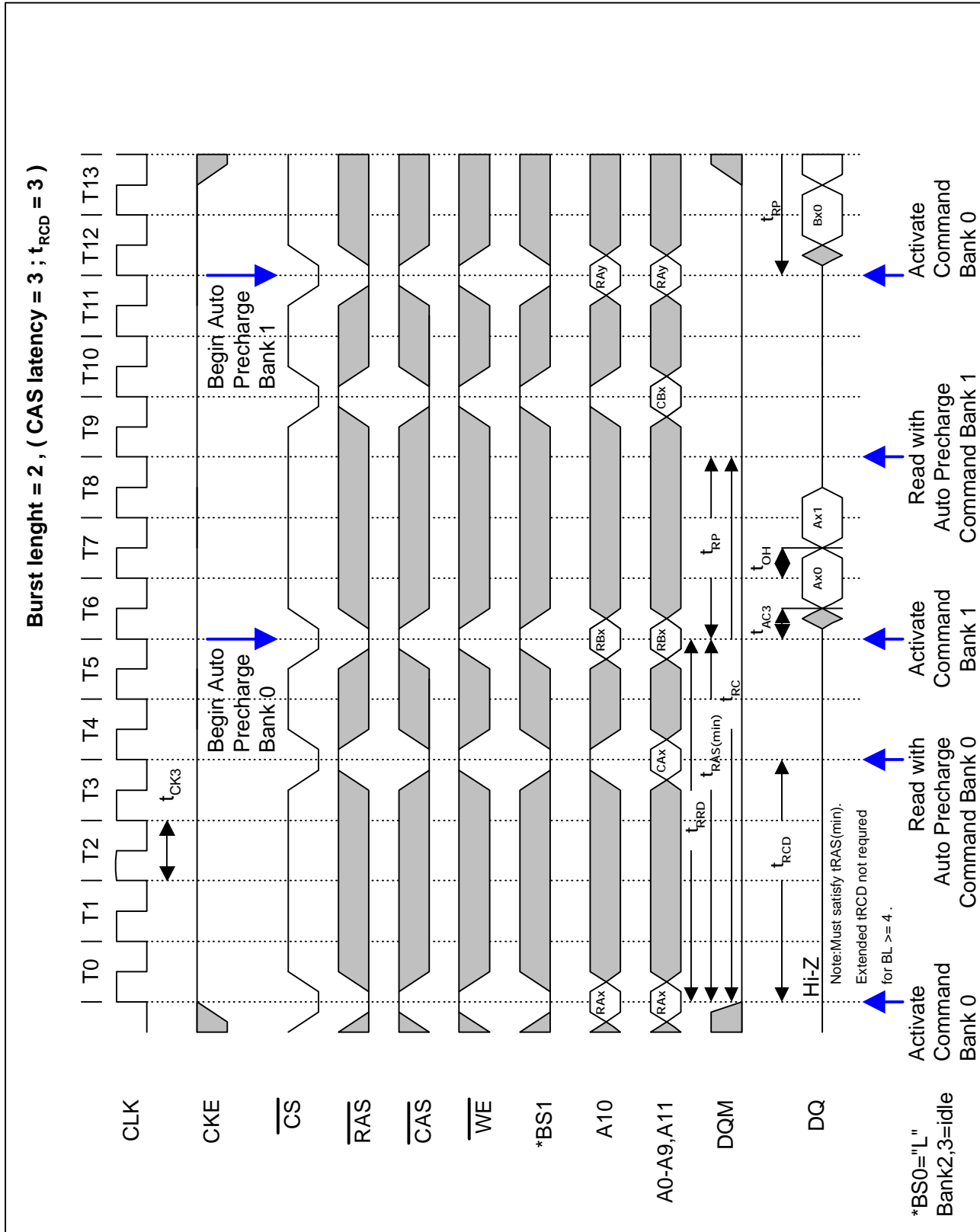

Mode Register Set

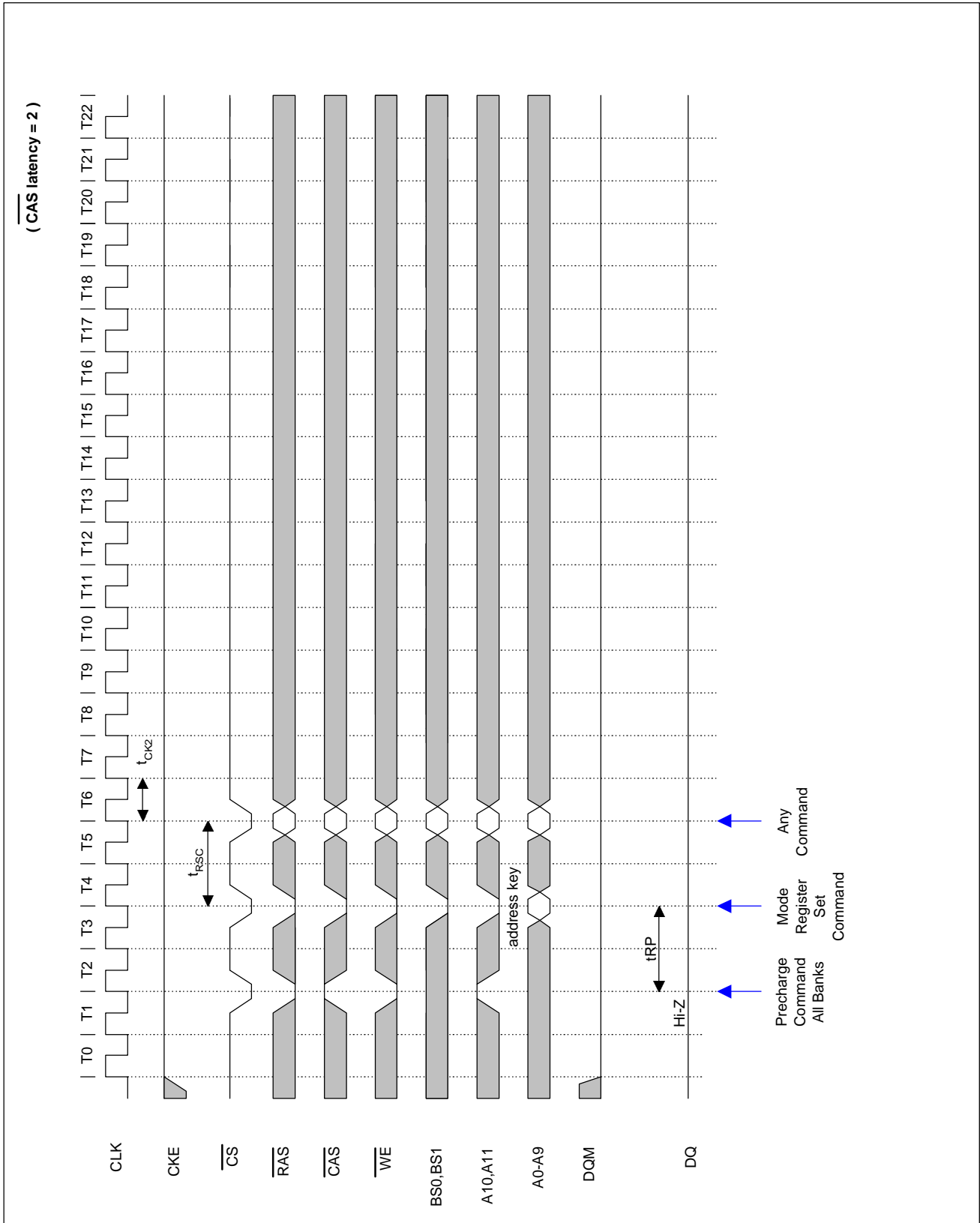



Power On Sequence and Auto Refresh (CBR)

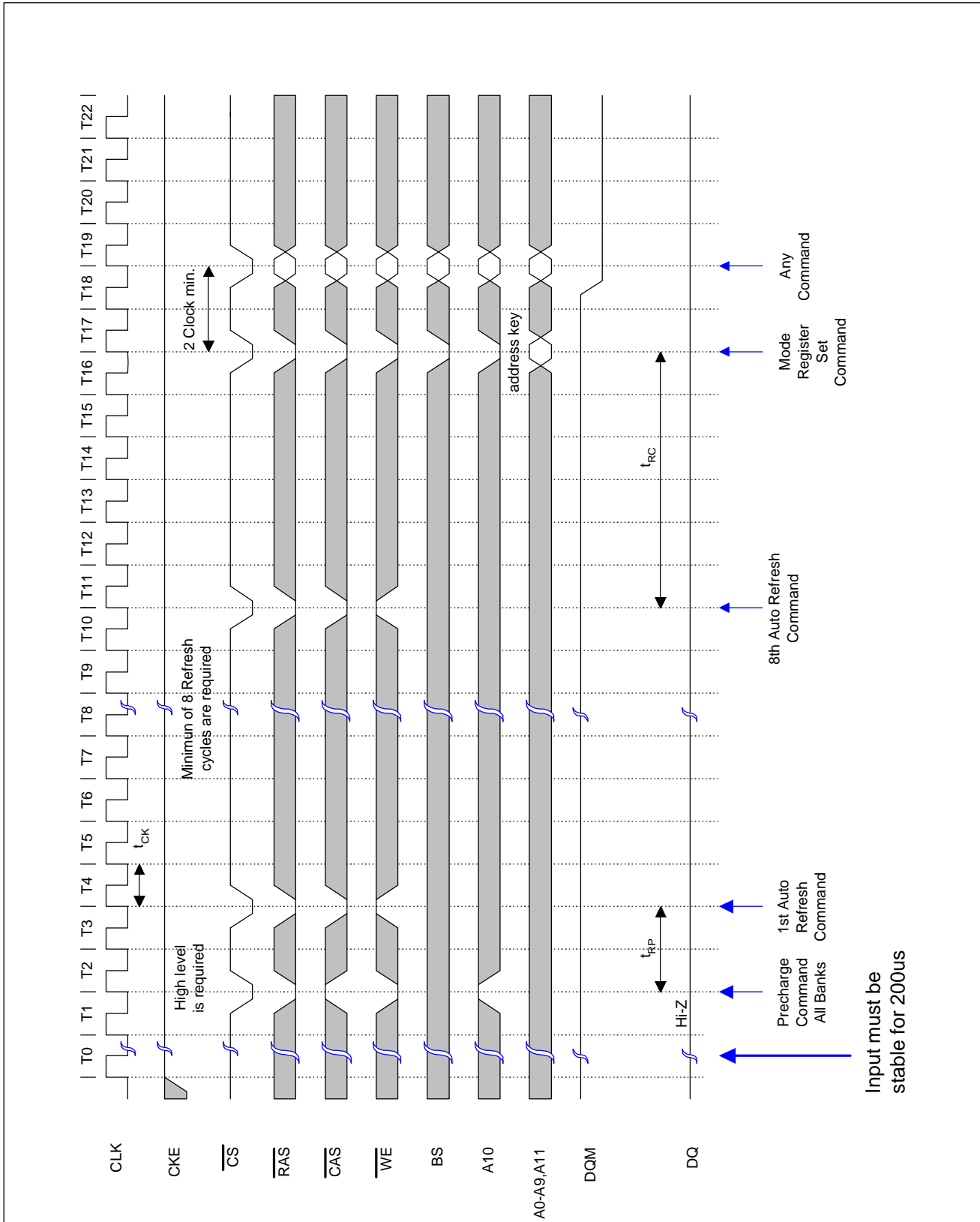

Clock Suspension, DQM during Burst Read

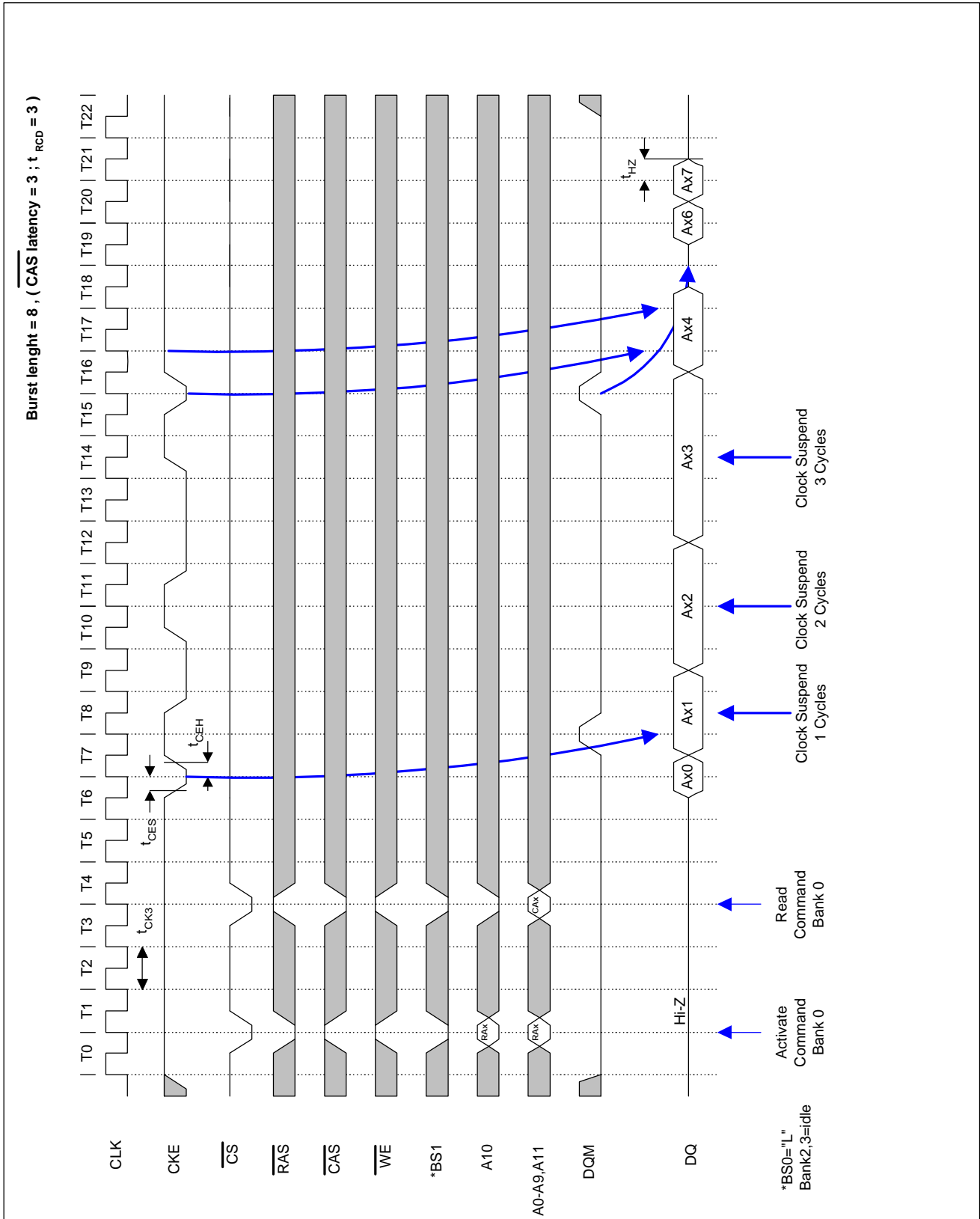



Clock Suspension, DQM during Burst Write

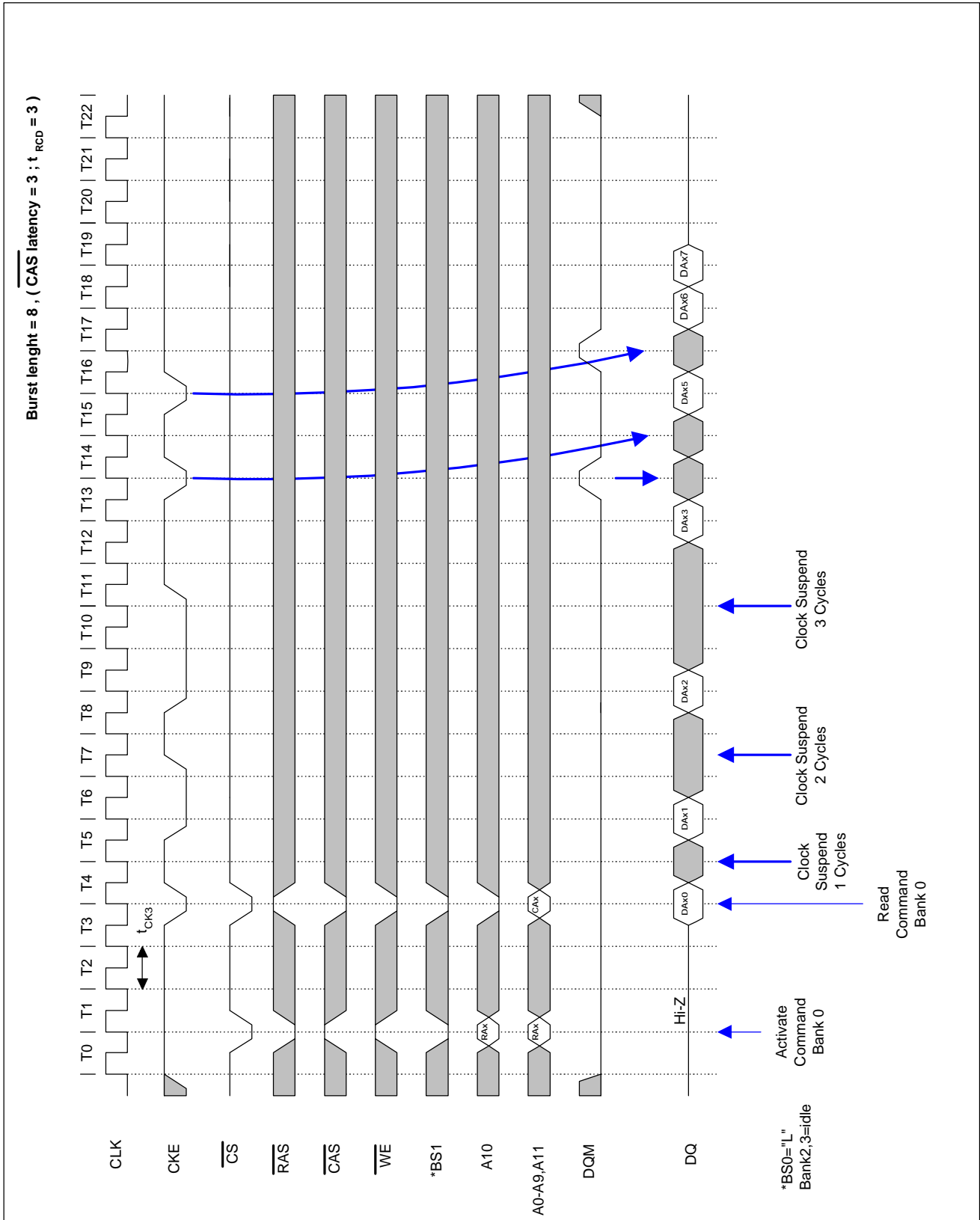

Power Down Mode and Clock Suspend

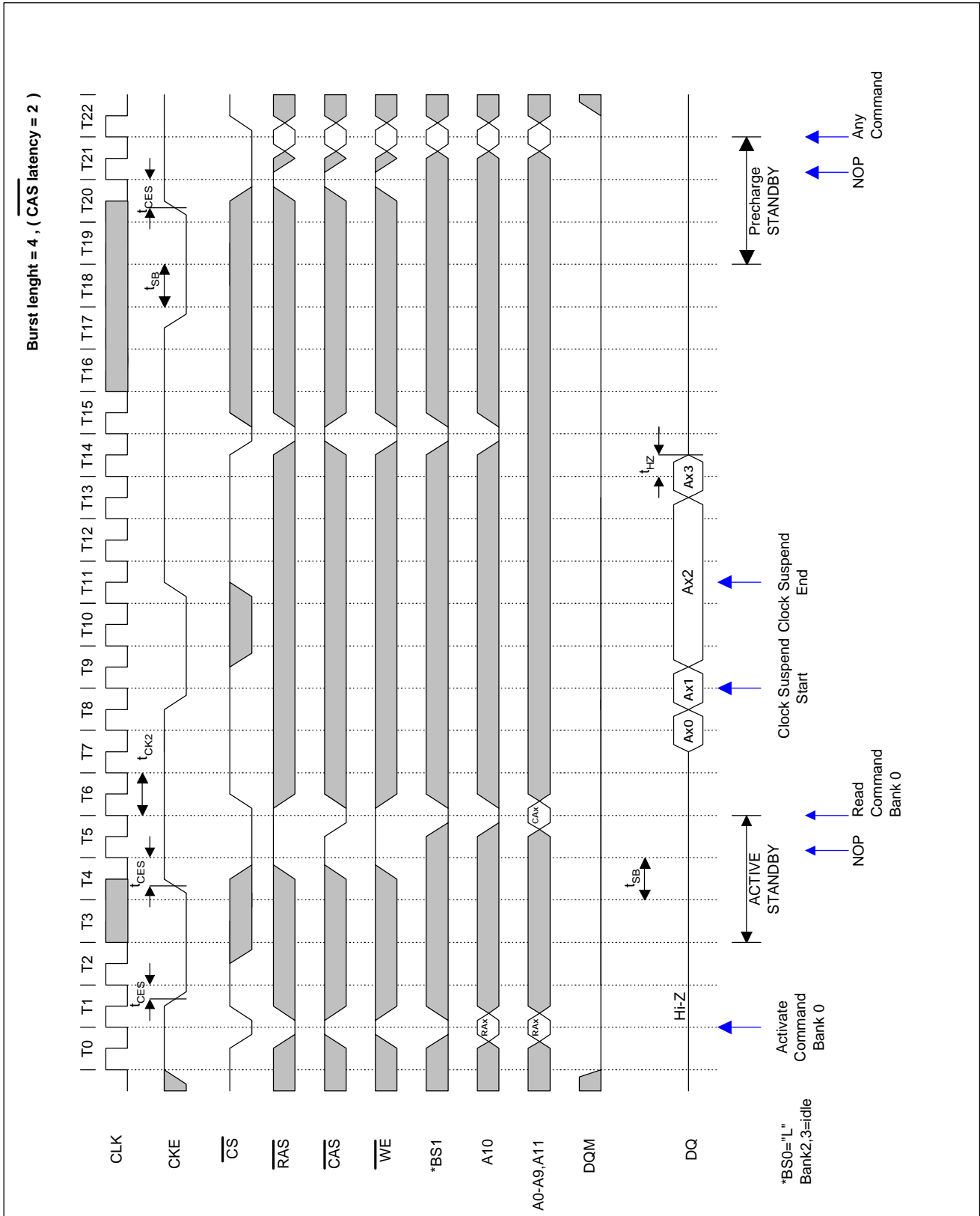



Auto Refresh (CBR)

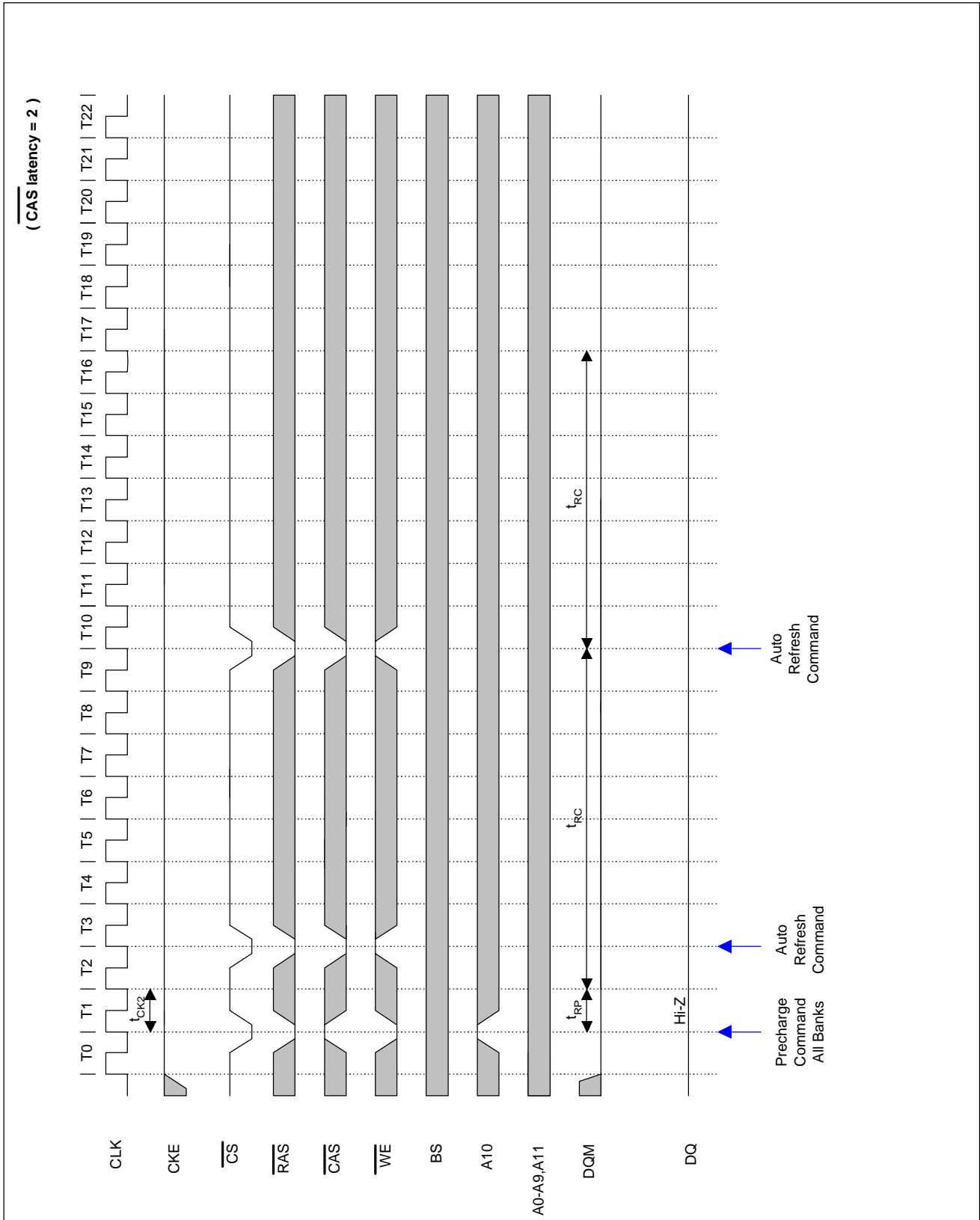



Self Refresh (Entry and Exit)

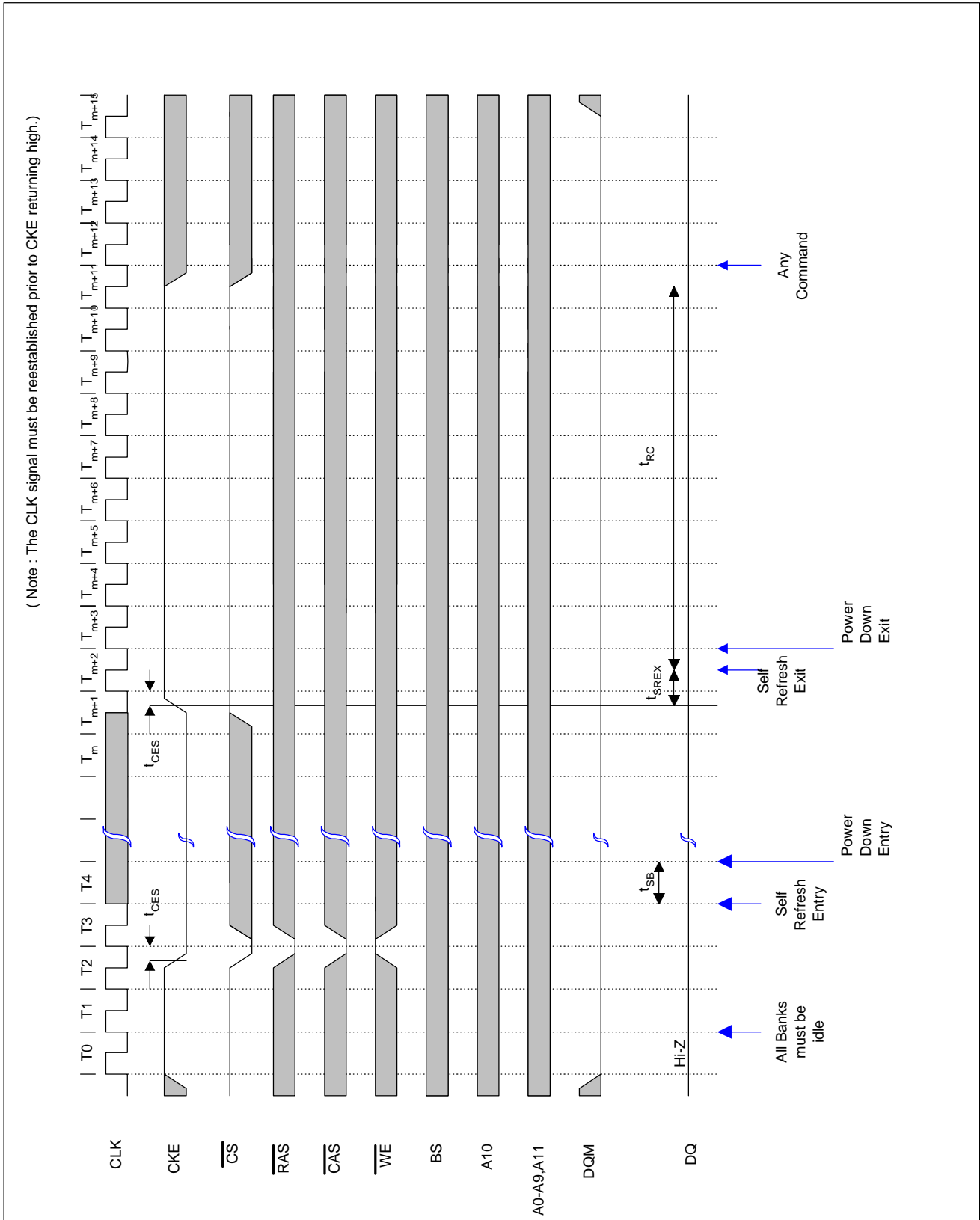

Random Row Read (Interleaving Banks) with Precharge

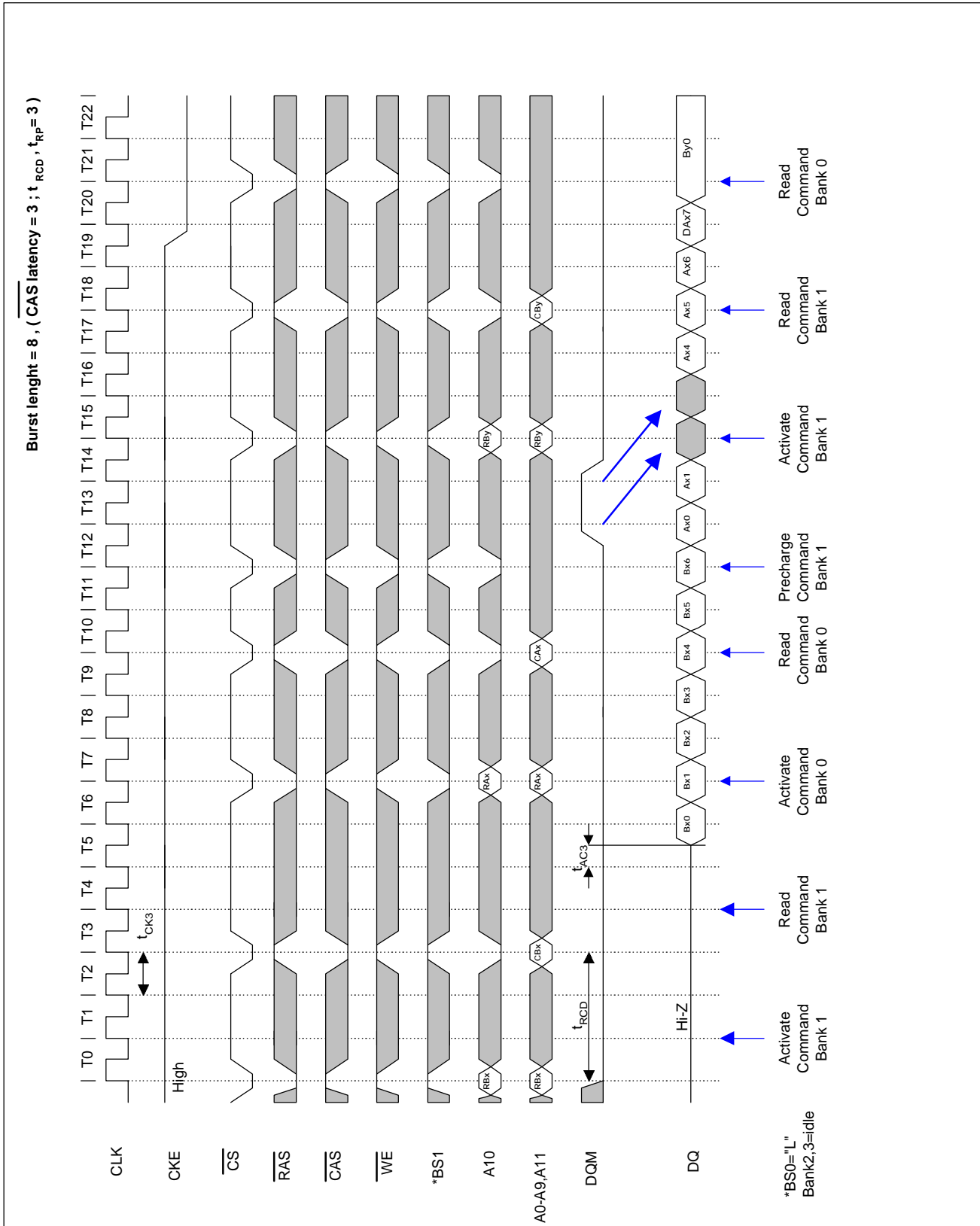



Random Row Read (Interleaving Banks) with Auto Precharge

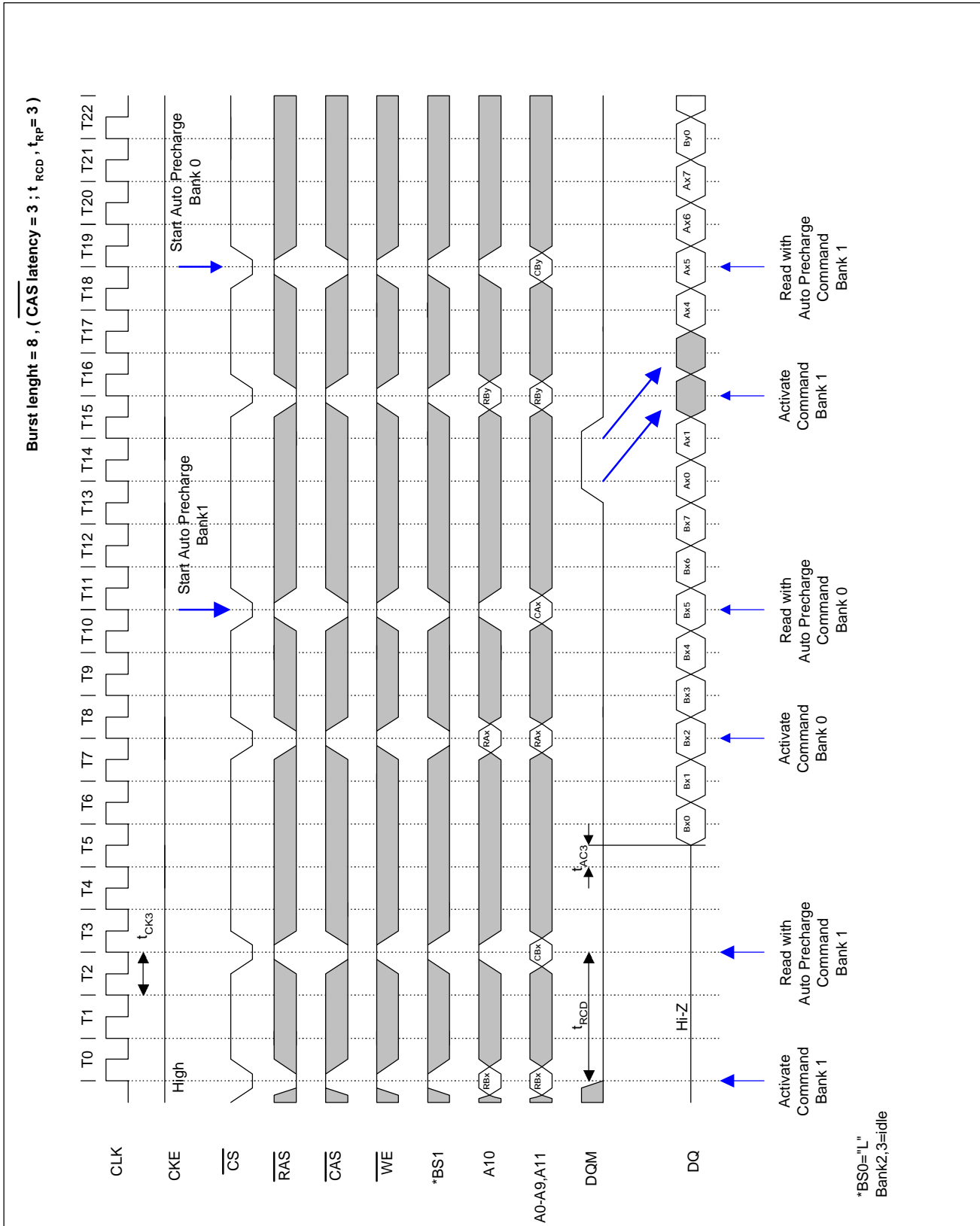



Random Row Write (Interleaving Banks) with Auto Precharge

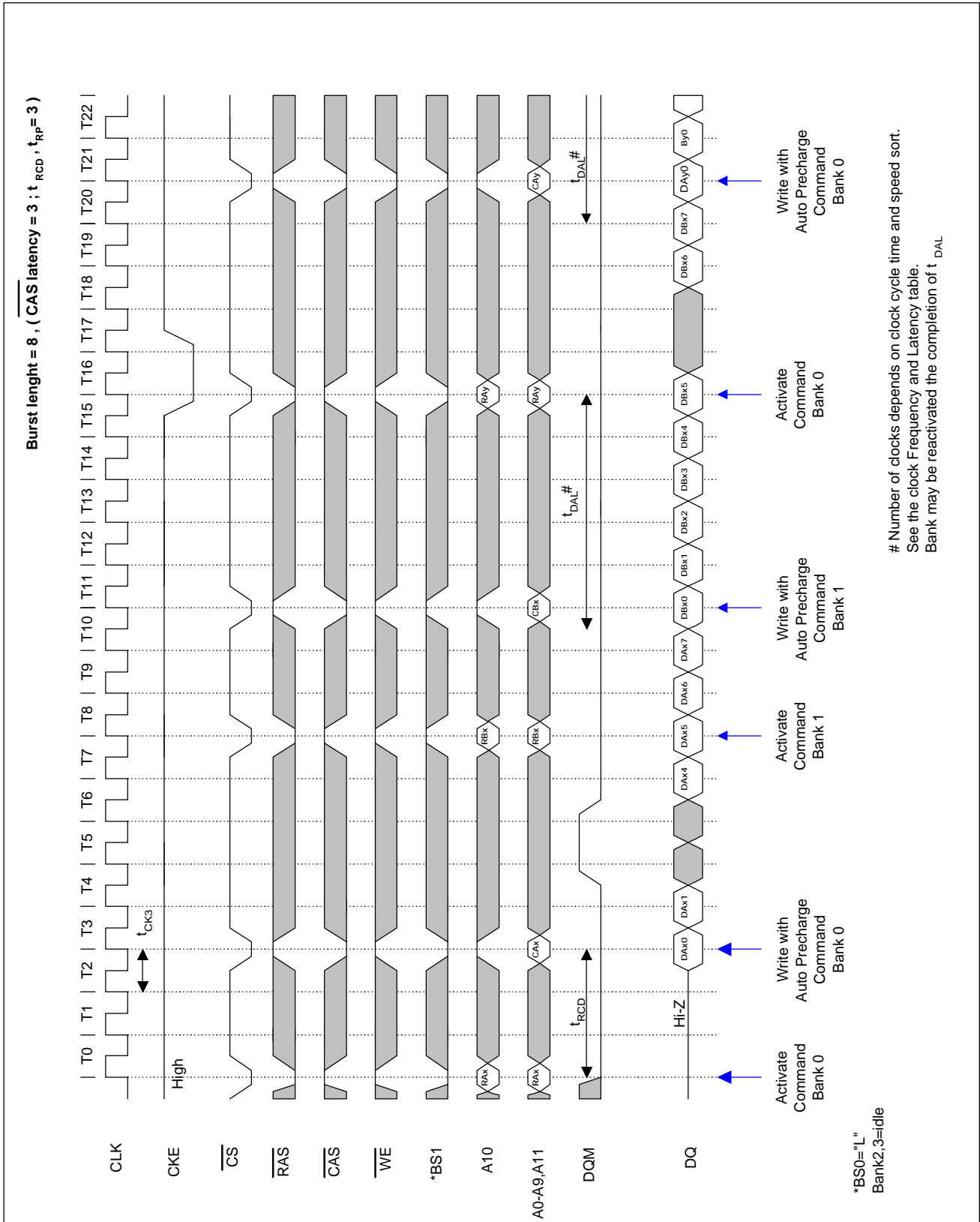



Random Row Write (Interleaving Banks) with Precharge

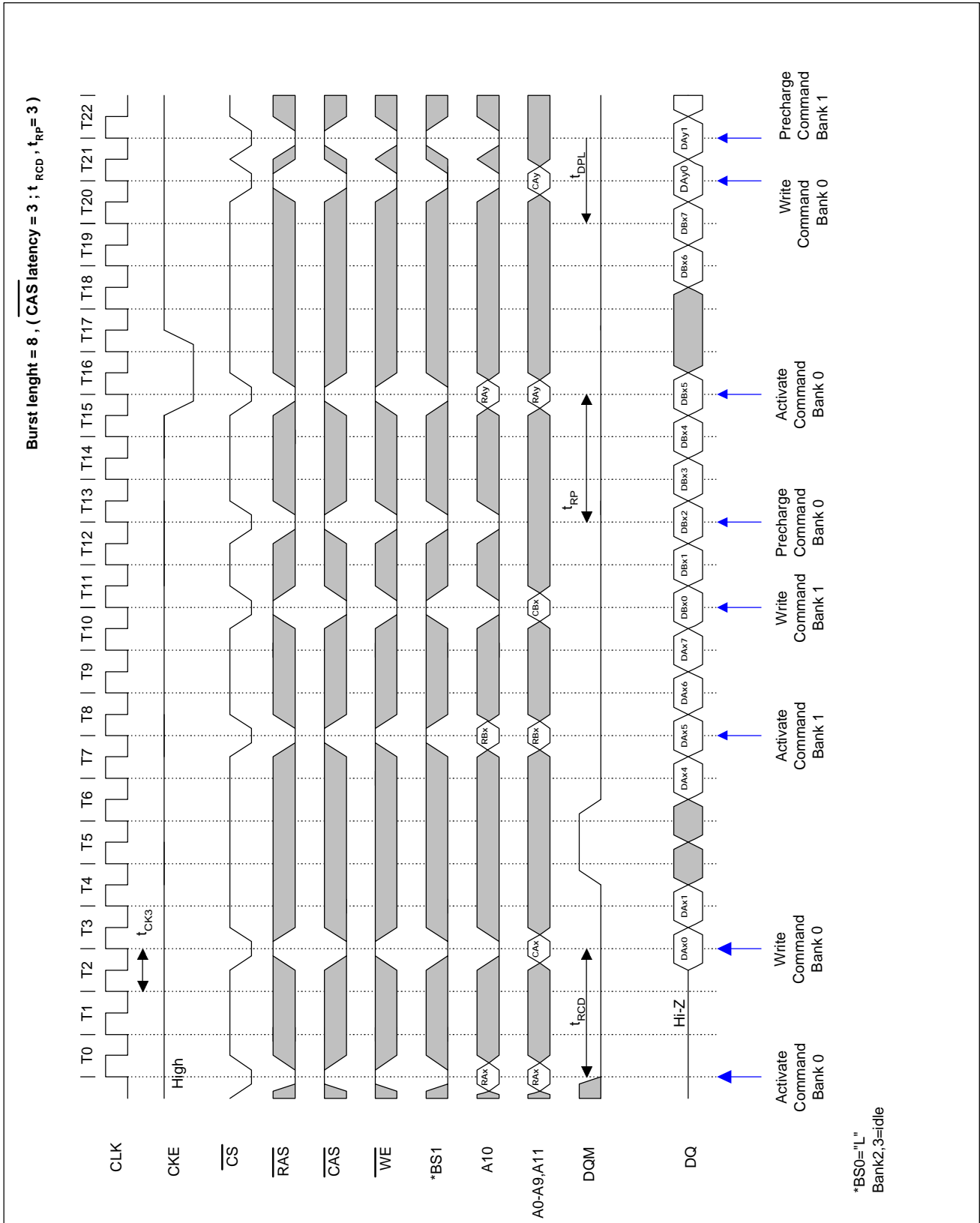



Read-Write Cycle

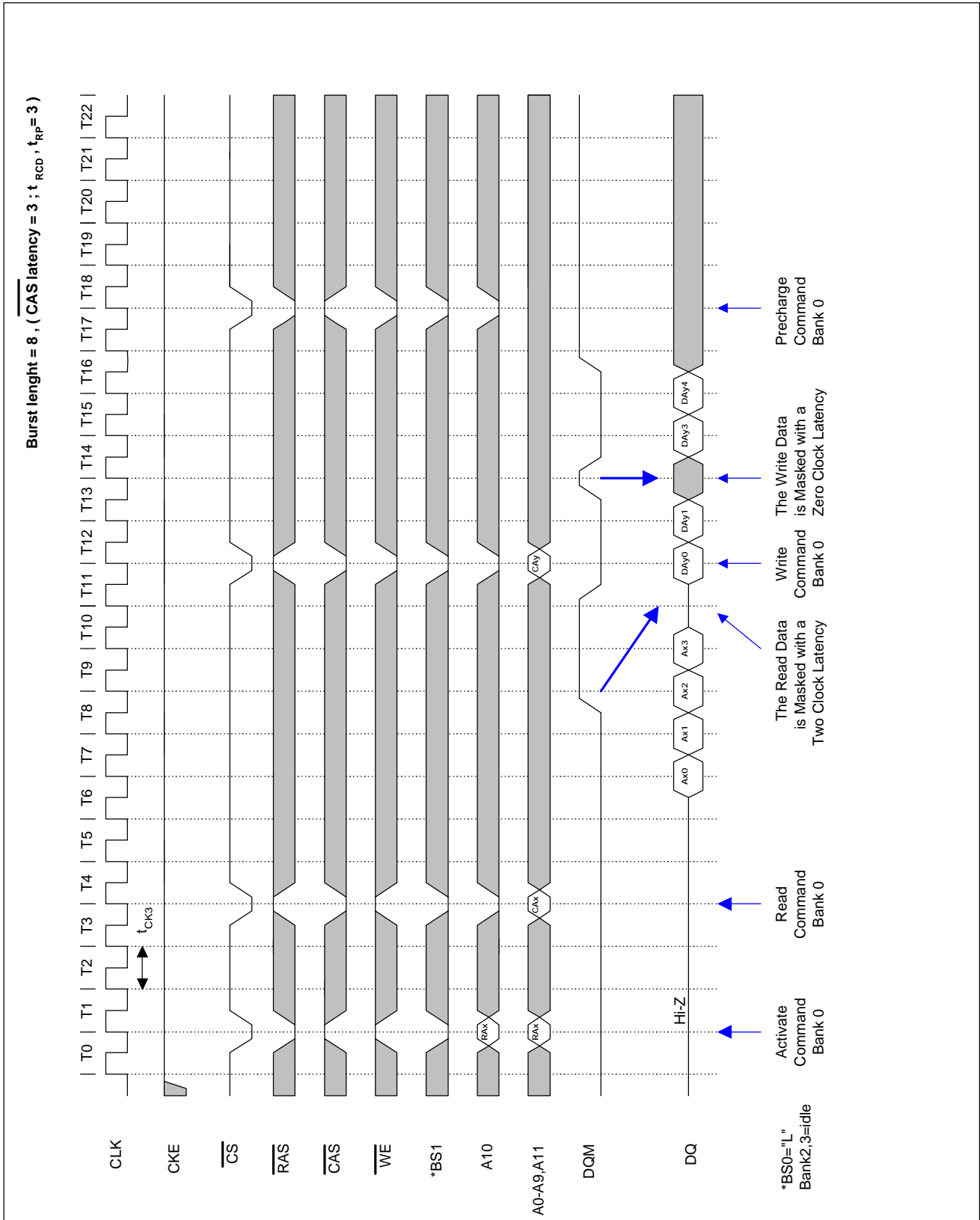



Interleaved Column Read Cycle

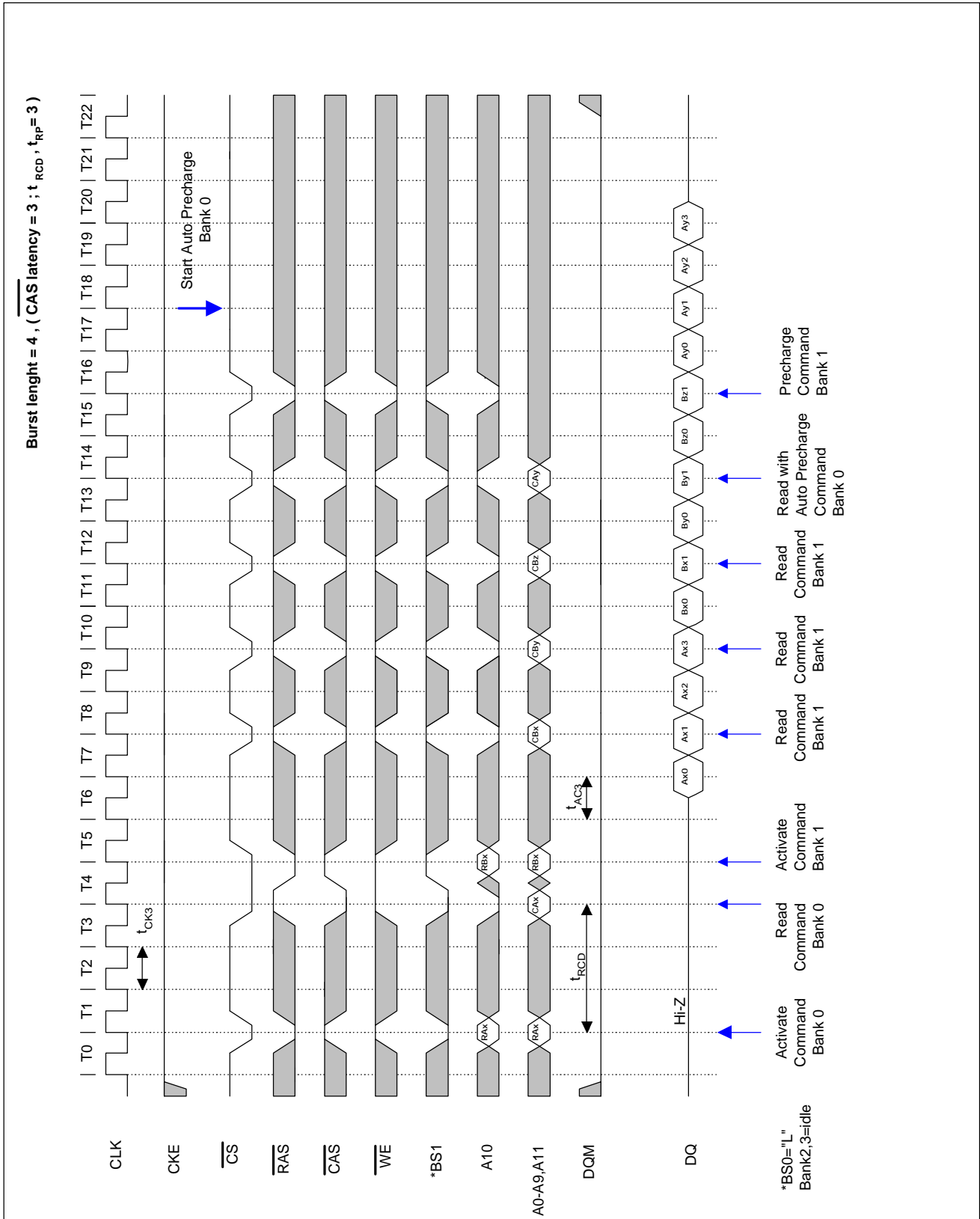

Auto Precharge after Read Burst

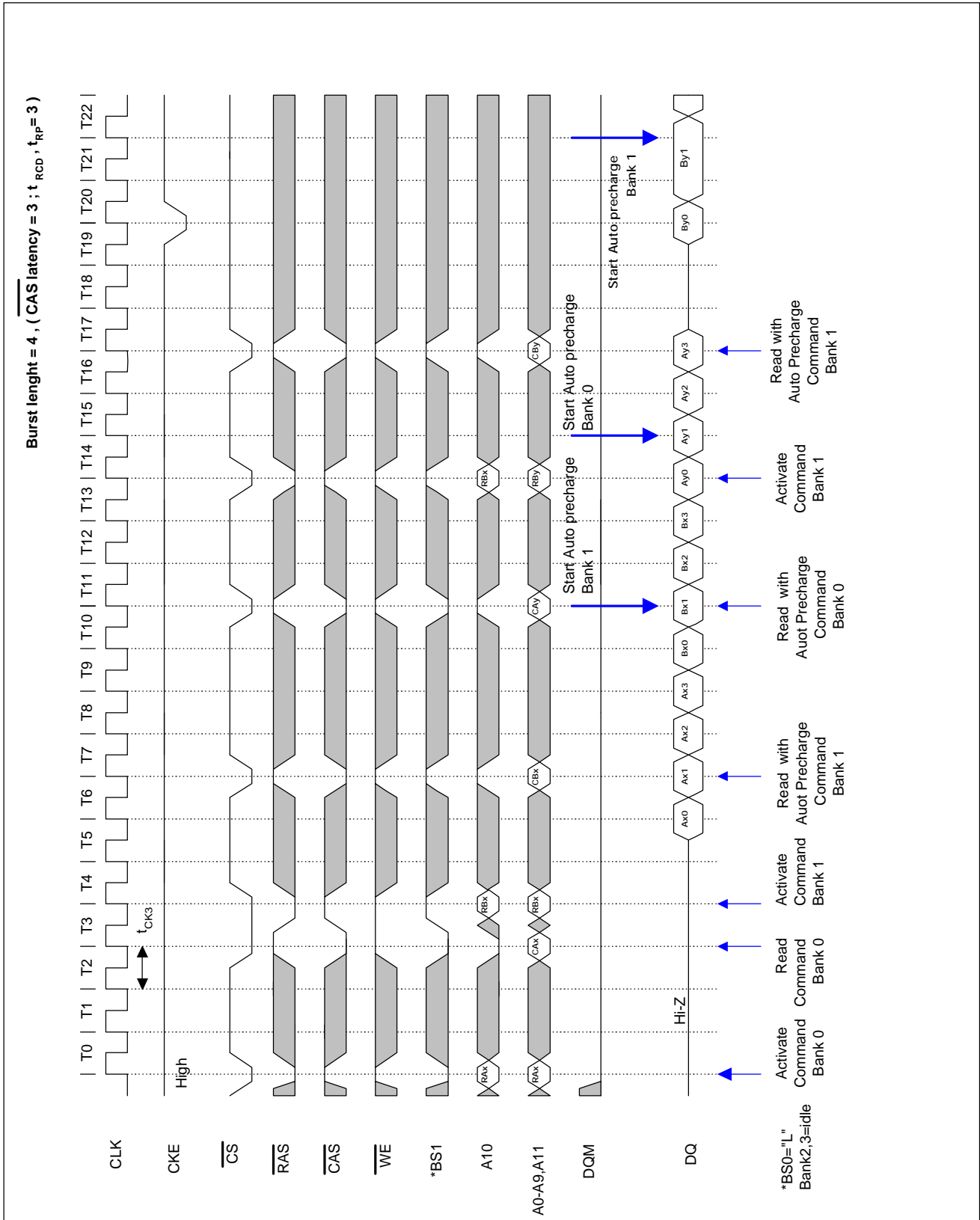

Burst Read and Single Write Operation

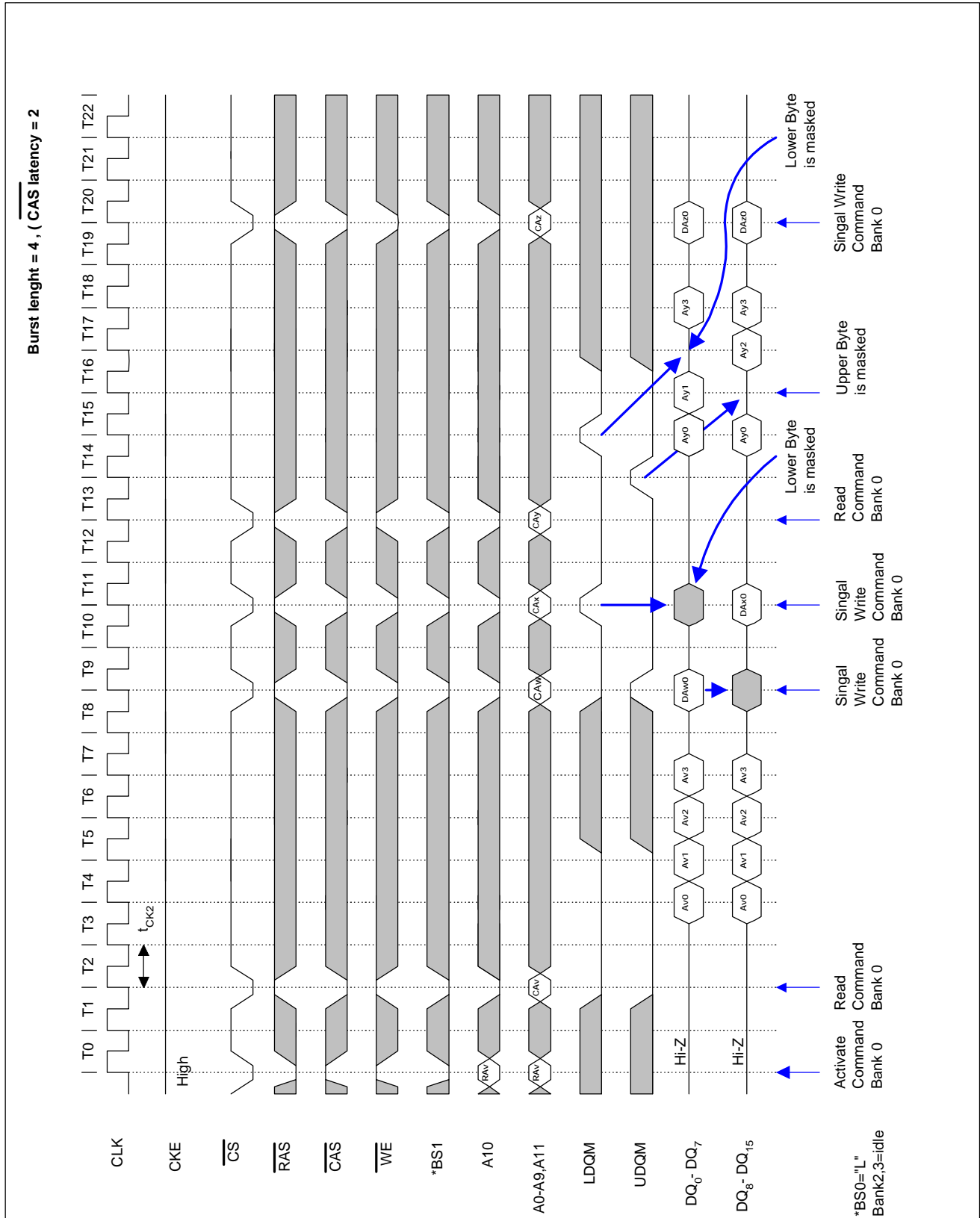



/CS Function (Only /CS signal needs to be asserted at minimum rate)

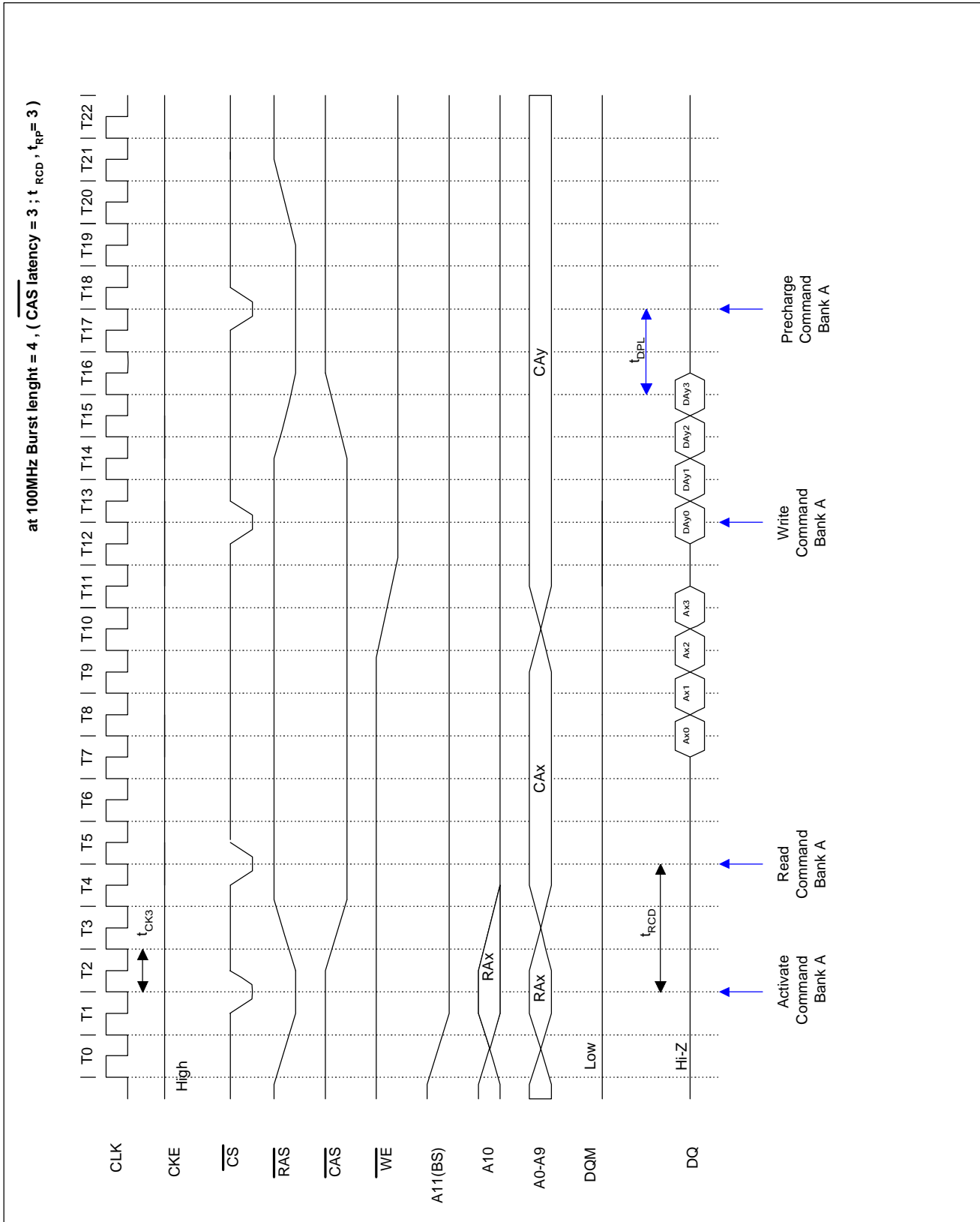

Package Dimension

(400 mil; 54 pin; Thin Small Outline Package)

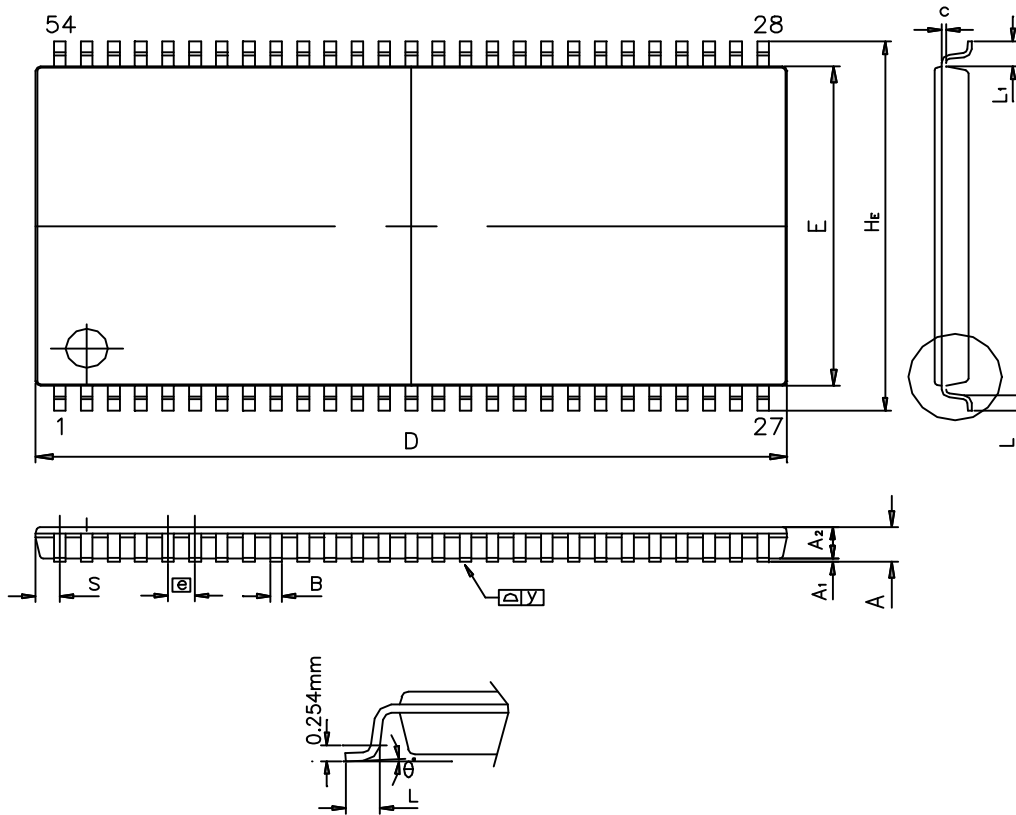

SYMBOL	MILLIMETER			INCH		
	MIN.	NOM.	MAX.	MIN.	NOM.	MAX.
A			1.20			0.047
A1	0.05	0.10	0.15	0.002	0.004	0.006
A2	0.95	1.00	1.05	0.037	0.039	0.041
B	0.30	0.35	0.45	0.012	0.014	0.018
c	0.12		0.21	0.005		0.008
D	22.22 BSC			0.875 BSC		
HE	11.56	11.76	11.96	0.460	0.463	0.470
E	10.03	10.16	10.29	0.390	0.400	0.410
e	0.80 BSC			0.031		
L	0.40	0.50	0.60	0.016	0.020	0.024
L1	0.80 REF			0.031 REF		
S	0.71 REF			0.028 REF		
θ	0°	-	8°	0°	-	8°

Note:

1. Dimension D does not include mold protrusions or gate burrs.
2. Mold protrusion and gate burrs shall exceed 0.15 mm per side.
3. Dimension E1 does not include interlead mold protrusions.
4. Interlead mold protrusions shall not exceed 0.25 mm per side.