

CDC305 OCTAL DIVIDE-BY-2 CIRCUIT/CLOCK DRIVER

SCAS326A – JUNE 1990 – REVISED NOVEMBER 1995

- Replaces SN74AS305
- Maximum Output Skew of 1 ns
- Maximum Pulse Skew of 1 ns
- TTL-Compatible Inputs and Outputs
- Center-Pin V_{CC} and GND Configurations Minimize High-Speed Switching Noise
- Package Options Include Plastic Small-Outline (D) Package and Standard Plastic (N) 300-mil DIPs

D OR N PACKAGE
(TOP VIEW)

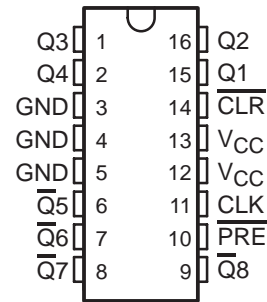

description

The CDC305 contains eight flip-flops designed to have low skew between outputs. The eight outputs (four in-phase with CLK and four out-of-phase) toggle on successive CLK pulses. Preset (\overline{PRE}) and clear (\overline{CLR}) inputs are provided to set the Q and \overline{Q} outputs high or low independent of the clock (CLK) input.

The CDC305 has output and pulse-skew parameters $t_{sk(o)}$ and $t_{sk(p)}$ to ensure performance as a clock driver when a divide-by-two function is required.

The CDC305 is characterized for operation from 0°C to 70°C.

FUNCTION TABLE

INPUTS			OUTPUTS	
\overline{CLR}	\overline{PRE}	CLK	Q1–Q4	$\overline{Q5}–\overline{Q8}$
L	H	X	L	H
H	L	X	H	L
L	L	X	L [†]	L [†]
H	H	L	Q ₀	\overline{Q}_0
H	H	↑	\overline{Q}_0	Q ₀

[†] This configuration does not persist when \overline{PRE} or \overline{CLR} returns to its inactive (high) level.



Please be aware that an important notice concerning availability, standard warranty, and use in critical applications of Texas Instruments semiconductor products and disclaimers thereto appears at the end of this data sheet.

PRODUCTION DATA information is current as of publication date. Products conform to specifications per the terms of Texas Instruments standard warranty. Production processing does not necessarily include testing of all parameters.

**TEXAS
INSTRUMENTS**

POST OFFICE BOX 655303 • DALLAS, TEXAS 75265
POST OFFICE BOX 1443 • HOUSTON, TEXAS 77251-1443

Copyright © 1995, Texas Instruments Incorporated

CDC305 OCTAL DIVIDE-BY-2 CIRCUIT/CLOCK DRIVER

SCAS326A – JUNE 1990 – REVISED NOVEMBER 1995

logic symbol†

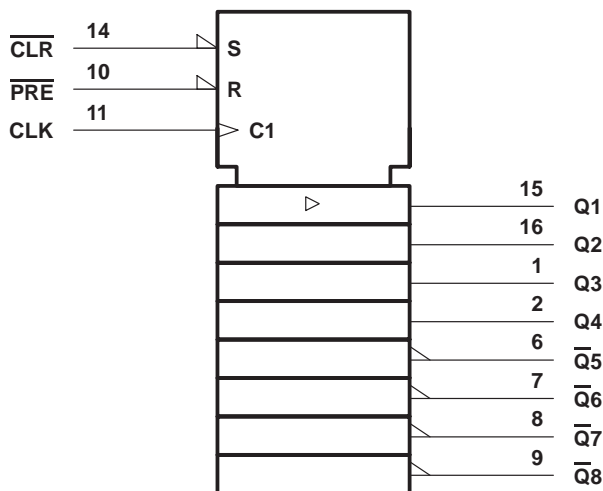

† This symbol is in accordance with ANSI/IEEE Std 91-1984 and IEC Publication 617-12.

logic diagram (positive logic)

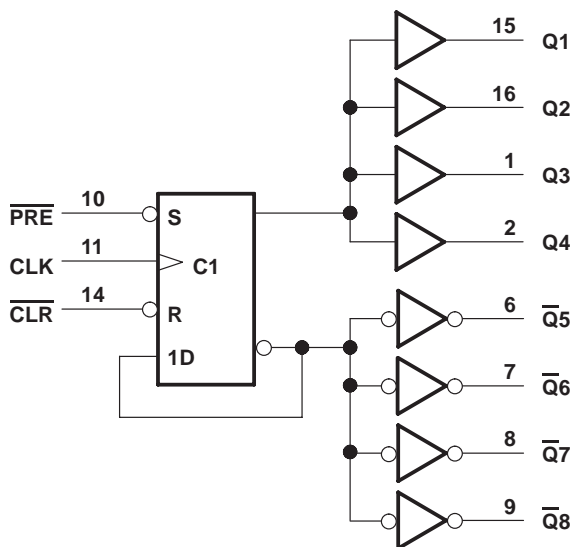

absolute maximum ratings over operating free-air temperature range (unless otherwise noted)‡

Supply voltage, V_{CC}	7 V
Input voltage, V_I	7 V
Maximum power dissipation at $T_A = 55^\circ\text{C}$ (in still air) (see Note 1): D package	0.77 W
N package	1.2 W
Storage temperature range, T_{stg}	-65°C to 150°C

‡ Stresses beyond those listed under "absolute maximum ratings" may cause permanent damage to the device. These are stress ratings only and functional operation of the device at these or any other conditions beyond those indicated under "recommended operating conditions" is not implied. Exposure to absolute-maximum-rated conditions for extended periods may affect device reliability.

NOTE 1: The maximum package power dissipation is calculated using a junction temperature of 150°C and a board trace length of 300 mils, except for the N package, which has a trace length of zero. For more information, refer to the *Package Thermal Considerations* application note in the 1994 *ABT Advanced BiCMOS Technology Data Book*, literature number SCBD002B.



CDC305 OCTAL DIVIDE-BY-2 CIRCUIT/CLOCK DRIVER

SCAS326A – JUNE 1990 – REVISED NOVEMBER 1995

recommended operating conditions

		MIN	NOM	MAX	UNIT
V_{CC}	Supply voltage	4.5	5	5.5	V
V_{IH}	High-level input voltage	2			V
V_{IL}	Low-level input voltage			0.8	V
I_{OH}	High-level output current			-24	mA
I_{OL}	Low-level output current			48	mA
T_A	Operating free-air temperature	0		70	°C

electrical characteristics over recommended operating free-air temperature range (unless otherwise noted)

PARAMETER	TEST CONDITIONS		MIN	TYP†	MAX	UNIT
V_{IK}	$V_{CC} = 4.5\text{ V}$,	$I_I = -18\text{ mA}$			-1.2	V
V_{OH}	$V_{CC} = 4.5\text{ V to } 5.5\text{ V}$,	$I_{OH} = -2\text{ mA}$	$V_{CC} - 2$			V
	$V_{CC} = 4.5\text{ V}$,	$I_{OH} = -24\text{ mA}$	2	2.8		
V_{OL}	$V_{CC} = 4.5\text{ V}$,	$I_{OL} = 48\text{ mA}$		0.3	0.5	V
I_I	$V_{CC} = 5.5\text{ V}$,	$V_I = 7\text{ V}$			0.1	mA
I_{IH}	$V_{CC} = 5.5\text{ V}$,	$V_I = 2.7\text{ V}$			20	μA
I_{IL}	$V_{CC} = 5.5\text{ V}$,	$V_I = 0.4\text{ V}$			-0.5	mA
$I_{O\ddagger}$	$V_{CC} = 5.5\text{ V}$,	$V_O = 2.25\text{ V}$	-50		-150	mA
I_{CC}	$V_{CC} = 5.5\text{ V}$,	See Note 2		40	70	mA

† All typical values are at $V_{CC} = 5\text{ V}$, $T_A = 25^\circ\text{C}$.

‡ The output conditions have been chosen to produce a current that closely approximates one half of the true short-circuit output current, I_{OS} .

NOTE 2: I_{CC} is measured with CLK and $\overline{\text{PRE}}$ grounded, then with CLK and CLR grounded.

timing requirements over recommended ranges of supply voltage and operating free-air temperature

		MIN	MAX	UNIT
f_{clock}	Clock frequency	0	80	MHz
t_w	Pulse duration	$\overline{\text{CLR}}$ or $\overline{\text{PRE}}$ low	5	ns
		CLK high	4	
		CLK low	6	
t_{su}	Setup time before CLK↑		6	ns
				$\overline{\text{CLR}}$ or $\overline{\text{PRE}}$ inactive



CDC305 OCTAL DIVIDE-BY-2 CIRCUIT/CLOCK DRIVER

SCAS326A – JUNE 1990 – REVISED NOVEMBER 1995

switching characteristics over recommended ranges of supply voltage and operating free-air temperature (unless otherwise noted) (see Figure 1)

PARAMETER	FROM (INPUT)	TO (OUTPUT)	TEST CONDITIONS	MIN	TYP†	MAX	UNIT
$f_{max}‡$				80			MHz
t_{PLH}	CLK	Q, \bar{Q}	$R_L = 500 \Omega, C_L = 50 \text{ pF}$	2	6	9	ns
t_{PHL}				2	6	9	
t_{PLH}	$\overline{\text{PRE}}$ or $\overline{\text{CLR}}$	Q, \bar{Q}	$R_L = 500 \Omega, C_L = 50 \text{ pF}$	3	7	12	ns
t_{PHL}				3	7	12	
$t_{sk(o)}$	CLK	\bar{Q}	$R_L = 500 \Omega, C_L = 10 \text{ pF to } 30 \text{ pF, See Figure 2}$			1	ns
		Q				1	
		Q1–Q8				1.5	
$t_{sk(p)}$	CLK	Q1, $\bar{Q}8$	$R_L = 500 \Omega, C_L = 10 \text{ pF to } 30 \text{ pF}$			1.5	ns
		Q2– $\bar{Q}7$				2	
t_r						4.5	ns
t_f						3.5	ns

† All typical values are at $V_{CC} = 5 \text{ V}, T_A = 25^\circ\text{C}$.

‡ f_{max} minimum values are at $C_L = 0 \text{ to } 30 \text{ pF}$.

PARAMETER MEASUREMENT INFORMATION

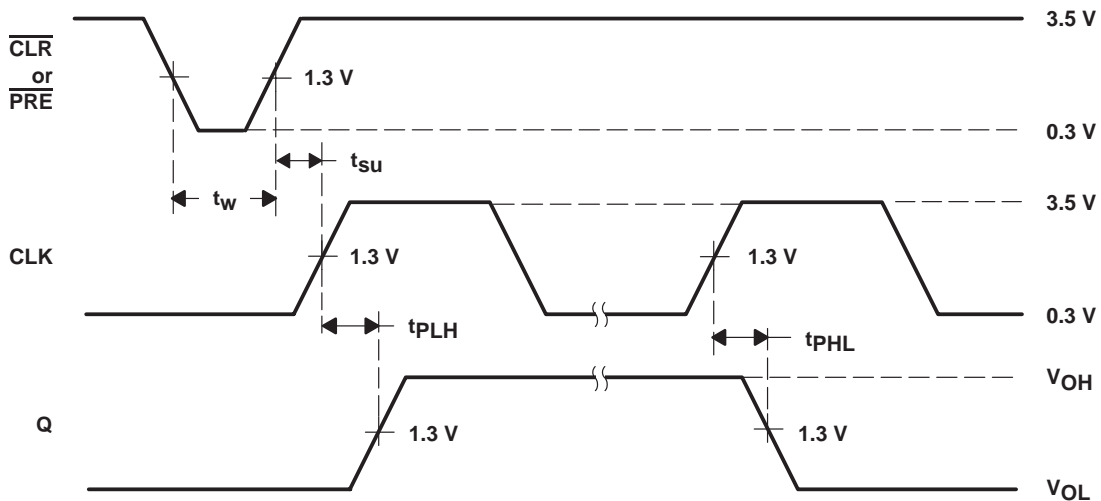
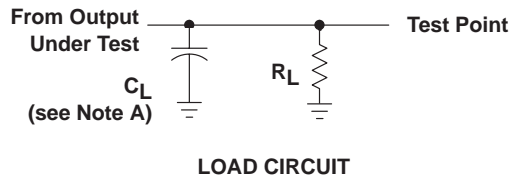

NOTES: A. C_L includes probe and jig capacitance.

B. Input pulses are supplied by generators having the following characteristics: $PRR \leq 10 \text{ MHz}, t_r = 2.5 \text{ ns}, t_f = 2.5 \text{ ns}$.

Figure 1. Load Circuit and Voltage Waveforms



PARAMETER MEASUREMENT INFORMATION

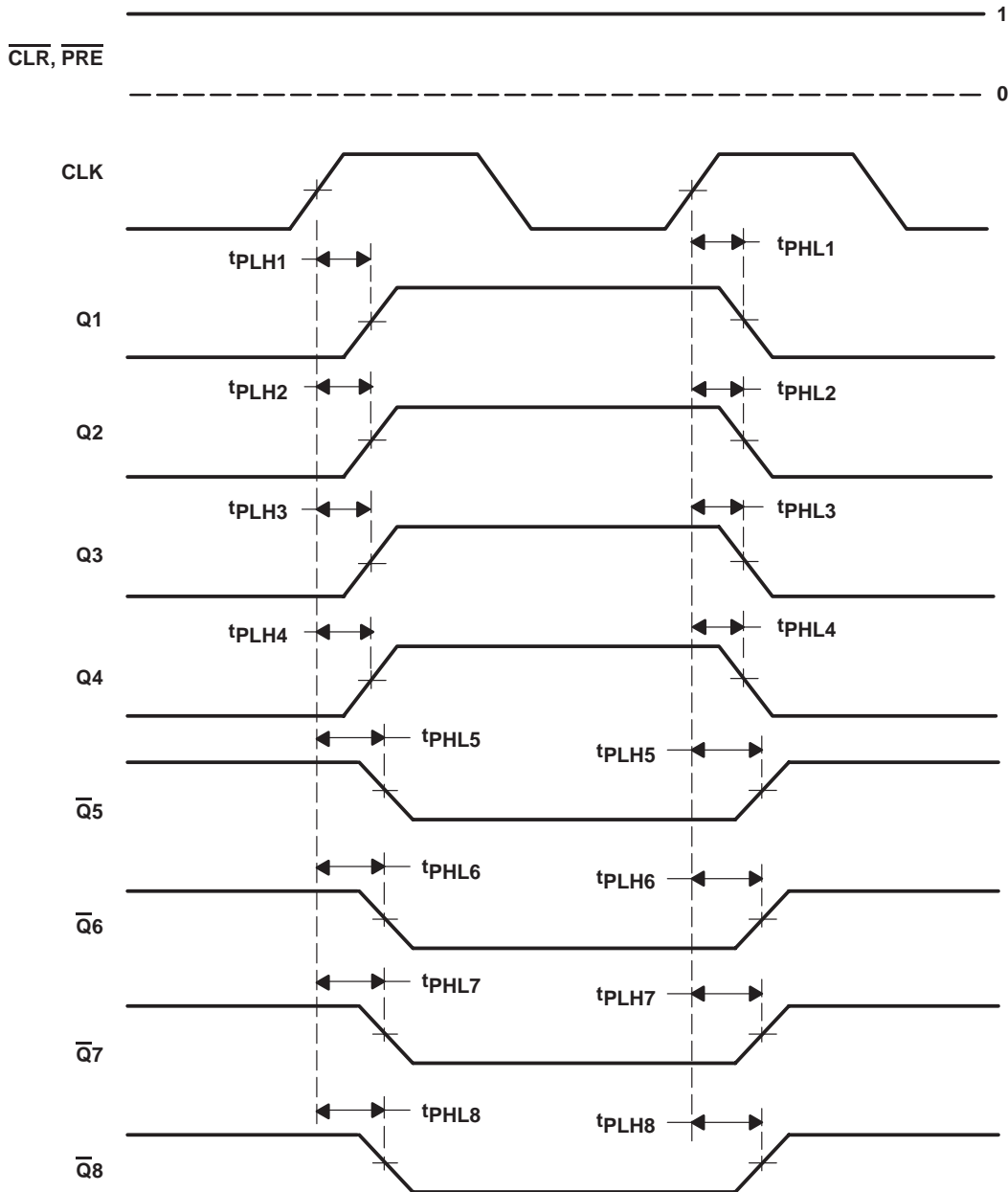

- NOTES: A. $t_{\text{sk}(o)}$ CLK to Q are calculated as the greater of:
- The difference between the fastest and slowest of $t_{\text{PLH}n}$ ($n = 1, 2, 3, 4$)
 - The difference between the fastest and slowest of $t_{\text{PHL}n}$ ($n = 1, 2, 3, 4$)
- B. $t_{\text{sk}(o)}$ CLK to $\overline{\text{Q}}$ are calculated as the greater of:
- The difference between the fastest and slowest of $t_{\text{PLH}n}$ ($n = 5, 6, 7, 8$)
 - The difference between the fastest and slowest of $t_{\text{PHL}n}$ ($n = 5, 6, 7, 8$)
- C. $t_{\text{sk}(o)}$ CLK to Q and $\overline{\text{Q}}$ are calculated as the greater of:
- The difference between the fastest and slowest of $t_{\text{PLH}n}$ ($n = 1, 2, 3, 4$), $t_{\text{PHL}n}$ ($n = 5, 6, 7, 8$)
 - The difference between the fastest and slowest of $t_{\text{PHL}n}$ ($n = 1, 2, 3, 4$), $t_{\text{PLH}n}$ ($n = 5, 6, 7, 8$)
- D. $t_{\text{sk}(p)}$ is calculated as the greater of $|t_{\text{PLH}n} - t_{\text{PHL}n}|$ ($n = 1, 2, 3, \dots, 8$).

Figure 2. Waveforms for Calculation of $t_{\text{sk}(o)}$ and $t_{\text{sk}(p)}$

IMPORTANT NOTICE

Texas Instruments Incorporated and its subsidiaries (TI) reserve the right to make corrections, modifications, enhancements, improvements, and other changes to its products and services at any time and to discontinue any product or service without notice. Customers should obtain the latest relevant information before placing orders and should verify that such information is current and complete. All products are sold subject to TI's terms and conditions of sale supplied at the time of order acknowledgment.

TI warrants performance of its hardware products to the specifications applicable at the time of sale in accordance with TI's standard warranty. Testing and other quality control techniques are used to the extent TI deems necessary to support this warranty. Except where mandated by government requirements, testing of all parameters of each product is not necessarily performed.

TI assumes no liability for applications assistance or customer product design. Customers are responsible for their products and applications using TI components. To minimize the risks associated with customer products and applications, customers should provide adequate design and operating safeguards.

TI does not warrant or represent that any license, either express or implied, is granted under any TI patent right, copyright, mask work right, or other TI intellectual property right relating to any combination, machine, or process in which TI products or services are used. Information published by TI regarding third-party products or services does not constitute a license from TI to use such products or services or a warranty or endorsement thereof. Use of such information may require a license from a third party under the patents or other intellectual property of the third party, or a license from TI under the patents or other intellectual property of TI.

Reproduction of TI information in TI data books or data sheets is permissible only if reproduction is without alteration and is accompanied by all associated warranties, conditions, limitations, and notices. Reproduction of this information with alteration is an unfair and deceptive business practice. TI is not responsible or liable for such altered documentation. Information of third parties may be subject to additional restrictions.

Resale of TI products or services with statements different from or beyond the parameters stated by TI for that product or service voids all express and any implied warranties for the associated TI product or service and is an unfair and deceptive business practice. TI is not responsible or liable for any such statements.

TI products are not authorized for use in safety-critical applications (such as life support) where a failure of the TI product would reasonably be expected to cause severe personal injury or death, unless officers of the parties have executed an agreement specifically governing such use. Buyers represent that they have all necessary expertise in the safety and regulatory ramifications of their applications, and acknowledge and agree that they are solely responsible for all legal, regulatory and safety-related requirements concerning their products and any use of TI products in such safety-critical applications, notwithstanding any applications-related information or support that may be provided by TI. Further, Buyers must fully indemnify TI and its representatives against any damages arising out of the use of TI products in such safety-critical applications.

TI products are neither designed nor intended for use in military/aerospace applications or environments unless the TI products are specifically designated by TI as military-grade or "enhanced plastic." Only products designated by TI as military-grade meet military specifications. Buyers acknowledge and agree that any such use of TI products which TI has not designated as military-grade is solely at the Buyer's risk, and that they are solely responsible for compliance with all legal and regulatory requirements in connection with such use.

TI products are neither designed nor intended for use in automotive applications or environments unless the specific TI products are designated by TI as compliant with ISO/TS 16949 requirements. Buyers acknowledge and agree that, if they use any non-designated products in automotive applications, TI will not be responsible for any failure to meet such requirements.

Following are URLs where you can obtain information on other Texas Instruments products and application solutions:

Products

Amplifiers	amplifier.ti.com
Data Converters	dataconverter.ti.com
DLP® Products	www.dlp.com
DSP	dsp.ti.com
Clocks and Timers	www.ti.com/clocks
Interface	interface.ti.com
Logic	logic.ti.com
Power Mgmt	power.ti.com
Microcontrollers	microcontroller.ti.com
RFID	www.ti-rfid.com
RF/IF and ZigBee® Solutions	www.ti.com/lprf

Applications

Audio	www.ti.com/audio
Automotive	www.ti.com/automotive
Broadband	www.ti.com/broadband
Digital Control	www.ti.com/digitalcontrol
Medical	www.ti.com/medical
Military	www.ti.com/military
Optical Networking	www.ti.com/opticalnetwork
Security	www.ti.com/security
Telephony	www.ti.com/telephony
Video & Imaging	www.ti.com/video
Wireless	www.ti.com/wireless

Mailing Address: Texas Instruments, Post Office Box 655303, Dallas, Texas 75265
Copyright © 2009, Texas Instruments Incorporated