

## +1.8V, Low Power , 16-Bit Sigma - Delta A/D Converter

### FEATURES

- 16-Bit Resolution at Eight Conversions Per Second, Adjustable Down to 10-Bit Resolution at 512 Conversions Per Second
- 1.8V – 5.5V Operation, Low Power Operating .... 260µA ..... Sleep: 0.75µA
- MicroPort™ Serial Bus Requires Only Two Interface Lines
- Uses Internal or External Reference
- Automatically Enters Sleep Mode When Not In Use
- 8-Pin SOIC and 8-Pin PDIP Packages

### TYPICAL APPLICATIONS

- Consumer Electronics, Thermostats, CO Monitors, Humidity Meters, Security Sensors
- Embedded Systems, Data Loggers, Portable Equipment
- Medical Instruments

### GENERAL DESCRIPTION

The TC3400 is a low cost, low power analog-to-digital converter based on TelCom’s Sigma-Delta technology. It will perform 16-bit conversions (15-bit plus sign) at up to eight per second. The TC3400 is optimized for use as a microcontroller peripheral in low cost, battery operated systems. A voltage reference is included, or an external reference can be used.

The TC3400’s 2-wire MicroPort™ digital interface is used for starting conversions and for reading out the data. Driving the SCLK line low starts a conversion. After the conversion starts, each additional falling edge (up to six) detected on SCLK for t4 seconds reduces the A/D resolution by one bit and cuts conversion time in half. After a conversion is completed, clocking the SCLK line puts the MSB through LSB of the resulting data word onto the SDAT line, much like a shift register. The part automatically sleeps when not performing a data conversion.

The TC3400 is available in 8-Pin PDIP and 8-Pin SOIC packages.

### ORDERING INFORMATION

Part No.	Package	Temp. Range
TC3400VPA	8-Pin PDIP (Narrow)	0°C to +85°C
TC3400VOA	8-Pin SOIC (Narrow)	0°C to +85°C

### TYPICAL APPLICATION

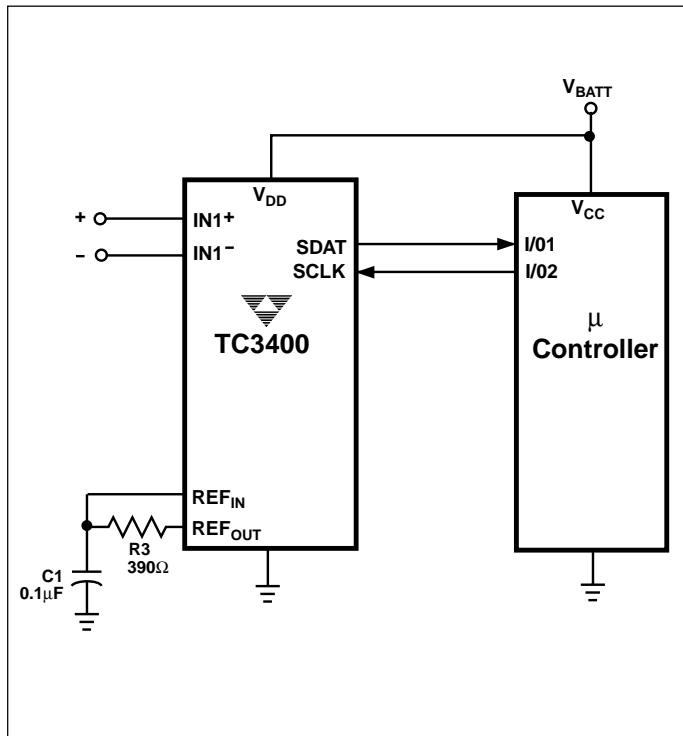

### PIN CONFIGURATIONS

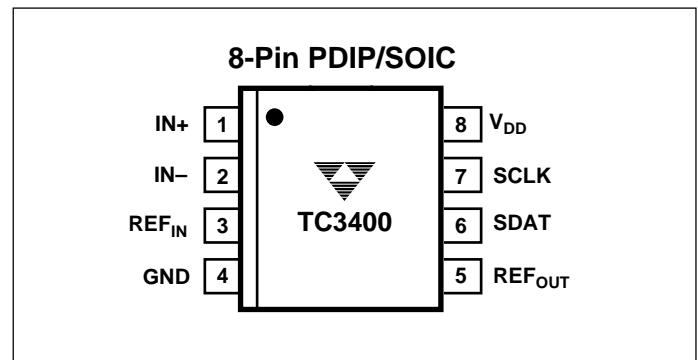

# +1.8V, Low Power , 16-Bit Sigma - Delta A/D Converter

## TC3400

### ABSOLUTE MAXIMUM RATINGS\*

Supply Voltage .....	6.0V
Input Voltage (All Other Pins) .....	(GND – 0.3V) to (V <sub>DD</sub> + 0.3V)
Operating Temperature .....	0°C to 85°C
Maximum Chip Temperature .....	+150°C
Storage Temperature Range .....	– 65°C to +150°C
Lead Temperature (Soldering, 10 sec) .....	+300°C

\*Static-sensitive device. Unused devices must be stored in conductive material. Protect devices from static discharge and static fields. Stresses above those listed under Absolute Maximum Ratings may cause permanent damage to the device. These are stress ratings only and functional operation of the device at these or any other conditions above those indicated in the operational sections of the specifications is not implied. Exposure to Absolute Maximum Rating Conditions for extended periods may affect device reliability.

**DC ELECTRICAL CHARACTERISTICS:** T<sub>A</sub> = 25°C and V<sub>DD</sub> = 2.7V, unless otherwise specified. Specifications in Bold type apply over a temperature range of 0°C to 85°C. V<sub>REF</sub> = 1.25V, Internal Clock Freq = 520kHz

Symbol	Parameter	Test Conditions	Min	Typ	Max	Unit
<b>POWER SUPPLY</b>						
V <sub>DD</sub>	Supply Voltage		1.8	—	5.5	V
I <sub>DD</sub>	Supply Current, During Data Conversion		—	260	—	μA
I <sub>DD(SLEEP)</sub>	Supply Current, Sleep Mode	T <sub>A</sub> = +25°C	—	0.75	1.5	μA
I <sub>DD(SLEEP)</sub>			—	<b>1.2</b>	<b>3.0</b>	μA
<b>ACCURACY (Differential Inputs)</b>						
RES	Resolution		—	16	—	Bits
INL	Integral Non-Linearity	V <sub>DD</sub> = 2.7V	—	.0038	—	%FSR
V <sub>OS</sub>	Offset Error	IN <sup>+</sup> = IN <sup>–</sup> = 0V	—	—	<b>±1.0</b>	%FSR
V <sub>NOISE</sub>	Referred to input		—	60	—	μVrms
CMR	Common Mode Rejection	at DC	—	75	—	dB
FSE	Full Scale Error		—	0.4%	—	%FS
PSRR	Power Supply Rejection Ratio	V <sub>DD</sub> = 2.5V to 3.5V	—	75	—	dB
<b>IN<sup>+</sup>, IN<sup>–</sup></b>						
V <sub>IN±</sub>	Differential Input Voltage	(Note 1)	—	—	2.5	V
	Absolute Voltage Range on IN <sup>+</sup> , IN <sup>–</sup>		GND	—	V <sub>DD</sub>	V
	Input Bias Current		—	1	100	nA
C <sub>IN</sub>	Input Sampling Capacitance		—	2	—	pF
R <sub>IN</sub>	Differential Input Resistance	(Note 2)	—	2.0	—	MΩ
<b>REF<sub>IN</sub>, REF<sub>OUT</sub></b>						
V <sub>REF</sub>	REF <sub>IN</sub> Voltage Range		0	—	1.25	V
I <sub>REF</sub>	REF <sub>IN</sub> Input Current		—	1	—	μA
V <sub>REFOUT</sub>	REF <sub>OUT</sub> Voltage		—	1.193	—	V
REF <sub>SINK</sub>	REF <sub>OUT</sub> Current Sink Capability		—	10	—	μA
REF <sub>SRC</sub>	REF <sub>OUT</sub> Current Source Capability		300	—	—	μA
<b>SCLK</b>						
V <sub>IL</sub>	Input Low Voltage		—	—	<b>0.3 x V<sub>DD</sub></b>	V
V <sub>IH</sub>	Input High Voltage		<b>0.7 x V<sub>DD</sub></b>	—	—	V
I <sub>LEAK</sub>	Leakage Current		—	1	—	μA

Notes: 1. Differential input voltage defined as (V<sub>IN+</sub> – V<sub>IN–</sub>)  
2. Resistance from IN<sub>n+</sub> to IN<sub>n–</sub> or IN<sub>n</sub> to GND.

# +1.8V, Low Power , 16-Bit Sigma - Delta A/D Converter

**TC3400**

**DC ELECTRICAL CHARACTERISTICS (CONT.):**  $T_A = 25^\circ\text{C}$  and  $V_{DD} = 2.7\text{V}$ , unless otherwise specified. Specifications in Bold type apply over a temperature range of  $0^\circ\text{C}$  to  $85^\circ\text{C}$ .

Symbol	Parameter	Test Conditions	Min	Typ	Max	Unit
<b>SDAT</b>						
$V_{OL}$	Output Low Voltage	$I_{OL} = 1.5\text{mA}$	—	—	0.4	V
$V_{OH}$	Output High Voltage (SDAT)	$I_{SOURCE} = 400\mu\text{a}$ (Note 2)	$0.9 \times V_{DD}$	—	—	V

**AC ELECTRICAL CHARACTERISTICS:**  $T_A = 25^\circ\text{C}$  and  $V_{DD} = 2.7\text{V}$ , unless otherwise specified. Specifications in Bold type apply over a temperature range of  $0^\circ\text{C}$  to  $85^\circ\text{C}$ .  $V_{REF} = 1.25\text{V}$ , Internal Clock Freq =  $520\text{kHz}$

Symbol	Parameter	Description	Min	Typ	Max	Unit
$t_1$		Width of SCLK (Negative)	1	—	—	$\mu\text{sec}$
$t_2$	Resolution Reduction Clock Width	Width of SCLK (Positive)	1	—	—	$\mu\text{sec}$
$t_3$	Conversion Time (15-Bit Plus Sign)	16-bit conversion, $T_A = 25^\circ$ (Note 1)	—	125	—	msec
	Conversion Time (14-Bit Plus Sign)	15-bit conversion	—	$t_3/2.0$	—	msec
	Conversion Time (13-Bit Plus Sign)	14-bit conversion	—	$t_3/4.0$	—	msec
	Conversion Time (12-Bit Plus Sign)	13-bit conversion	—	$t_3/7.8$	—	msec
	Conversion Time (11-Bit Plus Sign)	12-bit conversion	—	$t_3/15.1$	—	msec
	Conversion Time (10-Bit Plus Sign)	11-bit conversion	—	$t_3/28.6$	—	msec
	Conversion Time (9-Bit Plus Sign)	10-Bit conversion	—	$t_3/51.4$	—	msec
	$t_4$	Resolution Reduction Window	Width of SCLK	—	$t_3/85.7$	—
$t_5$	SCLK to Data Valid	SCLK falling edge to SDAT valid	<b>1000</b>	—	—	nsec
$t_8$	Acknowledge Delay	SCLK to SDAT delay	—	—	<b>1000</b>	nsec

- Notes: 1. Nominal temperature drift is  $-2830 \text{ ppm}/^\circ\text{C}$  for temperature less than  $25^\circ\text{C}$  and  $-1340 \text{ ppm}/^\circ\text{C}$  for temperatures greater than  $25^\circ\text{C}$ .  
 2. @  $V_{DD} = 1.8\text{V}$ ,  $I_{SOURCE} \leq 200\mu\text{a}$

# +1.8V, Low Power , 16-Bit Sigma - Delta A/D Converter

## TC3400

### PIN DESCRIPTION

TC3400 Pin No.	Name	Description
1	IN <sup>+</sup>	Analog Input. This is the positive terminal of a true differential input consisting of IN <sup>+</sup> and IN <sup>-</sup> . $V_{IN(n)} = (IN^+ - IN^-)$ . (See <i>Electrical Characteristics</i> .)
2	IN <sup>-</sup>	Analog Input. This is the negative terminal of a true differential input consisting of IN <sup>+</sup> and IN <sup>-</sup> . $V_{IN} = (IN^+ - IN^-)$ IN <sup>-</sup> can swing to, but not below, ground. (See <i>Electrical Characteristics</i> .)
3	REF <sub>IN</sub>	Analog Input. The converter's reference voltage is the differential between this pin and ground times two. It may be connected to REF <sub>OUT</sub> as shown on page 1 or scaled using a resistor divider. Any user supplied reference voltage less than 1.25V may be used in place of V <sub>REFOUT</sub> .
4	GND	Ground Terminal.
5	REF <sub>OUT</sub>	Analog Output. The internal reference connects to this pin. It may be scaled externally, if desired, and tied to the REF <sub>IN</sub> input to provide the converter's reference voltage. Care must be taken in connecting external circuitry to this pin. (See <i>Electrical Characteristics</i> .)
6	SDAT	Digital Output (push-pull). This is the MicroPort™ serial data output. SDAT is driven low while the TC3400 is converting data, effectively providing a "busy" signal. After the conversion is complete, every high- to-low transition on the SCLK pin puts a bit from the resulting data word on the SDAT pin (from MSB to LSB).
7	SCLK	Digital Input. This is the MicroPort™ serial clock input. After the conversion starts, each additional falling edge (up to six) detected on SCLK for t <sub>4</sub> seconds reduces the A/D resolution by one bit. When the conversion is complete, the data word can be shifted out on the SDAT pin by clocking the SCLK pin.
8	V <sub>DD</sub>	Power Supply Input. (See <i>Electrical Characteristics</i> .)

### GENERAL THEORY OF OPERATION

The TC3400 is a 16-bit sigma-delta A/D converter with one differential input. The detailed description of the key components of the TC3400 is outlined below. (Also refer to the *A/D Operational Flowchart* on page 9 and the *Timing Diagrams* in Figures 2 through 4).

#### A/D Converter Operation

When the TC3400 is not converting, it is in sleep mode with both the SCLK and SDAT lines high. An A/D conversion is initiated by a high to low transition on the SCLK line at which time the internal clock of the TC3400 is started. Each additional high to low transition of SCLK (following the initial SCLK falling edge) and during the time interval  $t_4$  will decrement the conversion accuracy by one bit and reduce the conversion time by one half. The time interval  $t_4$  is referred to as the resolution reduction window. The minimum conversion resolution is 10 bits so any more than 6 SCLK transitions during  $t_4$  will be ignored.

After each high to low transition of SCLK, in the  $t_4$  interval, the SDAT output is driven high by the TC3400 to acknowledge that the conversion has been decremented. When the SCLK returns high or the  $t_4$  interval ends, the SDAT line returns low (see Figure 2). When the conversion is complete SDAT is driven high. The 3400 now enters sleep mode and the conversion value can be read as a serial data word on the SDAT line.

#### Reading the Data Word

After the conversion is complete and SDAT goes high, the conversion value can be clocked serially onto the SDAT line by high to low transitions of the SCLK. The data word is in two's complement format with the sign bit clocked onto the SDAT line first followed by the MSB and ending in the LSB. For a 16 bit conversion the data word would consist of a sign bit followed by 15 magnitude bits, Table 1 shows the data word versus input voltage for a 16 bit conversion. Note that the full scale input voltage range is  $\pm(2 \text{ REF}_{IN} - 1 \text{ LSB})$ . When  $\text{REF}_{OUT}$  is fed back directly to  $\text{REF}_{IN}$ , an LSB is  $73\mu\text{V}$  for a 16 bit conversion, as  $\text{REF}_{OUT}$  is typically 1.193V.

Figure 3 shows typical SCLK and SDAT waveforms for 16, 12 and 10 bit conversions. Note that any complete convert and read cycle requires 17 negative edge clock pulses. The first is the convert command. Then, up to six of these can occur in the resolution reduction window,  $t_4$ , to decrement accuracy. The remaining pulses clock out the conversion data word.

**Table 1. Data Conversion Word vs. Voltage Input ( $\text{REF}_{IN} = 1.193\text{V}$ )**

Data Word	$\text{INn}^+ - \text{INn}^-$ (Volts)
0111 1111 1111 1111	2.38596 (Positive Full Scale)
0000 0000 0000 0001	$72.8 \text{ E} - 6$
0000 0000 0000 0000	0
1111 1111 1111 1111	$-72.8 \text{ E} - 6$
1000 0000 0000 0001	-2.38596 (Negative Full Scale)
1000 0000 0000 0000	Reserved Code

The SCLK input has a filter which rejects any positive or negative pulse of width less than 50nsec to reduce noise. The rejection width of this pulse can vary between 50nsec and 750nsec depending on processing parameters and supply voltage.

Figure 3 shows a truth table for determining the mode of operation for the TC3400 part by recording the value of SDAT for SCLK in a high, then low, then high state. For example, if SCLK goes through a 1-0-1 transition and the corresponding values of SDAT are 1-1-0, then the SCLK falling edge started a new data conversion. A 0-1-0 for SDAT would have indicated a resolution reduction had occurred. This is useful if the microcontroller has a watchdog reset or otherwise loses track of where the TC3400 part is in the conversion and data readout sequence. The microcontroller can simply transition SCLK until it "finds" a Start Conversion condition.

**+1.8V, Low Power , 16-Bit Sigma -  
Delta A/D Converter**

**TC3400**

**FUNCTIONAL BLOCK DIAGRAM**

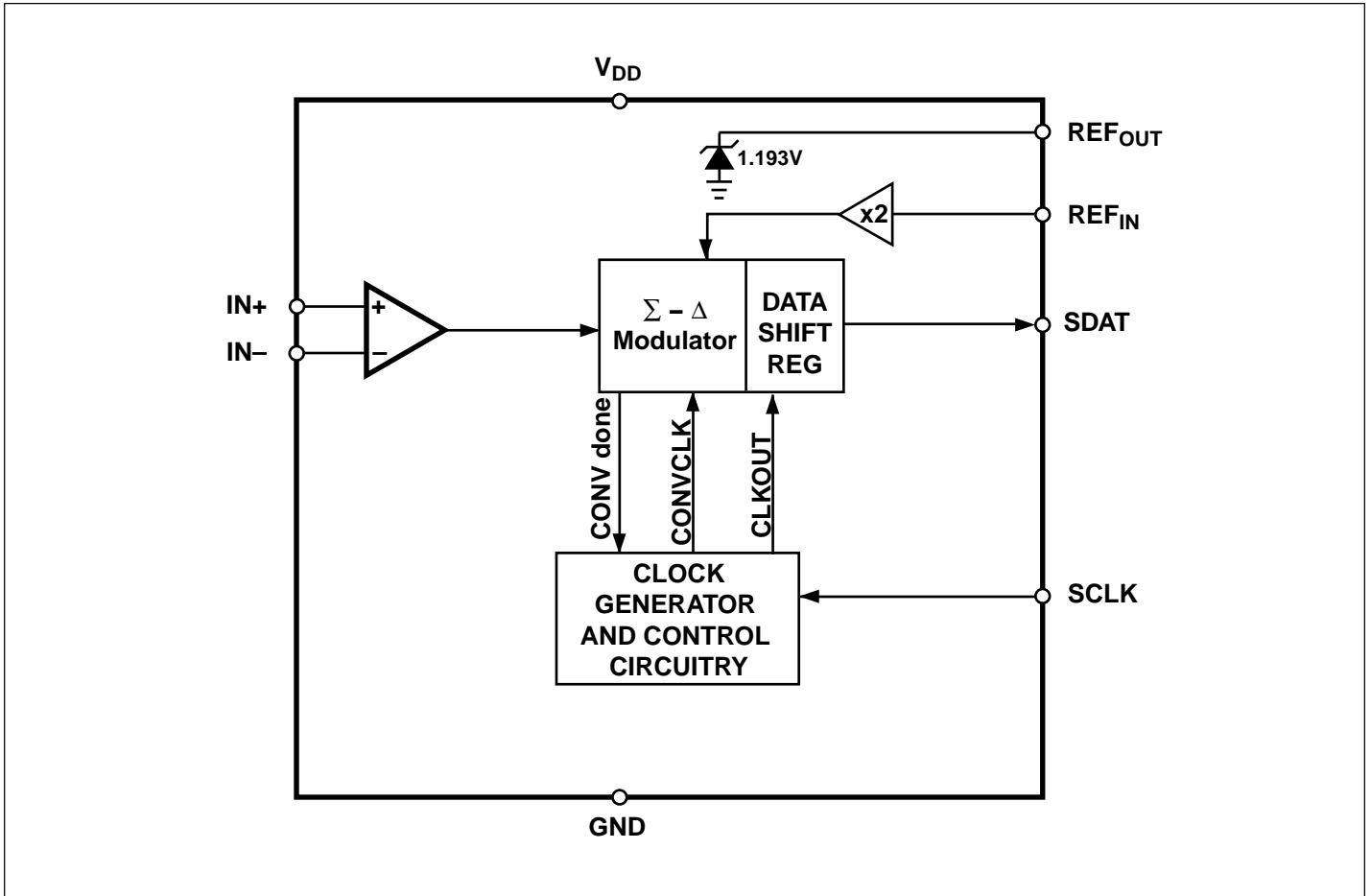

**TIMING DIAGRAMS**

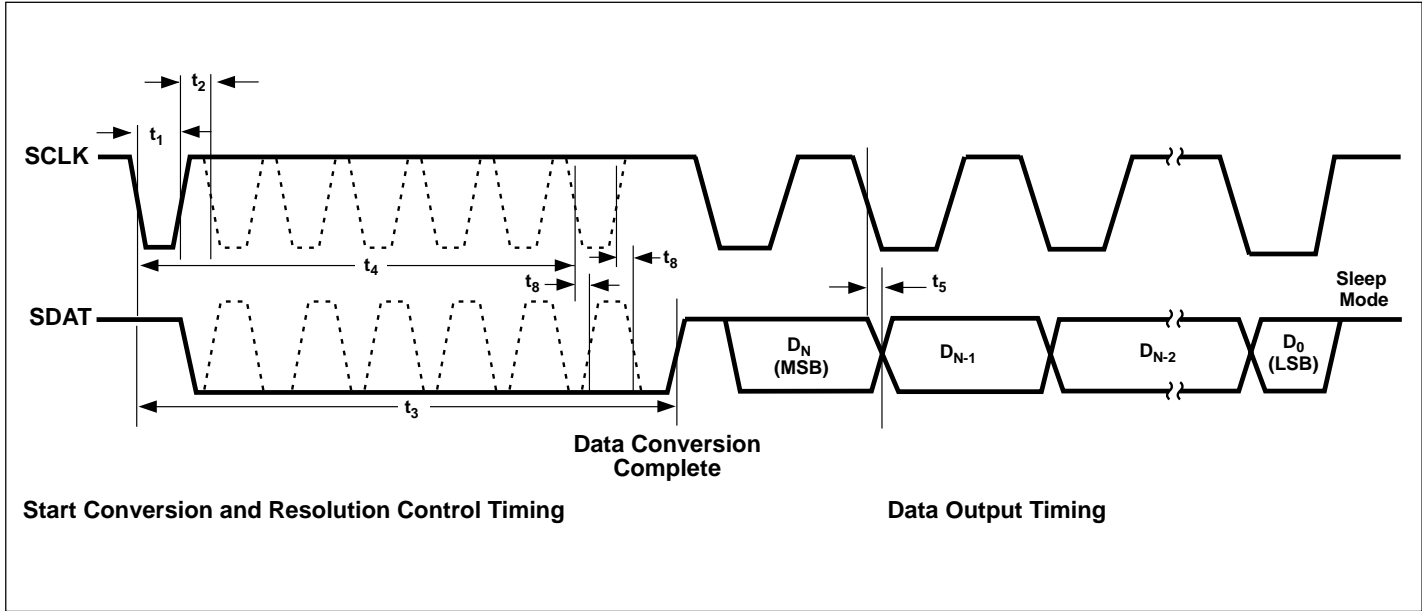

**Figure 2. Conversion and Data Output Timing**

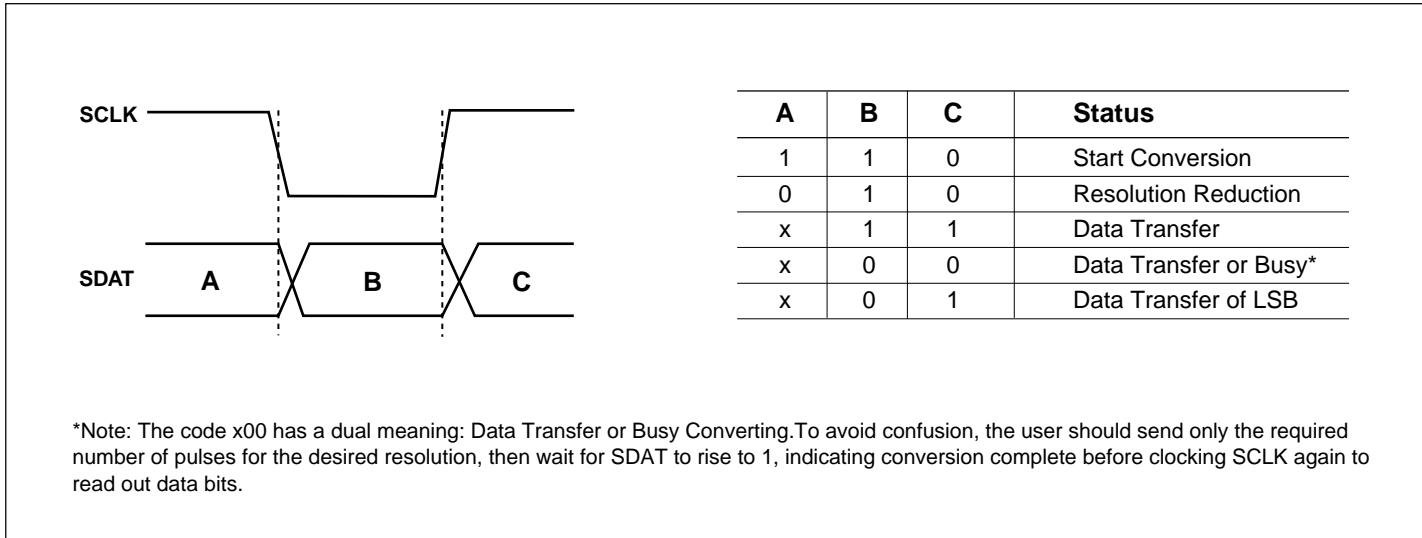

**Figure 3. SCLK, SDAT Logic State Table**

**TC3400**

**TIMING DIAGRAMS (CONT.)**

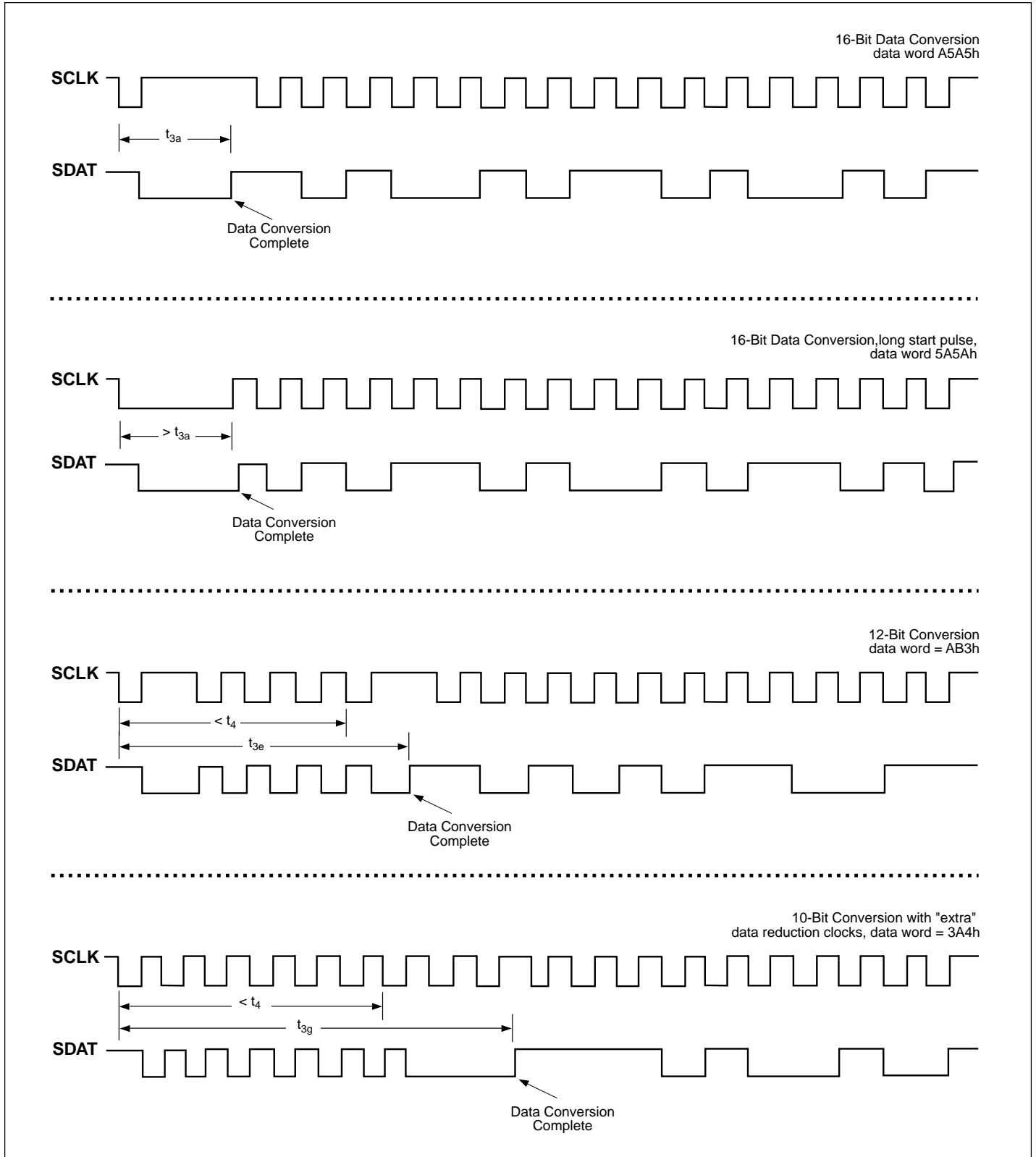

**Figure 4. Example Timing Diagrams**

**A/D OPERATIONAL FLOWCHART**

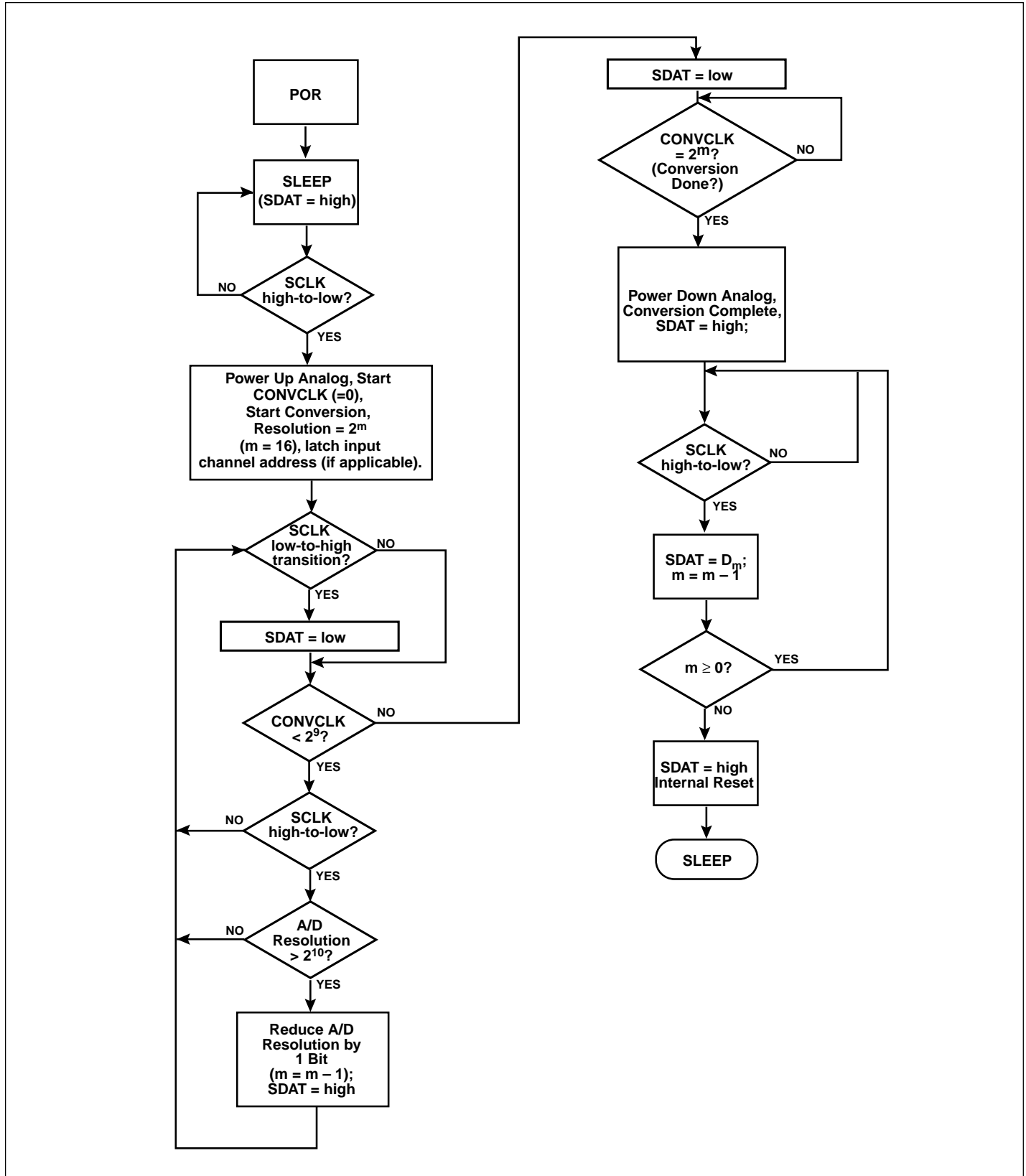

**TC3400**

**TAPING FORM**

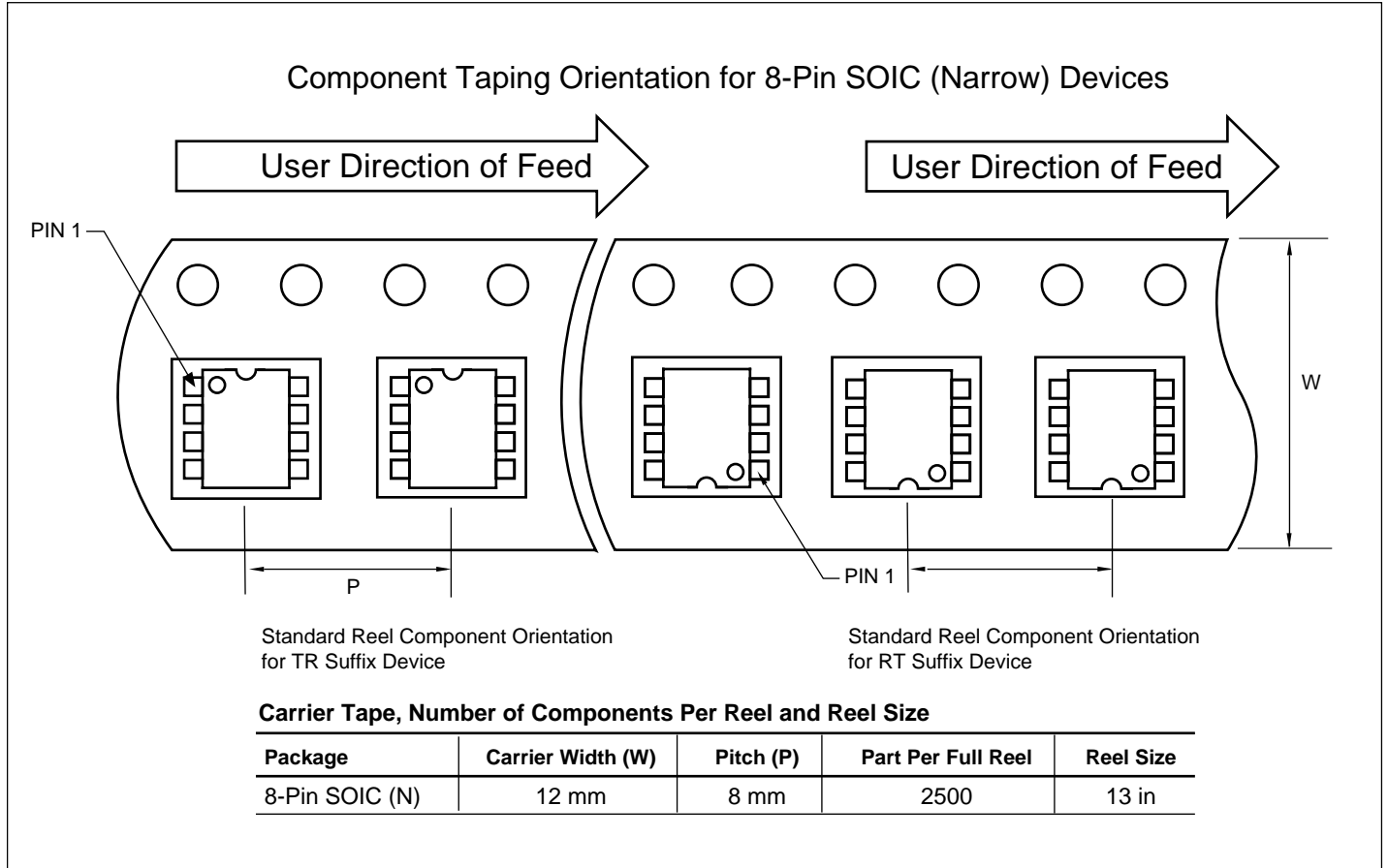

# +1.8V, Low Power , 16-Bit Sigma - Delta A/D Converter

**TC3400**

## PACKAGE DIMENSIONS

### 8-Pin PDIP (Narrow)

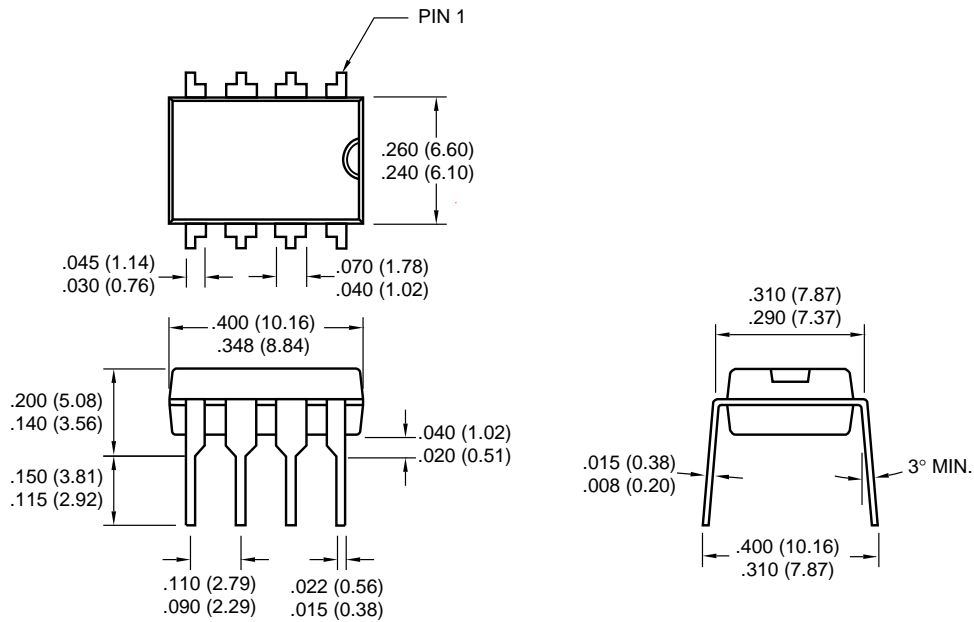

### 8-Pin SOIC (Narrow)

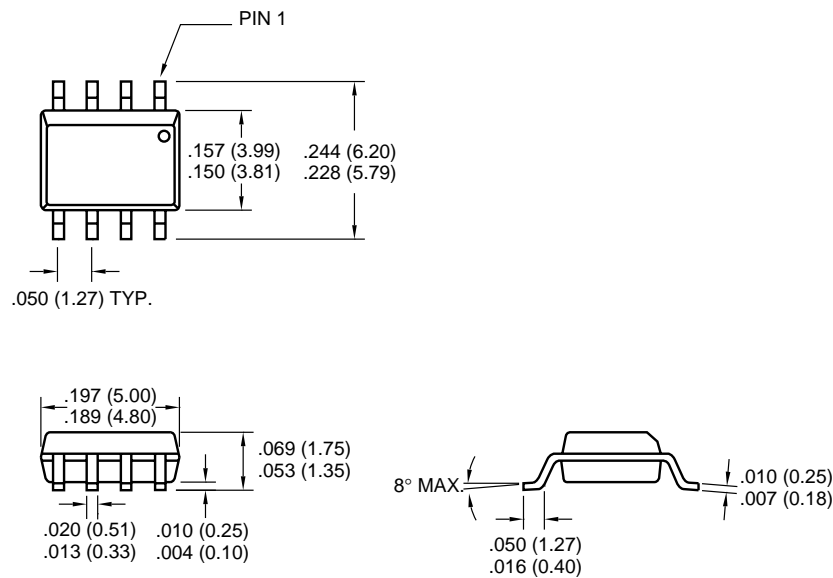

Dimensions: inches(mm)

## Sales Offices

**TelCom Semiconductor, Inc.**  
 1300 Terra Bella Avenue  
 P.O. Box 7267  
 Mountain View, CA 94039-7267  
 TEL: 650-968-9241  
 FAX: 650-967-1590  
 E-Mail: liter@telcom-semi.com

**TelCom Semiconductor, GmbH**  
 Lochhamer Strasse 13  
 D-82152 Martinsried  
 Germany  
 TEL: (011) 49 89 895 6500  
 FAX: (011) 49 89 895 6502 2

**TelCom Semiconductor H.K. Ltd.**  
 10 Sam Chuk Street, Ground Floor  
 San Po Kong, Kowloon  
 Hong Kong  
 TEL: (011) 852-2350-7380  
 FAX: (011) 852-2354-9957