

# 2964B Dynamic Memory Controller

## Product Specification

### Logic Products

#### FEATURES

- Operating Options — controls 16K or 64K DRAMs
- 8-Bit Refresh Counter — refresh address generation, clear input, and selectable terminal count (128 or 256) output
- Row Address Decoder — four Active Row Address Select (RAS) outputs during refresh
- On-Chip Latches — dual 8-bit address latches and RAS decoder latches
- User-Selectable Refresh Modes — burst, distributed or transparent
- 3-port, 8-bit address multiplexer with Schottky speed
- Non-inverting address for RAS and CAS signal paths

#### PRODUCT DESCRIPTION

The Signetics 2964B Dynamic Memory Controller (DMC) provides address multiplexing, refresh address generation, and RAS/CAS control for dynamic RAMs of any data width. The eight-bit address path is designed for 64K DRAMs but can be used equally well with 16K DRAMs. Sixteen address input latches and two row address select latches (for higher order addresses) allow the DMC to control up to 256K words of memory (with 64K DRAMs) by using the internal RAS decoder to select from one-of-four banks of DRAMs.

#### FUNCTIONAL OPERATION

The Signetics 2964B Dynamic Memory Controller (Figure 1) replaces a dozen MSI devices by grouping several unique

functions. Two 8-bit latches capture and hold the memory address. These latches and a clearable, 8-bit refresh counter feed into an 8-bit, 3-input, Schottky speed MUX, for output to the DRAM address lines.

The 2964B also includes a special RAS decoder and CAS buffer. Placing these functions on the same chip minimizes the time skew between output functions which would otherwise be separate MSI chips, and therefore, allows a faster memory cycle time by the amount of skew eliminated.

The RAS Decoder allows upper addresses to select one-of-four banks of DRAM by determining which bank receives an RAS input. During refresh (RFSH = LOW), the decoder mode is changed to four-of-four and all banks of

#### BLOCK DIAGRAM

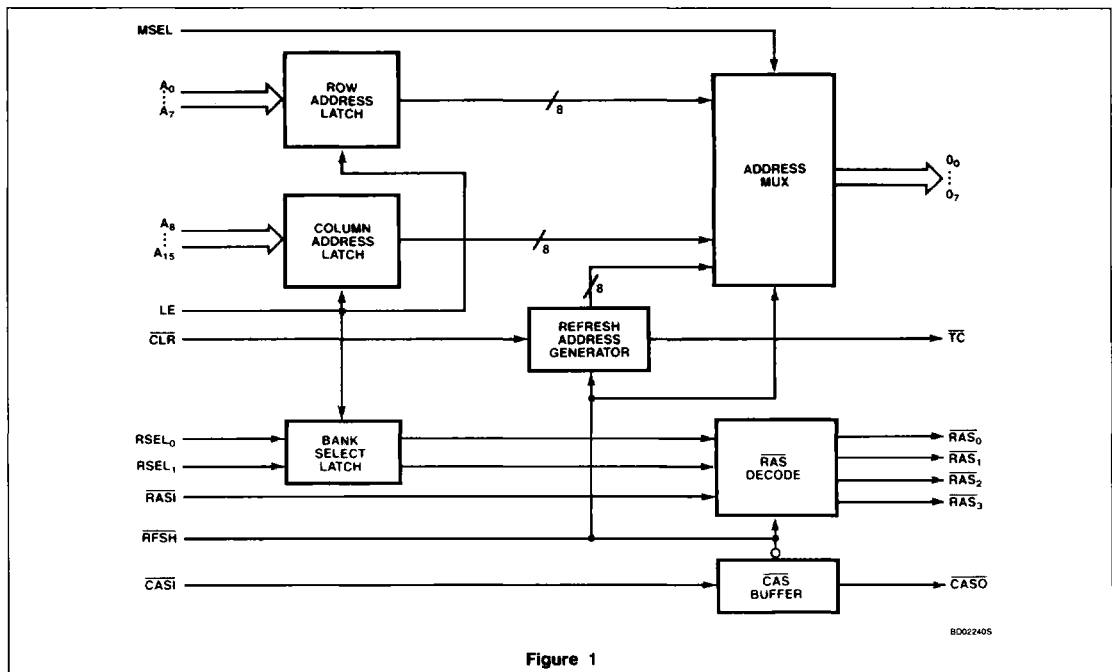
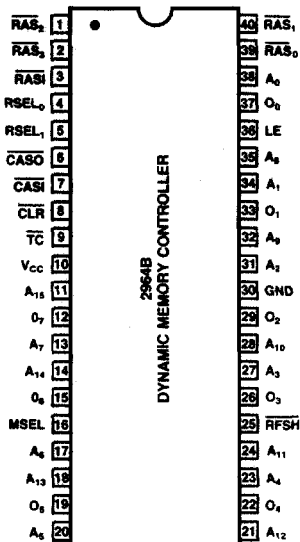

Figure 1

# Dynamic Memory Controller

## 2964B

### 2964B PACKAGE/PIN DESIGNATIONS



PIN NO.	IDENTIFIER	FUNCTION
6	$\overline{\text{CAS0}}$	The Column Address Strobe output. The active LOW $\overline{\text{CAS0}}$ output strobes the Column Address into the dynamic RAM. $\overline{\text{CAS0}}$ is inhibited during refresh ( $\overline{\text{RFSH}} = \text{LOW}$ ).
7	$\overline{\text{CAS1}}$	The Column Address Strobe. An active LOW input at $\overline{\text{CAS1}}$ will result in an active LOW output at $\overline{\text{CAS0}}$ , unless a refresh cycle is in progress ( $\overline{\text{RFSH}} = \text{LOW}$ ).
8	$\overline{\text{CLR}}$	The refresh counter Clear input. An active LOW input at $\overline{\text{CLR}}$ resets the refresh counter to all LOW (refresh address output to all HIGH).
9	$\overline{\text{TC}}$	The Terminal Count output. A LOW output at $\overline{\text{TC}}$ indicates that the refresh counter has been sequenced through either 128 or 256 refresh addresses depending on $A_{15}$ . The $\overline{\text{TC}}$ output remains active LOW until the refresh counter is advanced by the rising edge of $\overline{\text{RAS1}}$ or $\overline{\text{RFSH}}$ .
10	$V_{\text{CC}}$	+5V power supply
11, 14, 18, 21, 24, 28, 32 and 35	$A_{15} - A_8$	The high-order Address inputs are used to latch eight Column Address inputs for the DRAM. These inputs drive the outputs $O_0 - O_7$ when $\text{MSEL}$ is LOW — see next paragraph.

$A_{15}$  is a dual input. With normal TTL level inputs,  $A_{15}$  acts as an address input for 64K DRAMs. If  $A_{15}$  is pulled up to +12V through a 1K resistor, the terminal count output  $\overline{\text{TC}}$  will go LOW every 128 counts (for 16K DRAMs) instead of every 256 counts.

**PIN NO. IDENTIFIER FUNCTION**

1, 2, 39 and 40	$\overline{\text{RAS}}_2, \overline{\text{RAS}}_3, \overline{\text{RAS}}_0, \overline{\text{RAS}}_1$	Row Address Strobe outputs ( $\overline{\text{RAS}}$ ). Each provides a Row Address Strobe for one of the four banks of memory. Each will go active LOW only when selected by $\text{RSEL}_0$ and $\text{RSEL}_1$ and only when $\overline{\text{RAS1}}$ goes active LOW. All $\overline{\text{RAS}}_{0,3}$ outputs go active low in response to $\overline{\text{RAS1}}$ when $\overline{\text{RFSH}}$ goes LOW.
3	$\overline{\text{RAS1}}$	The Row Address Strobe input. During normal memory cycles, the selected $\overline{\text{RAS}}$ Decoder output, $\overline{\text{RAS}}_0, \overline{\text{RAS}}_1, \overline{\text{RAS}}_2$ or $\overline{\text{RAS}}_3$ , will go active LOW in response to an active LOW input at $\overline{\text{RAS1}}$ . During refresh ( $\overline{\text{RFSH}} = \text{LOW}$ ), all $\overline{\text{RAS}}$ outputs go LOW in response to $\overline{\text{RAS1}} = \text{LOW}$ .
4 and 5	$\text{RSEL}_0$ and $\text{RSEL}_1$	The $\overline{\text{RAS}}$ decoder Select inputs. Data (latched) at these inputs (normally higher-order addresses) is decoded by the $\overline{\text{RAS}}$ Decoder to " $\overline{\text{RAS}}$ Select" one of four banks of memory with $\overline{\text{RAS}}_0, \overline{\text{RAS}}_1, \overline{\text{RAS}}_2$ or $\overline{\text{RAS}}_3$ .

12, 15, 19, 22, 26, 29, 33 and 37	$O_7 - O_0$	The DRAM address outputs. The eight-bit width is designed for DRAMs up to 64K.
13, 17, 20, 23, 27, 31, 34 and 38	$A_7 - A_0$	The low-order Address inputs are used to latch eight Row Address inputs for the DRAM. These inputs drive the outputs $O_0 - O_7$ when $\text{MSEL}$ is HIGH.
16	$\text{MSEL}$	The Multiplexer-SElect input determines whether low-order or high-order address inputs appear at the multiplexer outputs $O_0 - O_7$ . When $\text{MSEL}$ is HIGH, the low-order address latches ( $A_0 - A_7$ ) are connected to the outputs. When $\text{MSEL}$ is LOW, the high-order address latches are connected to the outputs.

# Dynamic Memory Controller

# 2964B

## 2964B PACKAGE/PIN DESIGNATIONS (Continued)

PIN NO.	IDENTIFIER	FUNCTION	PIN NO.	IDENTIFIER	FUNCTION
25	$\overline{\text{RFSH}}$	The Refresh control input. When active LOW, the $\overline{\text{RFSH}}$ input switches the address output multiplexer to output the inverted contents of the 8-bit refresh counter. $\overline{\text{RFSH}}$ LOW also inhibits the $\overline{\text{CAS}}$ buffer and changes the mode of the $\overline{\text{RAS}}$ decoder from one-of-four to four-of-four so that all four $\overline{\text{RAS}}$ decoder outputs, $\overline{\text{RAS}}_0$ , $\overline{\text{RAS}}_1$ , $\overline{\text{RAS}}_2$ and $\overline{\text{RAS}}_3$ , go LOW in response to a LOW input at $\overline{\text{RAS}}_i$ . This action refreshes one row address in each of the four $\overline{\text{RAS}}$ decoded memory banks. The refresh counter is advanced at the end of each cycle by the LOW-to-HIGH transition of $\overline{\text{RFSH}}$ or $\overline{\text{RAS}}_i$ (whichever occurs first). In burst mode refresh, $\overline{\text{RFSH}}$ may be held LOW and refresh accompanied by toggling $\overline{\text{RAS}}_i$ .	30	GND	Ground.
			36	LE	The address latch enable input. An active HIGH input at LE causes the two 8-bit address latches and the 2-bit $\overline{\text{RAS}}$ Select input latch to go transparent, accepting new input data. A LOW input on LE latches the input data which meets set-up and hold time requirements.

memory receive an RAS input for refresh in response to an  $\overline{\text{RAS}}_i$  active LOW input.  $\overline{\text{CAS}}$  is inhibited during refresh.

Burst mode refresh is accomplished by holding  $\overline{\text{RFSH}}$  low and toggling  $\overline{\text{RAS}}_i$ .

$A_{15}$  is a dual function input which controls the refresh counter's range. For 64K DRAMs, it is

an address input. For 16K DRAMs, it can be pulled to +12V through 1K to terminate the refresh count at 128 instead of 256.

### TRUTH TABLES: $\overline{\text{RAS}}$ OUTPUT FUNCTIONS

$\overline{\text{RFSH}}$	$\overline{\text{RAS}}_i$	$\overline{\text{RSEL}}_1$	$\overline{\text{RESEL}}_0$	$\overline{\text{RAS}}_0$	$\overline{\text{RAS}}_1$	$\overline{\text{RAS}}_2$	$\overline{\text{RAS}}_3$
L	H	X	X	H	H	H	H
L	L	X	X	L	L	L	L
H	H	X	X	H	H	H	H
H	L	L	L	L	H	H	H
H	L	L	H	H	L	H	H
H	L	H	L	H	H	L	H
H	L	H	H	H	H	H	L

### $\overline{\text{CASO}}$ FUNCTION

$\overline{\text{RFSH}}$	$\overline{\text{CAS}}_i$	$\overline{\text{CASO}}$
H	L	L
H	H	H
L	X	H

### ADDRESS OUTPUT FUNCTIONS

MSEL	$\overline{\text{RFSH}}$	$0_0 - 0_7$
H	H	$A_0 - A_7$
L	H	$A_8 - A_{15}$
X	L	Refresh Address



## Dynamic Memory Controller

2964B

## REFRESH ADDRESS COUNTER FUNCTION

A <sub>15</sub>	CLR	RFSH	RAS <sub>i</sub>	TC	REFRESH COUNT	FUNCTION
X	L	X	X	X	FF <sub>H</sub>	Clear counter
X	H		X	X	NC	Output refresh address no change for counter
X	H		L	X	Count - 1	Return to memory cycle mode and decrement counter
X	H	L		X	NC	Output all RAS <sub>i</sub> to RAM no change for counter
X	H	L		X	Count - 1	Return RAS <sub>i</sub> to HIGH and decrement counter
L or H	H	X	X	L	00 <sub>H</sub>	Terminal count for 256 line refresh
+12V*	H	X	X	L	00 <sub>H</sub> and 80 <sub>H</sub>	Terminal count for 128 line refresh

\*Through 1K $\Omega$  resistor.

## ABSOLUTE MAXIMUM RATINGS (Above which useful life may be impaired)

Storage temperature	-65 to +150°C
Temperature (ambient) under bias	-55 to +125°C
Supply voltage to ground potential	-0.5 to +7.0V
DC voltage applied to outputs for high output state	+0.5V to +V <sub>CC</sub> MAX
DC input voltage	-0.5 to 5.5V
DC output current, into outputs	30mA
DC input current	-30 to +5.0mA

## Dynamic Memory Controller

2964B

**DC ELECTRICAL CHARACTERISTICS** Commercial:  $T_A = 0$  to  $+70^\circ\text{C}$ ,  $V_{CC} = 5.0\text{V}$  ( $\pm 5\%$ ), (Min = 4.75V), (Max = 5.25V)

DESCRIPTION	TEST CONDITIONS <sup>1</sup>		2964B			UNIT
			Min	Typ <sup>2</sup>	Max	
$V_{OH}$ Output HIGH voltage	$V_{CC} = \text{MIN}$ $V_{IN} = V_{IH}$ or $V_{IL}$ $I_{OH} = -1\text{mA}$	$\overline{TC}$	2.5			V
		Others	3.0			V
$V_{OH}$ Output HIGH voltage	$V_{CC} = \text{MIN}$ $V_{IN} = V_{IH}$ or $V_{IL}$ $I_{OH} = -15\text{mA}$	All outputs except $\overline{TC}$	2.0			V
$V_{OL}$ Output LOW voltage	$V_{CC} = \text{MIN}$ $V_{IN} = V_{IH}$ or $V_{IL}$	All outputs except $\overline{TC}$ , $I_{OL} = 16\text{mA}$			0.5	V
		$\overline{TC}$ , $I_{OL} = 8\text{mA}$			0.5	V
$V_{IH}$ Input HIGH level	Guaranteed input logical HIGH voltage for all inputs		2.0			V
$V_{IL}$ Input LOW level	Guaranteed input logical LOW voltage for all inputs				0.8	V
$V_I$ Input clamp voltage	$V_{CC} = \text{MIN}$ , $I_{IN} = -18\text{mA}$				-1.5	V
$I_{IL}$ Input LOW current	$V_{CC} = \text{MAX}$ $V_{IN} = 0.4\text{V}$	$\overline{RAS}$			-3.2	mA
		$\overline{CAS}$ , MSEL, RFSH			-1.6	mA
		$A_0 - A_{15}$ , $\overline{CLR}$ RSEL <sub>0,1</sub> , LE			-0.4	mA
$I_{IH}$ Input HIGH current	$V_{CC} = \text{MAX}$ $V_{IN} = 2.7\text{V}$	$\overline{RAS}$			100	$\mu\text{A}$
		$\overline{CAS}$ , MSEL, RFSH			50	$\mu\text{A}$
		$A_0 - A_{15}$ , $\overline{CLR}$ RSEL <sub>0,1</sub> , LE			20	$\mu\text{A}$
$I_I$ Input HIGH current	$V_{CC} = \text{MAX}$ $V_{IN} = -5.5\text{V}$	$\overline{RAS}$			2.0	mA
		$\overline{CAS}$ , MSEL, RFSH			1.0	mA
	$V_{CC} = \text{MAX}$ $V_{IN} = 5.5\text{V}$	$A_0 - A_{15}$ , $\overline{CLR}$ RSEL <sub>0,1</sub> , LE			0.1	mA
$I_{SC}$ Output short circuit current	$V_{CC} = \text{MAX}$ (note 3)		-40		-100	mA
$I_{CC}$ Power supply current (note 4)	25°C, 5V	Com'l		122		mA
	0 to 70°C				173	mA
	70°C				185	mA
$I_T$ A <sub>15</sub> Enable current	A <sub>15</sub> connected to +12V through 1K $\Omega$ $\pm 10\%$				5	mA

**NOTES:**

- For conditions shown as MIN or MAX, use the appropriate value specified under DC Electrical Characteristics for the applicable device type.
- Typical limits are at  $V_{CC} = 5.0\text{V}$ , 25°C ambient and maximum loading.
- Not more than one output should be shorted at a time. Duration of the short circuit test should not exceed one second.
- $I_{CC}$  is worst case when the Address inputs are latched HIGH, the refresh counter is at terminal count (255),  $\overline{RAS}$  and  $\overline{CAS}$  are HIGH and all other inputs are LOW.

## Dynamic Memory Controller

2964B

**AC ELECTRICAL CHARACTERISTICS**

Tables 1 and 2 specify performance characteristics of the Signetics 2964B over the

operating range for capacitive loads of 50 and 150 picofarads, respectively. Note that the minimum specified limits for  $t_{PW}$ ,  $t_S$ , and  $t_H$  are for minimum system operating require-

ments and that limits for  $t_{SKEW}$  and  $t_{PD}$  are guaranteed test limits for the device. All AC parameters are specified at 1.5 volts.

**Table 1. Performance Characteristics for Capacitive Loading of 50 Picofarads**

PARAMETER — See Figure 2.	DESCRIPTION	COMMERCIAL		UNIT	
		$T_A = +25^\circ\text{C}$ $V_{CC} = 5.0\text{V}$			
		$T_A = 0^\circ\text{C to } +70^\circ\text{C}$ $V_{CC} = 5.0\text{V} \pm 5\%$			
		Typ	Min	Max	
1 $t_{PD}$	$A_i$ to $O_i$ Delay	14		19	ns
2 $t_{PHL}$	$\overline{RAS}_i$ to $\overline{RAS}_i$ ( $\overline{RFSH} = H$ )	14		20	ns
3 $t_{PHL}$	$\overline{RAS}_i$ to $\overline{RAS}_i$ ( $\overline{RFSH} = L$ )	14		20	ns
4 $t_{PD}$	MSEL to $O_i$	17	9		ns
5 $t_{PD}$	MSEL to $O_i$	17		21	ns
6 $t_{PHL}$	$\overline{CAS}_i$ to $\overline{CAS}_i$ ( $\overline{RFSH} = H$ )	12		17	ns
7 $t_{PHL}$	RSEL <sub>i</sub> to $\overline{RAS}_i$ (LE = H, $\overline{RAS}_i = L$ )	15		20	ns
8 $t_{PLH}$	$\overline{RFSH}$ to $\overline{TC}$ ( $\overline{RAS}_i = L$ )	30		40	ns
9 $t_{PLH}$	$\overline{RAS}_i$ to $\overline{TC}$ ( $\overline{RFSH} = L$ )	25		35	ns
10 $t_{PW}$	$\overline{RAS}_i = L$ ( $\overline{RFSH} = L$ )	10	50		ns
11 $t_{PW}$	$\overline{RAS}_i = H$ ( $\overline{RFSH} = L$ )	10	50		ns
12 $t_{PD}$	$\overline{RFSH}$ to $O_i$ ( $\overline{RAS}_i = X$ )	17		21	ns
13 $t_{PHL}$	$\overline{RFSH}$ to $\overline{RAS}_i$ ( $\overline{RAS}_i = L$ )	19		26	ns
14 $t_{PW}$	$\overline{CLR} = L$	10	30		ns
15 $t_{PLH}$	$\overline{RFSH}$ to $\overline{CAS}_i$ ( $\overline{RAS}_i = L$ , $\overline{CAS}_i = L$ , Note 1)	16		21	ns
16 $t_{PD}$	LE to $O_i$	25		35	ns
17 $t_{PHL}$	LE to $\overline{RAS}_i$	30		40	ns
18 $t_{PLH}$	$\overline{CLR}$ to $\overline{TC}$	35		45	ns
19 $t_{PLH}$	$\overline{CLR}$ to $O_i$ ( $\overline{RFSH} = L$ )	31		44	ns
20 $t_S$	$A_i$ to LE Set-up time	0	5		ns
21 $t_H$	$A_i$ to LE Hold time	5	12		ns
22 $t_S$	RSEL <sub>i</sub> to LE Set-up time	0	5		ns
23 $t_H$	RSEL <sub>i</sub> to LE Hold time	10	17		ns
24 $t_S$	$\overline{CLR}$ Recovery time	10	16		ns
25 $t_{SKEW}$	$O_i$ to $\overline{RAS}_i$ ( $\overline{RFSH} = H$ , Note 2)	2		5	ns
26 $t_{SKEW}$	$O_i$ to $\overline{CAS}_i$ (Note 2)	6		8	ns
27 $t_{SKEW}$	$O_i$ to $\overline{RAS}_i$ ( $\overline{RFSH} = L$ , Note 3)	6		8	ns
28 $t_{SKEW}$	$O_i$ to $\overline{RAS}_i$ (MSEL = Z, Note 4)	1		5	ns

## Dynamic Memory Controller

2964B

## AC ELECTRICAL CHARACTERISTICS (Continued)

Table 2. Performance Characteristics for Capacitive Loading of 150 Picofarads

PARAMETER — See Figure 2.	DESCRIPTION	COMMERCIAL		UNIT	
		$T_A = 0^\circ\text{C to } +70^\circ\text{C}$ $V_{CC} = 5.0\text{V} \pm 5\%$			
		Typ	Min    Max		
1 $t_{PD}$	$A_i$ to $O_i$ Delay	20		25	ns
2 $t_{PHL}$	$\overline{RAS}_i$ to $\overline{RAS}_i$ ( $\overline{RFSH} = H$ )	18		24	ns
3 $t_{PHL}$	$\overline{RAS}_i$ to $\overline{RAS}_i$ ( $\overline{RFSH} = L$ )	18		24	ns
4 $t_{PD}$	MSEL to $O_i$	23	12		ns
5 $t_{PD}$	MSEL to $O_i$	23		27	ns
6 $t_{PHL}$	$\overline{CAS}_i$ to $\overline{CAS}_i$ ( $\overline{RFSH} = H$ )	17		24	ns
7 $t_{PHL}$	RSEL <sub>i</sub> to $\overline{RAS}_i$ (LE = H, $\overline{RAS}_i = L$ )	19		27	ns
8 $t_{PLH}$	$\overline{RFSH}$ to $\overline{TC}$ ( $\overline{RAS}_i = L$ )	34		45	ns
9 $t_{PLH}$	$\overline{RAS}_i$ to $\overline{TC}$ ( $\overline{RFSH} = L$ )	32		45	ns
10 $t_{PW}$	$\overline{RAS}_i = L$ ( $\overline{RFSH} = L$ )	10	50		ns
11 $t_{PW}$	$\overline{RAS}_i = H$ ( $\overline{RFSH} = L$ )	10	50		ns
12 $t_{PD}$	$\overline{RFSH}$ to $O_i$ ( $\overline{RAS}_i = X$ )	21		27	ns
13 $t_{PHL}$	$\overline{RFSH}$ to $\overline{RAS}_i$ ( $\overline{RAS}_i = L$ )	25		33	ns
14 $t_{PW}$	$\overline{CLR} = L$	10	30		ns
15 $t_{PLH}$	$\overline{RFSH}$ to $\overline{CAS}_i$ ( $\overline{RAS}_i = L$ , $\overline{CAS}_i = L$ , Note 1)	21		27	ns
16 $t_{PD}$	LE to $O_i$	30		40	ns
17 $t_{PHL}$	LE to $\overline{RAS}_i$	34		45	ns
18 $t_{PLH}$	$\overline{CLR}$ to $\overline{TC}$	39		55	ns
19 $t_{PLH}$	$\overline{CLR}$ to $O_i$ ( $\overline{RFSH} = L$ )	38		50	ns
20 $t_s$	$A_i$ to LE Set-up time	0	5		ns
21 $t_h$	$A_i$ to LE Hold time	5	12		ns
22 $t_s$	RSEL <sub>i</sub> to LE Set-up time	0	5		ns
23 $t_h$	RSEL <sub>i</sub> to LE Hold time	10	17		ns
24 $t_s$	$\overline{CLR}$ Recovery time	10	16		ns
25 $t_{SKEW}$	$O_i$ to $\overline{RAS}_i$ ( $\overline{RFSH} = H$ , Note 2)	3		6	ns
26 $t_{SKEW}$	$O_i$ to $\overline{CAS}_i$ (note 2)	6		8	ns
27 $t_{SKEW}$	$O_i$ to $\overline{RAS}_i$ ( $\overline{RFSH} = L$ , Note 3)	6		9	ns
28 $t_{SKEW}$	$O_i$ to $\overline{RAS}_i$ (MSEL $\overline{L}$ , Note 4)	1		5	ns

## NOTES:

- $\overline{RFSH}$  inhibits  $\overline{CAS}_i$  during refresh. Specification is for  $\overline{CAS}_i$  inhibit time.
- $O_i$  to  $\overline{RAS}_i$  ( $\overline{RFSH} = \text{HIGH}$ ) skew is guaranteed maximum difference between fastest  $\overline{RAS}_i$  to  $\overline{RAS}_i$  delay and slowest  $A_i$  to  $O_i$  delay within a single device.  $O_i$  to  $\overline{CAS}_i$  skew is maximum difference between fastest  $\overline{CAS}_i$  to  $\overline{CAS}_i$  delay and slowest MSEL to  $O_i$  delay within a single device. See application section entitled Memory Cycle Timing for correlation to System Timing requirements.
- $O_i$  to  $\overline{RAS}_i$  ( $\overline{RFSH} = \text{LOW}$ ) skew is guaranteed maximum difference between fastest  $\overline{RAS}_i$  to  $\overline{RAS}_i$  delay and slowest  $\overline{RFSH}$  to  $O_i$  delay within a single device. See application section on Refresh Timing for correlation to system refresh timing requirements.
- $O_i$  to  $\overline{RAS}_i$  (MSEL  $\overline{L}$ ) skew is guaranteed maximum difference between fastest MSEL  $\overline{L}$  to  $O_i$  delay and slowest  $\overline{RAS}_i$  to  $\overline{RAS}_i$  delay within a single device.

# Dynamic Memory Controller

2964B

## TIMING DIAGRAM

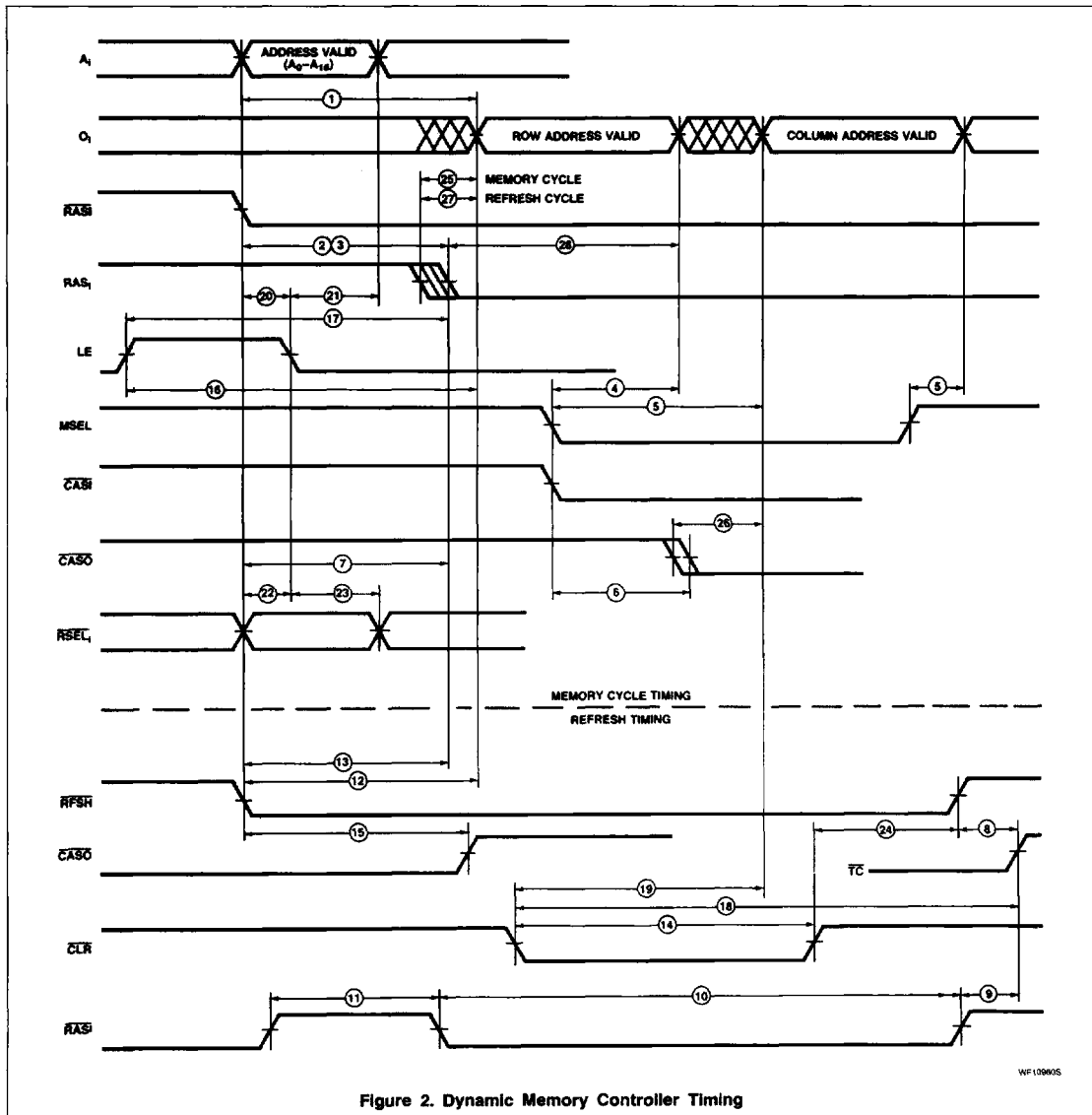

Figure 2. Dynamic Memory Controller Timing

WF109605

# Dynamic Memory Controller

2964B

## MEMORY CYCLE TIMING

The relationship between DMC specifications and system timing requirements are shown in Figure 3.  $T_1$ ,  $T_2$ , and  $T_3$  represent the minimum timing requirements at the DMC inputs

to guarantee that DRAM timing requirements are met and that maximum system performance is achieved.

The minimum requirements for  $T_1$ ,  $T_2$ , and  $T_3$  are as follows:

$$T_1 \text{ MIN} = t_{RAH} + t_{28}$$

$$T_2 \text{ MIN} = t_1 + t_{26} + t_{ASC}$$

$$T_3 \text{ MIN} = t_{ASR} + t_{25} \text{ where,}$$

$t_{RAH}$  = Row Address Hold Time  
 $t_{ASC}$  = Column Address Set-up Time  
 $t_{ASR}$  = Row Address Set-up Time

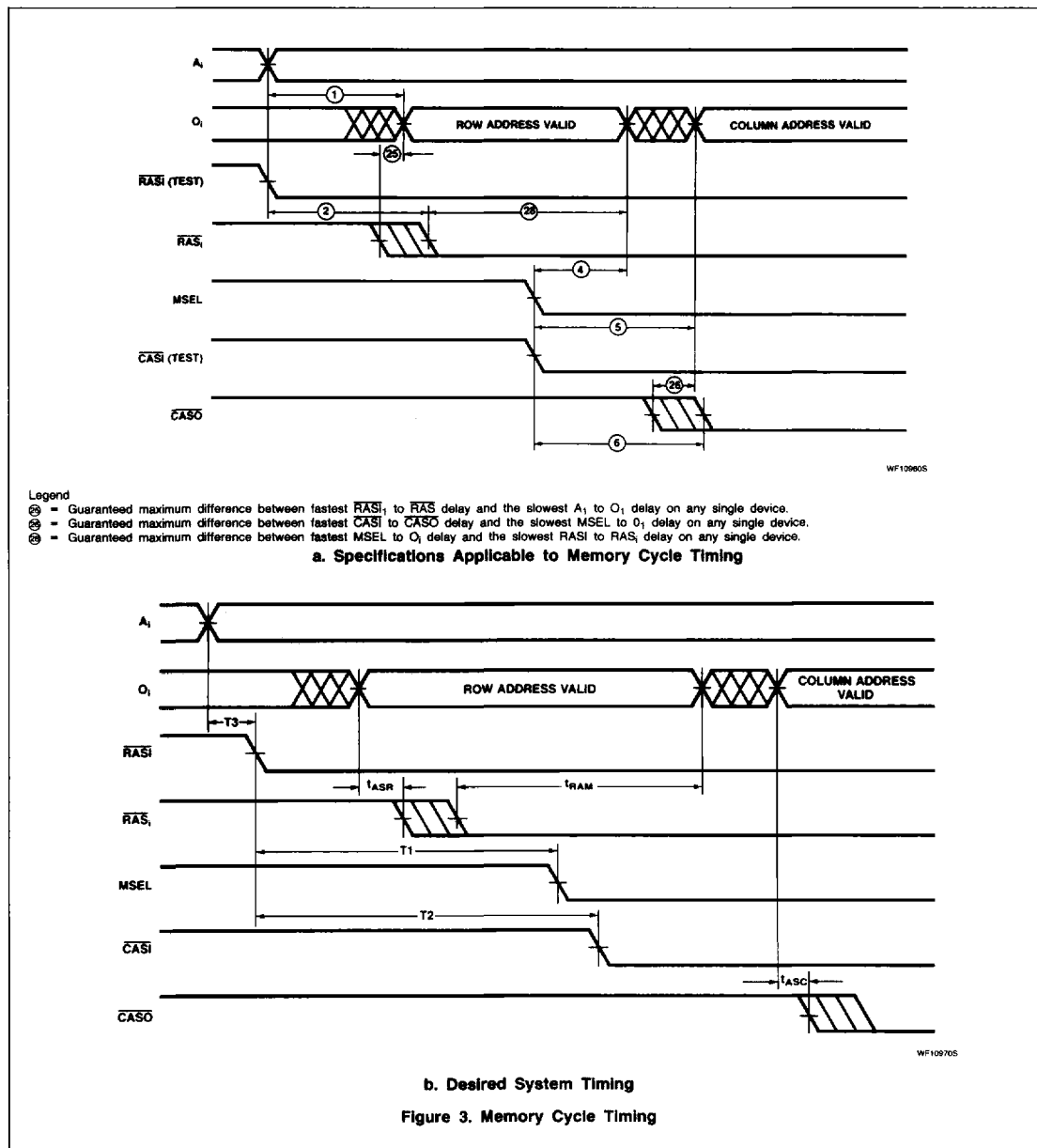

# Dynamic Memory Controller

2964B

## REFRESH CYCLE TIMING

The timing relationships for refresh are shown in Figure 4.

$T_4$  minimum is calculated as follows:

$$T_4 = t_{ASR} + t_{27}$$

Burst refresh timing is shown in Figure 5.

## AC WAVEFORMS

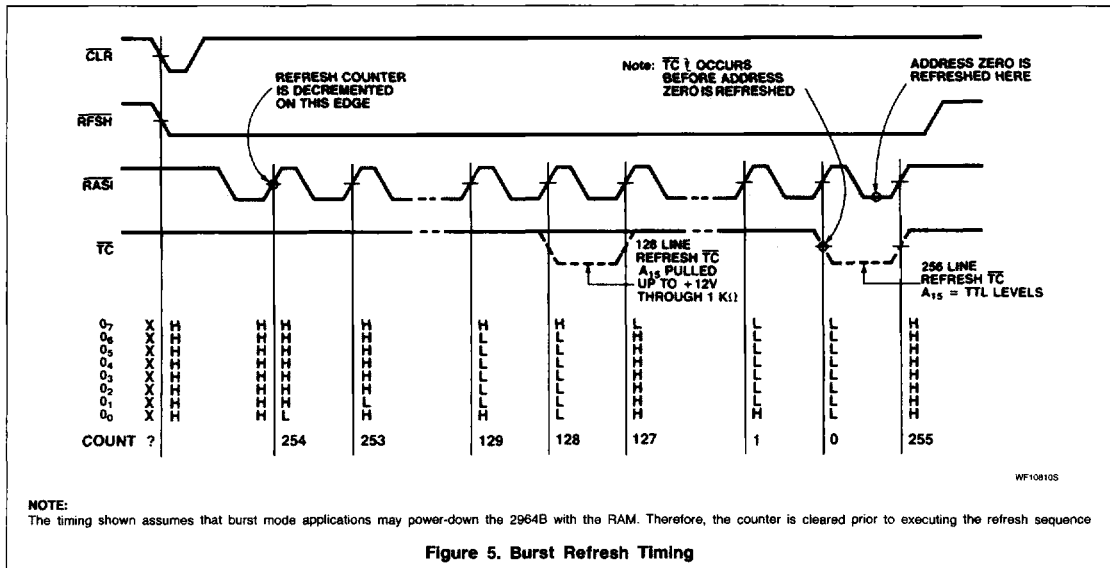
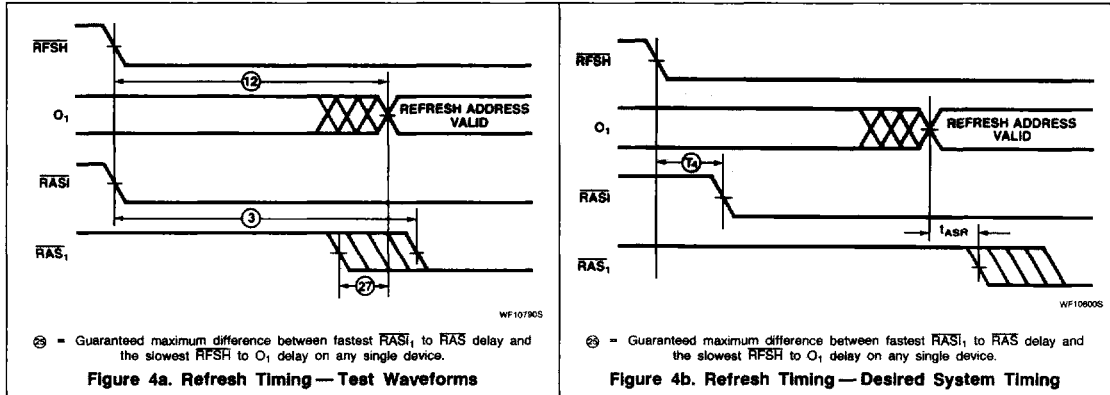

# Dynamic Memory Controller

# 2964B

## ORDERING INFORMATION

Commercial:

N2964BN (Plastic)

N2964BI (Ceramic)

## PACKAGE DATA

Type: Plastic or Ceramic

Configuration: DIP

Width: 0.6 in.

Length: 2.0 in.

Pin Centers: 0.1 in.

## APPLICATIONS

### Speed with Minimum Skew

The DMC provides Schottky speed in all of the critical paths. In addition, time skew between the Address, RAS and CAS paths is minimized (and specified) by placing these functions on the same chip. The inclusion of the CAS buffer allows matching of its propagation delay, and also provides the CAS inhibit function during RAS — only refresh.

### Input Latches

The eighteen input latches are transparent when LE is HIGH and latch the input data, meeting the set-up and hold time requirements when LE goes LOW. In systems with separate address and data buses, LE may be permanently enabled HIGH.

### Refresh Counter

The 8-bit refresh counter provides both 128 and 256 line refresh capability. Refresh con-

trol is external to allow maximum user flexibility. Transparent (hidden), burst, synchronous or asynchronous refresh modes are all possible.

The refresh counter is advanced at the LOW-to-HIGH transition of RFSH (or RASI). This assures a stable counter output for the next refresh cycle. The counter will continue to cycle through 256 addresses unless reset to zero by CLR. This actually causes all output to go HIGH since the output MUX is inverting. (Address inputs to outputs are non-inverting since both the input latches and output MUX are inverting.)

### Refresh Terminal Count

The refresh counter also provides a Terminal Count output for burst mode refresh applications. TC normally occurs at count 255 (00<sub>7</sub> to 0<sub>7</sub> all LOW when RFSH is LOW). TC can be made to occur at count 127 for 128 line burst mode refresh by pulling A<sub>15</sub> up to +12V through a 1K $\Omega$   $\pm$ 10% resistor. The counter actually cycles through 256 with TC determined by A<sub>15</sub>. Otherwise A<sub>15</sub> functions as an address input when driven at normal TTL levels.

### Three-Input 8-Bit Address Multiplexer

The address MUX is 8-bits wide (for 64K DRAMs) and has three data sources, the lower address input latch (A<sub>0</sub> to A<sub>7</sub>), the upper address input latch (A<sub>8</sub> to A<sub>15</sub>), and the internal refresh counter. The lower address latch is selected when MSEL is HIGH. This is

normally the Row address. The upper address latch is selected when MSEL is LOW. This is normally the Column address. The third source — the refresh counter is selected when RFSH is LOW and overrides MSEL.

When RFSH goes LOW, the MUX selects the refresh counter address and CASO is inhibited. Also, the RAS Decoder function is changed from one-of-four to four-of-four so all RAS outputs RAS<sub>0</sub> – RAS<sub>3</sub> go low to refresh all banks of memory when RASI goes LOW. When RFSH is HIGH, only one RAS output goes low, determined by the RAS Select inputs, RSEL<sub>0</sub> and RSEL<sub>1</sub>. In either case the RAS Decoder output timing is controlled by RASI to make sure the refresh count appears at 00<sub>0</sub> – 0<sub>7</sub> before RAS<sub>0</sub> – RAS<sub>3</sub> goes LOW. This assures meeting Row address Set-up time requirement of the DRAM (t<sub>ASR</sub>).

### Maximum Performance System

The typical organization of a maximum performance 16-bit system including Error Detection and Correction is shown in Figure 6. Delay lines provide the most accurate timing and are recommended for RAS, MSEL, and CAS timing in this type of system.

### Controlling 16K RAMS or Smaller Systems

16K DRAMs require seven address inputs and 128 line refresh. Also A<sub>0</sub> is often used to designate upper or lower byte transactions in 16-bit systems. These modifications are shown in Figure 7.

# Dynamic Memory Controller

2964B

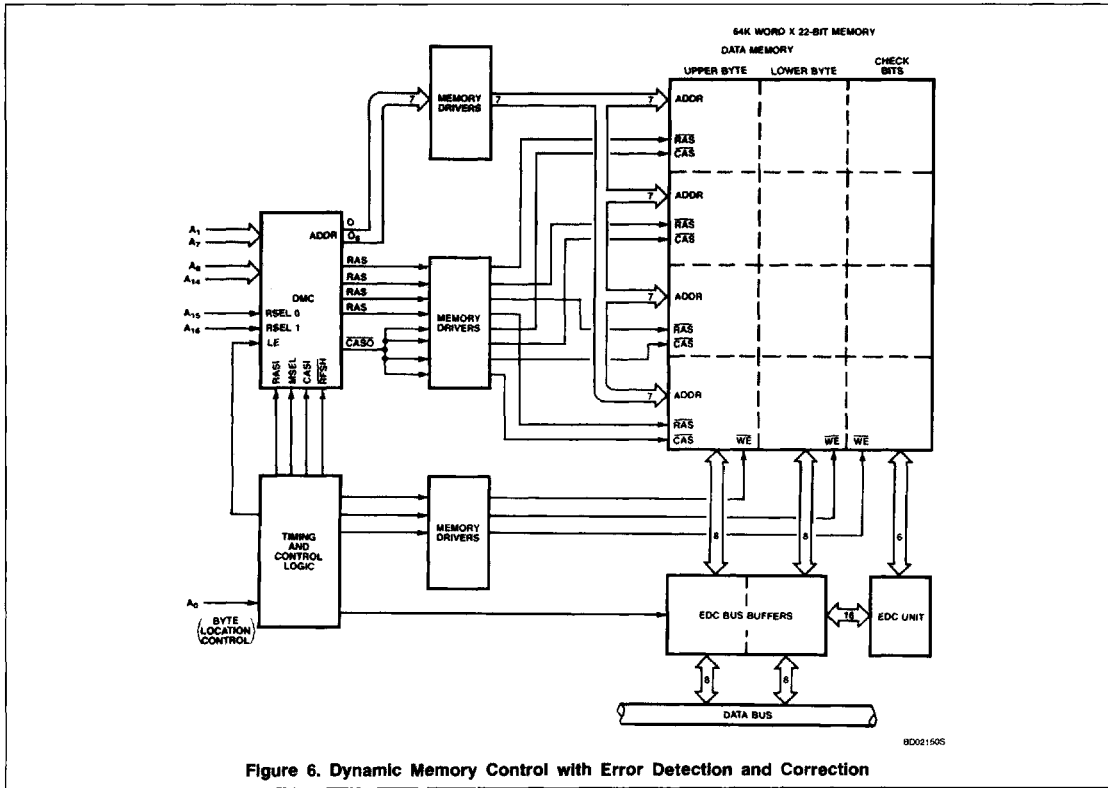

Figure 6. Dynamic Memory Control with Error Detection and Correction

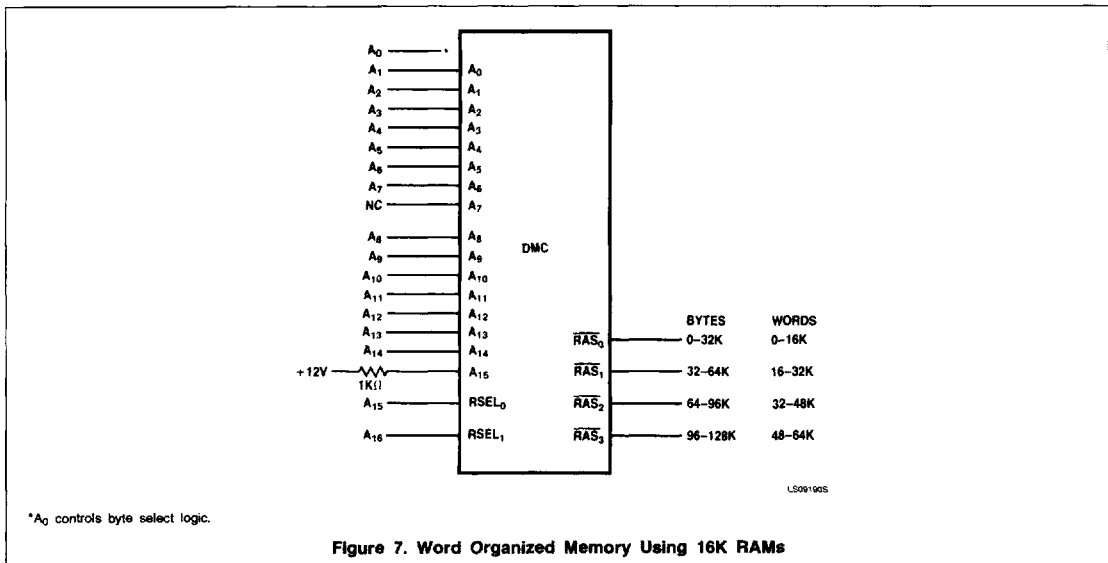

Figure 7. Word Organized Memory Using 16K RAMs