

- Independent Asynchronous Inputs and Outputs
- 16 Words by 4 Bits
- Data Rates up to 40 MHz
- Fall-Through Time 14 ns Typical
- 3-State Outputs
- Package Options Include Plastic Small-Outline Package (DW), Plastic Chip Carriers (FN), and Standard Plastic 300-mil DIPs (N)

description

This 64-bit memory features high speed and fast fall-through times. It is organized as 16 words by 4 bits.

A first-in, first-out (FIFO) memory is a storage device that allows data to be written into and read from its array at independent data rates. This FIFO is designed to process data at rates up to 40 MHz in a bit-parallel format, word by word.

Data is written into memory on a low-to-high transition at the load-clock (LDCK) input and is read out on a low-to-high transition at the unload-clock (UNCK) input. The memory is full when the number of words clocked in exceeds by 16 the number of words clocked out. When the memory is full, LDCK signals have no effect on the data residing in memory. When the memory is empty, UNCK signals have no effect.

Status of the FIFO memory is monitored by the $\overline{\text{FULL}}$ and $\overline{\text{EMPTY}}$ output flags. The $\overline{\text{FULL}}$ output is low when the memory is full and high when it is not full. The $\overline{\text{EMPTY}}$ output is low when the memory is empty and high when it is not empty.

A low level on the reset ($\overline{\text{RST}}$) input resets the internal stack-control pointers and also sets $\overline{\text{EMPTY}}$ low and sets $\overline{\text{FULL}}$ high. The Q outputs are not reset to any specific logic level. The first low-to-high transition on LDCK, after either a $\overline{\text{RST}}$ pulse or from an empty condition, causes $\overline{\text{EMPTY}}$ to go high and the data to appear on the Q outputs. It is important to note that the first word does not have to be unloaded. Data outputs are noninverting with respect to the data inputs and are at high impedance when the output-enable (OE) input is low. OE does not affect the $\overline{\text{FULL}}$ or $\overline{\text{EMPTY}}$ output flags. Cascading is easily accomplished in the word-width direction but is not possible in the word-depth direction.

The SN74ALS232B is characterized for operation from 0°C to 70°C.

DW OR N PACKAGE
(TOP VIEW)

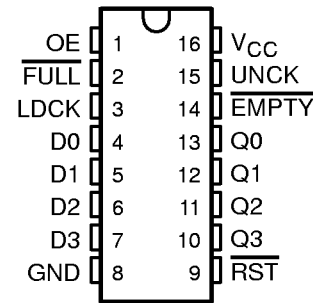

FN PACKAGE
(TOP VIEW)

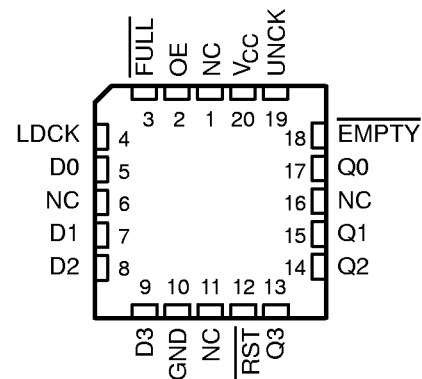

NC – No internal connection



Please be aware that an important notice concerning availability, standard warranty, and use in critical applications of Texas Instruments semiconductor products and disclaimers thereto appears at the end of this data sheet.

PRODUCTION DATA information is current as of publication date. Products conform to specifications per the terms of Texas Instruments standard warranty. Production processing does not necessarily include testing of all parameters.

**TEXAS
INSTRUMENTS**

POST OFFICE BOX 655303 • DALLAS, TEXAS 75265

Copyright © 1998, Texas Instruments Incorporated

SN74ALS232B

16 × 4 ASYNCHRONOUS FIRST-IN, FIRST-OUT MEMORY

SCAS251B – FEBRUARY 1989 – REVISED APRIL 1998

logic symbol†

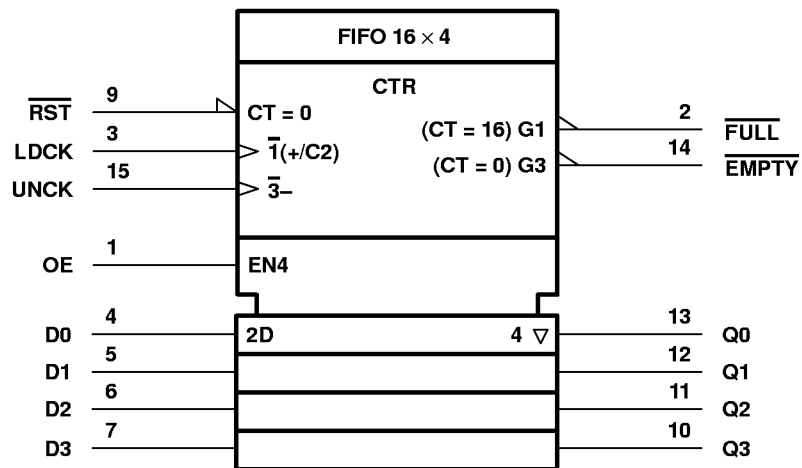

† This symbol is in accordance with ANSI/IEEE Standard 91-1984 and IEC Publication 617-12. The symbol is functionally accurate but does not show the details of implementation; for these, see the logic diagram. The symbol represents the memory as if it were controlled by a single counter whose content is the number of words stored at the time. Output data is invalid when the counter content (CT) is 0. Pin numbers shown are for the DW and N packages.

SN74ALS232B

16 × 4 ASYNCHRONOUS FIRST-IN, FIRST-OUT MEMORY

SCAS251B – FEBRUARY 1989 – REVISED APRIL 1998

logic diagram (positive logic)

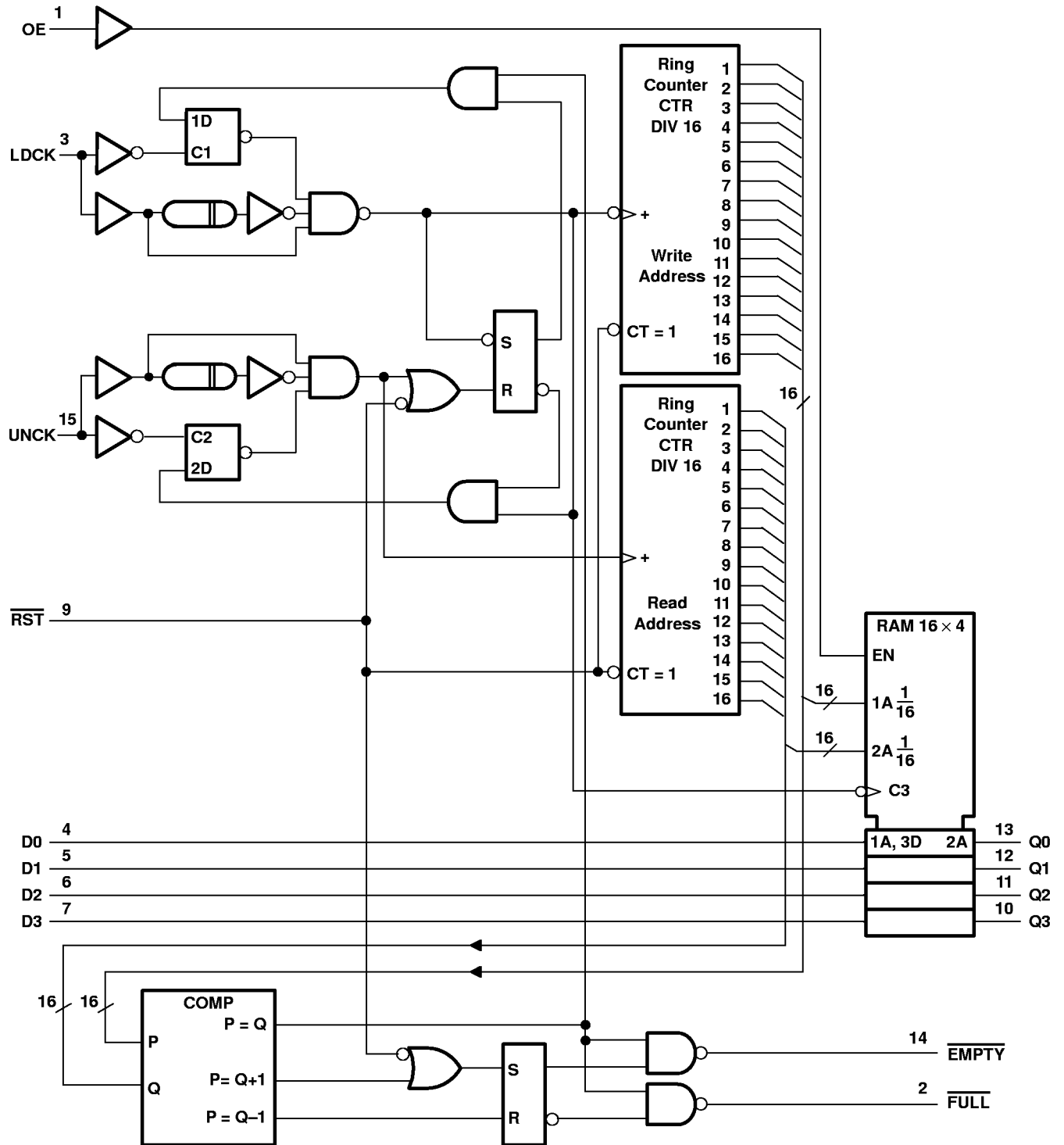

Pin numbers shown are for the DW and N packages.

SN74ALS232B

16 × 4 ASYNCHRONOUS FIRST-IN, FIRST-OUT MEMORY

SCAS251B – FEBRUARY 1989 – REVISED APRIL 1998

timing diagram

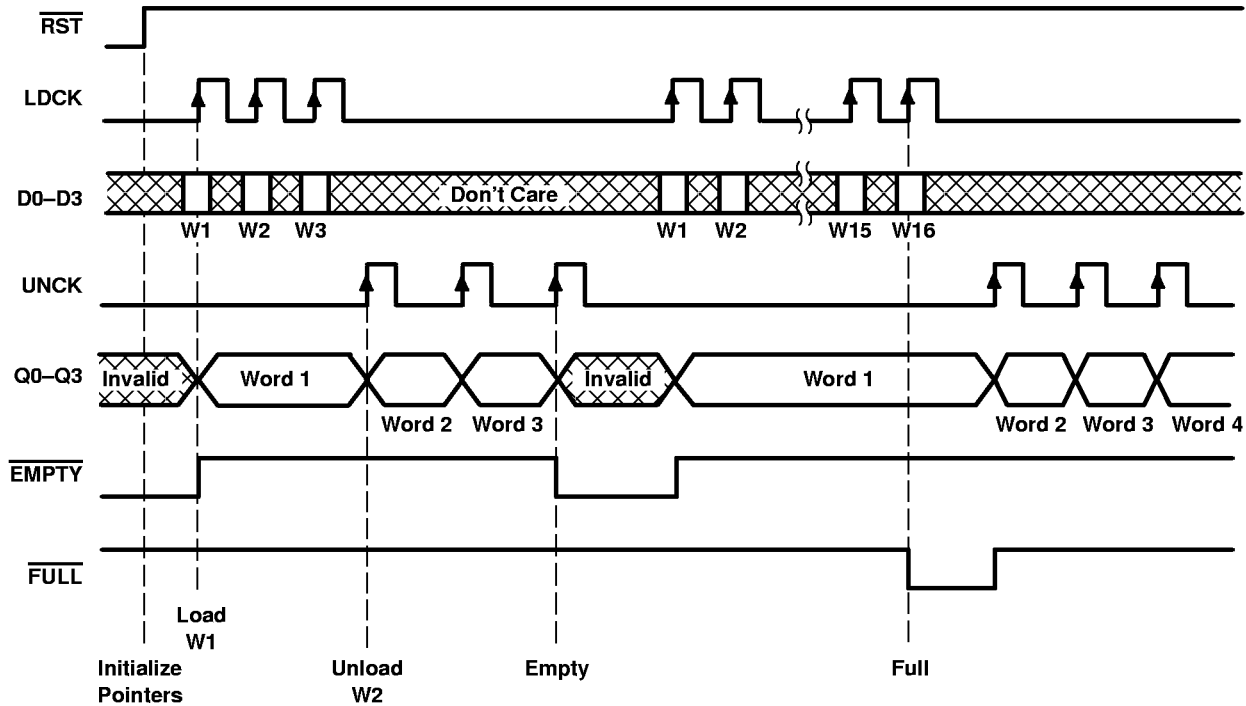

absolute maximum ratings over operating free-air temperature range (unless otherwise noted)†

Supply voltage range, V_{CC}	-0.5 V to 7 V
Input voltage range, V_I	-0.5 V to 7 V
Voltage range applied to a disabled 3-state output	-0.5 V to 5.5 V
Package thermal impedance, θ_{JA} (see Note 2): DW package	105°C/W
FN package	83°C/W
N package	78°C/W
Storage temperature range, T_{stg}	-65°C to 150°C

† Stresses beyond those listed under "absolute maximum ratings" may cause permanent damage to the device. This is a stress rating only, and functional operation of the device at these or any other conditions beyond those indicated in the "recommended operating conditions" section of this specification is not implied. Exposure to absolute-maximum-rated conditions for extended periods may affect device reliability.

NOTES: 1. All voltage values are with respect to GND.

2. The package thermal impedance is calculated in accordance with JESD 51, except for through-hole packages, which use a trace length of zero.



POST OFFICE BOX 655303 • DALLAS, TEXAS 75265

SN74ALS232B

16 × 4 ASYNCHRONOUS FIRST-IN, FIRST-OUT MEMORY

SCAS251B – FEBRUARY 1989 – REVISED APRIL 1998

recommended operating conditions (see Note 3)

		MIN	NOM	MAX	UNIT
V _{CC}	Supply voltage	4.5	5	5.5	V
V _{IH}	High-level input voltage	2			V
V _{IL}	Low-level input voltage			0.8	V
I _{OH}	High-level output current	Q outputs		-2.6	mA
		FULL, EMPTY		-0.4	
I _{OL}	Low-level output current	Q outputs		24	mA
		FULL, EMPTY		8	
T _A	Operating free-air temperature	0		70	°C

NOTE 3: To ensure proper operation of this high-speed FIFO device, it is necessary to provide a clean signal to the LDCK and UNCK clock inputs. Any excessive noise or glitching on the clock inputs that violates limits for maximum V_{IL}, minimum V_{IH}, or minimum pulse duration can cause a false clock or improper operation of the internal read and write pointers.

electrical characteristics over recommended operating free-air temperature range (unless otherwise noted)

PARAMETER		TEST CONDITIONS		MIN	TYP†	MAX	UNIT
V _{IK}		V _{CC} = 4.5 V,	I _I = -18 mA			-1.2	V
V _{OH}	Q outputs	V _{CC} = 4.5 V,	I _{OH} = -2.6 mA	2.4	3.2		V
	FULL, EMPTY	V _{CC} = 4.5 V to 5.5 V,	I _{OH} = -0.4 mA	V _{CC} -2			
V _{OL}	Q outputs	V _{CC} = 4.5 V	I _{OL} = 12 mA	0.25	0.4	V	
			I _{OL} = 24 mA	0.35	0.5		
	FULL, EMPTY	V _{CC} = 4.5 V	I _{OL} = 4 mA	0.25	0.4		
			I _{OL} = 8 mA	0.35	0.5		
I _{OZH}		V _{CC} = 5.5 V,	V _O = 2.7 V			20	μA
I _{OZL}		V _{CC} = 5.5 V,	V _O = 0.4 V			-20	μA
I _I		V _{CC} = 5.5 V,	V _I = 7 V			0.1	mA
I _{IH}		V _{CC} = 5.5 V,	V _I = 2.7 V			20	μA
I _{IL}		V _{CC} = 5.5 V,	V _I = 0.4 V			-0.2	mA
I _{O‡}		V _{CC} = 5.5 V,	V _O = 2.25 V	-30		-112	mA
I _{CC}		V _{CC} = 5.5 V			80	125	mA

† All typical values are at V_{CC} = 5 V, T_A = 25°C.

‡ The output conditions have been chosen to produce a current that closely approximates one-half of the true short-circuit output current, I_{OS}.



SN74ALS232B

16 × 4 ASYNCHRONOUS FIRST-IN, FIRST-OUT MEMORY

SCAS251B – FEBRUARY 1989 – REVISED APRIL 1998

timing requirements over recommended operating free-air temperature range (see Figure 1)

		MIN	NOM	MAX	UNIT
$f_{\text{clock}}^{\dagger}$	Clock frequency	LDCK		40	MHz
		UNCK		40	
t_w	Pulse duration	$\overline{\text{RST}}$ low	18		ns
		LDCK low	15		
		LDCK high	10		
		UNCK low	15		
		UNCK high	10		
t_{su}	Setup time	Data before LDCK \uparrow	8		ns
		LDCK inactive before $\overline{\text{RST}}\uparrow$	5		
t_h	Hold time	Data after LDCK \uparrow	5		ns
		LDCK inactive after $\overline{\text{RST}}\uparrow$	5		

\dagger The maximum possible clock frequency is 40 MHz. The maximum clock frequency when using a 50% duty cycle is 33.3 MHz.

switching characteristics (see Figure 1)

PARAMETER	FROM (INPUT)	TO (OUTPUT)	MIN	TYP \ddagger	MAX	MIN	MAX	UNIT
f_{max}	LDCK, UNCK			50		40		MHz
t_{pd}	LDCK \uparrow	Any Q	14	23	6	30	ns	
	UNCK \uparrow		15	23	6	30		
t_{PLH}	LDCK \uparrow	$\overline{\text{EMPTY}}$	13	20	5	25	ns	
t_{PHL}	UNCK \uparrow	$\overline{\text{EMPTY}}$	15	22	6	27	ns	
	$\overline{\text{RST}}\downarrow$		15	21	5	26		
	LDCK \uparrow	FULL	15	22	6	27		
t_{PLH}	UNCK \uparrow	$\overline{\text{FULL}}$	13	20	5	25	ns	
	$\overline{\text{RST}}\downarrow$		16	23	7	28		
t_{en}	OE \uparrow	Q	5	12	1	14	ns	
t_{dis}	OE \downarrow	Q	5	12	1	16	ns	

\ddagger Typical values at $V_{\text{CC}} = 5\text{ V}$, $T_A = 25^\circ\text{C}$.



PARAMETER MEASUREMENT INFORMATION

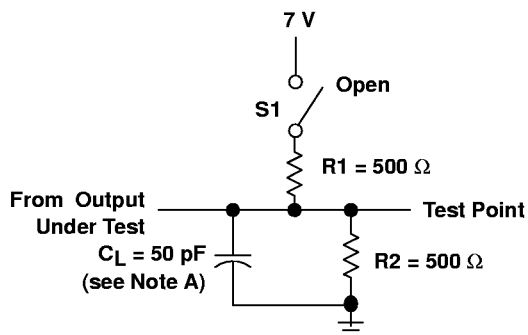

LOAD CIRCUIT FOR 3-STATE OUTPUTS

SWITCH POSITION TABLE

PARAMETER	S1
t_{en}	t_{pZH} Open
	t_{pZL} Closed
t_{dis}	t_{pHZ} Open
	t_{pLZ} Closed
t_{pd}	t_{pLH} Open
	t_{pHL} Open

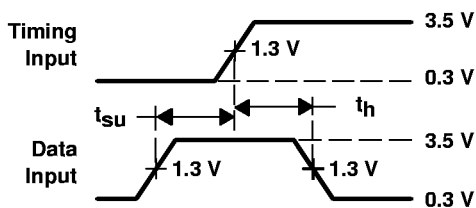

VOLTAGE WAVEFORMS
SETUP AND HOLD TIMES

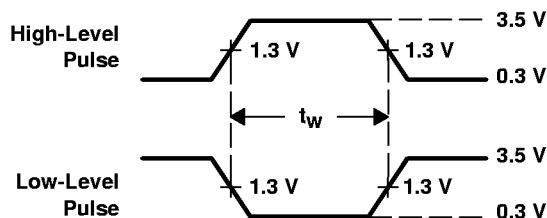

VOLTAGE WAVEFORMS
PULSE DURATION

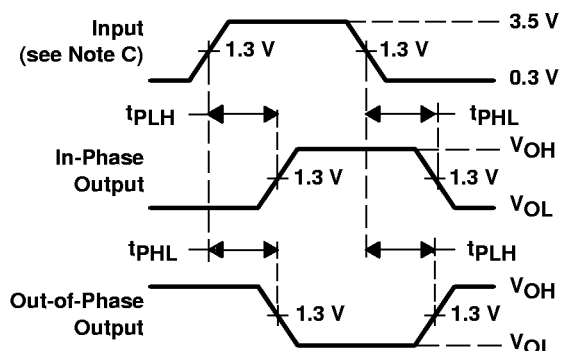

VOLTAGE WAVEFORMS
PROPAGATION DELAY TIMES

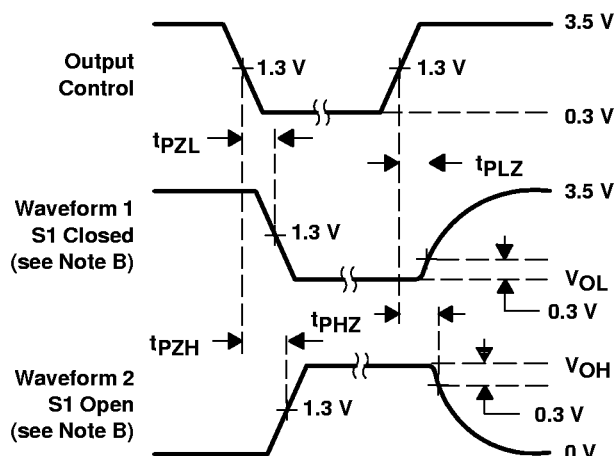

VOLTAGE WAVEFORMS
ENABLE AND DISABLE TIMES, 3-STATE OUTPUTS

- NOTES: A. C_L includes probe and jig capacitance.
 B. Waveform 1 is for an output with internal conditions such that the output is low except when disabled by the output control. Waveform 2 is for an output with internal conditions such that the output is high except when disabled by the output control.
 C. All input pulses are supplied by generators having the following characteristics: $PRR \leq 1$ MHz, $Z_O = 50 \Omega$, $t_r \leq 2$ ns, $t_f \leq 2$ ns.
 D. The outputs are measured one at a time with one transition per measurement.

Figure 1. Load Circuit and Voltage Waveforms

IMPORTANT NOTICE

Texas Instruments and its subsidiaries (TI) reserve the right to make changes to their products or to discontinue any product or service without notice, and advise customers to obtain the latest version of relevant information to verify, before placing orders, that information being relied on is current and complete. All products are sold subject to the terms and conditions of sale supplied at the time of order acknowledgement, including those pertaining to warranty, patent infringement, and limitation of liability.

TI warrants performance of its semiconductor products to the specifications applicable at the time of sale in accordance with TI's standard warranty. Testing and other quality control techniques are utilized to the extent TI deems necessary to support this warranty. Specific testing of all parameters of each device is not necessarily performed, except those mandated by government requirements.

CERTAIN APPLICATIONS USING SEMICONDUCTOR PRODUCTS MAY INVOLVE POTENTIAL RISKS OF DEATH, PERSONAL INJURY, OR SEVERE PROPERTY OR ENVIRONMENTAL DAMAGE ("CRITICAL APPLICATIONS"). TI SEMICONDUCTOR PRODUCTS ARE NOT DESIGNED, AUTHORIZED, OR WARRANTED TO BE SUITABLE FOR USE IN LIFE-SUPPORT DEVICES OR SYSTEMS OR OTHER CRITICAL APPLICATIONS. INCLUSION OF TI PRODUCTS IN SUCH APPLICATIONS IS UNDERSTOOD TO BE FULLY AT THE CUSTOMER'S RISK.

In order to minimize risks associated with the customer's applications, adequate design and operating safeguards must be provided by the customer to minimize inherent or procedural hazards.

TI assumes no liability for applications assistance or customer product design. TI does not warrant or represent that any license, either express or implied, is granted under any patent right, copyright, mask work right, or other intellectual property right of TI covering or relating to any combination, machine, or process in which such semiconductor products or services might be or are used. TI's publication of information regarding any third party's products or services does not constitute TI's approval, warranty or endorsement thereof.