

MV500

REMOTE CONTROL TRANSMITTER

Together with a simple low cost keypad, an infra-red diode and a transistor, the MV500 forms a complete transmitter for remote control data. The device uses pulse position modulation (PPM) without a carrier and is therefore best suited to infra-red or direct wire link applications. CMOS technology is used which allows low power battery operation down to 3V. One of three output data rates may be selected, all timing being derived from a low cost ceramic resonator. The MV500 may be used with the MV601 remote control receiver or decoded directly by a microprocessor.

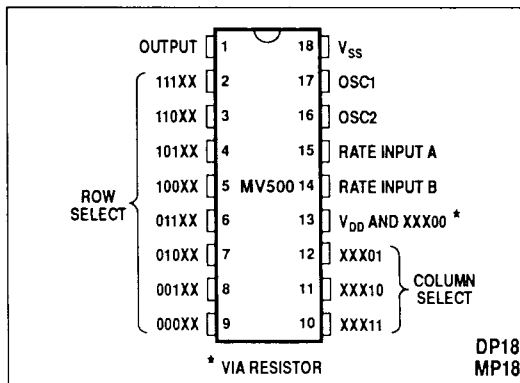

Fig.1 Pin connections - top view

FEATURES

- Very Low Power Requirements
- 3V to 9V Operation
- Low Cost Ceramic Resonator
- Selectable Data Rates
- Single Pole Key Matrix
- Few External Components
- Code Synchronising Pulses

ABSOLUTE MAXIMUM RATINGS

Supply voltage	-0.5V to 11V
Input voltage (all pins)	-0.5V to V_{DD} +0.5V
Operating temperature range	0°C to +70°C
Storage temperature range	-55°C to +125°C

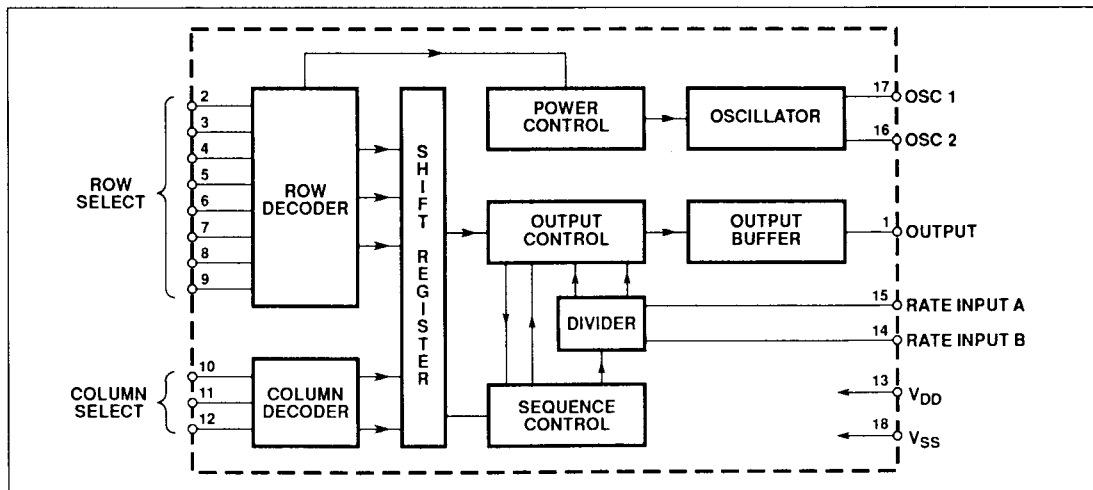

Fig.2 MV500 block diagram

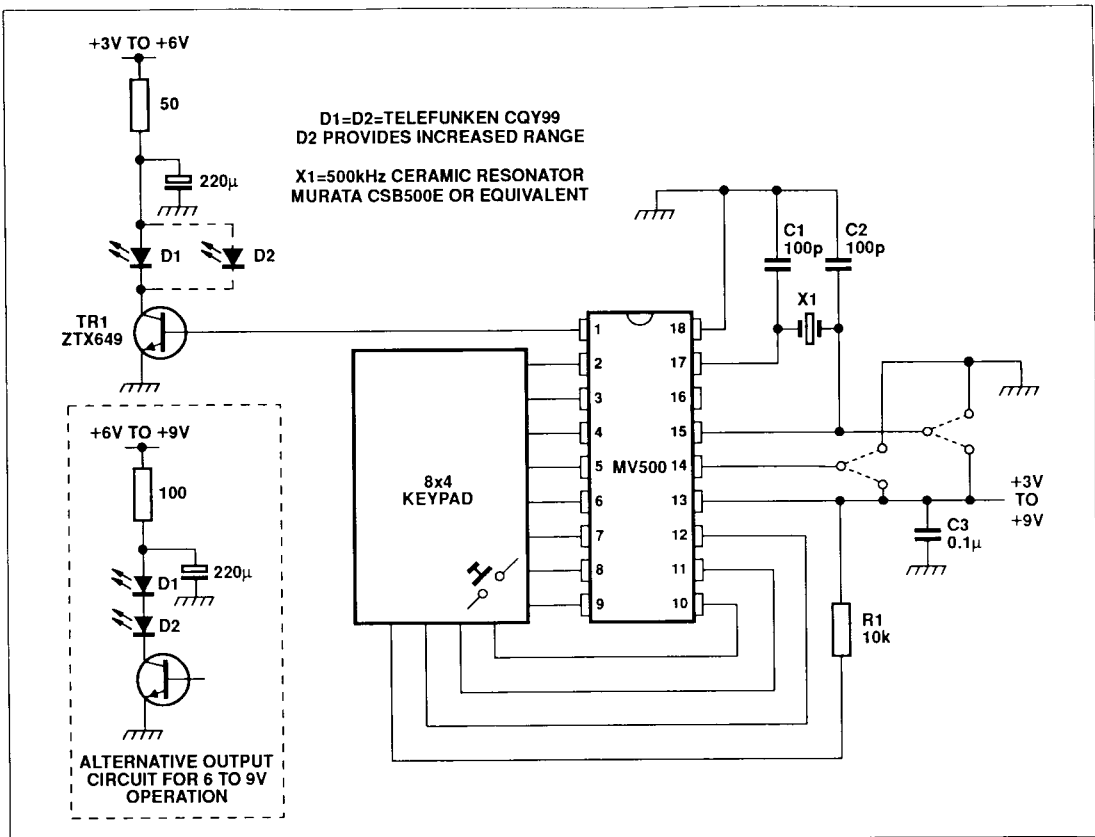

Fig.4 Infra-red application circuit

OPERATION

The circuit diagram of Fig. 4 shows a typical infra-red transmitter application. With no key pressed, the MV500 remains in its power-down mode, isolating the oscillator and most of the logic from the supply, thus minimising the drain on the battery. The output is held low.

The device may be activated in one of two ways:-

(a) one or both of the RATE inputs is held high, then a key switch is closed connecting any COLUMN to any ROW, or

(b) any COLUMN and ROW are connected, then one or both of the RATE inputs is taken high.

Once activated, power is applied to the rest of the device, the oscillator started and a delay imposed before any change at the output occurs. After this time, an initial sync pulse is transmitted, followed by the code word, which is repeated for as long as the key remains pressed. When the key is released, the word being transmitted is completed before the device enters its standby mode again.

Taking both RATE inputs low will also force the device into its power down state at the end of the current word. A final sync pulse is always added at the end of the last word to be transmitted (Fig. 3).

When the transmitter is operated from a supply between 6V and 9V, two infra-red LEDs may be used in series as shown inset in Fig. 4. At other voltages, consideration must be given to the arrangement of diodes used and a series resistance should be used to limit the diode current. It should be noted that using two diodes in parallel increases the current drawn from the battery at each pulse. A significant increase in range may be obtained by using a plated plastic parabolic reflector in conjunction with one or two diodes, rather than simply increasing the number or power of the diodes used.

Transistor TR1 should be chosen to have high current gain and fast switching speeds at the current levels relevant to the diode arrangement used.