

< High-power GaAs FET (small signal gain stage) >

MGF0952P

L & S BAND / 2W

SMD / Plastic Mold non - matched

DESCRIPTION

The MGF0952P GaAs FET with an N-channel schottky Gate, is designed for use L/S band amplifiers.

FEATURES

- High output power
Po=36.5dBm(TYP.) @f=2.15GHz,Pin=25dBm
- High power gain
GLP=13.0dB(TYP.) @f=2.15GHz
- High power added efficiency
ηadd=40%(TYP.) @f=2.15GHz,Pin=25dBm
- Plastic Mold Lead-less Package

APPLICATION

- For L/S Band power amplifiers

QUALITY

- GG

RECOMMENDED BIAS CONDITIONS

- Vds=10V
- Ids=700mA
- Rg=500Ω

Delivery Tape & Reel(1K)

Absolute maximum ratings (Ta=25°C)

Symbol	Parameter	Ratings	Unit
VGDO	Gate to Drain Voltage	-15	V
VGSO	Gate to source voltage	-15	V
ID	Drain current	3500	mA
IGR	Reverse gate current	-10	mA
IGF	Forward gate current	21	mA
PT*1	Total power dissipation	19.2	W
Tch	Channel temperature	150	°C
Tstg	Storage temperature	-40 to +150	°C

*1:Tc=25°C

Electrical characteristics (Ta=25°C)

Symbol	Parameter	Test conditions	Limits			Unit
			Min.	Typ.	Max.	
VGS(off)	Gate to source cut-off voltage	VDS=3V, ID=12.6mA	-1	-	-5	V
Po	Output power	VDS=10V, ID=700mA, f=2.15GHz	35.5	36.5	-	dBm
ηadd	Power added Efficiency					
GLP	Linear Power Gain	VDS=10V, ID=700mA, Pi=18dBm	11	13.0	-	dB
Rth(ch-c)	Thermal Resistance *1	ΔVf Method	-	4.5	6.5	°C/W

*1:Channel to case / Above parameters, ratings, limits are subject to change.

MGF0952P

L & S BAND / 4.5W

SMD / Plastic Mold non - matched

MGF0952P TYPICAL CHARACTERISTICS

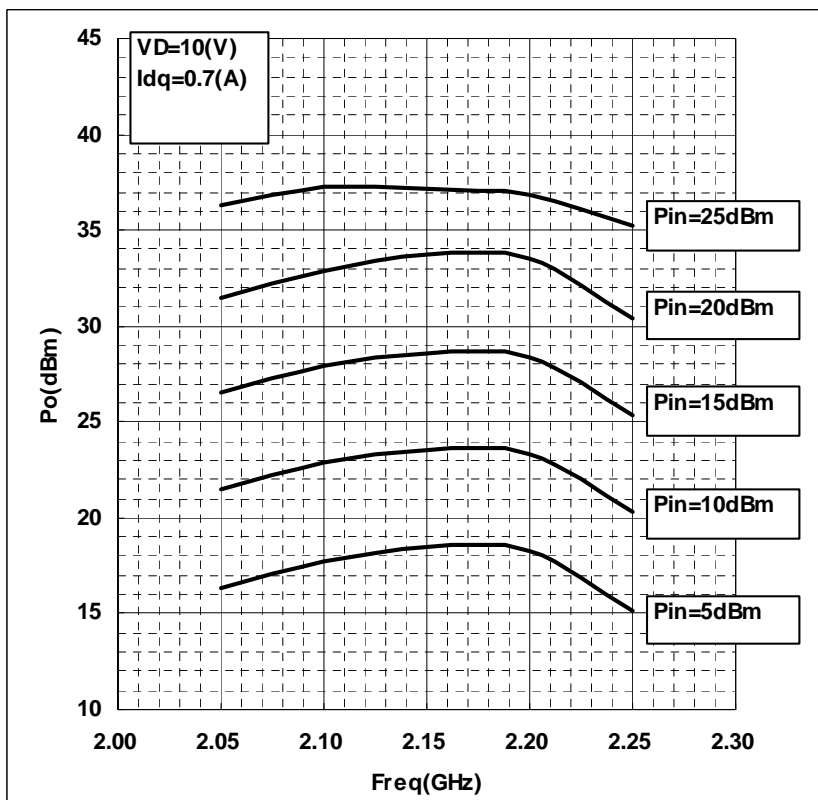
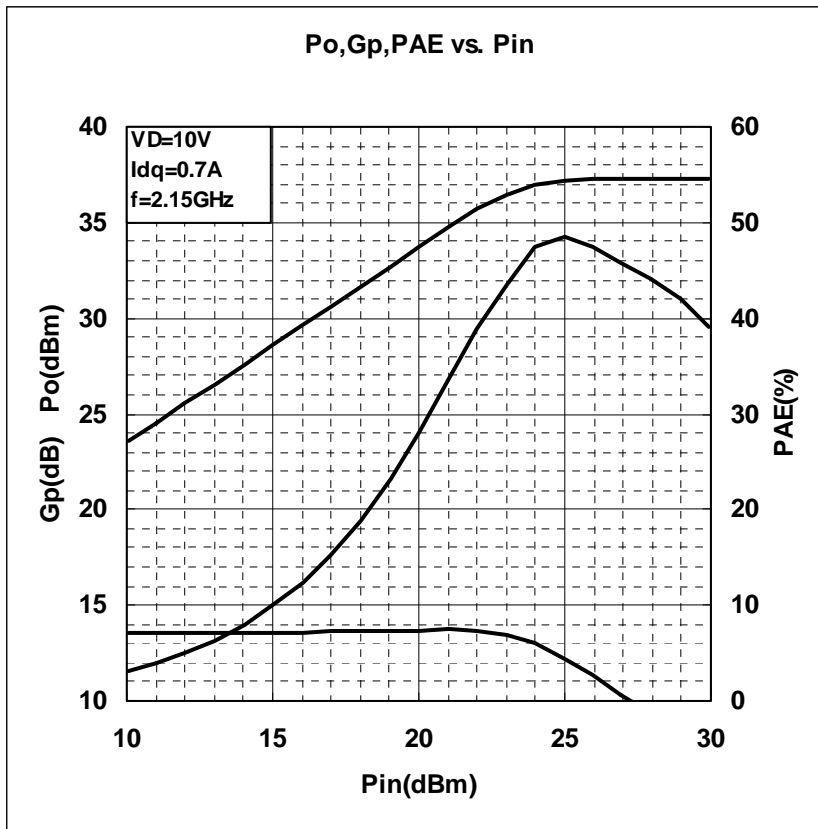

< High-power GaAs FET (small signal gain stage) >

MGF0952P

L & S BAND / 4.5W

SMD / Plastic Mold non - matched

MGF0952P TYPICAL CHARACTERISTICS

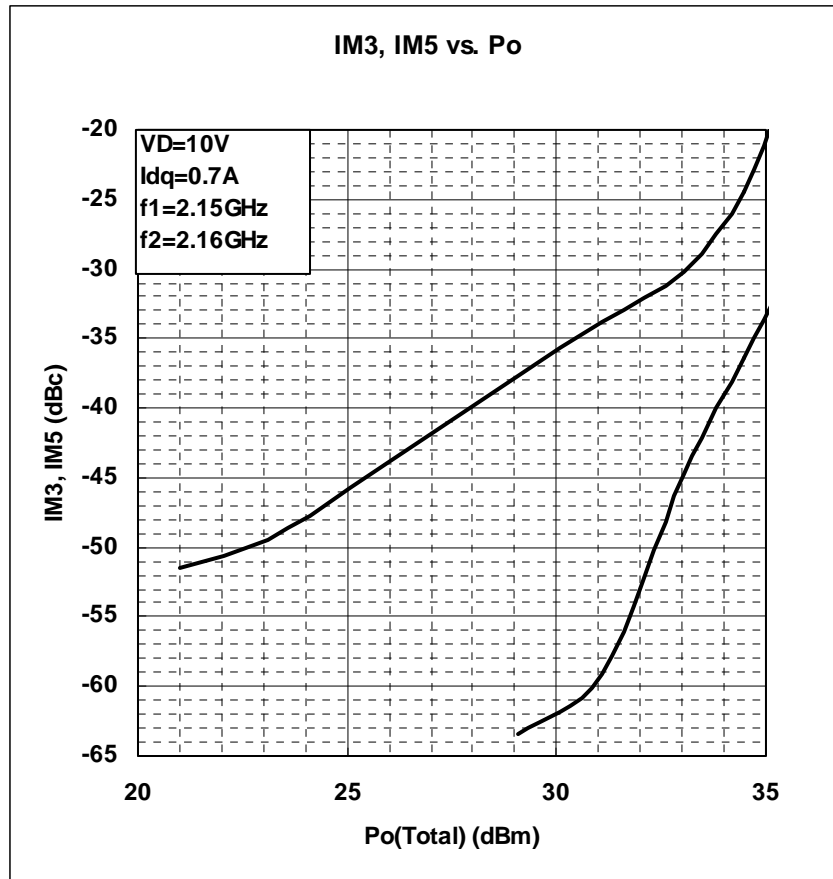

< High-power GaAs FET (small signal gain stage) >

MGF0952P

L & S BAND / 4.5W

SMD / Plastic Mold non - matched

MGF0952P S PARAMETERS (Ta=25°C,VD=10V,ID=700mA, Reference Plane see Fig.1)

!freq.	S11		S21		S12		S22	
	(mag)	(ang)	(mag)	(ang)	(mag)	(ang)	(mag)	(ang)
0.60	0.941	-155.46	3.198	95.74	0.020	14.53	0.775	-176.77
0.80	0.945	-161.45	2.434	90.37	0.020	12.33	0.777	-176.95
1.00	0.945	-165.05	1.970	86.23	0.021	12.00	0.777	-176.88
1.20	0.946	-167.53	1.656	82.72	0.021	10.97	0.776	-176.62
1.40	0.948	-169.74	1.383	79.43	0.020	11.07	0.784	-176.51
1.60	0.949	-170.98	1.223	76.56	0.020	11.75	0.783	-176.15
1.80	0.945	-172.20	1.097	73.77	0.020	9.96	0.782	-175.84
2.00	0.943	-173.14	0.998	71.28	0.020	10.52	0.783	-175.41
2.20	0.944	-173.68	0.918	68.77	0.020	11.92	0.782	-174.89
2.40	0.946	-174.29	0.855	66.48	0.020	12.32	0.782	-174.38
2.60	0.946	-174.91	0.802	64.21	0.020	11.26	0.781	-173.87
2.80	0.945	-175.53	0.755	61.97	0.020	10.49	0.781	-173.41
3.00	0.945	-176.04	0.717	59.85	0.021	10.21	0.780	-172.87
3.20	0.942	-176.30	0.681	57.82	0.021	8.73	0.780	-172.57
3.40	0.950	-176.75	0.658	55.70	0.020	5.23	0.785	-172.11
3.60	0.945	-178.34	0.624	53.05	0.018	4.47	0.783	-172.82
3.80	0.942	-178.98	0.600	51.01	0.018	12.59	0.778	-172.69
4.00	0.940	-179.40	0.581	48.78	0.019	16.08	0.776	-172.55
4.20	0.942	179.63	0.562	46.21	0.020	13.00	0.776	-173.07
4.40	0.942	178.51	0.543	43.59	0.021	12.22	0.778	-173.71
4.60	0.941	177.39	0.525	40.94	0.020	9.78	0.779	-174.47
4.80	0.941	176.53	0.511	38.30	0.021	8.54	0.779	-175.57
5.00	0.940	175.20	0.495	35.58	0.022	6.78	0.780	-176.58
5.20	0.939	173.69	0.481	32.70	0.021	4.96	0.783	-177.54
5.40	0.938	172.28	0.467	30.04	0.021	3.17	0	-178.54
5.60	0.936	171.29	0.457	27.42	0.022	1.75	0.786	-179.32
5.80	0.936	169.82	0.449	24.82	0.022	0.51	0.790	179.87
6.00	0.933	167.83	0.440	21.94	0.023	-0.94	0.792	178.97
6.20	0.932	166.34	0.430	19.46	0.023	-1.38	0.794	178.44
6.40	0.933	165.13	0.424	17.22	0.023	-2.56	0.797	178.03
6.60	0.931	163.73	0.421	14.95	0.024	-2.05	0.801	177.89
6.80	0.930	162.01	0.420	12.61	0.024	-3.27	0.804	177.64
7.00	0.931	160.33	0.418	10.17	0.025	-2.88	0.807	177.45

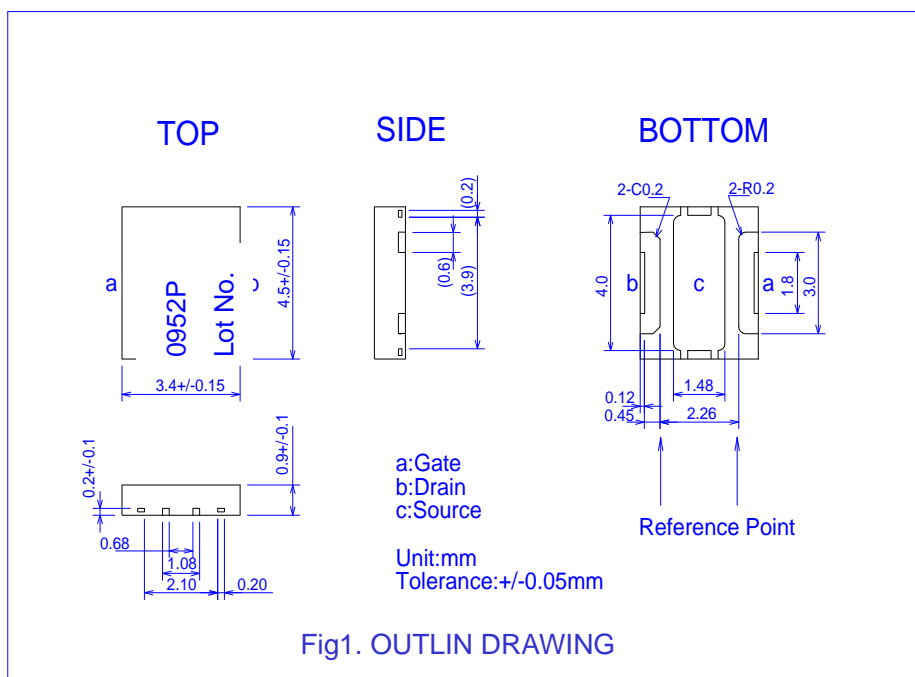

< High-power GaAs FET (small signal gain stage) >

MGF0952P

L & S BAND / 4.5W

SMD / Plastic Mold non - matched

MGF0952P TESTFIXTURE FREQ=2.15GHz

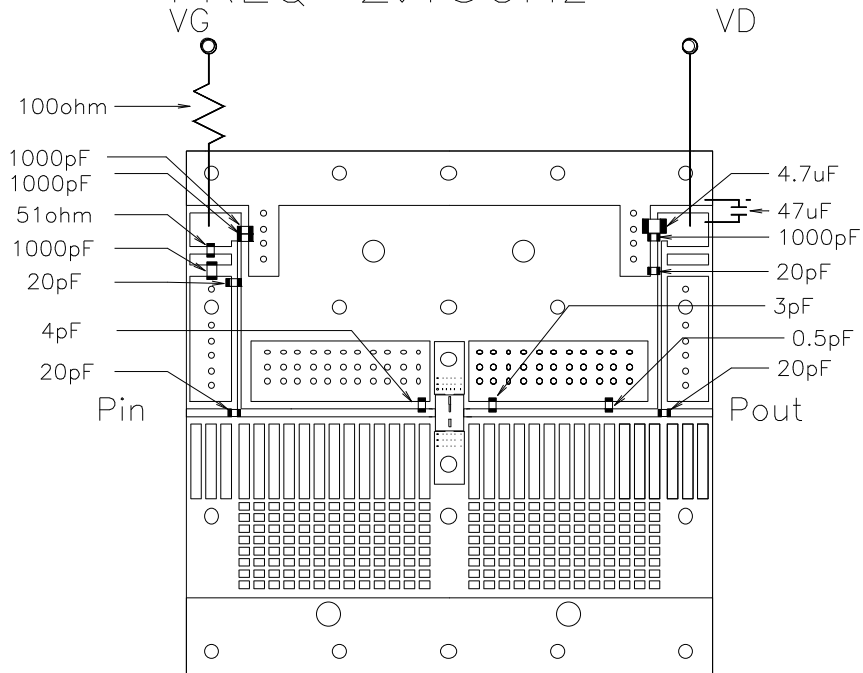

Board Material: Teflon-Fiberglass, $t=0.4\text{mm}$, $\epsilon_r=2.6$

Keep safety first in your circuit designs!

Mitsubishi Electric Corporation puts the maximum effort into making semiconductor products better and more reliable, but there is always the possibility that trouble may occur with them. Trouble with semiconductors may lead to personal injury, fire or property damage. Remember to give due consideration to safety when making your circuit designs, with appropriate measures such as (i) placement of substitutive, auxiliary circuits, (ii) use of non-flammable material or (iii) prevention against any malfunction or mishap.

Notes regarding these materials

- These materials are intended as a reference to assist our customers in the selection of the Mitsubishi semiconductor product best suited to the customer's application; they do not convey any license under any intellectual property rights, or any other rights, belonging to Mitsubishi Electric Corporation or a third party.
- Mitsubishi Electric Corporation assumes no responsibility for any damage, or infringement of any third-party's rights, originating in the use of any product data, diagrams, charts, programs, algorithms, or circuit application examples contained in these materials.
- All information contained in these materials, including product data, diagrams, charts, programs and algorithms represents information on products at the time of publication of these materials, and are subject to change by Mitsubishi Electric Corporation without notice due to product improvements or other reasons. It is therefore recommended that customers contact Mitsubishi Electric Corporation or an authorized Mitsubishi Semiconductor product distributor for the latest product information before purchasing a product listed herein.
The information described here may contain technical inaccuracies or typographical errors. Mitsubishi Electric Corporation assumes no responsibility for any damage, liability, or other loss rising from these inaccuracies or errors.
Please also pay attention to information published by Mitsubishi Electric Corporation by various means, including the Mitsubishi Semiconductor home page (<http://www.MitsubishiElectric.com/>).
- When using any or all of the information contained in these materials, including product data, diagrams, charts, programs, and algorithms, please be sure to evaluate all information as a total system before making a final decision on the applicability of the information and products. Mitsubishi Electric Corporation assumes no responsibility for any damage, liability or other loss resulting from the information contained herein.
- Mitsubishi Electric Corporation semiconductors are not designed or manufactured for use in a device or system that is used under circumstances in which human life is potentially at stake. Please contact Mitsubishi Electric Corporation or an authorized Mitsubishi Semiconductor product distributor when considering the use of a product contained herein for any specific purposes, such as apparatus or systems for transportation, vehicular, medical, aerospace, nuclear, or undersea repeater use.
- The prior written approval of Mitsubishi Electric Corporation is necessary to reprint or reproduce in whole or in part these materials.
- If these products or technologies are subject to the Japanese export control restrictions, they must be exported under a license from the Japanese government and cannot be imported into a country other than the approved destination.
Any diversion or re-export contrary to the export control laws and regulations of Japan and/or the country of destination is prohibited.
- Please contact Mitsubishi Electric Corporation or an authorized Mitsubishi Semiconductor product distributor for further details on these materials or the products contained therein.