

MC33039

Closed Loop Brushless Motor Adapter

The MC33039 is a high performance closed-loop speed control adapter specifically designed for use in brushless DC motor control systems. Implementation will allow precise speed regulation without the need for a magnetic or optical tachometer. This device contains three input buffers each with hysteresis for noise immunity, three digital edge detectors, a programmable monostable, and an internal shunt regulator. Also included is an inverter output for use in systems that require conversion of sensor phasing. Although this device is primarily intended for use with the MC33035 brushless motor controller, it can be used cost effectively in many other closed-loop speed control applications.

- Digital Detection of Each Input Transition for Improved Low Speed Motor Operation
- TTL Compatible Inputs With Hysteresis
- Operation Down to 5.5 V for Direct Powering from MC33035 Reference
- Internal Shunt Regulator Allows Operation from a Non-Regulated Voltage Source
- Inverter Output for Easy Conversion between 60°/300° and 120°/240° Sensor Phasing Conventions

CLOSED LOOP BRUSHLESS MOTOR ADAPTER

SEMICONDUCTOR TECHNICAL DATA

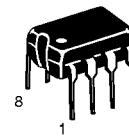

P SUFFIX
PLASTIC PACKAGE
CASE 626



D SUFFIX
PLASTIC PACKAGE
CASE 751
(SO-8)

Representative Block Diagram

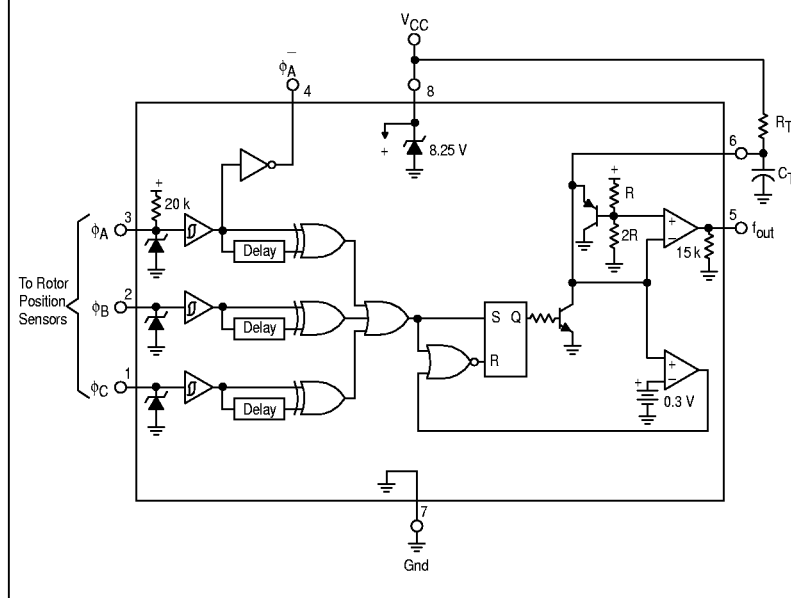

PIN CONNECTIONS

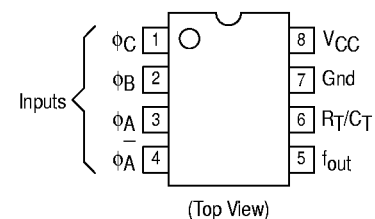

ORDERING INFORMATION

Device	Operating Temperature Range	Package
MC33039D	$T_A = -40^\circ \text{ to } +85^\circ \text{C}$	SO-8
MC33039P		Plastic DIP

MC33039

MAXIMUM RATINGS

Rating	Symbol	Value	Unit
V_{CC} Zener Current	$I_{Z(V_{CC})}$	30	mA
Logic Input Current (Pins 1, 2, 3)	I_{IH}	5.0	mA
Output Current (Pins 4, 5), Sink or Source	I_{DRV}	20	mA
Power Dissipation and Thermal Characteristics Maximum Power Dissipation @ $T_A = +85^\circ\text{C}$ Thermal Resistance, Junction-to-Air	P_D $R_{\theta JA}$	650 100	mW $^\circ\text{C}/\text{W}$
Operating Junction Temperature	T_J	+ 150	$^\circ\text{C}$
Operating Ambient Temperature Range	T_A	- 40 to + 85	$^\circ\text{C}$
Storage Temperature Range	T_{stg}	- 65 to + 150	$^\circ\text{C}$

ELECTRICAL CHARACTERISTICS ($V_{CC} = 6.25\text{ V}$, $R_T = 10\text{ k}$, $C_T = 22\text{ nF}$, $T_A = 25^\circ\text{C}$, unless otherwise noted)

Characteristic	Symbol	Min	Typ	Max	Unit
----------------	--------	-----	-----	-----	------

LOGIC INPUTS

Input Threshold Voltage					V
High State	V_{IH}	2.4	2.1	—	
Low State	V_{IL}	—	1.4	1.0	
Hysteresis	V_H	0.4	0.7	0.9	
Input Current					μA
High State ($V_{IH} = 5.0\text{ V}$)	I_{IH}				
ϕ_A		- 40	- 60	- 80	
ϕ_B, ϕ_C		—	- 0.3	- 5.0	
Low State ($V_{IL} = 0\text{ V}$)	I_{IL}				
ϕ_A		- 190	- 300	- 380	
ϕ_B, ϕ_C		—	- 0.3	- 5.0	

MONOSTABLE AND OUTPUT SECTIONS

Output Voltage					V
High State	V_{OH}				
f_{out} ($I_{source} = 5.0\text{ mA}$)		3.60	3.95	4.20	
ϕ_A ($I_{source} = 2.0\text{ mA}$)		4.20	4.75	—	
Low State	V_{OL}				
f_{out} ($I_{sink} = 10\text{ mA}$)		—	0.25	0.50	
ϕ_A ($I_{sink} = 10\text{ mA}$)		—	0.25	0.50	
Capacitor C_T Discharge Current	I_{dischg}	20	35	60	mA
Output Pulse Width (Pin 5)	t_{PW}	205	225	245	μs

POWER SUPPLY SECTION

Power Supply Operating Voltage Range ($T_A = -40^\circ$ to $+85^\circ\text{C}$)	V_{CC}	5.5	—	V_Z	V
Power Supply Current	I_{CC}	1.8	3.9	5.0	mA
Zener Voltage ($I_Z = 10\text{ mA}$)	V_Z	7.5	8.25	9.0	V
Zener Dynamic Impedance ($\Delta I_Z = 10\text{ mA}$ to 20 mA , $f \leq 1.0\text{ kHz}$)	$ Z_{ka} $	—	2.0	5.0	Ω

Figure 1. Typical Three Phase, Six Step Motor Application

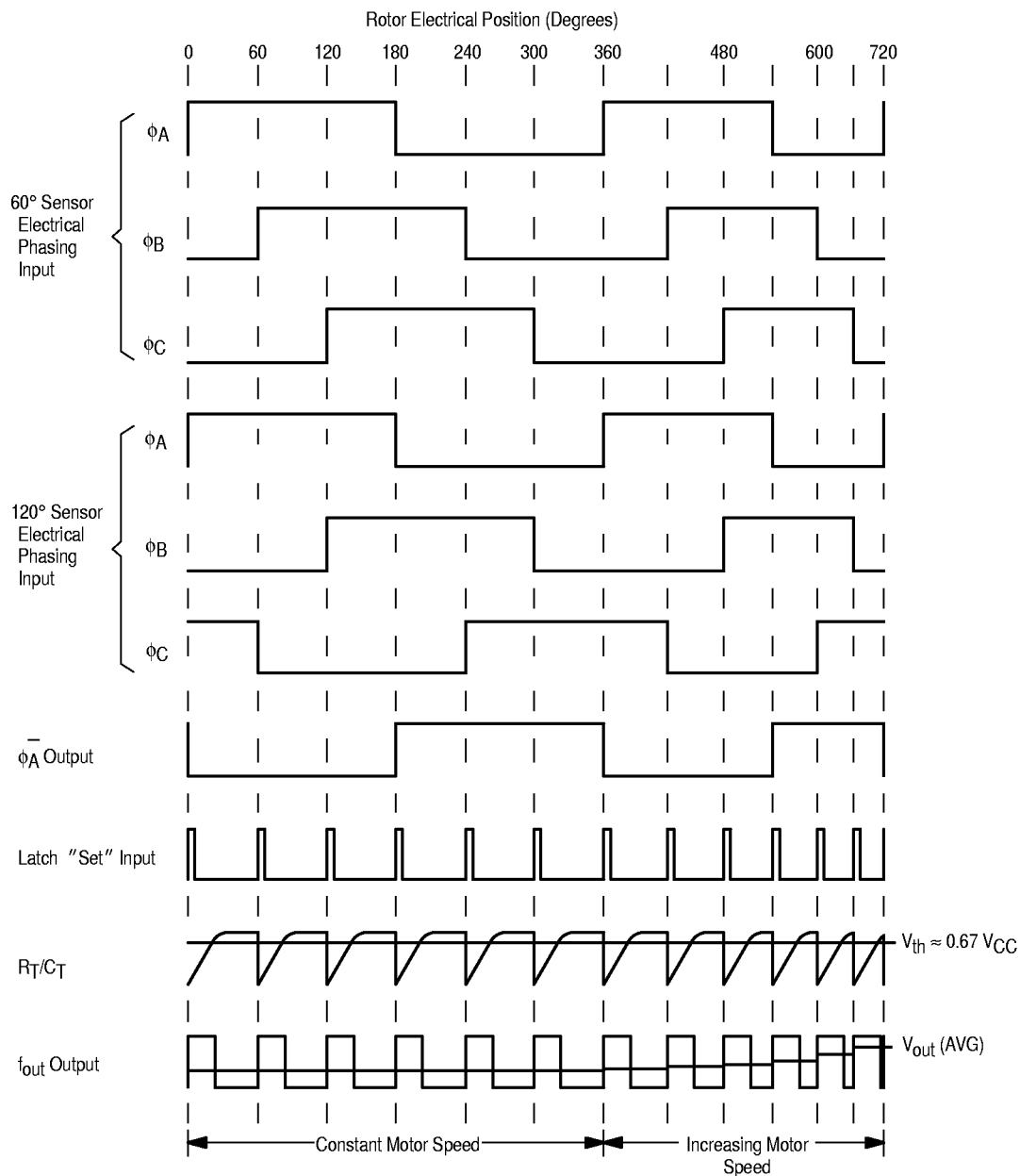

OPERATING DESCRIPTION

The MC33039 provides an economical method of implementing closed-loop speed control of brushless DC motors by eliminating the need for a magnetic or optical tachometer. Shown in the timing diagram of Figure 1, the three inputs (Pins 1, 2, 3) monitor the brushless motor rotor position sensors. Each sensor signal transition is digitally detected, OR'ed at the Latch 'Set' Input, and causes C_T to discharge. A corresponding output pulse is generated at f_{out} (Pin 5) of a defined amplitude, and programmable width determined by the values selected for R_T and C_T (Pin 6). The average voltage of the output pulse train increases with motor speed. When fed through a low pass filter or integrator, a DC voltage proportional to speed is generated. Figure 2 shows the proper connections for a typical closed loop

application using the MC33035 brushless motor controller. Constant speed operation down to 100 RPM is possible with economical three phase four pole motors.

The ϕ_A inverter output (Pin 4) is used in systems where the controller and motor sensor phasing conventions are not compatible. A method of converting from either convention to the other is shown in Figure 3. For a more detailed explanation of this subject, refer to the text above Figure 39 on the MC33035 data sheet.

The output pulse amplitude V_{OH} is constant with temperature and controlled by the supply voltage on V_{CC} (Pin 8). Operation down to 5.5 V is guaranteed over temperature. For systems without a regulated power supply, an internal 8.25 V shunt regulator is provided.

MC33039

Figure 2. Typical Closed Loop Speed Control Application

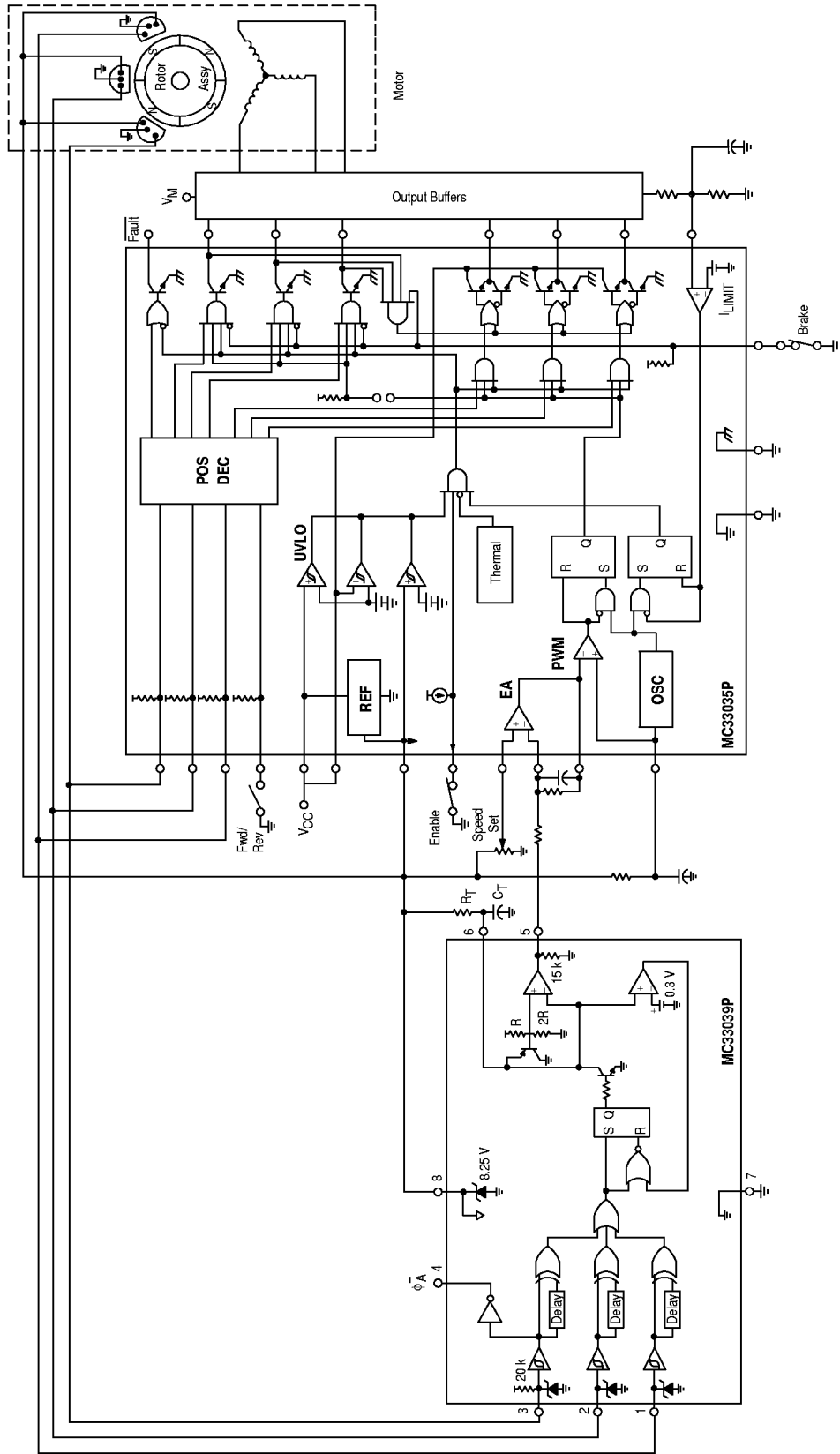

Figure 3. f_{out} , Pulse Width versus Timing Resistor

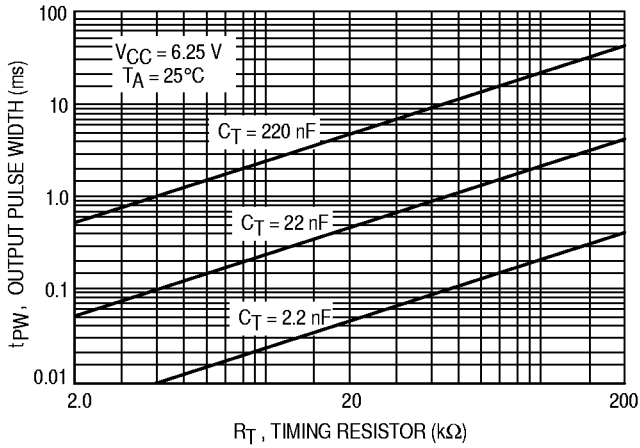

Figure 4. f_{out} , Pulse Width Change versus Temperature

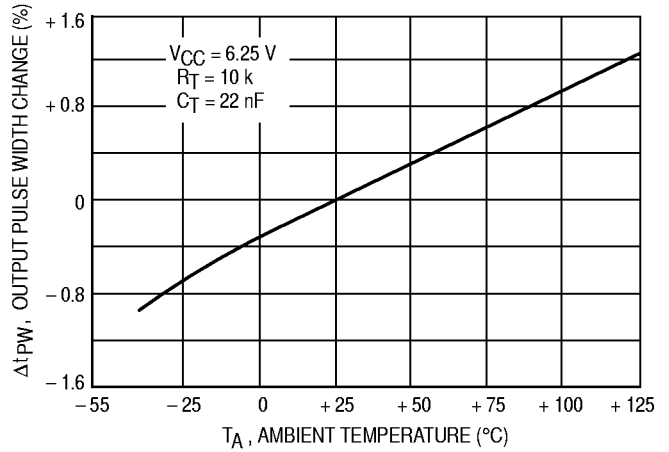

Figure 5. f_{out} , Pulse Width Change versus Supply Voltage

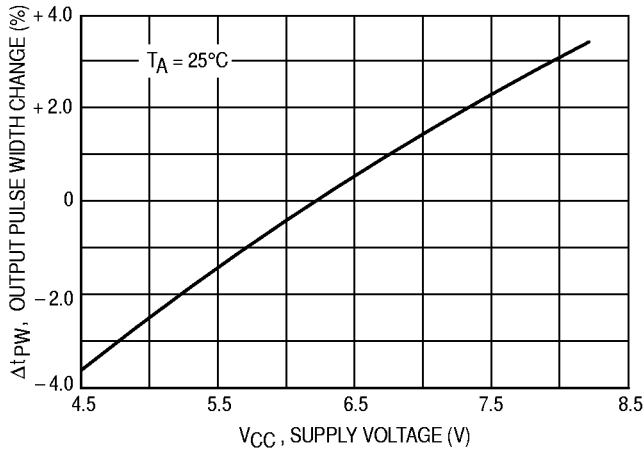

Figure 6. Supply Current versus Supply Voltage

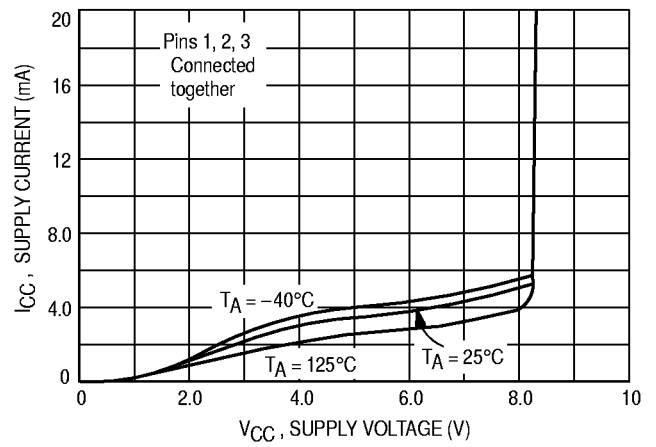

Figure 7. f_{out} , Saturation versus Load Current

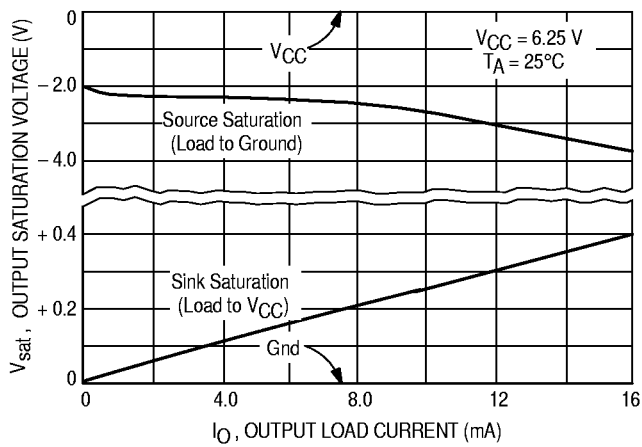
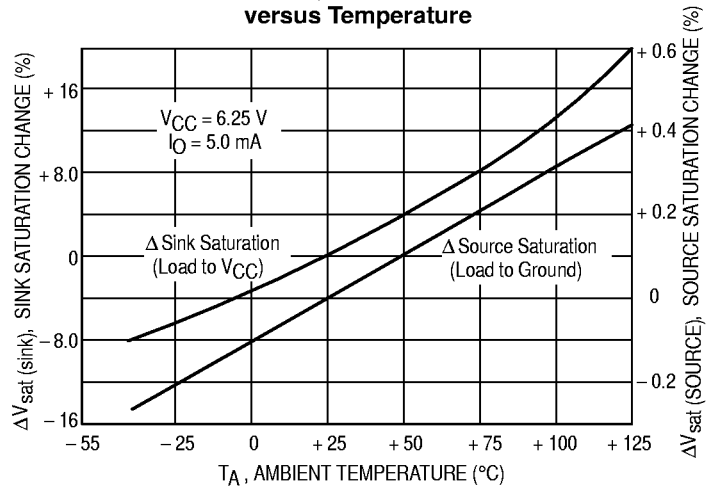

Figure 8. f_{out} , Saturation Change versus Temperature



MC33039

OUTLINE DIMENSIONS

P SUFFIX PLASTIC PACKAGE CASE 626-05 ISSUE K

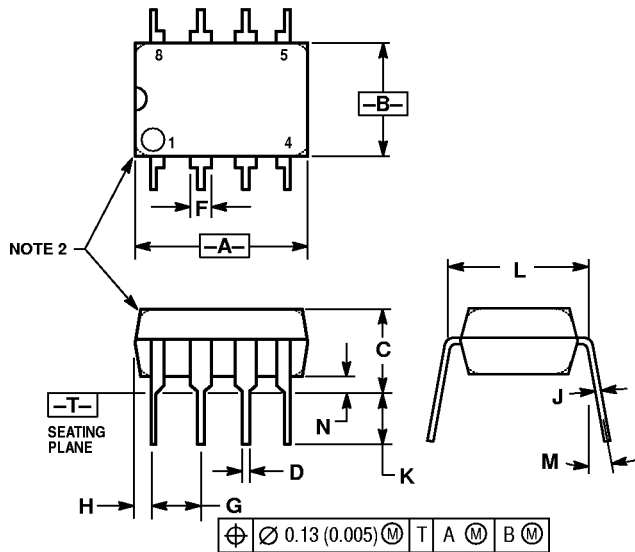

NOTES:

1. DIMENSION L TO CENTER OF LEAD WHEN FORMED PARALLEL.
2. PACKAGE CONTOUR OPTIONAL (ROUND OR SQUARE CORNERS).
3. DIMENSIONING AND TOLERANCING PER ANSI Y14.5M, 1982.

DIM	MILLIMETERS		INCHES	
	MIN	MAX	MIN	MAX
A	9.40	10.16	0.370	0.400
B	6.10	6.60	0.240	0.260
C	3.94	4.45	0.155	0.175
D	0.38	0.51	0.015	0.020
F	1.02	1.78	0.040	0.070
G	2.54 BSC		0.100 BSC	
H	0.76	1.27	0.030	0.050
J	0.20	0.30	0.008	0.012
K	2.92	3.43	0.115	0.135
L	7.62 BSC		0.300 BSC	
M	—		10°	
N	0.76	1.01	0.030	0.040

D SUFFIX PLASTIC PACKAGE CASE 751-05 ISSUE N (SO-8)

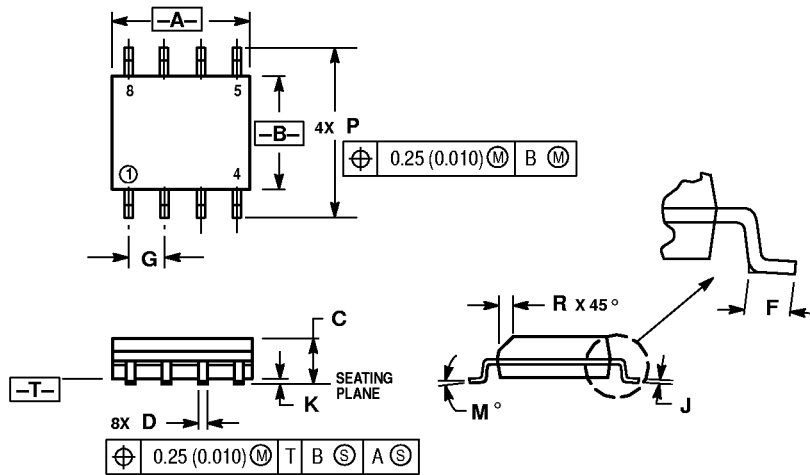

NOTES:

1. DIMENSIONING AND TOLERANCING PER ANSI Y14.5M, 1982.
2. CONTROLLING DIMENSION: MILLIMETER.
3. DIMENSIONS A AND B DO NOT INCLUDE MOLD PROTRUSION.
4. MAXIMUM MOLD PROTRUSION 0.15 (0.006) PER SIDE.
5. DIMENSION D DOES NOT INCLUDE DAMBAR PROTRUSION. ALLOWABLE DAMBAR PROTRUSION SHALL BE 0.127 (0.005) TOTAL IN EXCESS OF THE D DIMENSION AT MAXIMUM MATERIAL CONDITION.

DIM	MILLIMETERS		INCHES	
	MIN	MAX	MIN	MAX
A	4.80	5.00	0.189	0.196
B	3.80	4.00	0.150	0.157
C	1.35	1.75	0.054	0.068
D	0.35	0.49	0.014	0.019
F	0.40	1.25	0.016	0.049
G	1.27 BSC		0.050 BSC	
J	0.18	0.25	0.007	0.009
K	0.10	0.25	0.004	0.009
M	0°		7°	
P	5.80	6.20	0.229	0.244
R	0.25	0.50	0.010	0.019