

PRELIMINARY 4192

12-Bit Fast A/D Converter

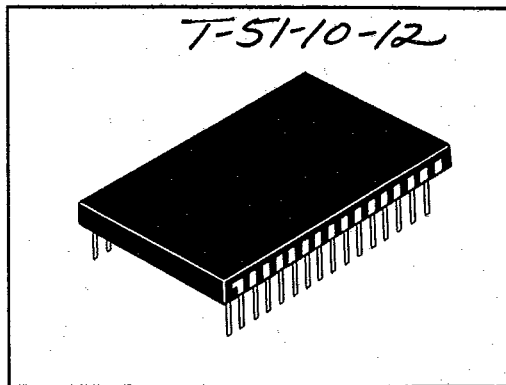

The 4192 is intended for applications requiring extremely fast, precise analog-to-digital conversion. The maximum conversion speed is 500ns. Proven monolithic circuits and recent advanced designs are combined to produce a device with improved performance but low cost. The 4192 is manufactured using thick and thin film hybrid technology.

Three selectable input ranges are provided: 0 to +10V; ±10V and 0 to +20V. Factory laser trims adjust all parameters so that most applications will require no additional adjustment. Optional gain and offset adjustments are provided for the user's convenience.

Conversions are initiated by a single pulse 50ns minimum. Two timing signals are produced by the converter. End of convert signals data is ready at the outputs. Sample/Hold signals an external Track/Hold to begin acquiring the next analog data point. This technique reduces the overall conversion time for a combined A/D and T/H, thus increasing throughput.

Tri-state outputs are supplied for bus applications. Also included is an overflow pin. Overflow indicates the analog signal being converted was outside the range of the converter. Power requirements are ±15 and ±5V. Power consumption is typically 1.5W.

The standard 4192 is specified for 0°C to +70°C operation. The 4192-83 is fully specified for operation over the -55°C to +125°C temperature range and meets the high reliability requirements of MIL-STD-883C, Class "B". May also be ordered screened to Class "S".

FEATURES

- 12-Bit Resolution
- 500ns Max. Conversion Time
- Low Power, 1.8W Max.
- Three-State Output Buffers
- -55°C to +125°C Operation

APPLICATIONS

- Medical Instrumentation
- High Speed Data Acquisition Systems

PACKAGE DIMENSIONS INCHES (MM)

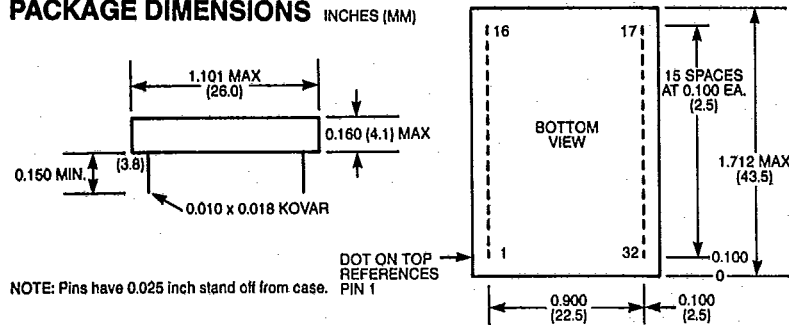

PIN DESIGNATIONS

1. +10V REF	17. SAMPLE/HOLD CONTROL
2. RANGE	18. EOC (STATUS)
3. INPUT HI	19. BIT 12 (LSB)
4. INPUT LOW	20. BIT 11
5. OFFSET ADJUST	21. BIT 10
6. NO CONNECTION	22. BIT 9
7. COMP BIN	23. BIT 8
8. OVERFLOW	24. BIT 7
9. ENABLE (BITS 7-12)	25. BIT 6
10. ENABLE (BITS 1-6 & OF)	26. BIT 5
11. +5V POWER	27. BIT 4
12. DIGITAL GROUND	28. BIT 3
13. +15V POWER	29. BIT 2
14. -15V POWER	30. BIT 1 (MSB)
15. -5V POWER	31. START CONVERT
16. ANALOG GROUND	32. GAIN ADJUST

4192

ABSOLUTE MAXIMUM RATINGS

+15V Supply (Pin 13)
 -15V Supply (Pin 14)
 +5V Supply (Pin 11)
 -5V Supply (Pin 15)
 Digital Inputs: (Pins 7, 9, 13, 31)
 Analog Input: (Pin 3)

0V to +18V
 0V to -18V
 -0.5V to +7.0V
 +0.5V to -7.0V
 -0.3V to +6.0V
 ±25V

SPECIFICATIONS ($T_A = +25^\circ\text{C}$, ±15V and ±5V supplies unless otherwise indicated).

PARAMETER	MIN.	TYP.	MAX.	UNITS
ANALOG INPUTS				
Input Voltage Range	---	0 to +10	---	V
	---	0 to +20	---	V
	---	±10	---	V
Input Impedance: Unipolar	3.75	5	---	k Ω
Bipolar	1.75	2.5	---	k Ω
Analog Input Settling Time	---	---	150	nsec
DIGITAL INPUTS				
Input Capacitance	---	---	50	pf
Logic Levels: Logic "1"	2.4	---	---	V
Logic "0"	---	---	0.5	V
Logic Loading: Logic "1"	---	---	5	μA
Logic "0"	---	---	-100	μA
Start Convert Pulse Width	50	---	---	nsec
Start Convert Rise & Fall Time	---	---	30	nsec
DIGITAL OUTPUTS				
Output Coding: (Pin 7 - High) (Pin 7 - Low)		Straight Binary/Offset Binary Complementary Binary		
Logic Levels: Logic "1"	2.4	---	---	V
Logic "0"	---	---	0.5	V
Logic Loading: Logic "1"	---	---	-160	μA
Logic "0"	---	---	6.0	mA
Start Convert Low to EOC High Propagation Delay	---	---	25	nsec
Start Convert Low to Previous Output Data Invalid	350	---	---	nsec
Data Valid before EOC goes Low	25	---	---	nsec
Enable to Output to Data Valid Propagation Delay	---	---	10	nsec
TRANSFER CHARACTERISTICS				
Integral Nonlinearity:				
+25°C	---	---	±½	LSB
0°C to +70°C 4192	---	---	±½	LSB
-55°C to +125°C 4192-83	---	---	±2	LSB
Integral Nonlinearity Tempco	---	---	±3	ppm/C
Differential Nonlinearity:				
+25°C	---	---	±½	LSB
0°C to +70°C 4192	---	---	±½	LSB
-55°C to +125°C 4192-83	---	---	±1	LSB
Differential Nonlinearity Tempco	---	---	±2	ppm/C
Full Scale Absolute Accuracy:				
+25°C	---	---	±0.05	%FSR
0°C to +70°C 4192 TBD	---	---	.2	%FSR
-55°C to +125°C 4192-83 TBD	---	---	.4	%FSR
No Missing Codes (12 Bits):				
0°C to +70°C 4192	Over the Operating Temperature Range			
-55°C to +125°C 4192-83				
Unipolar Zero Error, +25°C	---	---	±0.01	%FSR
Unipolar Zero Tempco	---	---	±13	ppm/C
Bipolar Offset Error, +25°C	---	---	±0.01	%FSR
Bipolar Offset Tempco	---	---	±13	ppm/C
Gain Error, +25°C	---	---	±0.01	%FSR
Gain Tempco	---	±17	±35	ppm/C

SPECIFICATIONS (T_A = +25°C, ±15V and ±5V supplies unless otherwise indicated).

PARAMETER	MIN.	TYP.	MAX.	UNITS
DYNAMIC CHARACTERISTICS				
Conversion Time:				
4192:				
+25°C	---	---	500	nsec
0°C to +70°C	---	---	550	nsec
4192-83				
+25°C	---	---	550	nsec
0°C to +70°C	---	---	600	nsec
-55°C to +125°C	---	---	650	nsec
Conversion Rate (Dynamic Inputs):				
4192:				
+25°C	1.6	---	---	MHz
0°C to +70°C	1.5	---	---	MHz
4192-83				
+25°C	1.5	---	---	MHz
0°C to +70°C	1.4	---	---	MHz
-55°C to +125°C	1.3	---	---	MHz
Conversion Rate (Static Input):				
4192:				
+25°C	2.0	---	---	MHz
0°C to +70°C	1.8	---	---	MHz
4192-83				
+25°C	1.8	---	---	MHz
0°C to +70°C	1.6	---	---	MHz
-55°C to +125°C	1.5	---	---	MHz
REFERENCE OUTPUT				
Internal Reference:				
Voltage, +25°C	9.9	---	10.1	V
Drift	---	---	30	ppm/C
External Current With no Performance Degradation Over Temperature				
	---	---	1.5	mA
POWER SUPPLIES				
Power Supply Range: +15V Supply				
	+14.25	+15	+15.75	V
-15V Supply				
	-14.25	-15	-15.75	V
+5V Supply				
	+4.75	+5	+5.25	V
-5V Supply				
	-4.75	-5	-5.25	V
Power Supply Rejection	---	---	0.01	%FSR/%Vs
Power Dissipation	---	1.4	1.8	W
Power Supply Current: +15V Supply				
	---	---	20	mA
-15V Supply				
	---	---	22	mA
+5V Supply				
	---	---	210	mA
-5V Supply				
	---	---	26	mA

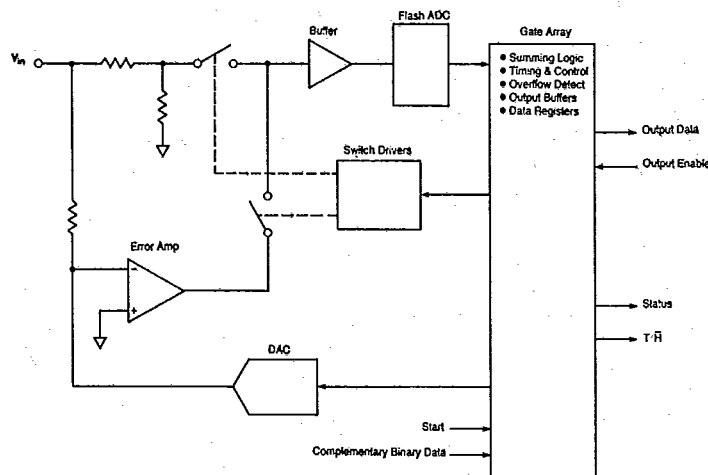

Figure 1. Functional Block Diagram