

**PM5365**

**TEMAP**

**VT/TU MAPPER AND M13 MULTIPLEXER**

**DATASHEET**

**PROPRIETARY AND CONFIDENTIAL**

**PRELIMINARY**

**ISSUE 2: FEBRUARY 2000**

PRELIMINARY  
DATASHEET  
PMC-1991148



PM5365 TEMAP

ISSUE 2

VT/TU MAPPER AND M13 MUX

## CONTENTS

1	FEATURES .....	1
2	APPLICATIONS .....	11
3	REFERENCES.....	12
4	APPLICATION EXAMPLES .....	16
5	BLOCK DIAGRAM .....	17
5.1	TOP LEVEL BLOCK DIAGRAM .....	17
5.2	VT/TU MAPPER MODE BLOCK DIAGRAM .....	19
5.3	DS3 FRAMER ONLY BLOCK DIAGRAM .....	19
6	DESCRIPTION .....	21
7	PIN DIAGRAM .....	25
8	PIN DESCRIPTION.....	26
9	FUNCTIONAL DESCRIPTION.....	56
9.1	T1 FRAMER (T1-FRMR).....	56
9.2	E1 FRAMER (E1-FRMR).....	56
9.3	PERFORMANCE MONITOR COUNTERS (T1/E1-PMON).....	63
9.4	T1 ALARM INTEGRATOR (ALMI).....	64
9.5	RECEIVE AND TRANSMIT DIGITAL JITTER ATTENUATOR (RJAT, TJAT).....	64
9.6	TIMING OPTIONS (TOPS) .....	71
9.7	PSEUDO RANDOM BINARY SEQUENCE GENERATION AND DETECTION (PRBS) .....	72
9.8	PSEUDO RANDOM PATTERN GENERATION AND DETECTION (PRGD).....	72
9.9	DS3 FRAMER (DS3-FRMR) .....	72

---

9.10	PERFORMANCE MONITOR ACCUMULATOR (DS3-PMON) ....	75
9.11	DS3 TRANSMITTER (DS3-TRAN).....	75
9.12	M23 MULTIPLEXER (MX23).....	76
9.13	DS2 FRAMER (DS2-FRMR) .....	77
9.14	M12 MULTIPLEXER (MX12).....	79
9.15	TRIBUTARY PAYLOAD PROCESSOR (VTPP) .....	80
9.16	RECEIVE TRIBUTARY PATH OVERHEAD PROCESSOR (RTOP) .....	83
9.17	RECEIVE TRIBUTARY DEMAPPER (RTDM).....	85
9.18	PARALLEL IN TO SERIAL OUT CONVERTER (PISO).....	87
9.19	DS3 MAPPER DROP SIDE (D3MD).....	88
9.20	TRANSMIT TRIBUTARY PATH OVERHEAD PROCESSOR (TTOP).....	92
9.21	TRANSMIT REMOTE ALARM PROCESSOR (TRAP).....	93
9.22	TRANSMIT TRIBUTARY MAPPER (TTMP).....	94
9.23	SERIAL IN TO PARALLEL OUT CONVERTER (SIPO).....	95
9.24	DS3 MAPPER ADD SIDE (D3MA) .....	95
9.25	EGRESS SYSTEM INTERFACE (ESIF) .....	97
9.26	INGRESS SYSTEM INTERFACE (ISIF) .....	98
9.27	EXTRACT SCALEABLE BANDWIDTH INTERCONNECT (EXSBI) .....	99
9.28	INSERT SCALEABLE BANDWIDTH INTERCONNECT (INSBI)	99
9.29	SCALEABLE BANDWIDTH INTERCONNECT PISO (SBIPISO)	100
9.30	SCALEABLE BANDWIDTH INTERCONNECT SIPO (SBISIPO)	100
9.31	JTAG TEST ACCESS PORT .....	100

---

9.32	MICROPROCESSOR INTERFACE .....	100
10	NORMAL MODE REGISTER DESCRIPTION .....	126
11	TEST FEATURES DESCRIPTION .....	127
11.1	JTAG TEST PORT .....	129
12	OPERATION .....	141
12.1	DS3 FRAME FORMAT .....	141
12.2	SERVICING INTERRUPTS .....	143
12.3	USING THE PERFORMANCE MONITORING FEATURES .....	143
12.4	T1/E1 STREAM LOOPBACK MODES .....	148
12.5	DS3 LOOPBACK MODES .....	150
12.6	TELECOM BUS MAPPER/DEMAPPING LOOPBACK MODES .....	153
12.7	SBI BUS DATA FORMATS .....	154
12.8	PRGD PATTERN GENERATION .....	168
12.9	JTAG SUPPORT .....	172
13	FUNCTIONAL TIMING .....	181
13.1	DS3 LINE SIDE INTERFACE TIMING .....	181
13.2	DS3 SYSTEM SIDE INTERFACE TIMING .....	182
13.3	TELECOM DROP BUS INTERFACE TIMING .....	184
13.4	TELECOM ADD BUS INTERFACE TIMING .....	187
13.5	SONET/SDH SERIAL ALARM PORT TIMING .....	189
13.6	SBI DROP BUS INTERFACE TIMING .....	190
13.7	SBI ADD BUS INTERFACE TIMING .....	191
13.8	EGRESS SERIAL CLOCK AND DATA INTERFACE TIMING .....	192
13.9	INGRESS SERIAL CLOCK AND DATA INTERFACE TIMING .....	193

---

14	ABSOLUTE MAXIMUM RATINGS .....	194
15	D.C. CHARACTERISTICS .....	195
16	MICROPROCESSOR INTERFACE TIMING CHARACTERISTICS .....	197
17	TEMAP TIMING CHARACTERISTICS .....	201
18	ORDERING AND THERMAL INFORMATION.....	221
19	MECHANICAL INFORMATION .....	222

**LIST OF FIGURES**

FIGURE 1	- DS3 MULTIPLEXING APPLICATION.....	16
FIGURE 2	- HIGH DENSITY FRAME RELAY APPLICATION .....	16
FIGURE 3	- TEMAP BLOCK DIAGRAM.....	18
FIGURE 4	- VT/TU MAPPER BLOCK DIAGRAM .....	19
FIGURE 5	- DS3 FRAMER ONLY MODE BLOCK DIAGRAM.....	20
FIGURE 6	- PIN DIAGRAM .....	25
FIGURE 7	- CRC MULTIFRAME ALIGNMENT ALGORITHM .....	60
FIGURE 8	- DJAT JITTER TOLERANCE T1 MODES .....	67
FIGURE 9	- DJAT JITTER TOLERANCE E1 MODES.....	68
FIGURE 10-	DJAT MINIMUM JITTER TOLERANCE VS. XCLK ACCURACY T1 MODES	69
FIGURE 11-	DJAT MINIMUM JITTER TOLERANCE VS. XCLK ACCURACY E1 MODES	69
FIGURE 12-	DJAT JITTER TRANSFER T1 MODES .....	70
FIGURE 13-	DJAT JITTER TRANSFER E1 MODES .....	71
FIGURE 14-	CLOCK MASTER: CLEAR CHANNEL .....	97
FIGURE 15-	CLOCK SLAVE: CLEAR CHANNEL .....	98

---

FIGURE 16- CLOCK MASTER: CLEAR CHANNEL .....	98
FIGURE 17: DS3 FRAME STRUCTURE.....	141
FIGURE 18- FER COUNT VS. BER (E1 MODE) .....	145
FIGURE 19- CRCE COUNT VS. BER (E1 MODE) .....	146
FIGURE 20- FER COUNT VS. BER (T1 ESF MODE).....	146
FIGURE 21- CRCE COUNT VS. BER (T1 ESF MODE).....	147
FIGURE 22- CRCE COUNT VS. BER (T1 SF MODE) .....	148
FIGURE 23: T1/E1 LINE LOOPBACK.....	149
FIGURE 24: T1/E1 DIAGNOSTIC DIGITAL LOOPBACK .....	150
FIGURE 25: DS3 DIAGNOSTIC LOOPBACK DIAGRAM.....	151
FIGURE 26: DS3 LINE LOOPBACK DIAGRAM.....	152
FIGURE 27: DS2 LOOPBACK DIAGRAM.....	152
FIGURE 28: TELECOM DIAGNOSTIC LOOPBACK DIAGRAM .....	153
FIGURE 29: TELECOM LINE LOOPBACK DIAGRAM.....	154
FIGURE 30: PRGD PATTERN GENERATOR .....	169
FIGURE 31: BOUNDARY SCAN ARCHITECTURE .....	173
FIGURE 32: TAP CONTROLLER FINITE STATE MACHINE .....	175
FIGURE 33: INPUT OBSERVATION CELL (IN_CELL) .....	178
FIGURE 34: OUTPUT CELL (OUT_CELL).....	179
FIGURE 35: BIDIRECTIONAL CELL (IO_CELL).....	179
FIGURE 36: LAYOUT OF OUTPUT ENABLE AND BIDIRECTIONAL CELLS	180
FIGURE 37: RECEIVE BIPOLAR DS3 STREAM .....	181
FIGURE 38: RECEIVE UNIPOLAR DS3 STREAM .....	181
FIGURE 39: TRANSMIT BIPOLAR DS3 STREAM.....	182

---

FIGURE 40: TRANSMIT UNIPOLAR DS3 STREAM.....	182
FIGURE 41: FRAMER MODE DS3 TRANSMIT INPUT STREAM.....	182
FIGURE 42: FRAMER MODE DS3 TRANSMIT INPUT STREAM WITH TGAPCLK	183
FIGURE 43: FRAMER MODE DS3 RECEIVE OUTPUT STREAM .....	184
FIGURE 44: FRAMER MODE DS3 RECEIVE OUTPUT STREAM WITH RGAPCLK	184
FIGURE 45: TELECOM DROP BUS TIMING - STS-1 SPES / AU3 VCS.....	185
FIGURE 46: TELECOM DROP BUS TIMING - LOCKED STS-1 SPES / AU3 VCS 186	
FIGURE 47: TELECOM DROP BUS TIMING - AU4 VC .....	187
FIGURE 48: OUTPUT BUS TIMING - LOCKED STS-1 SPES / AU3 VCS .....	188
FIGURE 49- OUTPUT BUS TIMING - LOCKED AU4 VC CASE .....	189
FIGURE 50: REMOTE SERIAL ALARM PORT TIMING .....	190
FIGURE 51: SBI DROP BUS T1/E1 FUNCTIONAL TIMING .....	190
FIGURE 52: SBI DROP BUS DS3 FUNCTIONAL TIMING.....	191
FIGURE 53: SBI ADD BUS ADJUSTMENT REQUEST FUNCTIONAL TIMING 192	
FIGURE 54: T1 AND E1 EGRESS INTERFACE CLOCK MASTER: CLEAR CHANNEL MODE .....	192
FIGURE 55: T1 AND E1 EGRESS INTERFACE CLOCK SLAVE: CLEAR CHANNEL MODE .....	193
FIGURE 56: T1 AND E1 INGRESS INTERFACE CLOCK MASTER: CLEAR CHANNEL MODE .....	193
FIGURE 57: DS3 TRANSMIT INTERFACE TIMING .....	203
FIGURE 58: DS3 RECEIVE INTERFACE TIMING .....	206
FIGURE 59: LINE SIDE TELECOM BUS INPUTTIMING .....	208

---

FIGURE 60: TELECOM BUS OUTPUT TIMING .....	209
FIGURE 61: TELECOM BUS TRISTATE OUTPUT TIMING.....	209
FIGURE 62: SBI ADD BUS TIMING .....	211
FIGURE 63: SBI DROP BUS TIMING .....	212
FIGURE 64: SBI DROP BUS COLLISION AVOIDANCE TIMING.....	213
FIGURE 65: XCLK INPUT TIMING.....	213
FIGURE 66: EGRESS INTERFACE INPUT TIMING - CLOCK MASTER : CLEAR CHANNEL MODE .....	214
FIGURE 67: INGRESS INTERFACE TIMING - CLOCK MASTER: CLEAR CHANNEL MODE .....	215
FIGURE 68: TRANSMIT LINE INTERFACE TIMING .....	216
FIGURE 69: REMOTE SERIAL ALARM PORT TIMING .....	218
FIGURE 70: JTAG PORT INTERFACE TIMING.....	220
FIGURE 71: 324 PIN PBGA 23X23MM BODY .....	222

**LIST OF TABLES**

TABLE 1 - E1-FRMR FRAMING STATES .....	61
TABLE 2 - PATH SIGNAL LABEL MISMATCH STATE.....	84
TABLE 3 - ASYNCHRONOUS T1 TRIBUTARY MAPPING .....	85
TABLE 4 - ASYNCHRONOUS E1 TRIBUTARY MAPPING.....	86
TABLE 5 - DESYNCHRONIZER CLOCK GENERATION ALGORITHM .....	88
TABLE 6 - ASYNCHRONOUS DS3 MAPPING TO STS-1 (STM-0/AU3).....	88
TABLE 7 - DS3 AIS FORMAT.....	89
TABLE 8 - DS3 DESYNCHRONIZER CLOCK GAPPING ALGORITHM.....	92
TABLE 9 - DS3 SYNCHRONIZER BIT STUFFING ALGORITHM.....	96

---

TABLE 10 - REGISTER MEMORY MAP .....	101
TABLE 11 - INSTRUCTION REGISTER .....	129
TABLE 12 - IDENTIFICATION REGISTER .....	130
TABLE 13 - BOUNDARY SCAN CHAIN.....	130
TABLE 14 - PMON COUNTER SATURATION LIMITS (E1 MODE).....	144
TABLE 15 - PMON COUNTER SATURATION LIMITS (T1 MODE).....	144
TABLE 16 - STRUCTURE FOR CARRYING MULTIPLEXED LINKS .....	156
TABLE 17 - T1/TVT1.5 TRIBUTARY COLUMN NUMBERING .....	156
TABLE 18 - E1/TVT2 TRIBUTARY COLUMN NUMBERING .....	157
TABLE 19: SBI T1/E1 LINK RATE INFORMATION .....	158
TABLE 20: SBI T1/E1 CLOCK RATE ENCODING .....	159
TABLE 21: DS3 LINK RATE INFORMATION .....	159
TABLE 22: DS3 CLOCK RATE ENCODING.....	159
TABLE 23 - T1 FRAMING FORMAT .....	160
TABLE 24 - E1 FRAMING FORMAT .....	162
TABLE 25 - DS3 FRAMING FORMAT .....	164
TABLE 26 - DS3 BLOCK FORMAT.....	164
TABLE 27 - DS3 MULTI-FRAME STUFFING FORMAT.....	164
TABLE 28 - TRANSPARENT VT1.5/TU11 FORMAT .....	165
TABLE 29 - TRANSPARENT VT2/TU12 FORMAT .....	167
TABLE 30: PSEUDO RANDOM PATTERN GENERATION (PS BIT = 0) .....	171
TABLE 31: REPETITIVE PATTERN GENERATION (PS BIT = 1) .....	172
TABLE 32 - ABSOLUTE MAXIMUM RATINGS.....	194
TABLE 33 - D.C. CHARACTERISTICS.....	195

---

TABLE 34: MICROPROCESSOR INTERFACE READ ACCESS .....	197
TABLE 35: MICROPROCESSOR INTERFACE WRITE ACCESS .....	199
TABLE 36: RTSB TIMING.....	201
TABLE 37: DS3 TRANSMIT INTERFACE TIMING.....	201
TABLE 38: DS3 RECEIVE INTERFACE TIMING .....	205
TABLE 39: LINE SIDE TELECOM BUS INPUT TIMING (FIGURE 62).....	207
TABLE 40 – TELECOM BUS OUTPUT TIMING (FIGURE 63 TO FIGURE 64)	208
TABLE 41: SBI ADD BUS TIMING (FIGURE 62).....	210
TABLE 42 – SBI DROP BUS TIMING (FIGURE 63 TO FIGURE 64) .....	211
TABLE 43: XCLK INPUT (FIGURE 65).....	213
TABLE 44: EGRESS INTERFACE INPUT TIMING - CLOCK MASTER : CLEAR CHANNEL MODE (FIGURE 66 .....	214
TABLE 45: INGRESS INTERFACE TIMING - CLOCK MASTER: CLEAR CHANNEL MODE (FIGURE 67) .....	215
TABLE 46: TRANSMIT LINE INTERFACE TIMING (FIGURE 68).....	216
TABLE 47: REMOTE SERIAL ALARM PORT TIMING .....	217
TABLE 48: JTAG PORT INTERFACE.....	219
TABLE 49 - ORDERING AND THERMAL INFORMATION .....	221

## 1 FEATURES

- SONET/SDH VT1.5/VT2/TU11/TU12 bit asynchronous mapper, a full featured M13 multiplexer with DS3 framer, and a SONET/SDH DS3 mapper in a single monolithic device for terminating DS3 multiplexed T1 streams, SONET/SDH mapped T1 streams or SONET/SDH mapped E1 streams.
- Five fundamental operating modes:
  - Single STS-1, AU3 or TUG3 Bit Asynchronous VT1.5 or TU-11 Mapper with ingress or egress per tributary link monitoring for 28 T1s.
  - Single STS-1, AU3 or TUG3 Bit Asynchronous VT2 or TU-12 Mapper with ingress or egress per tributary link monitoring for 21 E1s or 21 T1s.
  - DS3 M13 Multiplexer with ingress or egress per link monitoring for 28 T1s.
  - DS3 G.747 Multiplexer with ingress or egress per link monitoring for 21 E1s. This E1 mode of operation is restricted to using the serial clock and data system interfaces.
  - Transmultiplexing function for 28 T1s between DS3 M13 Multiplexer and SONET/SDH VT/TU Mapper. Ingress or egress per link monitoring for 28 T1s
- Up to 28 VT1.5/TU11 or 21 VT2/TU12 tributaries can be passed between the line SONET/SDH bus and the SBI bus as transparent virtual tributaries with pointer processing.
- When adding and dropping T1 or E1 tributaries the mapper and demapper blocks allow for up to 28 VT1.5/TU11 or 21 VT2/TU12 tributaries to be processed from any tributary location within the full STS-3/STM-1. On the telecom DROP bus side this requires that the STS-3/STM-1 be in locked mode such that the J1 bytes immediately follow the C1 bytes.
- Supports a byte serial Scalable Bandwidth Interconnect (SBI) bus interface for high density system side device interconnection of up to 84 T1 streams, 63 E1 streams, 3 DS3 streams or 3 E3 streams. This interface also supports transparent virtual tributaries when used with the SONET/SDH mapper.
- Provides jitter attenuation in the T1 or E1 receive and transmit directions.
- Provides two independent de-jittered T1 or E1 recovered clocks for system timing and redundancy.

- Provides an on-board programmable binary sequence generator and detector for error testing at DS3 rates. Includes support for patterns recommended in ITU-T O.151.
- Also provides PRBS generators and detectors on each tributary for error testing at DS1 and E1 rates as recommended in ITU-T O.151 and O.152.
- Supports the M23 and C-bit parity DS3 formats.
- Standalone unchannelized DS3 framer mode for access to the entire DS3 payload.
- When configured to operate as a DS3 Framer, gapped transmit and receive clocks can be optionally generated for interface to link layer devices which only need access to payload data bits.
- DS3 Transmit clock source can be selected from either an external oscillator or from the receive side clock (loop-timed).
- Provides a SONET/SDH Add/Drop bus interface with integrated VT1.5, TU-11, VT2 and TU-12 mapper for T1 and E1 streams. Also provides a DS3 mapper.
- Register level compatibility with the PM8315 TEMUX, PM4388 TOCTL Octal T1 Framer, the PM6388 EOCTL Octal E1 Framer, the PM4351 COMET E1/T1 transceiver and the PM8313 D3MX M13 Multiplexer/Demultiplexer.
- Provides a generic 8-bit microprocessor bus interface for configuration, control and status monitoring.
- Provides a standard 5 signal P1149.1 JTAG test port for boundary scan board test purposes.
- Low power 2.5V/3.3V CMOS technology. All pins are 5V tolerant except for the SBI bus signals which are 3.3V TTL compatible.
- 324-pin fine pitch PBGA package (23mm x 23mm). Supports industrial temperature range (-40°C to 85°C) operation.

**Each one of 28 T1 receiver sections:**

- Frames to DS-1 signals for performance monitoring in SF and ESF formats.
- Frames to TTC JT-G.704 multiframe formatted J1 signals for performance monitoring.

- Accepts gapped data streams to support higher rate demultiplexing.
- Provides Red, Yellow, and AIS alarm integration.
- Provides performance monitoring counters sufficiently large as to allow performance monitor counter polling at a minimum rate of once per second. Optionally, updates the performance monitoring counters and interrupts the microprocessor once per second, timed to the receive line.
- A pseudo-random sequence user selectable from  $2^{11} - 1$ ,  $2^{15} - 1$  or  $2^{20} - 1$ , may be detected in the T1 stream in either the ingress or egress directions. The detector counts pattern errors using a 24-bit non-saturating PRBS error counter.
- Line side interface is either from the DS3 interface via the M13 multiplex or from the SONET/SDH Drop bus via the VT1.5, TU-11, VT2 or TU-12 demapper.
- System side interface is either serial clock and data or SBI bus.
- Detects the “Japanese Yellow” alarm.
- Provides external access for up to two de-jittered recovered T1 clocks.

**Each one of 21 E1 receiver sections:**

- Frames to ITU-T G.704 basic and CRC-4 multiframe formatted E1 signals. The framing procedures are consistent ITU-T G.706 specifications.
- Provides performance monitoring counters sufficiently large as to allow performance monitor counter polling at a minimum rate of once per second. Optionally, updates the performance monitoring counters and interrupts the microprocessor once per second, timed to the receive line.
- A pseudo-random sequence user selectable from  $2^{11} - 1$ ,  $2^{15} - 1$  or  $2^{20} - 1$ , may be detected in the E1 stream in either the ingress or egress directions. The detector counts pattern errors using a 24-bit non-saturating PRBS error counter.
- Line side interface is from the SONET/SDH Drop bus via the VT2 or TU-12 demapper.
- System side interface is either serial clock and data or SBI bus.
- Provides external access for up to two de-jittered recovered E1 clocks.

**SONET/SDH Tributary Path Processing Section:**

- Interfaces with a byte wide Telecom Add/Drop bus, interfacing directly with the PM5362 TUPP-PLUS and PM5342 SPECTRA-155.
- Compensates for pleisiochronous relationships between incoming and outgoing higher level (STS-1, AU4, AU3) synchronous payload envelope frame rates through processing of the lower level tributary pointers.
- Optionally frames to the H4 byte in the path overhead to determine tributary multi-frame boundaries and generates change of loss-of-frame status interrupts.
- Detects loss of pointer (LOP) and re-acquisition for each tributary and optionally generates interrupts.
- Detects tributary path alarm indication signal (AIS) and return to normal state for each tributary and optionally generates interrupts
- Detects tributary elastic store underflow and overflow and optionally generates interrupts.
- Provides individual tributary path signal label register that hold the expected label and detects tributary path signal label mismatch alarms (PSLM) and return to matched state for each tributary and optionally generates interrupts.
- Detects tributary path signal label unstable alarms (PSLU) and return to stable state for each tributary and optionally generates interrupts.
- Detects assertion and removal of tributary extended remote defect indications (RDI) for each tributary and optionally generates interrupts.
- Calculates and compares the tributary path BIP-2 error detection code for each tributary and configurable to accumulate the BIP-2 errors on block or bit basis in internal registers.
- Allows insertion of all-zeros or all-ones tributary idle code with unequipped indication and valid pointer into any tributary under SW control.
- Allows SW to force the AIS insertion on a per tributary basis.
- Inserts valid H4 byte and all-zeros fixed stuff bytes. Remaining path overhead bytes (J1, B3, C2,G1, F2, Z3, Z4, Z5) are set to all-zeros.

- Inserts valid pointers and all-zeros transport overhead bytes on the outgoing telecom Add bus, with valid control signals.
- Support in-band error reporting by updating the FEBE, RDI and auxiliary RDI bits in the V5 byte with the status of the incoming stream and remote alarm pins.
- Calculates and inserts the tributary path BIP-2 error detection code for each tributary.

**SONET/SDH VT/TU Mapper Section:**

- Inserts up to 28 bit asynchronous mapped VT1.5 virtual tributaries into an STS-1 SPE from T1 streams.
- Inserts up to 28 bit asynchronous mapped TU-11 tributary units into a STM-1/VC4 TUG3 or STM-1/VC3 from T1 streams.
- Inserts up to 21 bit asynchronous mapped VT2 virtual tributaries into an STS-1 SPE from E1 streams.
- Inserts up to 21 bit asynchronous mapped TU-12 tributary units into an STM-1/VC4 TUG3 or STM-1/VC3 from E1 or T1 streams.
- Bit asynchronous mapping assigns stuff control bits for all streams independently using an all digital control loop. Stuff control bits are dithered to produce fractional mapping jitter at the receiving desynchronizer.
- Sets all fixed stuff bits for asynchronous mappings to zeros or ones per microprocessor control
- Extracts up to 28 bit asynchronous mapped VT1.5 virtual tributaries from an STS-1 SPE into T1 streams via an optional elastic store.
- Extracts up to 28 bit asynchronous mapped TU-11 tributary units from an STM-1/VC4 TUG3 or STM-1/VC3 into T1 streams via an optional elastic store.
- Extracts up to 21 bit asynchronous mapped VT2 virtual tributaries from an STS-1 SPE into E1 streams via an optional elastic store.
- Extracts up to 21 bit asynchronous mapped TU-12 tributary units from an STM-1/VC4 TUG3 or STM-1/VC3 into E1 or T1 streams via an optional elastic store.

- Demapper ignores all transport overhead bytes, path overhead bytes and stuff (R) bits
- Performs majority vote C-bit decoding to detect stuff requests.

**SONET/SDH DS3 Mapper Section:**

- Maps a DS3 stream into an STS-1 SPE (AU3).
- Sets all fixed stuff (R) bits to zeros or ones per microprocessor control
- Extracts a DS3 stream from an STS-1 SPE (AU3).
- Demapper ignores all transport overhead bytes, path overhead bytes and stuff (R) bits
- Performs majority vote C-bit decoding to detect stuff requests
- Complies with DS3 to STS-1 asynchronous mapping standards

**DS3 Receiver Section:**

- Frames to a DS3 signal with a maximum average reframe time of less than 1.5 ms (as required by TR-TSY-000009 Section 4.1.2 and TR-TSY-000191 Section 5.2).
- Decodes a B3ZS-encoded signal and indicates line code violations. The definition of line code violation is software selectable.
- Provides indication of M-frame boundaries from which M-subframe boundaries and overhead bit positions in the DS3 stream can be determined by external processing.
- Detects the DS3 alarm indication signal (AIS) and idle signal. Detection algorithms operate correctly in the presence of a  $10^{-3}$  bit error rate.
- Extracts valid X-bits and indicates far end receive failure (FERF).
- Accumulates up to 65,535 line code violation (LCV) events per second, 65,535 P-bit parity error events per second, 1023 F-bit or M-bit (framing bit) events per second, 65,535 excessive zero (EXZ) events per second, and when enabled for C-bit parity mode operation, up to 16,383 C-bit parity error events per second, and 16,383 far end block error (FEBE) events per second.

- Detects and validates bit-oriented codes in the C-bit parity far end alarm and control channel.
- Terminates the C-bit parity path maintenance data link with an integral HDLC receiver having a 128-byte deep FIFO buffer with programmable interrupt threshold. Supports polled or interrupt-driven operation. Selectable none, one or two address match detection on first byte of received packet.
- Programmable pseudo-random test-sequence detection—(up to  $2^{32} - 1$  bit length patterns conforming to ITU-T O.151 standards) and analysis features.

**DS3 Transmit Section:**

- Provides the overhead bit insertion for a DS3 stream.
- Provides a bit serial clock and data interface, and allows the M-frame boundary and/or the overhead bit positions to be located via an external interface
- Provides B3ZS encoding.
- Generates an B3ZS encoded 100... repeating pattern to aid in pulse mask testing.
- Inserts far end receive failure (FERF), the DS3 alarm indication signal (AIS) and the idle signal when enabled by internal register bits.
- Provides optional automatic insertion of far end receive failure (FERF) on detection of loss of signal (LOS), out of frame (OOF), alarm indication signal (AIS) or red alarm condition.
- Provides diagnostic features to allow the generation of line code violation error events, parity error events, framing bit error events, and when enabled for the C-bit parity application, C-bit parity error events, and far end block error (FEBE) events.
- Supports insertion of bit-oriented codes in the C-bit parity far end alarm and control channel.
- Optionally inserts the C-bit parity path maintenance data link with an integral HDLC transmitter. Supports polled and interrupt-driven operation.
- Provides programmable pseudo-random test sequence generation (up to  $2^{32} - 1$  bit length sequences conforming to ITU-T O.151 standards) or any

repeating pattern up to 32 bits. The test pattern can be framed or unframed. Diagnostic abilities include single bit error insertion or error insertion at bit error rates ranging from  $10^{-1}$  to  $10^{-7}$ .

**M23 Multiplexer Section:**

- Multiplexes 7 DS2 bit streams into a single M23 format DS3 bit stream.
- Performs required bit stuffing/destuffing including generation and interpretation of C-bits.
- Includes required FIFO buffers for rate adaptation in the multiplex path.
- Allows insertion and detection of per DS2 payload loopback requests encoded in the C-bits to be activated under microprocessor control.
- Internally generates DS2 clock for use in integrated M13 or C-bit parity multiplex applications. Alternatively accepts external DS2 clock reference.
- Allows per DS2 alarm indication signal (AIS) to be activated or cleared for either direction under microprocessor control.
- Allows DS2 alarm indication signal (AIS) to be activated or cleared in the demultiplex direction automatically upon loss of DS3 frame alignment or signal.
- Supports C-bit parity DS3 format.

**DS2 Framer Section:**

- Frames to a DS2 (ANSI T1.107 section 8) signal with a maximum average reframe time of less than 7 ms (as required by TR-TSY-000009 Section 4.1.2 and TR-TSY-000191 Section 5.2).
- Detects the DS2 alarm indication signal (AIS) in 9.9 ms in the presence of a  $10^{-3}$  bit error rate.
- Extracts the DS2 X-bit remote alarm indication (RAI) bit and indicates far end receive failure (FERF).
- Accumulates up to 255 DS2 M-bit or F-bit error events per second.

**DS2 Transmitter Section:**

- Generates the required X, F, and M bits into the transmitted DS2 bit stream. Allows inversion of inserted F or M bits for diagnostic purposes.
- Provides for transmission of far end receive failure (FERF) and alarm indication signal (AIS) under microprocessor control.
- Provides optional automatic insertion of far end receive failure (FERF) on detection of out of frame (OOF), alarm indication signal (AIS) or red alarm condition.

**M12 Multiplexer Section:**

- Multiplexes four DS1 bit streams into a single M12 format DS2 bit stream.
- Performs required bit stuffing including generation and interpretation of C-bits.
- Includes required FIFO buffers for rate adaptation in the multiplex path.
- Performs required inversion of second and fourth multiplexed DS1 streams as required by ANSI T1.107 Section 7.2.
- Allows insertion and detection of per DS1 payload loopback requests encoded in the C-bits to be activated under microprocessor control.
- Allows per tributary alarm indication signal (AIS) to be activated or cleared for either direction under microprocessor control.
- Allows automatic tributary AIS to be activated upon DS2 out of frame.

**Scaleable Bandwidth Interconnect (SBI) Bus:**

- Provides a high density byte serial interconnect for all TEMAP links. Utilizes an Add/Drop configuration to asynchronously multiplex up to 84 T1s, 63 E1s or 3 DS3s, equivalent to three TEMAPs, with multiple payload or link layer processors.
- External devices can access TEMAP unframed DS3, framed unchannelized DS3, unframed (clear channel) T1s, unframed (clear channel) E1s, transparent virtual tributaries or transparent tributary units over this interface.

- Transparent VT/TU access can be selected only when tributaries are mapped into SONET/SDH.
- Transparent VT1.5s and TU-11s can be selected on a per tributary basis in combination with framed and unframed T1s. Transparent VT2s and TU-12s can be selected on a per tributary basis in combination with framed and unframed E1s.
- Channel associated signaling bits for channelized T1 and E1 are explicitly identified across bus.
- Transmit timing is mastered either by the TEMAP or a layer 2 device connecting to the SBI bus. Timing mastership is selectable on a per tributary basis, where a tributary is either an individual T1, E1 or a DS3.

## **2 APPLICATIONS**

- SONET/SDH Add Drop Multiplexers
- SONET/SDH Terminal Multiplexers
- M23 Based M13 Multiplexer
- C-Bit Parity Based M13 Multiplexer
- Channelized and Unchannelized DS3 Frame Relay Interfaces

### **3 REFERENCES**

- American National Standard for Telecommunications - Digital Hierarchy - Synchronous DS3 Format Specifications, ANSI T1.103-1993
- American National Standard for Telecommunications – ANSI T1.105 – “Synchronous Optical Network (SONET) – Basic Description Including Multiplex Structure, Rates, and Formats,” October 27, 1995.
- American National Standard for Telecommunications – ANSI T1.105.02 – “Synchronous Optical Network (SONET) – Payload Mappings,” October 27, 1995.
- American National Standard for Telecommunications - Digital Hierarchy - Formats Specification, ANSI T1.107-1995
- American National Standard for Telecommunications - Digital Hierarchy - Layer 1 In-Service Digital Transmission Performance Monitoring, ANSI T1.231-1997
- American National Standard for Telecommunications - Carrier to Customer Installation - DS-1 Metallic Interface Specification, ANSI T1.403-1995
- American National Standard for Telecommunications - Customer Installation-to-Network - DS3 Metallic Interface Specification, ANSI T1.404-1994
- American National Standard for Telecommunications - Integrated Services Digital Network (ISDN) Primary Rate- Customer Installation Metallic Interfaces Layer 1 Specification, ANSI T1.408-1990
- Bell Communications Research, TR-TSY-000009 - Asynchronous Digital Multiplexes Requirements and Objectives, Issue 1, May 1986
- Bell Communications Research - DS-1 Rate Digital Service Monitoring Unit Functional Specification, TA-TSY-000147, Issue 1, October, 1987
- Bell Communications Research - Alarm Indication Signal Requirements and Objectives, TR-TSY-000191 Issue 1, May 1986
- Bell Communications Research - Wideband and Broadband Digital Cross-Connect Systems Generic Criteria, TR-NWT-000233, Issue 3, November 1993
- Bellcore GR-253-CORE – “SONET Transport Systems: Common Criteria,” Issue 2, Revision 1, December 1997.

- Bell Communications Research - Integrated Digital Loop Carrier Generic Requirements, Objectives, and Interface, TR-NWT-000303, Issue 2, December, 1992
- Bell Communications Research - Transport Systems Generic Requirements (TSGR): Common Requirement, TR-TSY-000499, Issue 5, December, 1993
- Bell Communications Research - OTGR: Network Maintenance Transport Surveillance - Generic Digital Transmission Surveillance, TR-TSY-000820, Section 5.1, Issue 1, June 1990
- AT&T - Requirements For Interfacing Digital Terminal Equipment To Services Employing The Extended Superframe Format, TR 54016, September, 1989.
- AT&T - Accunet T1.5 - Service Description and Interface Specification, TR 62411, December, 1990
- ITU Study Group XVIII – Report R 105, Geneva, 9-19 June 1992
- ETSI - ETS 300 011 - ISDN Primary Rate User-Network Interface Specification and Test Principles, 1992.
- ETSI - ETS 300 233 - Access Digital Section for ISDN Primary Rates, May 1994
- ETSI - ETS 300 324-1 - Signaling Protocols and Switching (SPS); V interfaces at the Digital Local Exchange (LE) V5.1 Interface for the Support of Access Network (AN) Part 1: V5.1 Interface Specification, February, 1994.
- ETSI - ETS 300 347-1 - Signaling Protocols and Switching (SPS); V Interfaces at the Digital Local Exchange (LE) V5.2 Interface for the Support of Access Network (AN) Part 1: V5.2 Interface Specification, September 1994.
- ETSI ETS 300 417-1-1 – “Transmission and Multiplexing (TM); Generic Functional Requirements for Synchronous Digital Hierarchy (SDH) equipment; Part 1-1: Generic processes and performance,” January, 1996.
- ETSI, Generic Functional Requirements for Synchronous Digital Hierarchy (SDH) Equipment, Jan 1996
- ITU-T - Recommendation G.704 - Synchronous Frame Structures Used at Primary Hierarchical Levels, July 1995.
- ITU-T - Recommendation G.706 - Frame Alignment and CRC Procedures Relating to G.704 Frame Structures, 1991.

- ITU-T - Recommendation G.732 – Characteristics of Primary PCM Multiplex Equipment Operating at 2048 kbit/s, 1993.
- ITU-T Recommendation G.707 – Network Node Interface for the Synchronous Digital Hierarchy, 1996
- ITU-T Recommendation G.747 – Second Order Digital Multiplex Equipment Operating at 6312kbit/s and Multiplexing Three Tributaries at 2048 kbit/s, 1988
- ITU-T Recommendation G.775, - Loss of Signal (LOS) and Alarm Indication Signal (AIS) Defect Detection and Clearance Criteria, 11/94
- ITU-T Recommendation G.783 – “Characteristics of Synchronous Digital Hierarchy (SDH) Equipment Functional Blocks,” April, 1997.
- ITU-T Recommendation G.823, - The Control of Jitter and Wander within Digital Networks which are Based on the 2048 kbit/s Hierarchy, 03/94
- ITU-T Recommendation G.964, - V-Interfaces at the Digital Local Ex-hange (LE) - V5.1 Interface (Based on 2048 kbit/s) for the Support of Access Network (AN), June 1994.
- ITU-T Recommendation G.965, - V-Interfaces at the Digital Local Ex-hange (LE) - V5.2 Interface (Based on 2048 kbit/s) for the Support of Access Network (AN), March -995.
- ITU-T - Recommendation I.431 - Primary Rate User-Network Interface – Layer 1 Specification, 1993.
- ITU-T Recommendation O.151 – Error Performance Measuring Equipment Operating at the Primary Rate and Above, October 1992
- ITU-T Recommendation O.152 – Error Performance Measuring Equipment for Bit Rates of 64 kbit/s and N x 64 kbit/s, October 1992
- ITU-T Recommendation O.153 - Basic Parameters for the Measurement of Error Performance at Bit Rates below the Primary Rate, October 1992.
- ITU-T Recommendation Q.921 - ISDN User-Network Interface Data Link Layer Specification, March 1993
- International Organization for Standardization, ISO 3309:1984 - High-Level Data Link Control procedures - Frame Structure

- PMC-Sierra Inc., PMC-980577 – Saturn Compatible Scaleable Bandwidth Interface (SBI) Specification, Issue 3, 1998
- TTC Standard JT-G704 - Frame Structures on Primary and Secondary Hierarchical Digital Interfaces, 1995.
- TTC Standard JT-G706 - Frame Synchronization and CRC Procedure
- TTC Standard JT-I431 - ISDN Primary Rate User-Network Interface Layer 1 - Specification, 1995.
- Nippon Telegraph and Telephone Corporation - Technical Reference for High-Speed Digital Leased Circuit Services, Third Edition, 1990.

## 4 APPLICATION EXAMPLES

Figure 1 - DS3 Multiplexing Application

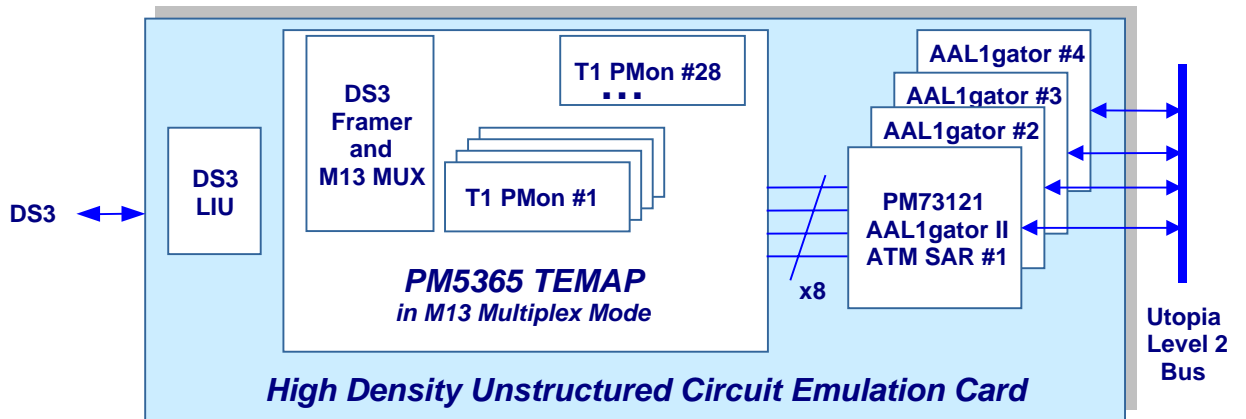
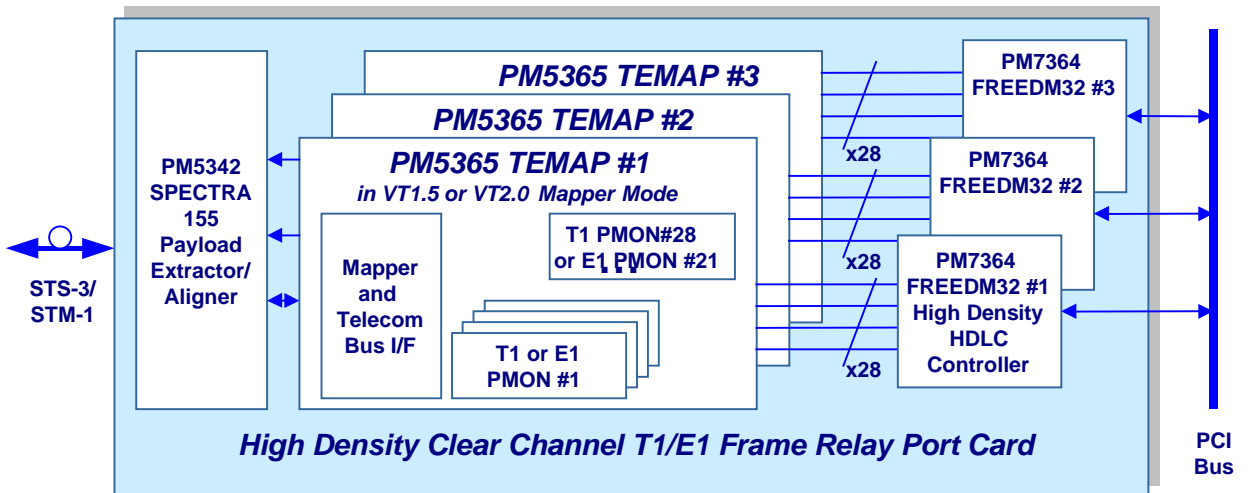


Figure 2 - High Density Frame Relay Application

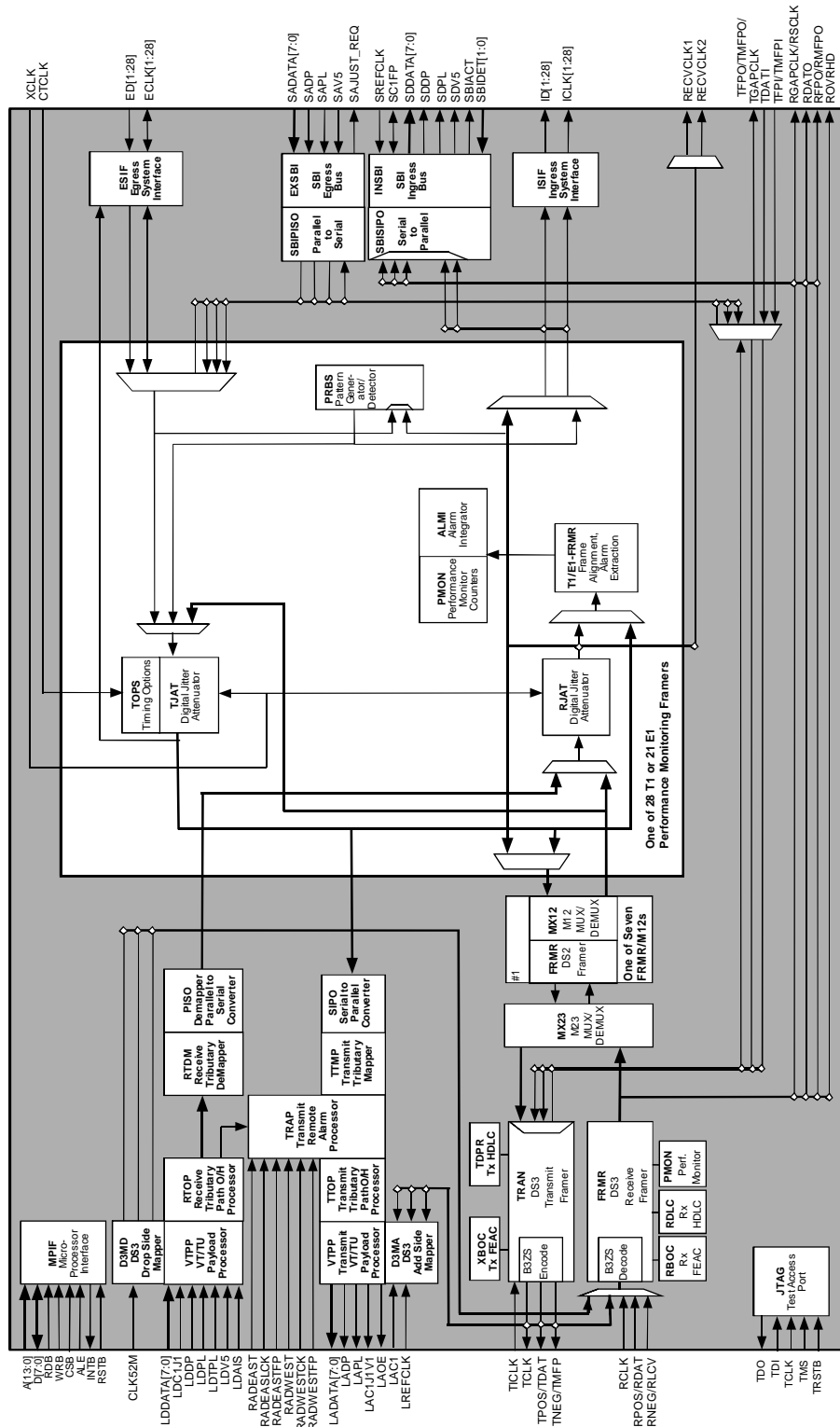


## **5 BLOCK DIAGRAM**

### **5.1 Top Level Block Diagram**

Figure 3 shows the complete TEMAP. Clear channel T1 links can be multiplexed into the DS3 or can be mapped into the telecom bus as SONET VT1.5 virtual tributaries or as SDH TU-11 or TU-12 tributary units, shown at the bottom of the diagram. Clear channel E1 links can be mapped into the telecom bus as SONET VT2 virtual tributaries or as SDH TU-12 tributary units, shown at the bottom of the diagram. System side access to the T1s and E1s is available via serial clock and data or the SBI bus. DS3 line side access is via the clock and data interface for line interface units or DS3 mapped into the SONET/SDH telecom bus. Unchannelized DS3 system side access is available through a serial clock and data interface or the SBI bus, both shown at the top of the diagram.

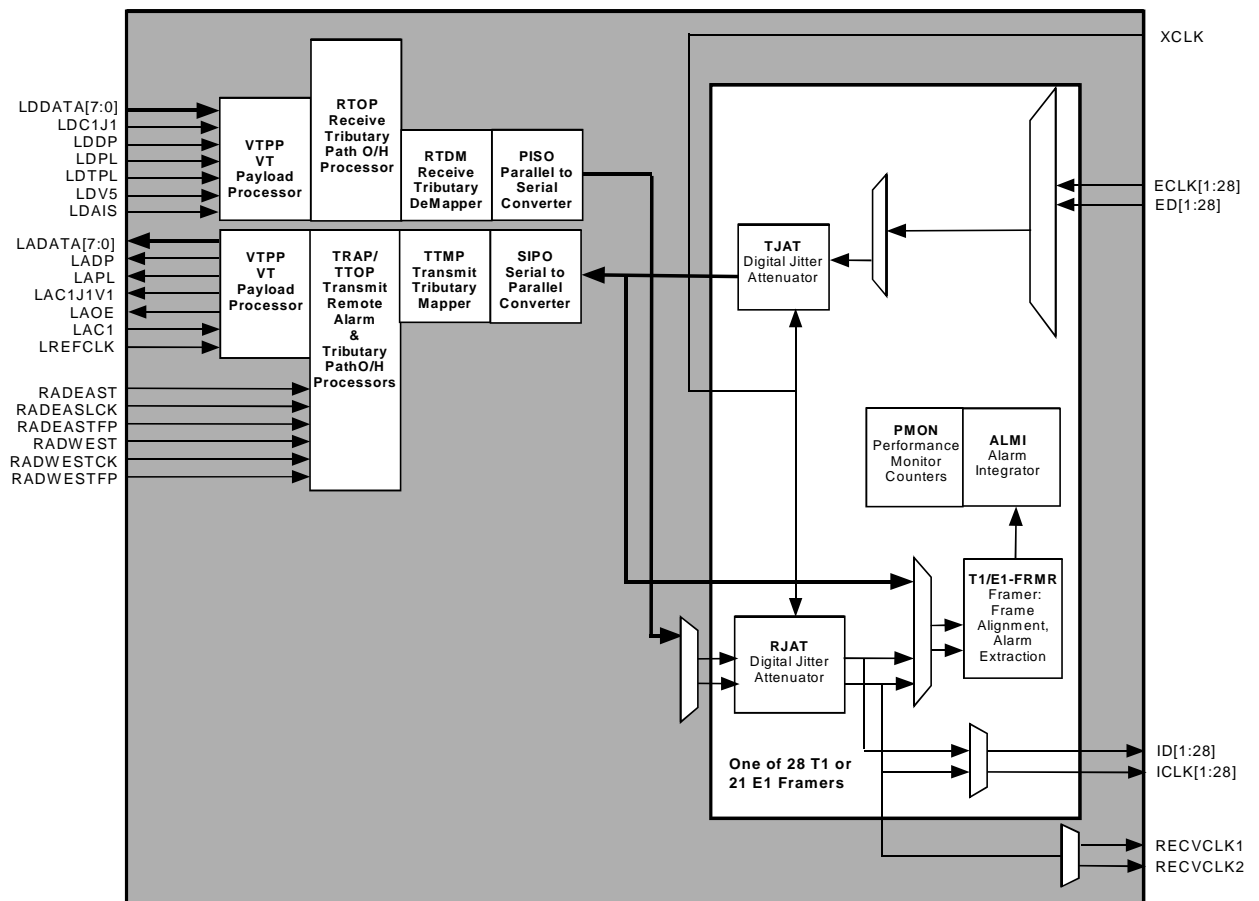
Figure 3 - TEMAP Block Diagram



**5.2 VT/TU Mapper Mode Block Diagram**

Figure 4 shows the TEMAP configured as a VT or TU mapper. In this mode the TEMAP provides access for up to 28 independent unframed 1.544Mb/s streams or 21 independent unframed 2.048Mb/s streams. The 1.544Mb/s and 2.048Mb/s streams can be accessed on the system side as clock and data as shown in Figure 4, or they can be accessed via the SBI bus. The T1 or E1 performance monitoring blocks (PMON blocks) can be used to monitor the passing traffic in either the ingress or egress direction. The M13 Multiplexer mode operates in much the same way as the VT and TU mapper shown in Figure 4.

**Figure 4 - VT/TU Mapper Block Diagram**

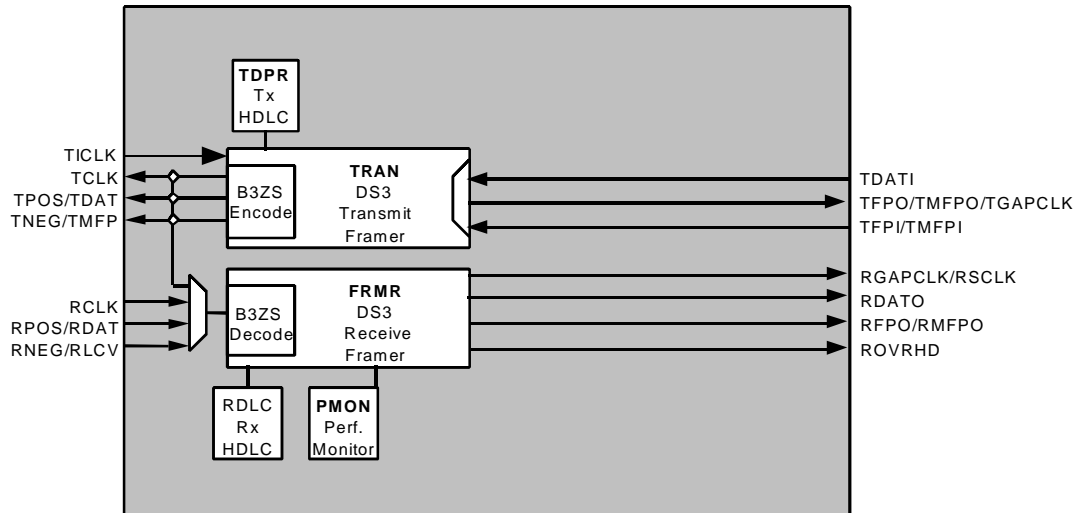


**5.3 DS3 Framer Only Block Diagram**

Figure 5 shows the TEMAP configured as a DS3 framer. In this mode the TEMAP provides access to the full DS3 unchannelized payload. The payload access (right side of diagram) has two clock and data interfacing modes, one

utilizing a gapped clock to mask out the DS3 overhead bits and the second utilizing an ungapped clock with overhead indications on a separate overhead signal. The SBI bus can also be used to provide access to the unchannelized DS3.

**Figure 5 - DS3 Framer Only Mode Block Diagram**



## **6 DESCRIPTION**

The PM5365 VT/TU Mapper and M13 Multiplexer (TEMAP) is a feature-rich device for use in any applications requiring high density link termination over T1 channelized DS3 or T1 and E1 channelized SONET/SDH facilities.

The TEMAP supports asynchronous multiplexing and demultiplexing of 28 DS1s into a DS3 signal as specified by ANSI T1.107 and Bell Communications Research TR-TSY-000009. It supports bit asynchronous mapping and demapping of 28 T1s or 21 E1s into SONET/SDH as specified by ANSI T1.105, Bell Communications Research GR-253-CORE and ITU-T Recommendation G.707. The TEMAP also supports mapping of 21 T1s into SDH via TU-12s. Up to 28 Transparent VT1.5s and TU-11s or 21 Transparent VT2s and TU-12s can be transferred between the SONET/SDH interface and the SBI bus interface.

Performance monitoring in either the ingress or egress direction for up to 28 T1s or 21 E1s in both SONET/SDH VT/TU mapper and M13 multiplexer modes.

Each T1 performance monitor detects and indicates the presence of Yellow and AIS patterns and also integrates Yellow, Red, and AIS alarms. T1 performance monitoring with accumulation of CRC-6 errors, framing bit errors, out-of-frame events, and changes of frame alignment is provided.

Each E1 framer detects and indicates the presence of remote alarm and AIS patterns and also integrates Red and AIS alarms.

The E1 framers support detection of various alarm conditions such as loss of frame, loss of signaling multiframe and loss of CRC multiframe. The E1 framers also support reception of remote alarm signal, remote multiframe alarm signal, alarm indication signal, and time slot 16 alarm indication signal.

E1 performance monitoring with accumulation of CRC-4 errors, far end block errors and framing bit errors is provided.

This device can also be configured as a DS3 framer, providing external access to the full DS3 payload, or a VT/TU mapper, providing access to unframed 1.544Mb/s and 2.048Mb/s links.

PRBS generation or detection is supported on a per T1 or E1 link basis.

The TEMAP can generate a low jitter transmit clock from a variety of clock references, and also provides jitter attenuation in the receive path. Two low jitter recovered T1 clocks can be routed outside the TEMAP for network timing applications.

Serial PCM interfaces to each T1 framer allow 1.544 Mbit/s ingress/egress system interfaces to be directly supported.

A Scaleable Bandwidth Interconnect (SBI) high density byte serial system interface provides higher levels of integration and dense interconnect. The SBI bus interconnects up to 84 T1s or 63 E1. The SBI allows transmit timing to be mastered by either the TEMAP or link layer device connected to the SBI bus. This interconnect allows up to 3 TEMAPs to be connected in parallel to provide the full complement of 84 T1s or 63 E1s of traffic. In addition to clear channel T1s and E1s the TEMAP can transport framed or unframed DS3 links over the SBI bus.

When configured as a DS3 multiplexer/demultiplexer or DS3 framer, the TEMAP accepts and outputs either or both digital B3ZS-encoded bipolar and unipolar signals compatible with M23 and C-bit parity applications.

In the DS3 receive direction, the TEMAP frames to DS3 signals with a maximum average reframe time of 1.5 ms in the presence of  $10^{-3}$  bit error rate and detects line code violations, loss of signal, framing bit errors, parity errors, C-bit parity errors, far end block errors, AIS, far end receive failure and idle code. The DS3 framer is an off-line framer, indicating both out of frame (OOF) and change of frame alignment (COFA) events. The error events (C-BIT, FEBC, etc.) are still indicated while the framer is OOF, based on the previous frame alignment. When in C-bit parity mode, the Path Maintenance Data Link and the Far End Alarm and Control (FEAC) channels are extracted. HDLC receivers are provided for Path Maintenance Data Link support. In addition, valid bit-oriented codes in the FEAC channels are detected and are available through the microprocessor port.

Error event accumulation is also provided by the TEMAP. Framing bit errors, line code violations, excessive zeros occurrences, parity errors, C-bit parity errors, and far end block errors are accumulated. Error accumulation continues even while the off-line framers are indicating OOF. The counters are intended to be polled once per second, and are sized so as not to saturate at a  $10^{-3}$  bit error rate. Transfer of count values to holding registers is initiated through the microprocessor interface.

In the DS3 transmit direction, the TEMAP inserts DS3 framing, X and P bits. When enabled for C-bit parity operation, bit-oriented code transmitters and HDLC transmitters are provided for insertion of the FEAC channels and the Path Maintenance Data Links into the appropriate overhead bits. Alarm Indication Signals, Far End Receive Failure and idle signal can be inserted using either internal registers or can be configured for automatic insertion upon received errors. When M23 operation is selected, the C-bit Parity ID bit (the first C-bit of the first M sub-frame) is forced to toggle so that downstream equipment will not confuse an M23-formatted stream with stuck-at-1 C-bits for C-bit Parity

application. Transmit timing is from an external reference or from the receive direction clock.

The TEMAP also supports diagnostic options which allow it to insert a Pseudo Random Binary Sequence (PRBS) into a DS3 payload and checked in the receive DS3 payload for bit errors. A fixed 100100... pattern is available for insertion directly into the B3ZS encoder for proper pulse mask shape verification.

When configured in DS3 multiplexer mode, seven 6312 kbit/s data streams are demultiplexed and multiplexed into and out of the DS3 signal. Bit stuffing and rate adaptation is performed. The C-bits are set appropriately, with the option of inserting DS2 loopback requests. Interrupts can be generated upon detection of loopback requests in the received DS3. AIS may be inserted in the any of the 6312 kbit/s tributaries in both the multiplex and demultiplex directions. C-bit parity is supported by generating a 6.3062723 MHz clock, which corresponds to a stuffing ratio of 100%.

Framing to the demultiplexed 6312 kbit/s data streams supports DS2 (ANSI T1.107) frame formats. The maximum average reframe time is 7ms for DS2. Far end receive failure is detected and M-bit and F-bit errors are accumulated. The DS2 framer is an off-line framer, indicating both OOF and COFA events. Error events (FERF, MERR, FERR, PERR, RAI, framing word errors) are still indicated while the DS2 framer is indicating OOF, based on the previous alignment.

Each of the seven 6312 kbit/s multiplexers may be independently configured to multiplex and demultiplex four 1544 kbit/s DS1s into and out of a DS2 formatted signal. Tributary frequency deviations are accommodated using internal FIFOs and bit stuffing. The C-bits are set appropriately, with the option of inserting DS1 loopback requests. Interrupts can be generated upon detection of loopback requests in the received DS2. AIS may be inserted in any of the low speed tributaries in both multiplex and demultiplex directions.

When configured as a DS3 framer the unchannelized payload of the DS3 link is available to an external device.

The SONET/SDH line side interface provides STS-1 SPE synchronous payload envelope processing and generation, TUG3 tributary unit group processing and generation within a VC4 virtual container and VC3 virtual container processing and generation. The payload processor aligns and monitors the performance of SONET virtual tributaries (VTs) or SDH tributary units (TUs). Maintenance functions per tributary include detection of loss of pointer, AIS alarm, tributary path signal label mismatch and tributary path signal label unstable alarms. Optionally interrupts can be generated due to the assertion and removal of any of the above alarms. Counts are accumulated for tributary path BIP-2 errors on a block or bit basis and for FEBE indications. The synchronous payload envelope generator generates all tributary pointers and calculates and inserts tributary

path BIP-2. The generator also inserts FEBE, RDI and enhanced RDI in the V5 byte. Software can force AIS insertion on a per tributary basis.

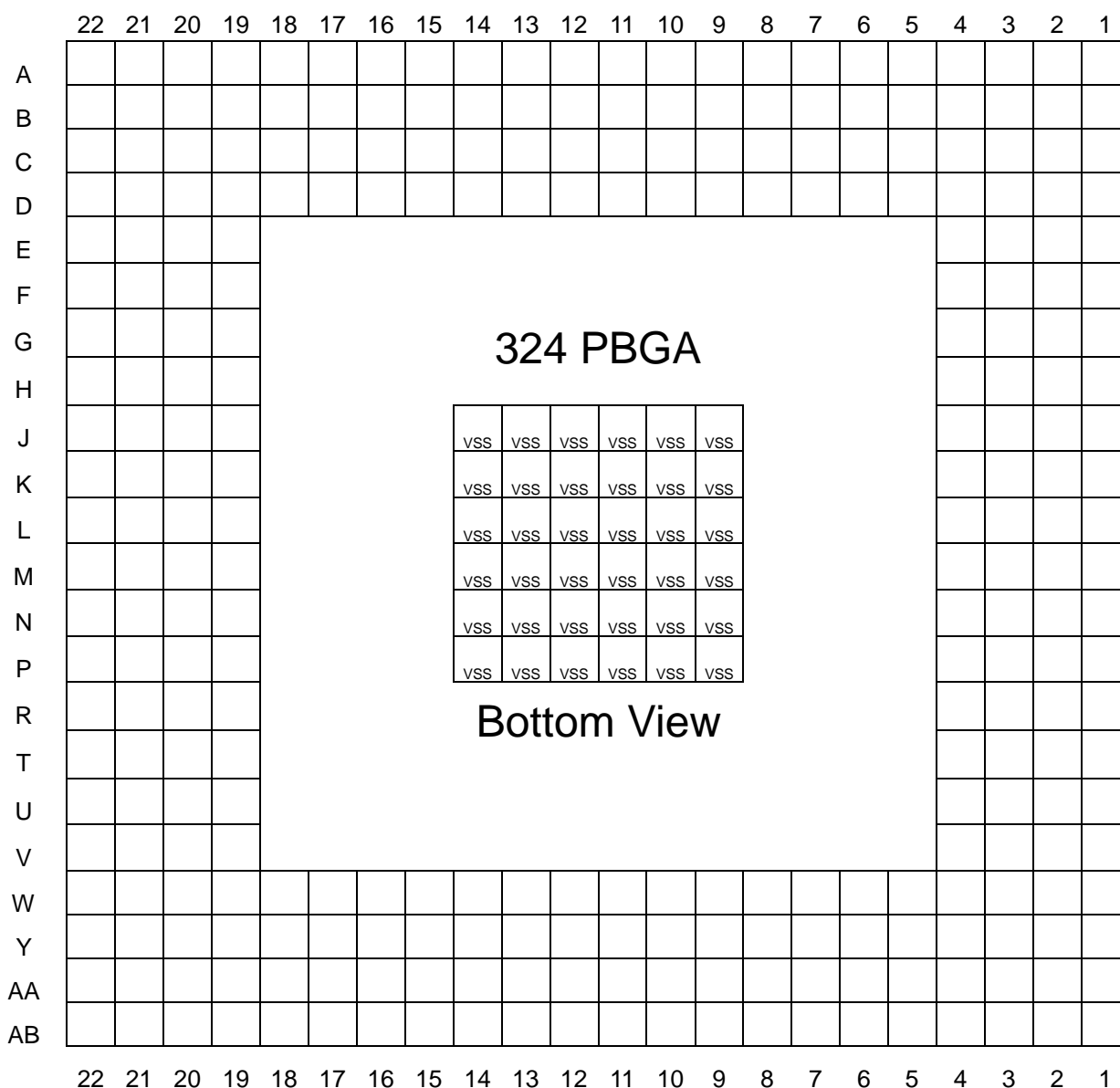
A SONET/SDH mapper maps and demaps up to 28 T1s, 21 E1s or a single DS3 into a STS-1 SPE, TUG3 or VC3 through an elastic store. The fixed stuff (R) bits are all set to zeros or ones under microprocessor control. The bit asynchronous demapper performs majority vote C-bit decoding to detect stuff requests for T1, E1 and DS3 asynchronous mappings. The VT1.5/VT2/TU-11/TU-12 mapper uses an elastic store and a jitter attenuator capability to minimize jitter introduced via bit stuffing.

The TEMAP is configured, controlled and monitored via a generic 8-bit microprocessor bus through which all internal registers are accessed. All sources of interrupts can be masked and acknowledged through the microprocessor interface.

## 7 PIN DIAGRAM

The TEMAP is packaged in a 324-pin PBGA package having a body size of 23mm by 23mm and a ball pitch of 1.0 mm. The center 36 balls are not used as signal I/Os and are thermal balls. Pin names and locations are defined in the Pin Description Table in section 8. Mechanical information for this package is in the section 19.

**Figure 6 - Pin Diagram**



## 8 PIN DESCRIPTION

Pin Name	Type	Pin No.	Function
<b>DS3 Line Side Interface</b>			
RCLK	Input	W5	<b>Receive Input Clock (RCLK).</b> RCLK provides the receive direction timing. RCLK is a DS3, nominally a 44.736 MHz, 50% duty cycle clock input.
RPOS/RDAT	Input	Y7	<p><b>Positive Input Pulse (RPOS).</b> RPOS represents the positive pulses received on the B3ZS-encoded DS3 when dual rail input format is selected.</p> <p><b>Receive Data Input (RDAT).</b> RDAT represents the NRZ (unipolar) DS3 input data stream when single rail input format is selected.</p> <p>RPOS and RDAT are sampled on the rising edge of RCLK by default and may be enabled to be sampled on the falling edge of RCLK by setting the RFALL bit in the DS3 Master Receive Line Options register.</p>
RNEG/RLCV	Input	AB6	<p><b>Negative Input Pulse (RNEG).</b> RNEG represents the negative pulses received on the B3ZS-encoded DS3 when dual rail input format is selected.</p> <p><b>Line code violation (RLCV).</b> RLCV represents receive line code violations when single rail input format is selected.</p> <p>RNEG and RLCV are sampled on the rising edge of RCLK by default and may be enabled to be sampled on the falling edge of RCLK by setting the RFALL bit in the DS3 Master Receive Line Options register.</p>
TCLK	Output	AA7	<b>Transmit Clock (TCLK).</b> TCLK provides timing for circuitry downstream of the DS3 transmitter of the TEMAP. TCLK is nominally a 44.736 MHz, 50% duty cycle clock.

Pin Name	Type	Pin No.	Function
TPOS/TDAT	Output	AB7	<p><b>Transmit Positive Pulse (TPOS).</b> TPOS represents the positive pulses transmitted on the B3ZS-encoded DS3 line when dual-rail output format is selected.</p> <p><b>Transmit Data Output (TDAT).</b> TDAT represents the NRZ (unipolar) DS3 output data stream when single rail output format is selected.</p> <p>TPOS and TDAT are updated on the falling edge of TCLK by default but may be enabled to be updated on the rising edge of TCLK by setting the TRISE bit in the DS3 Master Transmit Line Options register. TPOS and TDAT are updated on TICLK rather than TCLK when the TICLK bit in the DS3 Master Transmit Line Options register is set.</p>
TNEG/TMFP	Output	W6	<p><b>Transmit Negative Pulse (TNEG).</b> TNEG represents the negative pulses transmitted on the B3ZS-encoded DS3 line when dual-rail output format is selected.</p> <p><b>Transmit Multiframe Pulse (TMFP).</b> This signal marks the transmit M-frame alignment when configured for single rail operation. TMFP indicates the position of overhead bits in the transmit transmission system stream, TDAT. TMFP is high during the first bit (X1) of the multiframe.</p> <p>TNEG and TMFP are updated on the falling edge of TCLK by default but may be enabled to be updated on the rising edge of TCLK by setting the TRISE bit in the DS3 Master Transmit Line Options register. TNEG and TMFP are updated on TICLK rather than TCLK when the TICLK bit in the DS3 Master Transmit Line Options register is set.</p>
TICLK	Input	AA6	<p><b>Transmit input clock (TICLK).</b> TICLK provides the transmit direction timing. TICLK is nominally a 44.736 MHz, 50% duty cycle clock.</p> <p>This clock is only required when using the DS3 transmitter, either with the DS3 line side interface or the DS3 mapper. When not used this clock input should be connected to ground.</p>

Pin Name	Type	Pin No.	Function
XCLK/VCLK	Input	E20	<p><b>Crystal Clock Input (XCLK).</b> This 24 times T1 or E1 clock provides timing for many of the T1 and E1 portions of TEMAP. XCLK is nominally a 37.056 MHz <math>\pm</math> 32ppm, 50% duty cycle clock when configured for T1 modes and is nominally a 49.152 MHz <math>\pm</math> 32ppm, 50% duty cycle clock when configured for E1 modes.</p> <p>This clock is required for all operating modes of the TEMAP.</p> <p><b>Test Vector Clock (VCLK).</b> This signal is used during production testing.</p>

Pin Name	Type	Pin No.	Function
<b>DS3 System Side Interface</b>			
RGAPCLK/RSCLK	Output	Y3	<p><b>Framer Recovered Gapped Clock (RGAPCLK).</b> RGAPCLK is valid when the TEMAP is configured as a DS3 framer by setting the OPMODE[1:0] bits in the Global Configuration register and the RXGAPEN bit in the DS3 Master Unchannelized Interface Options register.</p> <p>RGAPCLK is the recovered clock and timing reference for RDATO. RGAPCLK is held either high or low during bit positions which correspond to overhead.</p> <p><b>Framer Recovered Clock (RSCLK).</b> RSCLK is valid when the TEMAP is configured as a DS3 framer by setting the OPMODE[1:0] bits in the Global Configuration register.</p> <p>RSCLK is the recovered clock and timing reference for RDATO, RFPO/RMFPO, and ROVRHD.</p> <p>This signal shares a signal pin with ICLK[1]. When enabled for unchannelized DS3 operation this signal will be RGAPCLK/RSCLK, otherwise it will be ICLK[1].</p>
RDATO	Output	AA5	<p><b>Framer Receive Data (RDATO).</b> RDATO is valid when the TEMAP is configured as a DS3 framer by setting the OPMODE[1:0] bits in the Global Configuration register. RDATO is the received data aligned to RFPO/RMFPO and ROVRHD.</p> <p>RDATO is updated on either the falling or rising edge of RGAPCLK or RSCLK, depending on the value of the RSCLKR bit in the DS3 Master Unchannelized Interface Options register. By default RDATO will be updated on the falling edge of RGAPCLK or RSCLK.</p> <p>This signal shares a signal pin with ID[1] and MVID[1]. This signal will be RDATO only when enabled for unchannelized DS3 operation.</p>

Pin Name	Type	Pin No.	Function
RFPO/RMFPO	Output	AB5	<p><b>Framer Receive Frame Pulse/Multi-frame Pulse (RFPO/RMFPO).</b> RFPO/RMFPO is valid when the TEMAP is configured to be in framer only mode by setting the OPMODE[1:0] bits in the Global Configuration register.</p> <p>RFPO is aligned to RDATO and indicates the position of the first bit in each DS3 M-subframe.</p> <p>RMFPO is aligned to RDATO and indicates the position of the first bit in each DS3 M-frame. This is selected by setting the RXMFPO bit in the Master Framer Configuration Registers.</p> <p>RFPO/RMFPO is updated on either the falling or rising edge of RSCLK depending on the setting of the RSCLKR bit in the DS3 Master Unchannelized Interface Options register.</p> <p>This signal shares a signal pin with IFP[1]. When enabled for unchannelized DS3 operation this signal will be RFPO/RMFPO, otherwise it will be IFP[1].</p>
ROVRHD	Output	Y6	<p><b>Framer Receive Overhead (ROVRHD).</b> ROVRHD is valid when the TEMAP is configured as a DS3 framer by setting the OPMODE[1:0] bits in the Global Configuration register.</p> <p>ROVRHD will be high whenever the data on RDATO corresponds to an overhead bit position. ROVRHD is updated on the either the falling or rising edge of RSCLK depending on the setting of the RSCLKR bit in the DS3 Master Unchannelized Interface Options register.</p> <p>This signal shares a signal pin with ID[2] and CASID[1]. This signal will be ROVRHD only when enabled for unchannelized DS3 operation.</p>

Pin Name	Type	Pin No.	Function
TFPO/TMFPO/ TGAPCLK	Output	AB3	<p><b>Framer Transmit Frame Pulse/Multi-frame Pulse Reference (TFPO/TMFPO).</b> TFPO/TMFPO is valid when the TEMAP is configured as a DS3 framer by setting the OPMODE[1:0] bits in the Global Configuration register and setting the TXGAPEN bit to 0 in the DS3 Master Unchannelized Interface Options register.</p> <p>TFPO pulses high for 1 out of every 85 clock cycles, giving a reference M-subframe indication.</p> <p>TMFPO pulses high for 1 out of every 4760 clock cycles, giving a reference M-frame indication.</p> <p>TFPO/TMFPO is updated on the falling edge of TCLK. TFPO/TMFPO can be configured to be updated on the rising edge of TCLK by setting the TDATAIFALL bit to 1 in the DS3 Master Unchannelized Interface Options register.</p> <p><b>Framer Gapped Transmit Clock (TGAPCLK).</b> TGAPCLK is valid when the TEMAP is configured as a DS3 framer by setting the OPMODE[1:0] bits in the Global Configuration register and setting the TXGAPEN bit to 1 in the DS3 Master Unchannelized Interface Options register.</p> <p>TGAPCLK is derived from the transmit reference clock TCLK or from the receive clock if loop-timed. The overhead bit (gapped) positions are generated internal to the device. TGAPCLK is held high during the overhead bit positions. This clock is useful for interfacing to devices which source payload data only.</p> <p>TGAPCLK is used to sample TDATAI.</p> <p>This signal shares a signal pin with ECLK[1]. When enabled for unchannelized DS3 operation this signal will be TFPO/TMFPO/TGAPCLK, otherwise it will be ECLK[1].</p>

Pin Name	Type	Pin No.	Function
TDATI	Input	AB4	<p><b>Framer Transmit Data (TDATI).</b> TDATI contains the serial data to be transmitted when the TEMAP is configured as a DS3 framer by setting the OPMODE[1:0] bits in the Global Configuration register. TDATI is sampled on the rising edge of TICLK if the TXGAPEN bit in the DS3 Master Unchannelized Interface Options register is logic 0. If TXGAPEN is logic 1, then TDATI is sampled on the rising edge of TGAPCLK. TDATI can be configured to be sampled on the falling edge of TICLK or TGAPCLK by setting the TDATIFALL bit in the DS3 Master Unchannelized Interface Options register.</p> <p>This signal shares a signal pin with ED[1] and MVED[1]. This signal will be TDATI only when enabled for unchannelized DS3 operation.</p>
TFPI/TMFPI	Input	AA3	<p><b>Framer Transmit Frame Pulse/Multiframe Pulse (TFPI/TMFPI).</b> TFPI/TMFPI is valid when the TEMAP is configured as a DS3 framer by setting the OPMODE[1:0] bits in the Global Configuration register.</p> <p>TFPI indicates the position of all overhead bits in each DS3 M-subframe. TFPI is not required to pulse at every frame boundary.</p> <p>TMFPI indicates the position of the first bit in each DS3 M-frame. TMFPI is not required to pulse at every multiframe boundary.</p> <p>TFPI/TMFPI is sampled on the rising edge of TICLK if the TXGAPEN bit in the DS3 Master Unchannelized Interface Options register is logic 0. If TXGAPEN is logic 1, then TFPI/TMFPI is sampled on the rising edge of TGAPCLK. TFPI/TMFPI can be configured to be sampled on the falling edge of TICLK or TGAPCLK by setting the TDATIFALL bit to 1 in the DS3 Master Unchannelized Interface Options register.</p> <p>This signal shares a signal pin with ED[2] and CASED[1]. This signal will be TFPI/TMFPI only when enabled for unchannelized DS3 operation.</p>

Pin Name	Type	Pin No.	Function
<b>T1 and E1 System Side Serial Clock and Data Interface</b>			
ICLK[1]	Output	Y3	<b>Ingress Clocks (ICLK[1:28]).</b> Each ingress clock is optionally a smoothed (jitter attenuated) version of the associated receive clock from either the SONET/SDH mapper or the DS3 multiplexer. ID[x] signals are updated on the active edge of ICLK[x]. In E1 mode only ICLK[1:21] are used. ICLK[1] shares a pin with the DS3 system interface signal RGAPCLK/RSCLK.
ICLK[2]		AB2	
ICLK[3]		AB20	
ICLK[4]		AB21	
ICLK[5]		W22	
ICLK[6]		Y20	
ICLK[7]		H22	
ICLK[8]		F19	
ICLK[9]		W3	
ICLK[10]		AA1	
ICLK[11]		H3	
ICLK[12]		H1	
ICLK[13]		L22	
ICLK[14]		K19	
ICLK[15]		F22	
ICLK[16]		G20	
ICLK[17]		T3	
ICLK[18]		U1	
ICLK[19]		D1	
ICLK[20]		C1	
ICLK[21]		H19	
ICLK[22]		G19	
ICLK[23]		E19	
ICLK[24]		F21	
ICLK[25]		K3	
ICLK[26]		J4	
ICLK[27]		E3	
ICLK[28]		D2	

Pin Name	Type	Pin No.	Function
ID[1] ID[2] ID[3] ID[4] ID[5] ID[6] ID[7] ID[8] ID[9] ID[10] ID[11] ID[12] ID[13] ID[14] ID[15] ID[16] ID[17] ID[18] ID[19] ID[20] ID[21] ID[22] ID[23] ID[24] ID[25] ID[26] ID[27] ID[28]	Output	AA5 Y6 AA20 T19 R19 P20 G22 G21 Y2 W2 G4 H2 P21 P22 A12 D12 U2 V4 D11 A11 M19 L19 D10 A10 J1 H4 B10 C10	<p><b>Ingress Data (ID[1:28]).</b> Each ID[x] signal contains the recovered data stream.</p> <p>ID[x] is aligned to the receive line timing and is updated on the active edge of the associated ICLK[x].</p> <p>In E1 mode only ID[1:21] are used.</p> <p>ID[1] shares a pin with the DS3 system interface signal RDATO. ID[2] shares a pin with the DS3 system interface signal ROVRHD. ID[15,16,19,20,23,24,27,28] shares pins with the SBI interface bus SDDATA[7:0].</p>

Pin Name	Type	Pin No.	Function
CTCLK	Input	M3	<p><b>Common Transmit Clock (CTCLK).</b> This input signal is used as a reference transmit tributary clock which can be used in egress Clock Master: Clear Channel mode. Depending on the configuration of the TEMAP, CTCLK may be a line rate clock (so the transmit clock is generated directly from CTCLK, or from CTCLK after jitter attenuation) or a multiple of 8kHz (<math>N \times 8\text{kHz}</math>, where <math>1 \leq N \leq 256</math>) so long as CTCLK is jitter-free when divided down to 8kHz (in which case the transmit clock is derived by the DJAT PLL using CTCLK as a reference).</p> <p>The TEMAP may be configured to ignore the CTCLK input and utilize CECLK or one of the recovered Ingress clocks instead, RECVCLK1 and RECVCLK2. Receive tributary clock[x] is automatically substituted for CTCLK if line loopback is enabled.</p>

Pin Name	Type	Pin No.	Function
ED[1]	Input	AB4	<p><b>Egress Data (ED[1:28]).</b> The egress data streams to be transmitted are input on these pins. When the Clock Master: Clear Channel mode is active, ED[x] is sampled on the active edge of ECLK[x]. When Clock Slave: Clear channel mode is active, ED[x] is also sampled on the active edge of ECLK[x].</p> <p>In E1 mode only ED[1:21] are used.</p> <p>ED[1] shares a pin with the DS3 system interface signal TDATI. ED[2] shares a pin with the DS3 system interface signal TFPI/TMFPI.</p> <p>ED[7,8,11,12,15,16,19,20,23,24,27,28] shares pins with the SBI interface add bus signals.</p>
ED[2]		AA3	
ED[3]		P19	
ED[4]		N20	
ED[5]		N21	
ED[6]		N22	
ED[7]		A7	
ED[8]		A2	
ED[9]		T2	
ED[10]		R4	
ED[11]		A3	
ED[12]		B4	
ED[13]		N19	
ED[14]		M22	
ED[15]		D6	
ED[16]		C7	
ED[17]		P2	
ED[18]		M1	
ED[19]		D4	
ED[20]		B6	
ED[21]		C20	
ED[22]		E22	
ED[23]		A5	
ED[24]		B5	
ED[25]		L1	
ED[26]		L2	
ED[27]		A4	
ED[28]		C5	

Pin Name	Type	Pin No.	Function
ECLK[1] ECLK[2] ECLK[3] ECLK[4] ECLK[5] ECLK[6] ECLK[7] ECLK[8] ECLK[9] ECLK[10] ECLK[11] ECLK[12] ECLK[13] ECLK[14] ECLK[15] ECLK[16] ECLK[17] ECLK[18] ECLK[19] ECLK[20] ECLK[21] ECLK[22] ECLK[23] ECLK[24] ECLK[25] ECLK[26] ECLK[27] ECLK[28]	I/O	AB3 Y4 Y19 AA21 AB22 V22 T21 T22 AB1 T1 G2 G3 U21 V19 D21 C21 U4 R1 D3 F1 T20 U22 B22 D20 L3 K4 E4 F2	<p><b>Egress Clock (ECLK[1:28]).</b> When Clock Master: Clear Channel mode is active, ECLK[x] is an output and is used to sample the associated egress data, ED[x]. ECLK[x] is a version of the transmit clock[x] which is generated from the receive clock or the common transmit clock, CTCLK.</p> <p>When in Clock Slave: Clear Channel mode this input is an input and is used to sampled ED[x].</p> <p>ED[x] is sampled on the active edge of the associated ECLK[x].</p> <p>ECLK[1] shares a pin with the DS3 system interface output signal TFPO/TMFPO/TGAPCLK.</p>
<b>Recovered T1 and E1 Clocks</b>			
RECVCLK1	Output	D22	<b>Recovered Clock 1 (RECVCLK1).</b> This clock output is a recovered and de-jittered clock from any one of the 28 T1 or 21 E1 streams.
RECVCLK2	Output	C22	<b>Recovered Clock 2 (RECVCLK2).</b> This clock output is a recovered and de-jittered clock from any one of the 28 T1 or 21 E1 streams.
<b>Telecom Line Side Interface</b>			

Pin Name	Type	Pin No.	Function
LREFCLK	Input	W12	<p><b>Line Reference Clock (LREFCLK).</b> This signal provides reference timing for the SONET telecom bus interface. On the incoming byte interface of the telecom bus, LDC1J1V1, LDDATA[7:0], LDDP, LDPL, LDTPL, LDV5, LDAIS and LAC1 are sampled of the rising edge of LREFCLK. In the outgoing byte interface, LADATA[7:0], LADP, LAPL, LAC1J1V1 and LAOE are updated on the rising edge of LREFCLK.</p> <p>This clock is nominally a 19.44MHz +/-50ppm clock with a 50% duty cycle. This clock can be external connected to SREFCLK. When in Transparent VT mode this clock must be connected to SREFCLK.</p>
LAC1	Input	W13	<p><b>Line Add C1 Frame Pulse (LAC1).</b> The Add bus timing signal identifies the frame and multiframe boundaries on the Add Data bus LADATA[7:0].</p> <p>LAC1 is set high to mark the first C1 byte of the first transport envelope frame of the 4 frame multiframe on the LADATA[7:0] bus. LAC1 need not be presented on every occurrence of the multiframe .</p> <p>LAC1 is sampled on the rising edge of LREFCLK.</p>

Pin Name	Type	Pin No.	Function
LAC1J1V1	Output	AA11	<p><b>Line Add Bus Composite Timing Signal (LAC1J1V1).</b> The Add bus composite timing signal identifies the frame, payload and tributary multiframe boundaries on the Line Add Data bus LADATA[7:0]. LAC1J1V1 pulses high with the Line Add Payload Active signal LAPL set low to mark the first STS-1 (STM-0/AU3) identification byte or equivalently the STM identification byte C1. Optionally the LAC1J1V1 signal pulses high with LAPL set high to mark the path trace byte J1. Optionally the LAC1J1V1 signal pulses high on the V1 byte to indicate tributary multiframe boundaries.</p> <p>In a system with multiple TEMAPs sharing the same Line Add bus only one device should have LAC1J1V1 connected. All devices must be configured via the LOCK0 bits in the Master SONET/SDH Configuration and TTMP Telecom Interface Configuration registers for the same J1 location corresponding to a pointer offset of 0 or 522.</p> <p>LAC1J1V1 is updated on the rising edge of LREFCLK.</p>
LAOE	Output	AB11	<p><b>Line Add Bus Output Enable (LAOE).</b> The Add Bus output enable signal is asserted high whenever the Line Add Bus is being driven which is co-coincident with the Line Add bus outputs coming out of tri-state.</p> <p>This pin is intended to control an external multiplexer if an external multiplexer is used to merge multiple TEMAPs onto the telecom Add bus. This same function is accomplished with the Add bus tristate drivers but increased tolerance to tributary configuration problems in the form of bus contention is possible with an external mux. This output is controlled via the LAOE bit in the TTMP Tributary Control registers.</p> <p>LAOE is updated on the rising edge of LREFCLK.</p>

Pin Name	Type	Pin No.	Function
LADATA[0] LADATA[1] LADATA[2] LADATA[3] LADATA[4] LADATA[5] LADATA[6] LADATA[7]	Output Tristate	AB8 W7 W8 AB9 W9 Y10 AA10 AB10	<p><b>Line Add Bus Data (LADATA[7:0]).</b> The add bus data contains the SONET transmit payload data in byte serial format. All transport overhead bytes are set to 00h. The phase relation of the SPE (VC) to the transport frame is determined by the Add Bus composite timing signal LAC1J1V1 and is SW selectable to be either 0 or 522. LADATA[7] is the most significant bit (corresponding to bit 1 of each serial word, the first bit to be transmitted).</p> <p>LADATA[7:0] is only asserted during the SONET/SDH tributaries assigned to this device as determined by the LAOE bit in the TTMP Tributary Control registers.</p> <p>LADATA[7:0] is updated on the rising edge of LREFCLK.</p>
LADP	Output Tristate	W10	<p><b>Line Add Bus Data Parity (LADP).</b> The Add Bus data parity signal carries the parity of the outgoing signals. The parity calculation encompasses the LADATA[7:0] bus and optionally the LAC1J1V1 and LAPL signals. LAC1J1V1 and LAPL can be included in the parity calculation by setting the INCLAC1J1V1 and INCLAPL register bits in the Master SONET/SDH Egress Configuration register high, respectively. Odd parity is selected by setting the LAOP register bit in the same register high and even parity is selected by setting the LAOP bit low.</p> <p>LADP is only asserted during the SONET/SDH tributaries assigned to this device as determined by the LAOE bit in the TTMP Tributary Control registers.</p> <p>LADP is updated on the rising edge of LREFCLK.</p>
LAPL	Output Tristate	Y11	<p><b>Line Add Bus Payload Active (LAPL).</b> The Add Bus payload active signal identifies the payload bytes on LADATA[7:0]. LAPL is set high during path overhead and payload bytes and low during transport overhead bytes.</p> <p>LAPL is only asserted during the SONET/SDH tributaries assigned to this device as determined by the LAOE bit in the TTMP Tributary Control registers.</p> <p>LAPL is updated on the rising edge of LREFCLK.</p>

Pin Name	Type	Pin No.	Function
LDDATA[0] LDDATA[1] LDDATA[2] LDDATA[3] LDDATA[4] LDDATA[5] LDDATA[6] LDDATA[7]	Input	AA13 Y13 W14 AB14 W15 W16 AB15 W17	<b>Line Drop Bus Data (LDDATA[7:0]).</b> The drop bus data contains the SONET/SDH receive payload data in byte serial format. LDDATA[7] is the most significant bit, corresponding to bit 1 of each serial word, the bit transmitted first.  LDDATA[7:0] is sampled on the rising edge of LREFCLK.
LDDP	Input	AB16	<b>Line Drop Bus Data Parity (LDDP).</b> The incoming data parity signal carries the parity of the incoming signals. The parity calculation encompasses the LDDATA[7:0] bus and optionally the LDC1J1V1 and LDPL signals. LDC1J1V1 and LDPL can be included in the parity calculation by setting the INCLDC1J1V1 and INCLDPL bits in the Master SONET/SDH Ingress Configuration register high, respectively. Odd parity is selected by setting the LDOP bit in the Master SONET/SDH Ingress Configuration register high and even parity is selected by setting the LDOP bit low.  LDDP is sampled on the rising edge of LREFCLK.
LDC1J1V1	Input	Y16	<b>Line Drop C1/J1 Frame Pulse (LDC1J1V1).</b> The input C1/J1/V1 frame pulse identifies the transport envelope, synchronous payload envelope frame boundaries and optionally multiframe alignment on the incoming SONET stream.  LDC1J1V1 is set high while LDPL is low to mark the first C1 byte of the transport envelope frame on the LDDATA[7:0] bus. LDC1J1V1 is set high while LDPL is high to mark each J1 byte of the synchronous payload envelope(s) on the LDDATA[7:0] bus. LDC1J1V1 must be present at every occurrence of the first C1 and all J1 bytes.  Optionally LDC1J1V1 indicates multiframe alignment when high during the first V1 bytes of each envelope.  LDC1J1V1 is sampled on the rising edge of LREFCLK.

Pin Name	Type	Pin No.	Function
LDPL	Input	AA16	<p><b>Line Drop Bus Payload Active (LDPL).</b> The payload active signal identifies the bytes on LDDATA[7:0] that carry payload bytes.</p> <p>LDPL is set high during path overhead and payload bytes and low during transport overhead bytes. LDPL is set high during the H3 byte to indicate a negative pointer justification and low during the byte following H3 to indicate a positive pointer justification event.</p> <p>LDPL is sampled on the rising edge of LREFCLK.</p>
LDV5	Input	AB17	<p><b>Line Drop Bus V5 Byte (LDV5).</b> The incoming tributary V5 byte signal marks the various tributary V5 bytes. LDV5 marks each tributary V5 byte on the LDDATA[7:0] bus when high.</p> <p>LDV5 is sampled on the rising edge of LREFCLK.</p>
LDTPL	Input	AB13	<p><b>Line Drop Bus Tributary Payload Active (LDTPL).</b> The tributary payload active signal marks the bytes carrying the tributary payload which have been identified by an external payload processor. When this signal is available, the internal pointer processor can be bypassed.</p> <p>LDTPL is high during each tributary payload byte on the LDDATA[7:0] bus. In floating mode, LDTPL contains valid data only for bytes in the VC3 or VC4 virtual containers, or the STS-1 SPE. It should be ignored for bytes in the transport overhead. In locked mode, LDTPL is low for transport overhead.</p> <p>LDTPL is sampled on the rising edge of LREFCLK.</p>
LDAIS	Input	AB12	<p><b>Line Drop Bus Tributary Path Alarm Indication Signal (LDAIS).</b> The active high tributary path alarm indication signal identifies tributaries on the incoming data stream LDDATA[7:0] that are in AIS state. When this signal is available, the internal pointer processor can be bypassed. LDAIS is invalid when LDTPL is low.</p> <p>LDAIS is sampled on the rising edge of LREFCLK.</p>

Pin Name	Type	Pin No.	Function
RADEASTCK	Input	AA17	<b>Remote Alarm Port East Clock (RADEASTCK).</b> The remote serial alarm port east clock provides timing for the east remote serial alarm port. It is nominally a 9.72 MHz clock, but can range from 1.344 MHz to 10 MHz. Inputs RADEASTFP and RADEAST are sampled on the rising edge of RADEASTCK.
RADEASTFP	Input	AB18	<b>Remote Alarm Port East Frame Pulse (RADEASTFP).</b> The remote serial alarm port east frame pulse is used to locate the alarm bits of the individual tributaries in the east remote serial alarm port. RADEASTFP is set high to mark the first BIP-2 error bit of tributary TU #1 in TUG2 #1 of TUG3 #1 carried in RADEAST. RADEASTFP must be set high to mark every occurrence of this bit. TEMAP will not flywheel on RADEASTFP in order to accommodate a variety of RADEASTCK frequencies. RADEASTFP is sampled on the rising edge of RADEASTCK.
RADEAST	Input	W18	<b>Remote Alarm Port Data East (RADEAST).</b> The remote serial alarm port east carries the tributary path BIP-2 error count, RDI status, and RFI status in the east remote serial alarm port. The first BIP-2 error bit of tributary TU #1 in TUG2 #1 of TUG3 #1 on RADEAST is marked by a high level on RADEASTFP. The status carried on RADEAST is software selectable to be reported on the RDI, RFI and REI outputs and is selectable to be associated with any tributary on the outgoing data stream LADATA[7:0]. RADEAST is sampled on the rising edge of RADEASTCK.
RADWESTCK	Input	AA18	<b>Remote Alarm Port West Clock (RADWESTCK).</b> The remote serial alarm port west clock provides timing for the west remote serial alarm port. It is nominally a 9.72 MHz clock, but can range from 1.344 MHz to 10 MHz. Inputs RADWESTFP and RADWEST are sampled on the rising edge of RADWESTCK.

Pin Name	Type	Pin No.	Function
RADWESTFP	Input	AB19	<p><b>Remote Alarm Port West Frame Pulse (RADWESTFP).</b> The remote serial alarm port west frame pulse is used to locate the alarm bits of the individual tributaries in the west remote serial alarm port. RADWESTFP is set high to mark the first BIP-2 error bit of tributary TU #1 in TUG2 #1 of TUG3 #1 carried in RADWEST. RADWESTFP must be set high to mark every occurrence of this bit. TEMAP will not flywheel on RADWESTFP in order to accommodate a variety of RADWESTCK frequencies.</p> <p>RADWESTFP is sampled on the rising edge of RADWESTCK.</p>
RADWEST	Input	W19	<p><b>Remote Alarm Port Data West (RADWEST).</b> The remote serial alarm port west carries the tributary path BIP-2 error count, RDI status, and RFI status in the west remote serial alarm port. The first BIP-2 error bit of tributary TU #1 in TUG2 #1 of TUG3 #1 on RADWEST is marked by a high level on RADWESTFP. The status carried on RADWEST is software selectable to be reported on the RDI, RFI and REI outputs and is selectable to be associated with any tributary on the outgoing data stream LADATA[7:0].</p> <p>RADWESTFP is sampled on the rising edge of RADWESTCK.</p>
CLK52M	Input	P3	<p><b>52MHz Clock Reference (CLK52M).</b> The 52Mhz clock reference is used to generate a gapped DS3 clock when demapping a DS3 from the SONET stream and also to generate a gapped DS3 clock when receiving a DS3 from the SBI bus interface. This clock has two nominal values.</p> <p>The first is a nominal 51.84MHz 50% duty cycle clock. The second is a nominal 44.928MHz 50% duty cycle clock.</p> <p>When this clock is not used this input must be connected to ground.</p>
<b>Scaleable Bandwidth Interconnect Interface</b>			

Pin Name	Type	Pin No.	Function
SREFCLK	Input	B7	<p><b>System Reference Clock (SREFCLK).</b> This system reference clock is a nominal 19.44MHz +/-50ppm 50% duty cycle clock. This clock is common to both the add and drop sides of the SBI bus.</p> <p>When passing transparent virtual tributaries between the telecom bus and the SBI bus, SREFCLK must be the same as LREFCLK.</p>
SC1FP	I/O	A6	<p><b>System C1 Frame Pulse (SC1FP).</b> The System C1 frame pulse synchronizes devices interfacing to the SBI bus. The frame pulse indicates SBI bus multiframe alignment which occurs every 500uS, therefore this signal is pulsed every 9720 SREFCLKs. This signal does not need to occur every SBI multiframe and can occur at multiples of the SBI multiframe.</p> <p>The TEMAP can be configured to generate this frame pulse. Only one device on the SBI bus should generate this signal. By default this signal is not enabled to generate the frame pulse.</p> <p>The system frame pulse is a single SREFCLK signal long and is updated on the rising edge of SREFCLK.</p>
SADATA[0] SADATA[1] SADATA[2] SADATA[3] SADATA[4] SADATA[5] SADATA[6] SADATA[7]	Input	D6 C7 D4 B6 A5 B5 A4 C5	<p><b>System Add Bus Data (SADATA[7:0]).</b> The System add data bus is a time division multiplexed bus which carries the T1 and DS3 tributary data in byte serial format over the SBI bus structure. This device only monitors the add data bus during the timeslots assigned to this device.</p> <p>SADATA[7:0] is sampled on the rising edge of SREFCLK.</p> <p>This bus shares pins with ED[15,16,19,20,23,24,27,28].</p>
SADP	Input	A2	<p><b>System Add Bus Data Parity (SADP).</b> The system add bus signal carries the even or odd parity for the add bus signals SADATA[7:0], SAPL and SAV5. The TEMAP only monitors the add bus parity during the timeslots assigned to this device.</p> <p>SADP is sampled on the rising edge of SREFCLK.</p> <p>This signal shares a pin with signal ED[8].</p>

Pin Name	Type	Pin No.	Function
SAPL	Input	B4	<p><b>System Add Bus Payload Active (SAPL).</b> The add bus payload active signal indicates valid data within the SBI bus structure. This signal must be high during all octets making up a tributary. This signal goes high during the V3 or H3 octet of a tributary to indicate negative timing adjustments between the tributary rate and the fixed SBI bus structure. This signal goes low during the octet after the V3 or H3 octet of a tributary to indicate positive timing adjustments between the tributary rate and the fixed SBI bus structure.</p> <p>The TEMAP only monitors the add bus payload active signal during the tributary timeslots assigned to this device.</p> <p>SAPL is sampled on the rising edge of SREFCLK.</p> <p>This signal shares a pin with signal ED[12].</p>
SAV5	Input	A3	<p><b>System Add Bus Payload Indicator (SAV5).</b> The add bus payload indicator locates the position of the floating payloads for each tributary within the SBI bus structure. Timing differences between the tributary timing and the synchronous SBI bus are indicated by adjustments of this payload indicator relative to the fixed SBI bus structure.</p> <p>All timing adjustments indicated by this signal must be accompanied by appropriate adjustments in the SAPL signal.</p> <p>The TEMAP only monitors the add bus payload Indicator signal during the tributary timeslots assigned to this device.</p> <p>SAV5 is sampled on the rising edge of SREFCLK.</p> <p>This signal shares a pin with signal ED[11].</p>

Pin Name	Type	Pin No.	Function
SAJUST_REQ	Output Tristate	D7	<p><b>System Add Bus Justification Request (SAJUST_REQ).</b> The justification request signals the Link Layer device to speed up, slow down or maintain the rate which it is sending data to the TEMAP. This is only used when the TEMAP is the timing master for the tributary transmit direction.</p> <p>This active high signal indicates negative timing adjustments when asserted high during the V3 or H3 octet of the tributary. In response to this the Link Layer device sends an extra byte in the V3 or H3 octet of the next SBI bus multi-frame.</p> <p>Positive timing adjustments are requested by asserting justification request high during the octet following the V3 or H3 octet. The Link Layer device responds to this request by not sending an octet during the V3 or H3 octet of the next multi-frame.</p> <p>The TEMAP only drives the justification request signal during the tributary timeslots assigned to this device.</p> <p>SAJUST_REQ is updated on the rising edge of SREFCLK.</p>
SDDATA[0] SDDATA[1] SDDATA[2] SDDATA[3] SDDATA[4] SDDATA[5] SDDATA[6] SDDATA[7]	Output Tristate	A12 D12 D11 A11 D10 A10 B10 C10	<p><b>System Drop Bus Data (SDDATA[7:0]).</b> The System drop data bus is a time division multiplexed bus which carries the T1 and DS3 tributary data in byte serial format over the SBI bus structure. This device only drives the data bus during the timeslots assigned to this device.</p> <p>SDDATA[7:0] is updated on the rising edge of SREFCLK.</p> <p>This bus shares pins with ID[15,16,19,20,23,24,27,28].</p>
SDDP	Output Tristate	D9	<p><b>System Drop Bus Data Parity (SDDP).</b> The system drop bus signal carries the even or odd parity for the drop bus signals SDDATA[7:0], SDPL and SDV5. The TEMAP only drives the data bus parity during the timeslots assigned to this device.</p> <p>SDDP is updated on the rising edge of SREFCLK.</p>

Pin Name	Type	Pin No.	Function
SDPL	Output Tristate	D8	<p><b>System Drop Bus Payload Active (SDPB).</b> The payload active signal indicates valid data within the SBI bus structure. This signal is asserted during all octets making up a tributary. This signal goes high during the V3 or H3 octet of a tributary to accommodate negative timing adjustments between the tributary rate and the fixed SBI bus structure. This signal goes low during the octet after the V3 or H3 octet of a tributary to accommodate positive timing adjustments between the tributary rate and the fixed SBI bus structure.</p> <p>The TEMAP only drives the payload active signal during the tributary timeslots assigned to this device. SDPL is updated on the rising edge of SREFCLK.</p>
SDV5	Output Tristate	A9	<p><b>System Drop Bus Payload Indicator (SDV5).</b> The payload indicator locates the position of the floating payloads for each tributary within the SBI bus structure. Timing differences between the tributary timing and the synchronous SBI bus are indicated by adjustments of this payload indicator relative to the fixed SBI bus structure.</p> <p>All timing adjustments indicated by this signal are accompanied by appropriate adjustments in the SDPL signal.</p> <p>The TEMAP only drives the payload Indicator signal during the tributary timeslots assigned to this device. SDV5 is updated on the rising edge of SREFCLK.</p>
SBIACT	Output	A8	<p><b>SBI Output Active (SBIACT).</b> The SBI Output Active indicator is high whenever the TEMAP is driving the SBI drop bus signals. This signal is used by other TEMAPs or other SBI devices to detect SBI configuration problems by detecting other devices driving the SBI bus during the same tributary as the device listening to this signal.</p> <p>This output is updated on the rising edge or SREFCLK.</p>

Pin Name	Type	Pin No.	Function
SBIDET[0] SBIDET[1]	Input	C8 A7	<p><b>SBI Bus Activity Detection (SBIDET[1:0]).</b> The SBI bus activity detect input detects tributary collisions between devices sharing the same SBI bus. Each SBI device driving the bus also drives an SBI active signal (SBIACT). This pair of activity detection inputs monitors the active signals from two other SBI devices. When unused this signal should be connected to ground.</p> <p>A collision is detected when either of SBIDET[1:0] signals are active concurrently with this device driving SBIACT. When collisions occur the SBI drivers are disabled and an interrupt is generated to signal the collision.</p> <p>These signals are sampled on the rising edge of SREFCLK.</p> <p>SBIDET[1] is shared with serial interface signal ED[7].</p>
<b>Microprocessor Interface</b>			
INTB	Output OD	A16	<p><b>Active low Open-Drain Interrupt (INTB).</b> This signal goes low when an unmasked interrupt event is detected on any of the internal interrupt sources. Note that INTB will remain low until all active, unmasked interrupt sources are acknowledged at their source.</p>
CSB	Input	D16	<p><b>Active Low Chip Select (CSB).</b> This signal is low during TEMAP register accesses. CSB has an integral pull up resistor.</p>
RDB	Input	B16	<p><b>Active Low Read Enable (RDB).</b> This signal is low during TEMAP register read accesses. The TEMAP drives the D[7:0] bus with the contents of the addressed register while RDB and CSB are low.</p>
WRB	Input	C15	<p><b>Active Low Write Strobe (WRB).</b> This signal is low during a TEMAP register write access. The D[7:0] bus contents are clocked into the addressed register on the rising WRB edge while CSB is low.</p>

Pin Name	Type	Pin No.	Function
D[0] D[1] D[2] D[3] D[4] D[5] D[6] D[7]	I/O	C14 B14 A14 D14 C13 B13 A13 D13	<b>Bidirectional Data Bus (D[7:0])</b> . This bus provides TEMAP register read and write accesses.
A[0] A[1] A[2] A[3] A[4] A[5] A[6] A[7] A[8] A[9] A[10] A[11] A[12] A[13]	Input	A17 C16 D18 D19 B17 A18 A19 A20 C18 B19 B20 A21 C19 B21	<b>Address Bus (A[13:0])</b> . This bus selects specific registers during TEMAP register accesses.  Signal A[13] selects between normal mode and test mode register access. A[13] has an integral pull down resistor.
RSTB	Input	A22	<b>Active Low Reset (RSTB)</b> . This signal provides an asynchronous TEMAP reset. RSTB is a Schmitt triggered input with an integral pull up resistor.
ALE	Input	D17	<b>Address Latch Enable (ALE)</b> . This signal is active high and latches the address bus A[13:0] when low. When ALE is high, the internal address latches are transparent. It allows the TEMAP to interface to a multiplexed address/data bus. The ALE input has an integral pull up resistor.
<b>JTAG Interface</b>			
TCK	Input	C3	<b>Test Clock (TCK)</b> . This signal provides timing for test operations that can be carried out using the IEEE P1149.1 test access port.

Pin Name	Type	Pin No.	Function
TMS	Input	C2	<b>Test Mode Select (TMS).</b> This signal controls the test operations that can be carried out using the IEEE P1149.1 test access port. TMS is sampled on the rising edge of TCK. TMS has an integral pull up resistor.
TDI	Input	C4	<b>Test Data Input (TDI).</b> This signal carries test data into the TEMAP via the IEEE P1149.1 test access port. TDI is sampled on the rising edge of TCK. TDI has an integral pull up resistor.
TDO	Output	B3	<b>Test Data Output (TDO).</b> This signal carries test data out of the TEMAP via the IEEE P1149.1 test access port. TDO is updated on the falling edge of TCK. TDO is a tri-state output which is inactive except when scanning of data is in progress.
TRSTB	Input	B1	<b>Active low Test Reset (TRSTB).</b> This signal provides an asynchronous TEMAP test access port reset via the IEEE P1149.1 test access port. TRSTB is a Schmitt triggered input with an integral pull up resistor. TRSTB must be asserted during the power up sequence.  Note that if not used, TRSTB must be connected to the RSTB input.

Pin Name	Type	Pin No.	Function
<b>Unconnected Pins</b>			
		AA2 V3 W20 AA22 Y21 W21 K22 K21 Y1 W1 F4 G1 V20 Y22 K20 J19 W4 V1 E1 U19 R22 J22 J20 K1 K2 T4 A1 B2	No Connection

Pin Name	Type	Pin No.	Function
<b>Power and Ground Pins</b>			
VDD3.3[17] VDD3.3[16] VDD3.3[15] VDD3.3[14] VDD3.3[13] VDD3.3[12] VDD3.3[11] VDD3.3[10] VDD3.3[9] VDD3.3[8] VDD3.3[7] VDD3.3[6] VDD3.3[5] VDD3.3[4] VDD3.3[3] VDD3.3[2] VDD3.3[1]	Power	N2 AA12 L21 C12 F3 M4 U3 Y5 AA9 AA14 Y18 U20 M21 F20 C17 B11 D5	<b>Power (VDD3.3[17:1]).</b> The VDD3.3[17:1] pins should be connected to a well decoupled +3.3V DC power supply.
VDD2.5[8] VDD2.5[7] VDD2.5[6] VDD2.5[5] VDD2.5[4] VDD2.5[3] VDD2.5[2] VDD2.5[1]	Power	J2 R2 AA8 AA15 R21 H21 A15 C9	<b>Power (VDD2.5[8:1]).</b> The VDD2.5[8:1] pins should be connected to a well-decoupled +2.5V DC power supply.

Pin Name	Type	Pin No.	Function
VSS3.3[22] VSS3.3[21] VSS3.3[20] VSS3.3[19] VSS3.3[18] VSS3.3[17] VSS3.3[16] VSS3.3[15] VSS3.3[14] VSS3.3[13] VSS3.3[12] VSS3.3[11] VSS3.3[10] VSS3.3[9] VSS3.3[8] VSS3.3[7] VSS3.3[6] VSS3.3[5] VSS3.3[4] VSS3.3[3] VSS3.3[2] VSS3.3[1]	Ground	N3 Y12 L20 B12 E2 L4 V2 AA4 Y9 W11 Y14 Y17 AA19 V21 M20 J21 E21 B18 D15 C11 B8 C6	<b>Ground (VSS3.3[22:1]).</b> The VSS3.3[22:1] pins should be connected to GND.
VSS2.5[13] VSS2.5[12] VSS2.5[11] VSS2.5[10] VSS2.5[9] VSS2.5[8] VSS2.5[7] VSS2.5[6] VSS2.5[5] VSS2.5[4] VSS2.5[3] VSS2.5[2] VSS2.5[1]		N4 M2 N1 P4 P1 J3 R3 Y8 Y15 R20 H20 B15 B9	<b>Ground (VSS2.5[13:1]).</b> The VSS2.5[13:1] pins should be connected to GND.

## NOTES ON PIN DESCRIPTIONS:

1. All TEMAP inputs and bi-directionals present minimum capacitive loading and operate at TTL logic levels.

2. All TEMAP outputs and bi-directionals have at least 2 mA drive capability. The bidirectional data bus outputs, D[7:0], have 4 mA drive capability. The outputs TCLK, TPOS/TDAT, TNEG/TMFP, RGAPCLK/RSCLK, RDATAO, RFPO/RMFPO, ROVRHD, TFPO/TMFPO/TGAPCLK, SBIACT, LAOE, RECVCLK1, RECVCLK2 and INTB have 4 mA drive capability. The SBI outputs and telecom bus outputs, SDDATA[7:0], SDDP, SDPL, SDV5, SAJUST\_REQ, LAC1J1V1, LADATA[7:0], LADP and LAPL, have 8mA drive capability. The bidirectional SBI signal SC1FP has 8mA drive capability.
3. IOL = -2mA for others.
4. Inputs RSTB, ALE, TMS, TDI, TRSTB and CSB have internal pull-up resistors.
5. Input A[13] has an internal pull-down resistor.
6. All unused inputs should be connected to GROUND.
7. All TEMAP outputs can be tristated under control of the IEEE P1149.1 test access port, even those which do not tristate under normal operation. All outputs and bi-directionals are 5V tolerant when tristated.
8. Power to the VDD3.3 and VDDQ pins should be applied *before* power to the VDD2.5 pins is applied. Similarly, power to the VDD2.5 pins should be removed *before* power to the VDD3.3 and VDDq pins is removed.
9. All TEMAP inputs are 5V tolerant.

## **9 FUNCTIONAL DESCRIPTION**

### **9.1 T1 Framer (T1-FRMR)**

The T1 framing function is provided by the T1-FRMR block. This block searches for the framing bit position in the ingress stream. It works in conjunction with the FRAM block to search for the framing bit pattern in the standard superframe (SF), or extended superframe (ESF) framing formats. When searching for frame, the FRMR simultaneously examines each of the 193 (SF) or each of the 772 (ESF) framing bit candidates. The FRAM block is addressed and controlled by the FRMR while frame synchronization is acquired.

The time required to acquire frame alignment to an error-free ingress stream, containing randomly distributed channel data (i.e. each bit in the channel data has a 50% probability of being 1 or 0), is dependent upon the framing format. For SF format, the T1-FRMR block will determine frame alignment within 4.4ms 99 times out of 100. For ESF format, the T1-FRMR will determine frame alignment within 15 ms 99 times out of 100.

Once the T1-FRMR has found frame, the ingress data is continuously monitored for framing bit errors, bit error events (a framing bit error in SF or a CRC-6 error in ESF), and severely errored framing events. The T1-FRMR also detects out-of-frame, based on a selectable ratio of framing bit errors.

The T1-FRMR can also be disabled to allow reception of unframed data.

### **9.2 E1 Framer (E1-FRMR)**

The E1 framing function is provided by the E1-FRMR block. The E1-FRMR block searches for basic frame alignment, CRC multiframe alignment, and channel associated signaling (CAS) multiframe alignment in the incoming recovered PCM stream.

Once the E1-FRMR has found basic (or FAS) frame alignment, the incoming PCM data stream is continuously monitored for FAS/NFAS framing bit errors. Framing bit errors are accumulated in the framing bit error counter contained in the PMON block. Once the E1-FRMR has found CRC multiframe alignment, the PCM data stream is continuously monitored for CRC multiframe alignment pattern errors, and CRC-4 errors. CRC-4 errors are accumulated in the CRC error counter of the PMON block. Once the E1-FRMR has found CAS multiframe alignment, the PCM data is continuously monitored for CAS multiframe alignment pattern errors. The E1-FRMR also detects and indicates loss of basic frame, loss of CRC multiframe, and loss of CAS multiframe, based

on user-selectable criteria. The reframe operation can be initiated by software (via the E1-FRMR Frame Alignment Options Register), by excessive CRC errors, or when CRC multiframe alignment is not found within 400 ms. The E1-FRMR also identifies the position of the frame, the CAS multiframe, and the CRC multiframe.

The E1-FRMR extracts the contents of the International bits (from both the FAS frames and the NFAS frames), the National bits, and the Extra bits (from timeslot 16 of frame 0 of the CAS multiframe), and stores them in the E1-FRMR International/National Bits register and the E1-FRMR Extra Bits register. Moreover, the FRMR also extracts submultiframe-aligned 4-bit codewords from each of the National bit positions Sa4 to Sa8, and stores them in microprocessor-accessible registers that are updated every CRC submultiframe.

The E1-FRMR identifies the raw bit values for the Remote (or distant frame) Alarm (bit 3 in timeslot 0 of NFAS frames) and the Remote Signaling Multiframe (or distant multiframe) Alarm (bit 6 of timeslot 16 of frame 0 of the CAS multiframe) via the E1-FRMR International/National Bits Register, and the E1-FRMR Extra Bits Register respectively. Access is also provided to the "debounced" remote alarm and remote signaling multiframe alarm bits which are set when the corresponding signals have been a logic 1 for 2 or 3 consecutive occurrences, as per Recommendation O.162. Detection of AIS and timeslot 16 AIS are provided. AIS is also integrated, and an AIS Alarm is indicated if the AIS condition has persisted for at least 100 ms. The out of frame (OOF=1) condition is also integrated, indicating a Red Alarm if the OOF condition has persisted for at least 100 ms.

An interrupt may be generated to signal a change in the state of any status bits (OOF, OOSMF, OOCMF, AIS or RED), and to signal when any event (RAI, RMAI, AISD, TS16AISD, COFA, FER, SMFER, CMFER, CRCE or FEBE) has occurred. Additionally, interrupts may be generated every frame, CRC submultiframe, CRC multiframe or signaling multiframe.

### **Basic Frame Alignment Procedure**

The E1-FRMR searches for basic frame alignment using the algorithm defined in ITU-T Recommendation G.706 sections 4.1.2 and 4.2.

The algorithm finds frame alignment by using the following sequence:

1. Search for the presence of the correct 7-bit FAS ('0011011');
2. Check that the FAS is absent in the following frame by verifying that bit 2 of the assumed non-frame alignment sequence (NFAS) TS 0 byte is a logic 1;
3. Check that the correct 7-bit FAS is present in the assumed TS 0 byte of the next frame.

If either of the conditions in steps 2 or 3 are not met, a new search for frame alignment is initiated in the bit immediately following the second 7-bit FAS sequence check. This "hold-off" is done to ensure that new frame alignment searches are done in the next bit position, modulo 512. This facilitates the discovery of the correct frame alignment, even in the presence of fixed timeslot data imitating the FAS.

These algorithms provide robust framing operation even in the presence of random bit errors: framing with algorithm #1 or #2 provides a 99.98% probability of finding frame alignment within 1 ms in the presence of  $10^{-3}$  bit error rate and no mimic patterns.

Once frame alignment is found, the block sets the OOF indication low, indicates a change of frame alignment (if it occurred), and monitors the frame alignment signal, indicating errors occurring in the 7-bit FAS pattern and in bit 2 of NFAS frames, and indicating the debounced value of the Remote Alarm bit (bit 3 of NFAS frames). Using debounce, the Remote Alarm bit has  $<0.00001\%$  probability of being falsely indicated in the presence of a  $10^{-3}$  bit error rate. The block declares loss of frame alignment if 3 consecutive FASs have been received in error or, additionally, if bit 2 of NFAS frames has been in error for 3 consecutive occasions. In the presence of a random  $10^{-3}$  bit error rate the frame loss criteria provides a mean time to falsely lose frame alignment of  $>12$  minutes.

The E1-FRMR can be forced to initiate a basic frame search at any time when any of the following conditions are met:

- the software re-frame bit in the E1-FRMR Frame Alignment Options register goes to logic 1;
- the CRC Frame Find Block is unable to find CRC multiframe alignment; or
- the CRC Frame Find Block accumulates excessive CRC evaluation errors ( $\geq 915$  CRC errors in 1 second) and is enabled to force a re-frame under that condition.

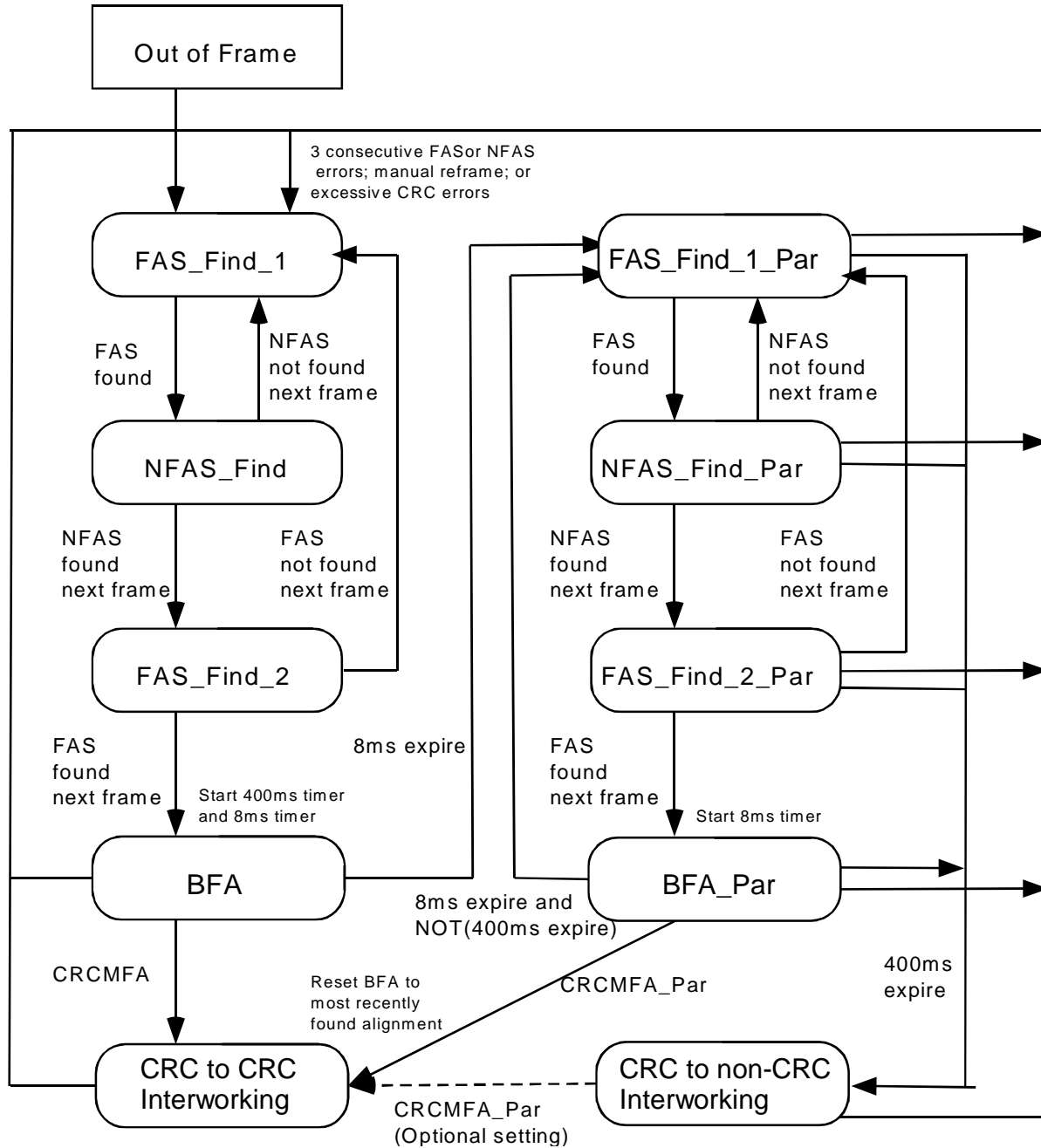
### **CRC Multiframe Alignment Procedure**

The E1-FRMR searches for CRC multiframe alignment by observing whether the International bits (bit 1 of TS 0) of NFAS frames follow the CRC multiframe alignment pattern. Multiframe alignment is declared if at least two valid CRC multiframe alignment signals are observed within 8 ms, with the time separating two alignment signals being a multiple of 2 ms

Once CRC multiframe alignment is found, the OOCMFV register bit is set to logic 0, and the E1-FRMR monitors the multiframe alignment signal, indicating errors occurring in the 6-bit MFAS pattern, errors occurring in the received CRC and the value of the FEBE bits (bit 1 of frames 13 and 15 of the multiframe). The E1-FRMR declares loss of CRC multiframe alignment if basic frame alignment is lost. However, once CRC multiframe alignment is found, it cannot be lost due to errors in the 6-bit MFAS pattern.

Under the CRC-to-non-CRC interworking algorithm, if the E1-FRMR can achieve basic frame alignment with respect to the incoming PCM data stream, but is unable to achieve CRC-4 multiframe alignment within the subsequent 400 ms, the distant end is assumed to be a non CRC-4 interface. The details of this algorithm are illustrated in the state diagram in Figure 7.

**Figure 7 - CRC Multiframe Alignment Algorithm**



**Table 1 - E1-FRMR Framing States**

<b>State</b>	<b>Out of Frame</b>	<b>Out of Offline Frame</b>
FAS_Find_1	Yes	No
NFAS_Find	Yes	No
FAS_Find_2	Yes	No
BFA	No	No
CRC to CRC Interworking	No	No
FAS_Find_1_Par	No	Yes
NFAS_Find_Par	No	Yes
FAS_Find_2_Par	No	Yes
BFA_Par	No	No
CRC to non-CRC Interworking	No	No

The states of the primary basic framer and the parallel/offline framer in the E1-FRMR block at each stage of the CRC multiframe alignment algorithm are shown in Table 1.

From an out of frame state, the E1-FRMR attempts to find basic frame alignment in accordance with the FAS/NFAS/FAS G.706 Basic Frame Alignment procedure outlined above. Upon achieving basic frame alignment, a 400 ms timer is started, as well as an 8 ms timer. If two CRC multiframe alignment signals separated by a multiple of 2 ms are observed before the 8 ms timer has expired, CRC multiframe alignment is declared.

If the 8 ms timer expires without achieving multiframe alignment, a new offline search for basic frame alignment is initiated. This search is performed in accordance with the Basic Frame Alignment procedure outlined above. However, this search does not immediately change the actual basic frame alignment of the system (i.e., PCM data continues to be processed in accordance with the first basic frame alignment found after an out of frame state while this frame alignment search occurs as a parallel operation).

When a new basic frame alignment is found by this offline search, the 8 ms timer is restarted. If two CRC multiframe alignment signals separated by a multiple of 2 ms are observed before the 8 ms timer has expired, CRC multiframe alignment is declared and the basic frame alignment is set accordingly (i.e., the basic frame alignment is set to correspond to the frame alignment found by the parallel offline search, which is also the basic frame alignment corresponding to the newly found CRC multiframe alignment).

Subsequent expirations of the 8 ms timer will likewise reinitiate a new search for basic frame alignment. If, however, the 400 ms timer expires at any time during this procedure, the E1-FRMR stops searching for CRC multiframe alignment and declares CRC-to-non-CRC interworking. In this mode, the E1-FRMR may be optionally set to either halt searching for CRC multiframe altogether, or may

continue searching for CRC multiframe alignment using the established basic frame alignment. In either case, no further adjustments are made to the basic frame alignment, and no offline searches for basic frame alignment occur once CRC-to-non-CRC interworking is declared: it is assumed that the established basic frame alignment at this point is correct.

### **AIS Detection**

When an unframed all-ones receive data stream is received, an AIS defect is indicated by setting the AISD bit to logic 1 when fewer than three zero bits are received in 512 consecutive bits or, optionally, in each of two consecutive periods of 512 bits. The AISD bit is reset to logic 0 when three or more zeros in 512 consecutive bits or in each of two consecutive periods of 512 bits. Finding frame alignment will also cause the AISD bit to be set to logic 0.

### **Signaling Frame Alignment**

Once the basic frame alignment has been found, the E1-FRMR searches for Channel Associated Signaling (CAS) multiframe alignment using the following G.732 compliant algorithm: signaling multiframe alignment is declared when at least one non-zero time slot 16 bit is observed to precede a time slot 16 containing the correct CAS alignment pattern, namely four zeros ("0000") in the first four bit positions of timeslot 16.

Once signaling multiframe alignment has been found, the E1-FRMR sets the OOSMFV bit of the E1-FRMR Framing Status register to logic 0, and monitors the signaling multiframe alignment signal, indicating errors occurring in the 4-bit pattern, and indicating the debounced value of the Remote Signaling Multiframe Alarm bit (bit 6 of timeslot 16 of frame 0 of the multiframe). Using debounce, the Remote Signaling Multiframe Alarm bit has < 0.00001% probability of being falsely indicated in the presence of a  $10^{-3}$  bit error rate.

The block declares loss of CAS multiframe alignment if two consecutive CAS multiframe alignment signals have been received in error, or additionally, if all the bits in time slot 16 are logic 0 for 1 or 2 (selectable) CAS multiframes. Loss of CAS multiframe alignment is also declared if basic frame alignment has been lost.

### **National Bit Extraction**

The E1-FRMR extracts and assembles the submultiframe-aligned National bit codewords Sa4[1:4], Sa5[1:4], Sa6[1:4], Sa7[1:4] and Sa8[1:4]. The corresponding register values are updated upon generation of the CRC submultiframe interrupt.

This E1-FRMR also detects the V5.2 link ID signal, which is detected when 2 out of 3 Sa7 bits are zeros. Upon reception of this Link ID signal, the V52LINKV bit of the E1-FRMR Framing Status register is set to logic 1. This bit is cleared to logic 0 when 2 out of 3 Sa7 bits are ones.

### Alarm Integration

The OOF and the AIS defects are integrated, verifying that each condition has persisted for 104 ms ( $\pm 6$  ms) before indicating the alarm condition. The alarm is removed when the condition has been absent for 104 ms ( $\pm 6$  ms).

The AIS alarm algorithm accumulates the occurrences of AISD (AIS detection). The E1-FRMR counts the occurrences of AISD over a 4 ms interval and indicates a valid AIS is present when 13 or more AISD indications (of a possible 16) have been received. Each interval with a valid AIS presence indication increments an interval counter which declares AIS Alarm when 25 valid intervals have been accumulated. An interval with no valid AIS presence indication decrements the interval counter. The AIS Alarm declaration is removed when the counter reaches 0. This algorithm provides a 99.8% probability of declaring an AIS Alarm within 104 ms in the presence of a  $10^{-3}$  mean bit error rate.

The Red alarm algorithm monitors occurrences of OOF over a 4 ms interval, indicating a valid OOF interval when one or more OOF indications occurred during the interval, and indicating a valid in frame (INF) interval when no OOF indication occurred for the entire interval. Each interval with a valid OOF indication increments an interval counter which declares Red Alarm when 25 valid intervals have been accumulated. An interval with valid INF indication decrements the interval counter; the Red Alarm declaration is removed when the counter reaches 0. This algorithm biases OOF occurrences, leading to declaration of Red alarm when intermittent loss of frame alignment occurs.

The E1-FRMR can also be disabled to allow reception of unframed data.

### **9.3 Performance Monitor Counters (T1/E1-PMON)**

The Performance Monitor Counters function is provided by the PMON block. The block accumulates CRC error events, Frame Synchronization bit error events, and Out Of Frame events, or optionally, Change of Frame Alignment (COFA) events with saturating counters over consecutive intervals as defined by the period of the supplied transfer clock signal (typically 1 second). When the transfer clock signal is applied, the PMON transfers the counter values into holding registers and resets the counters to begin accumulating events for the interval. The counters are reset in such a manner that error events occurring during the reset are not missed. If the holding registers are not read between successive transfer clocks, an OVERRUN register bit is asserted.

Generation of the transfer clock within the TEMAP chip is performed by writing to any counter register location or by writing to the Global PMON Update register. The holding register addresses are contiguous to facilitate faster polling operations.

#### **9.4 T1 Alarm Integrator (ALMI)**

The T1 Alarm Integration function is provided by the ALMI block. This block detects the presence of Yellow, Red, and AIS Carrier Fail Alarms (CFA) in SF, or ESF formats. The alarm detection and integration is compatible with the specifications defined in ANSI T1.403 and TR-TSY-000191.

The ALMI block declares the presence of Yellow alarm when the Yellow pattern has been received for 425 ms ( $\pm 50$  ms); the Yellow alarm is removed when the Yellow pattern has been absent for 425 ms ( $\pm 50$  ms). The presence of Red alarm is declared when an out-of-frame condition has been present for 2.55 sec ( $\pm 40$  ms); the Red alarm is removed when the out-of-frame condition has been absent for 16.6 sec ( $\pm 500$  ms). The presence of AIS alarm is declared when an out-of-frame condition and all-ones in the PCM data stream have been present for 1.5 sec ( $\pm 100$  ms); the AIS alarm is removed when the AIS condition has been absent for 16.8 sec ( $\pm 500$  ms).

CFA alarm detection algorithms operate in the presence of a  $10^{-3}$  bit error rate.

The ALMI also indicates the presence or absence of the Yellow, Red, and AIS alarm signal conditions over 40 ms, 40 ms, and 60 ms intervals, respectively, allowing an external microprocessor to integrate the alarm conditions via software with any user-specific algorithms. Alarm indication is provided through internal register bits.

#### **9.5 Receive and Transmit Digital Jitter Attenuator (RJAT, TJAT)**

The Digital Jitter Attenuation function is provided by the DJAT blocks. Each framer in the TEMAP contains two separate jitter attenuators, one between the receive demultiplexed or demapped T1 or E1 link and the ingress interface (RJAT) and the other between the egress interface and the transmit T1 or E1 link to be multiplexed into DS3 or mapped into SONET (TJAT). Each DJAT block receives jittered data and stores the stream in a FIFO timed to the associated receive jittered clock. The jitter attenuated data emerges from the FIFO timed to the jitter attenuated clock. In the RJAT, the jitter attenuated clock (ICLK[x]) is referenced to the demultiplexed or demapped tributary receive clock. In the TJAT, the jitter attenuated transmit tributary clock feeding the M13 multiplexer or SONET/SDH mapper may be referenced to either CTCLK, CECLK, or the tributary receive clock.

In T1 mode each jitter attenuator generates its output clock by adaptively dividing the 37.056 MHz XCLK signal according to the phase difference between the jitter attenuated clock and the input reference clock. Jitter fluctuations in the phase of the reference clock are attenuated by the phase-locked loop within each DJAT so that the frequency of the jitter attenuated clock is equal to the average frequency of the reference. To best fit the jitter attenuation transfer function recommended by TR 62411, phase fluctuations with a jitter frequency above 6.6 Hz are attenuated by 6 dB per octave of jitter frequency. Wandering phase fluctuations with frequencies below 6.6 Hz are tracked by the jitter attenuated clock. The jitter attenuated clock (ICLK[x] for the RJAT and transmit clock for the TJAT) are used to read data out of the FIFO.

In E1 mode each jitter attenuator generates the jitter-free 2.048 MHz output clock by adaptively dividing the 49.152 MHz XCLK signal according to the phase difference between the jitter attenuated clock and input reference clock. Fluctuations in the phase of the input data clock are attenuated by the phase-locked loop within DJAT so that the frequency of the jitter attenuated clock is equal to the average frequency of the input data clock. Phase fluctuations with a jitter frequency above 8.8 Hz are attenuated by 6 dB per octave of jitter frequency. Wandering phase fluctuations with frequencies below 8.8 Hz are tracked by the jitter attenuated clock. To provide a smooth flow of data out of DJAT, the jitter attenuated clock is used to read data out of the FIFO.

The TJAT and RJAT have programmable divisors in order to generate the jitter attenuated clock from the various reference sources. The divisors are set using the TJAT and RJAT Jitter Attenuator Divider N1 and N2 registers. The following formula must be met in order to select the values of N1 and N2:

$$F_{in}/(N1 + 1) = F_{out}/(N2 + 1)$$

where  $F_{in}$  is the input reference clock frequency and  $F_{out}$  is the output jitter attenuated clock frequency. The values on N1 and N2 can range between 1 and 256.  $F_{in}$  ranges from 8KHz to 2.048MHz in 8KHz increments.

If the FIFO read pointer comes within one bit of the write pointer, DJAT will track the jitter of the input clock. This permits the phase jitter to pass through unattenuated, inhibiting the loss of data.

### Jitter Characteristics

Each DJAT Block provides excellent jitter tolerance and jitter attenuation while generating minimal residual jitter. In T1 mode each DJAT can accommodate up to 28 Ulpp of input jitter at jitter frequencies above 6 Hz. For jitter frequencies below 6 Hz, more correctly called wander, the tolerance increases 20 dB per decade. In E1 mode each DJAT can accommodate up to 35 Ulpp of input jitter at

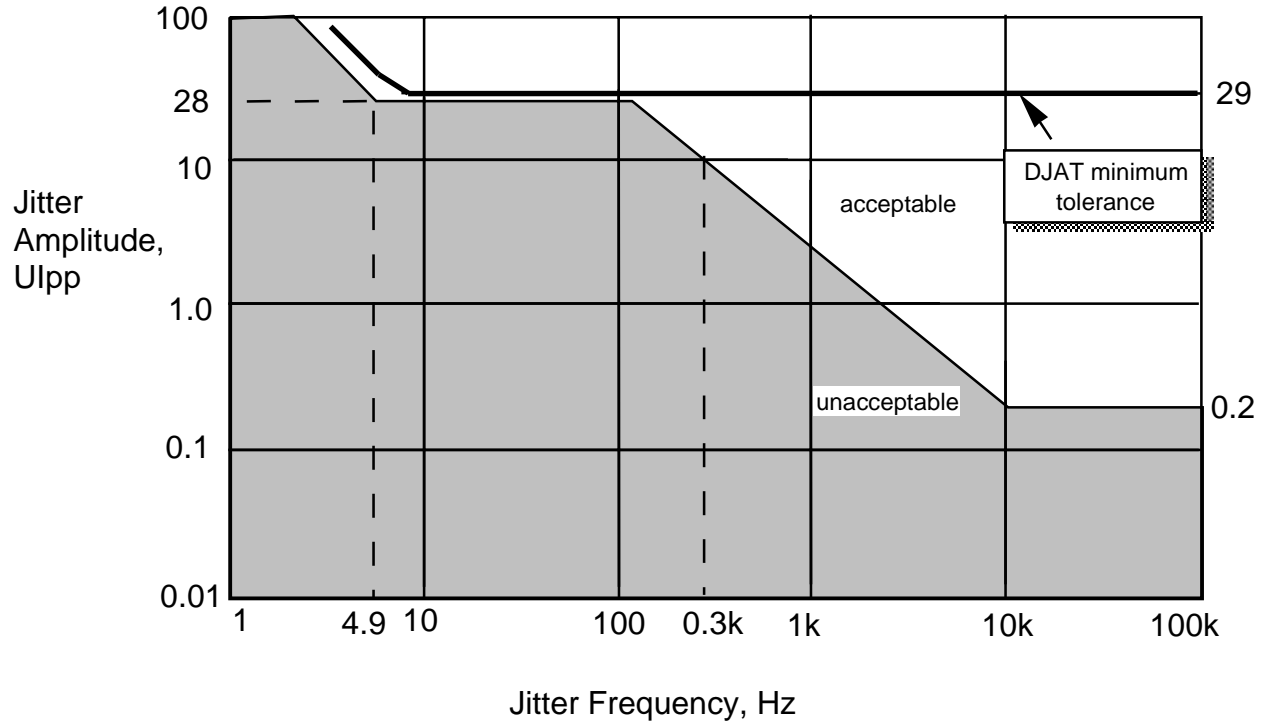
jitter frequencies above 9 Hz. For jitter frequencies below 9 Hz, more correctly called wander, the tolerance increases 20 dB per decade. In most applications the each DJAT Block will limit jitter tolerance at lower jitter frequencies only. For high frequency jitter, above 10 kHz for example, other factors such as clock and data recovery circuitry may limit jitter tolerance and must be considered. For low frequency wander, below 10 Hz for example, other factors such as slip buffer hysteresis may limit wander tolerance and must be considered. The DJAT blocks meet the stringent low frequency jitter tolerance requirements of AT&T TR 62411, ITU-T Recommendation G.823 and thus allow compliance with this standard and the other less stringent jitter tolerance standards cited in the references.

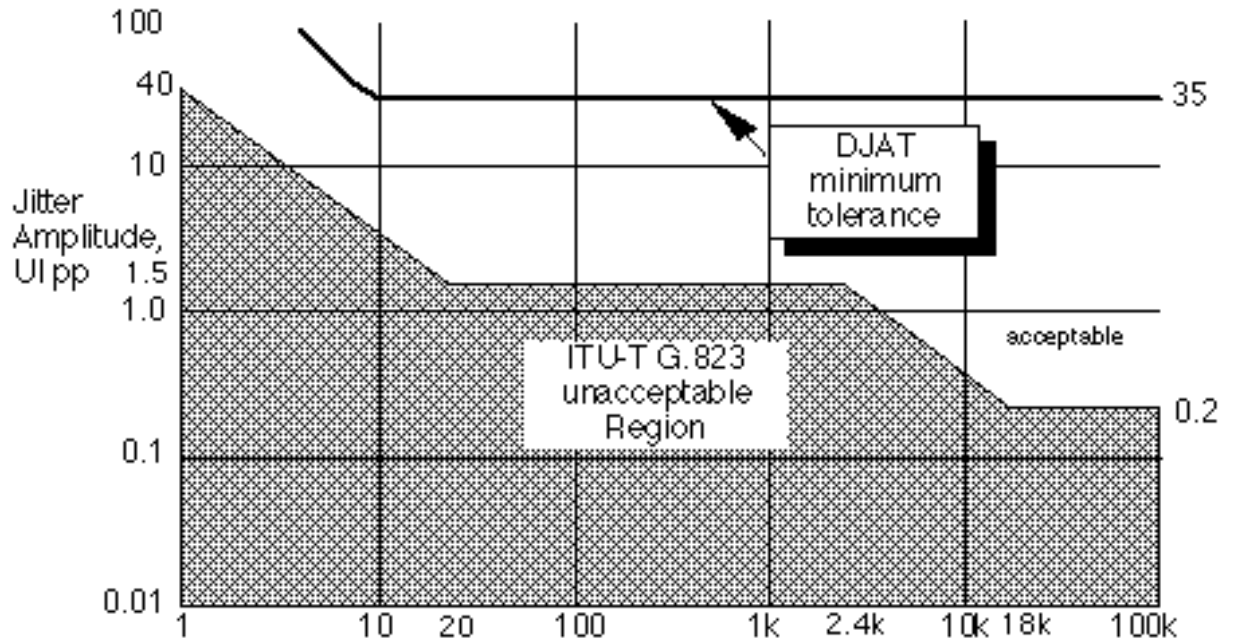
The DJAT exhibits negligible jitter gain for jitter frequencies below 6.6 Hz, and attenuates jitter at frequencies above 6.6 Hz by 20 dB per decade in T1 mode. It exhibits negligible jitter gain for jitter frequencies below 8.8 Hz, and attenuates jitter at frequencies above 8.8 Hz by 20 dB per decade in E1 mode. In most applications the DJAT Blocks will determine jitter attenuation for higher jitter frequencies only. Wander, below 10 Hz for example, will essentially be passed unattenuated through DJAT. Jitter, above 10 Hz for example, will be attenuated as specified, however, outgoing jitter may be dominated by the generated residual jitter in cases where incoming jitter is insignificant. This generated residual jitter is directly related to the use of 24X (37.056 MHz or 49.152 MHz) digital phase locked loop for transmit clock generation. DJAT meets the jitter transfer requirements of AT&T TR 62411. The DJAT allows the implied T1 jitter attenuation requirements for a TE or NT1 given in ANSI Standard T1.408, and the implied jitter attenuation requirements for a type II customer interface given in ANSI T1.403 to be met. The DJAT meets the E1 jitter attenuation requirements of the ITU-T Recommendations G.737, G.738, G.739 and G.742.

### **Jitter Tolerance**

Jitter tolerance is the maximum input phase jitter at a given jitter frequency that a device can accept without exceeding its linear operating range, or corrupting data. For T1 modes the DJAT input jitter tolerance is 29 Unit Intervals peak-to-peak (UIpp) with a worst case frequency offset of 354 Hz. For E1 modes the input jitter tolerance is 35 Unit Intervals peak-to-peak (UIpp) with a worst case frequency offset of 308 Hz. In either mode jitter tolerance is 48 UIpp with no frequency offset. The frequency offset is the difference between the frequency of XCLK divided by 24 and that of the input data clock.

**Figure 8 - DJAT Jitter Tolerance T1 Modes**

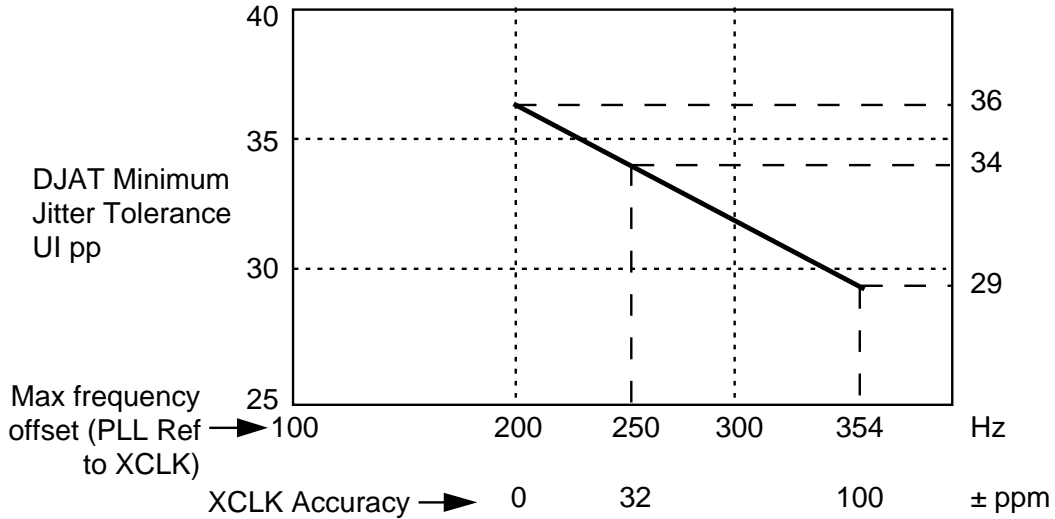


**Figure 9 - DJAT Jitter Tolerance E1 Modes**


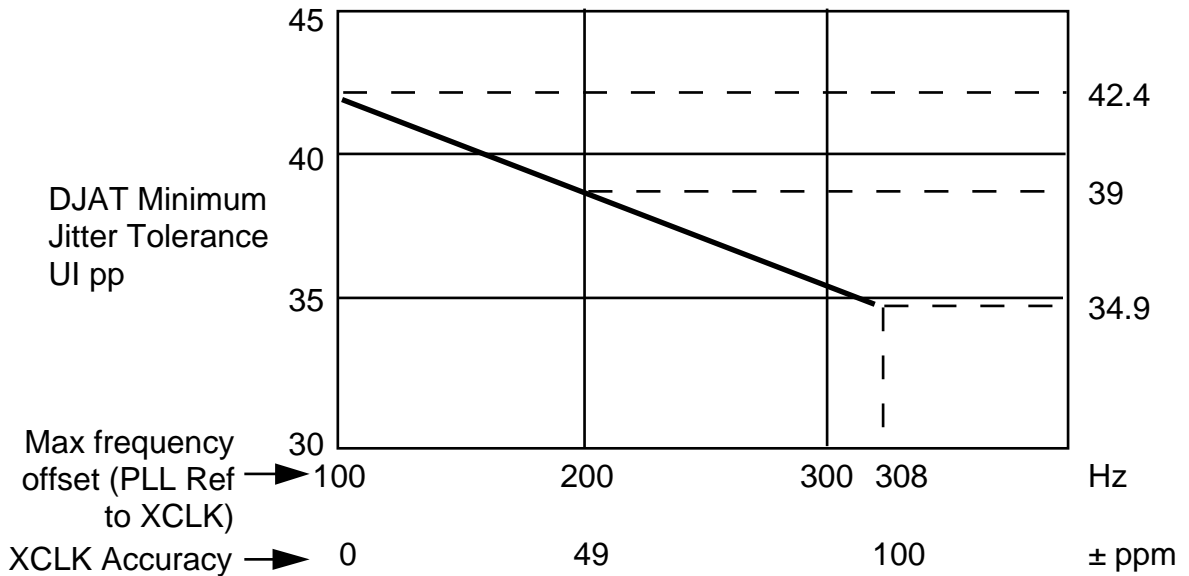
The accuracy of the XCLK frequency and that of the reference clock used to generate the jitter attenuated clock have an effect on the minimum jitter tolerance. Given that the DJAT PLL reference clock accuracy can be  $\pm 200$  Hz from 1.544 MHz or be  $\pm 103$  Hz from 2.048 MHz, and that the XCLK input accuracy can be  $\pm 100$  ppm from 37.056 MHz or  $\pm 100$  ppm from 49.152 MHz, the minimum jitter tolerance for various differences between the frequency of PLL reference clock and  $XCLK \div 24$  are shown in Figure 10 and Figure 11.

An XCLK input accuracy of  $\pm 100$  ppm is only acceptable if an accurate line rate reference is provided. If TJAT is left to free-run without a reference, or referenced to a derivative of XCLK, then XCLK accuracy must be  $\pm 32$  ppm.

**Figure 10 - DJAT Minimum Jitter Tolerance vs. XCLK Accuracy T1 Modes**



**Figure 11 - DJAT Minimum Jitter Tolerance vs. XCLK Accuracy E1 Modes**

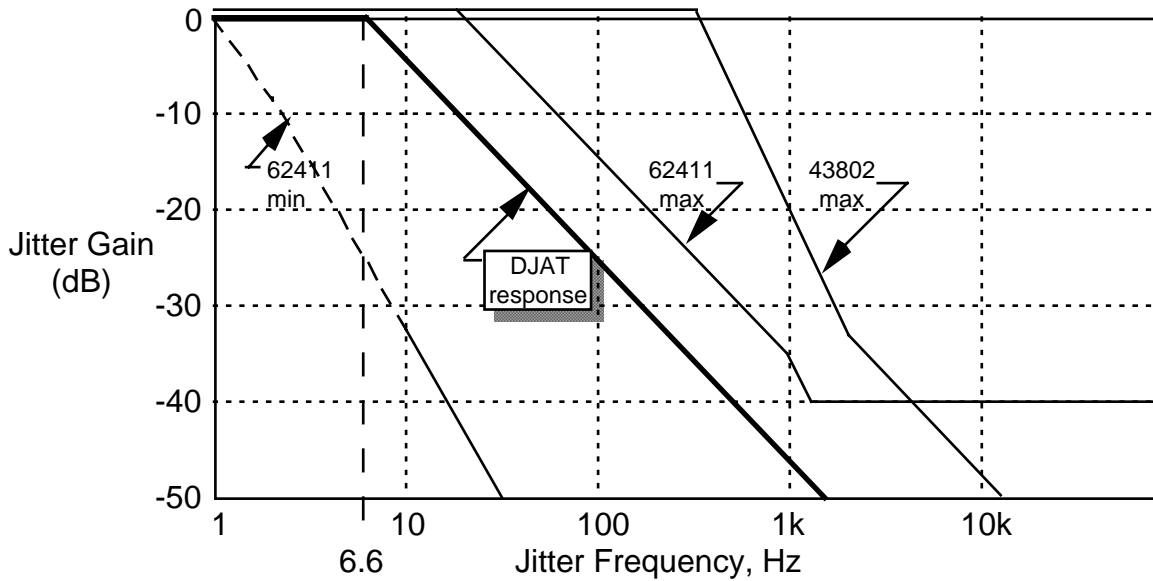


**Jitter Transfer**

The output jitter in T1 mode for jitter frequencies from 0 to 6.6 Hz is no more than 0.1 dB greater than the input jitter, excluding the residual jitter. Jitter

frequencies above 6.6 Hz are attenuated at a level of 6 dB per octave, as shown in Figure 12.

**Figure 12 - DJAT Jitter Transfer T1 Modes**



The output jitter in E1 mode for jitter frequencies from 0 to 8.8 Hz is no more than 0.1 dB greater than the input jitter, excluding the residual jitter. Jitter frequencies above 8.8 Hz are attenuated at a level of 6 dB per octave, as shown in Figure 13.

## Figure 13 - DJAT Jitter Transfer E1 Modes

### Frequency Range

In the non-attenuating mode for T1 rates, that is, when the FIFO is within one UI of overrunning or under running, the tracking range is 1.48 to 1.608 MHz. The guaranteed linear operating range for the jittered input clock is 1.544 MHz  $\pm$  200 Hz with worst case jitter (29 UIpp) and maximum XCLK frequency offset ( $\pm$  100 ppm). The nominal range is 1.544 MHz  $\pm$  963 Hz with no jitter or XCLK frequency offset.

In the non-attenuating mode for E1 rates the tracking range is 1.963 to 2.133 MHz. The guaranteed linear operating range for the jittered input clock is 2.048 MHz  $\pm$  1278 Hz with worst case jitter (42 UIpp) and maximum XCLK frequency offset ( $\pm$  100 ppm).

### 9.6 Timing Options (TOPS)

The Timing Options block provides a means of selecting the source of the internal input clock to the TJAT block, the reference clock for the TJAT digital PLL, and the clock source used to derive the transmit clock to the M13 mux or SONET/SDH mapper.

## **9.7 Pseudo Random Binary Sequence Generation and Detection (PRBS)**

The Pseudo Random Binary Sequence Generator/Detector (PRBS) block is a software selectable PRBS generator and checker for  $2^{11}-1$ ,  $2^{15}-1$  or  $2^{20}-1$  PRBS polynomials for use in the T1 and E1 links. PRBS patterns may be generated in either the transmit or receive directions, and detected in the opposite direction.

The PRBS block can perform an auto synchronization to the expected PRBS pattern and accumulates the total number of bit errors in two 24-bit counters. The error count accumulates over the interval defined by the Global PMON Update Register. When an accumulation is forced, the holding register is updated, and the counter reset to begin accumulating for the next interval. The counter is reset in such a way that no events are missed. The data is then available in the Error Count registers until the next accumulation.

## **9.8 Pseudo Random Pattern Generation and Detection (PRGD)**

The Pseudo Random Pattern Generator/Detector (PRGD) block is a software programmable test pattern generator, receiver, and analyzer for the DS3 payload. Patterns may be generated in either the transmit or receive directions, and detected in the opposite direction. Two types of ITU-T O.151 compliant test patterns are provided : pseudo-random and repetitive.

The PRGD can be programmed to generate any pseudo-random pattern with length up to  $2^{32}-1$  bits or any user programmable bit pattern from 1 to 32 bits in length. In addition, the PRGD can insert single bit errors or a bit error rate between  $10^{-1}$  to  $10^{-7}$ .

The PRGD can be programmed to check for the generated pseudo random pattern. The PRGD can perform an auto synchronization to the expected pattern and accumulates the total number of bits received and the total number of bit errors in two 32-bit counters. The counters accumulate either over intervals defined by writes to the Pattern Detector registers, upon writes to the Global PMON Update Register or automatically once a second. When an accumulation is forced, the holding registers are updated, and the counters reset to begin accumulating for the next interval. The counters are reset in such a way that no events are missed. The data is then available in the holding registers until the next accumulation.

## **9.9 DS3 Framer (DS3-FRMR)**

The DS3 Framer (DS3-FRMR) Block integrates circuitry required for decoding a B3ZS-encoded signal and framing to the resulting DS3 bit stream. The DS3-FRMR is directly compatible with the M23 and C-bit parity DS3 applications.

The DS3-FRMR decodes a B3ZS-encoded signal and provides indications of line code violations. The B3ZS decoding algorithm and the LCV definition can be independently chosen through software. A loss of signal (LOS) defect is also detected for B3ZS encoded streams. LOS is declared when inputs RPOS and RNEG contain zeros for 175 consecutive RCLK cycles. LOS is removed when the ones density on RPOS and/or RNEG is greater than 33% for 175  $\pm$ 1 RCLK cycles.

The framing algorithm examines five F-bit candidates simultaneously. When at least one discrepancy has occurred in each candidate, the algorithm examines the next set of five candidates. When a single F-bit candidate remains in a set, the first bit in the supposed M-subframe is examined for the M-frame alignment signal (i.e., the M-bits, M1, M2, and M3 are following the 010 pattern). Framing is declared, and out-of-frame is removed, if the M-bits are correct for three consecutive M-frames while no discrepancies have occurred in the F-bits. During the examination of the M-bits, the X-bits and P-bits are ignored. The algorithm gives a maximum average reframe time of 1.5 ms.

While the DS3-FRMR is synchronized to the DS3 M-frame, the F-bit and M-bit positions in the DS3 stream are examined. An out-of-frame defect is detected when 3 F-bit errors out of 8 or 16 consecutive F-bits are observed (as selected by the M3O8 bit in the DS3 FRMR Configuration Register), or when one or more M-bit errors are detected in 3 out of 4 consecutive M-frames. The M-bit error criteria for OOF can be disabled by the MBDIS bit in the DS3 Framer Configuration register. The 3 out of 8 consecutive F-bits out-of-frame ratio provides more robust operation, in the presence of a high bit error rate, than the 3 out of 16 consecutive F-bits ratio. Either out-of-frame criteria allows an out-of-frame defect to be detected quickly when the M-subframe alignment patterns or, optionally, when the M-frame alignment pattern is lost.

Also while in-frame, line code violations, M-bit or F-bit framing bit errors, and P-bit parity errors are indicated. When C-bit parity mode is enabled, both C-bit parity errors and far end block errors are indicated. These error indications, as well as the line code violation and excessive zeros indication, are accumulated over 1 second intervals with the Performance Monitor (PMON). Note that the framer is an off-line framer, indicating both OOF and COFA events. Even if an OOF is indicated, the framer will continue indicating performance monitoring information based on the previous frame alignment.

Three DS3 maintenance signals (a RED alarm condition, the alarm indication signal, and the idle signal) are detected by the DS3-FRMR. The maintenance detection algorithm employs a simple integrator with a 1:1 slope that is based on the occurrence of "valid" M-frame intervals. For the RED alarm, an M-frame is said to be a "valid" interval if it contains a RED defect, defined as an occurrence of an OOF or LOS event during that M-frame. For AIS and IDLE, an M-frame

interval is "valid" if it contains AIS or IDLE, defined as the occurrence of less than 15 discrepancies in the expected signal pattern (1010... for AIS, 1100... for IDLE) while valid frame alignment is maintained. This discrepancy threshold ensures the detection algorithms operate in the presence of a  $10^{-3}$  bit error rate. For AIS, the expected pattern may be selected to be: the framed "1010" signal; the framed arbitrary DS3 signal and the C-bits all zero; the framed "1010" signal and the C-bits all zero; the framed all-ones signal (with overhead bits ignored); or the unframed all-ones signal (with overhead bits equal to ones). Each "valid" M-frame causes an associated integration counter to increment; "invalid" M-frames cause a decrement. With the "slow" detection option, RED, AIS, or IDLE are declared when the respective counter saturates at 127, which results in a detection time of 13.5 ms. With the "fast" detection option, RED, AIS, or IDLE are declared when the respective counter saturates at 21, which results in a detection time of 2.23 ms (i.e., 1.5 times the maximum average reframe time). RED, AIS, or IDLE are removed when the respective counter decrements to 0. DS3 Loss of Frame detection is provided as recommended by ITU-T G.783 with programmable integration periods of 1ms, 2ms, or 3ms. While integrating up to assert LOF, the counter will integrate up when the framer asserts an Out of Frame condition and integrates down when the framer de-asserts the Out of Frame condition. Once an LOF is asserted, the framer must not assert OOF for the entire integration period before LOF is deasserted.

Valid X-bits are extracted by the DS3-FRMR to provide indication of far end receive failure (FERF). A FERF defect is detected if the extracted X-bits are equal and are logic 0 ( $X1=X2=0$ ); the defect is removed if the extracted X-bits are equal and are logic 1 ( $X1=X2=1$ ). If the X-bits are not equal, the FERF status remains in its previous state. The extracted FERF status is buffered for 2 M-frames before being reported within the DS3 FRMR Status register. This buffer ensures a better than 99.99% chance of freezing the FERF status on a correct value during the occurrence of an out of frame.

When the C-bit parity application is enabled, both the far end alarm and control (FEAC) channel and the path maintenance data link are extracted. Codes in the FEAC channel are detected by the Bit Oriented Code Detector (RBOC). HDLC messages in the Path Maintenance Data Link are received by the Data Link Receiver (RDLC).

The DS3-FRMR can be enabled to automatically assert the RAI indication in the outgoing transmit stream upon detection of any combination of LOS, OOF or RED, or AIS. The DS3-FRMR can also be enabled to automatically insert C-bit Parity FEBE upon detection of receive C-bit parity error.

The DS3-FRMR may be configured to generate interrupts on error events or status changes. All sources of interrupts can be masked or acknowledged via

internal registers. Internal registers are also used to configure the DS3-FRMR. Access to these registers is via a generic microprocessor bus.

### **9.10 Performance Monitor Accumulator (DS3-PMON)**

The Performance Monitor (PMON) Block interfaces directly with the DS3 Framer (DS3-FRMR). Saturating counters are used to accumulate:

- line code violation (LCV) events
- parity error (PERR) events
- path parity error (CPERR) events
- far end block error (FEBE) events
- excess zeros (EXZS)
- framing bit error (FERR) events

Due to the off-line nature of the DS3 Framer, PMON continues to accumulate performance meters even while the DS3-FRMR has declared OOF.

When an accumulation interval is signaled by a write to the PMON register address space, the PMON transfers the current counter values into microprocessor accessible holding registers and resets the counters to begin accumulating error events for the next interval. The counters are reset in such a manner that error events occurring during the reset period are not missed.

When counter data is transferred into the holding registers, an interrupt is generated, providing the interrupt is enabled. If the holding registers have not been read since the last interrupt, an overrun status bit is set. In addition, a register is provided to indicate changes in the PMON counters since the last accumulation interval.

Whenever counter data is transferred into the holding registers, an interrupt is generated, providing the interrupt is enabled. If the holding registers have not been read since the last interrupt, an overrun status bit is set.

### **9.11 DS3 Transmitter (DS3-TRAN)**

The DS3 Transmitter (DS3-TRAN) Block integrates circuitry required to insert the overhead bits into a DS3 bit stream and produce a B3ZS-encoded signal. The T3-TRAN is directly compatible with the M23 and C-bit parity DS3 formats.

When configured for the C-bit parity application, all overhead bits are inserted. When configured for the M23 application, all overhead bits except the stuff control bits (the C-bits) are inserted; the C-bits are inserted by the upstream MX23 TSB.

Status signals such as far end receive failure (FERF), the alarm indication signal, and the idle signal can be inserted when their transmission is enabled by internal register bits. FERF can also be automatically inserted on detection of any combination of LOS, OOF or RED, or AIS by the DS3-FRMR.

A valid pair of P-bits is automatically calculated and inserted by the DS3-TRAN. When C-bit parity mode is selected, the path parity bits, and far end block error (FEBE) indications are automatically inserted.

When enabled for C-bit parity operation, the FEAC channel is sourced by the XBOC bit-oriented code transmitter. The path maintenance data link messages are sourced by the TDPR data link transmitter.

When enabled for M23 operation, the C-bits are forced to logic 1 with the exception of the C-bit Parity ID bit (first C-bit of the first M-subframe), which is forced to toggle every M-frame.

The DS3-TRAN supports diagnostic modes in which it inserts parity or path parity errors, F-bit framing errors, M-bit framing errors, invalid X or P-bits, line code violations, or all-zeros.

## **9.12 M23 Multiplexer (MX23)**

The M23 Multiplexer (MX23) integrates circuitry required to asynchronously multiplex and demultiplex seven DS2 streams into, and out of, an M23 or C-bit Parity formatted DS3 serial stream.

When multiplexing seven DS2 streams into an M23 formatted DS3 stream, the MX23 TSB performs rate adaptation to the DS3 by integral FIFO buffers, controlled by timing circuitry. The C-bits are also generated and inserted by the timing circuitry. Software control is provided to transmit DS2 AIS and DS2 payload loopback requests. The loopback request is coded by inverting one of the three C-bits (the default option is compatible with ANSI T1.107a Section 8.2.1 and TR-TSY-000009 Section 3.7). The TSB also supports generation of a C-bit Parity formatted DS3 stream by providing an internally generated DS2 rate clock corresponding to a 100% stuffing ratio. Integrated M13 applications are supported by providing an internally generated DS2 rate clock corresponding to a 39.1% stuffing ratio.

When demultiplexing seven DS2 streams from an M23 formatted DS3, the MX23 performs bit destuffing via interpretation of the C-bits. The MX23 also detects and indicates DS2 payload loopback requests encoded in the C-bits. As per ANSI T1.107a Section 8.2.1 and TR-TSY-000009 Section 3.7, the loopback command is identified as C3 being the inverse of C1 and C2. Because TR-TSY-000233 Section 5.3.14.1 recommends compatibility with non-compliant existing equipment, the two other loopback command possibilities are also supported. As per TR-TSY-000009 Section 3.7, the loopback request must be present for five successive M-frames before declaration of detection. Removal of the loopback request is declared when it has been absent for five successive M-frames.

DS2 payload loopback can be activated or deactivated under software control. During payload loopback the DS2 stream being looped back still continues unaffected in the demultiplex direction to the DS2 Framer. All seven demultiplexed DS2 streams can also be replaced with AIS on an individual basis under register control or they can be configured to be replaced automatically on detection of out of frame, loss of signal, RED alarm or alarm indication signal.

### **9.13 DS2 Framer (DS2-FRMR)**

The FRMR DS2 Framer integrates circuitry required for framing to a DS2 bit stream and is directly compatible with the M12 DS2 application. The FRMR can also be configured to frame to a G.747 bit stream.

The DS2 FRMR frames to a DS2 signal with a maximum average reframe time of less than 7 ms and frames to a G.747 signal with a maximum average reframe time of 1 ms. In DS2 mode, both the F-bits and M-bits must be correct for a significant period of time before frame alignment is declared. In G.747 mode, frame alignment is declared if the candidate frame alignment signal has been correct for 3 consecutive frames (in accordance with CCITT Rec. G.747 Section 4). Once in frame, the DS2 FRMR provides indications of the M-frame and M-subframe boundaries, and identifies the overhead bit positions in the incoming DS2 signal or provides indications of the frame boundaries and overhead bit positions in the incoming G.747 signal.

Depending on configuration, declaration of DS2 out-of-frame occurs when 2 out of 4 or 2 out of 5 consecutive F-bits are in error (These two ratios are recommended in TR-TSY-000009 Section 4.1.2) or when one or more M-bit errors are detected in 3 out of 4 consecutive M-frames. The M-bit error criteria for OOF can be disabled via the MBDIS bit in the DS2 Framer configuration register. In G.747 mode, out-of-frame is declared when four consecutive frame alignment signals are incorrectly received (in accordance with CCITT Rec. G.747 Section 4). Note that the DS2 framer is an off-line framer, indicating both OFF and COFA. Error events continue to be indicated even when the FRMR is indicating OOF, based on the previous frame alignment.

The RED alarm and alarm indication signal are detected by the DS2 FRMR in 9.9 ms for DS2 format and in 6.9 ms for G.747 format. The framer employs a simple integration algorithm (with a 1:1 slope) that is based on the occurrence of "valid" DS2 M-frame or G.747 frame intervals. For the RED alarm, a DS2 M-frame (or G.747 frame, depending upon the framing format selected) is said to be a "valid" interval if it contains a RED defect, defined as the occurrence of an OOF event during that M-frame (or G.747 frame). For AIS, a DS2 M-frame (or G.747 frame) is said to be a "valid" interval if it contains AIS, defined as the occurrence of less than 9 zeros while the framer is out of frame during that M-frame (or G.747 frame). The discrepancy threshold ensures the detection algorithm operates in the presence of bit error rates of up to  $10^{-3}$ . Each "valid" DS2 M-frame (or G.747 frame) causes an integration counter to increment; "non-valid" DS2 M-frame (or G.747 frame) intervals cause a decrement. RED or AIS is declared if the associated integrator count saturates at 53, resulting in a detection time of 9.9 ms for DS2 and 6.9 ms for G.747. RED or AIS declaration is deasserted when the associated count decrements to 0.

The DS2 X-bit or G.747 remote alarm indication (RAI) bit is extracted by the DS2 FRMR to provide an indication of far end receive failure. The FERF status is set to the current X/RAI state only if the two successive X/RAI bits were in the same state. The extracted FERF status is buffered for 6 DS2 M-frames or 6 G.747 frames before being reported within the DS2 FRMR Status register. This buffer ensures a virtually 100% probability of freezing the FERF status in a valid state during an out of frame occurrence in DS2 mode, and ensures a better than 99.9% probability of freezing the valid status during an OOF occurrence in G.747 mode. When an OOF occurs, the FERF value is held at the state contained in the last buffer location corresponding to the previous sixth M-frame or G.747 frame. This location is not updated until the OOF condition is deasserted. Meanwhile, the last four of the remaining five buffer locations are loaded with the frozen FERF state while the first buffer location corresponding to the current M-frame/ G.747 frame is continually updated every M-frame/G.747 frame based on the above FERF definition. Once correct frame alignment has been found and OOF is deasserted, the first buffer location will contain a valid FERF status and the remaining five buffer locations are enabled to be updated every M-frame or G.747 frame.

DS2 M-bit and F-bit framing errors are indicated as are G.747 framing word errors (or bit errors) and G.747 parity errors. These error indications are accumulated for performance monitoring purposes in internal, microprocessor readable counters. The performance monitoring accumulators continue to count error indication even while the framer is indicating OOF.

The DS2 FRMR may be configured to generate interrupts on error events or status changes. All sources of interrupts can be masked or acknowledged via internal registers. Internal registers are also used to configure the DS2 FRMR.

## **9.14 M12 Multiplexer (MX12)**

The MX12 M12 Multiplexer integrates circuitry required to asynchronously multiplex and demultiplex four DS1 streams into, and out of, an M12 formatted DS2 serial stream (as defined in ANSI T1.107 Section 7) and to support asynchronous multiplexing and demultiplexing of three 2048 kbit/s into and out of a G.747 formatted 6312 kbit/s high speed signal (as defined in CCITT Rec. G.747).

When multiplexing four DS1 streams into an M12 formatted DS2 stream, the MX12 TSB performs logical inversion on the second and fourth tributary streams. Rate adaptation to the DS2 is performed by integral FIFO buffers, controlled by timing circuitry. The FIFO buffers accommodate in excess of 5.0 U<sub>lpp</sub> of sinusoidal jitter on the DS1 clocks for all jitter frequencies. X, F, M, and C bits are also generated and inserted by the timing circuitry. Software control is provided to transmit Far End Receive Failure (FERF) indications, DS2 AIS, and DS1 payload loopback requests. The loopback request is coded by inverting one of the three C-bits (the default option is compatible with ANSI T1.107a Section 8.2.1 and TR-TSY-000009 Section 3.7). Two diagnostic options are provided to invert the transmitted F or M bits.

When demultiplexing four DS1 streams from an M12 formatted DS2, the MX12 performs bit destuffing via interpretation of the C-bits. The MX12 also detects and indicates DS1 payload loopback requests encoded in the C-bits. As per ANSI T1.107 Section 7.2.1.1 and TR-TSY-000009 Section 3.7, the loopback command is identified as C3 being the inverse of C1 and C2. Because TR-TSY-000233 Section 5.3.14.1 recommends compatibility with non-compliant existing equipment, the two other loopback command possibilities are also supported. As per TR-TSY-000009 Section 3.7, the loopback request must be present for five successive M-frames before declaration of detection. Removal of the loopback request is declared when it has been absent for five successive M-frames.

DS1 payload loopback can be activated or deactivated under software control. During payload loopback the DS1 stream being looped back still continues unaffected in the demultiplex direction. The second and fourth demultiplexed DS1 streams are logically inverted, and all four demultiplexed DS1 streams can be replaced with AIS on an individual basis.

Similar functionality supports CCITT Recommendation G.747. The FIFO is still required for rate adaptation. The frame alignment signal and parity bit are generated and inserted by the timing circuitry. Software control is provided to transmit Remote Alarm Indication (RAI), high speed signal AIS, and the reserved bit. A diagnostic option is provided to invert the transmitted frame alignment signal and parity bit.

When demultiplexing three 2048 kbit/s streams from a G.747 formatted 6312 kbit/s stream, the MX12 performs bit destuffing via interpretation of the C-bits. Tributary payload loopback can be activated or deactivated under software control. Although no remote loopback request has been defined for G.747, inversion of the third C-bit triggers a loopback request detection indication in anticipation of Recommendation G.747 refinement. All three demultiplexed 2048 kbit/s streams can be replaced with AIS on an individual basis.

### **9.15 Tributary Payload Processor (VTPP)**

The tributary payload processor (VTPP) processes the virtual tributaries within an STS-1, AU3, or TUG3. The VTPP can be configured to process either VT1.5s or VT2s within an STS-1 or either TU11s or TU12s within an AU3 or TUG3. The number of tributaries managed by each VTPP ranges from 21 (when configured to process all VT2s or equivalently all TU12s) to 28 (when configured to process all VT1.5s or equivalently all TU11s).

The Tributary payload processor is used in both the ingress and egress data paths. In the egress direction the pointer interpreter section of the VTPP can be bypassed on a per tributary basis to allow for pointer generator in the absence of valid pointers which is necessary when mapping floating transparent virtual tributaries from the SBI bus.

#### **9.15.1 Clock Generator**

The clock generator derives various clocks from the 19.44 MHz system clock and distributes them to other blocks within the tributary payload processor. The overall design is totally synchronous, with processing occurring at a 6.48 MHz rate in each tributary payload processor.

#### **9.15.2 Incoming Timing Generator**

The incoming timing generator identifies the incoming tributary being processed at any given point in time. Based on the configuration of the VTPP (it can process various mixes of tributary types), the incoming timing generator extracts the STS-1 SPE, VC3, or a single TUG3 from a VC4, and identifies the bytes within these envelopes that correspond to various types of overhead and those that carry specific tributaries to be processed. The H4 byte is identified for the incoming multiframe detector so that it can determine the incoming tributary multiframe boundaries. The identification of specific tributaries allows the pointer interpreter to be time-sliced across the mix of tributaries present in the incoming data stream. The identification of the V1-V3 bytes of VTs, or TUs allows the pointer interpreter to function.

### 9.15.3 Incoming Multiframe Detector

The multiframe alignment sequence in the path overhead H4 byte is monitored for the bit patterns of 00, 01, 10, 11 in the two least significant bits. If an unexpected value is detected, the primary multiframe will be kept, and a second multiframe process will, in parallel, check for a phase shift. The primary process will enter out of multiframe state (OOM). A new multiframe alignment is chosen, and OOM state is exited when four consecutive correct multiframe patterns are detected. Loss of multiframe (LOM) is declared after residing in the OOM state at the ninth H4 byte without re-alignment. In counting to nine, the out of sequence H4 byte that triggered the transition to the OOM state is counted as the first. A new multiframe alignment is chosen, and LOM state is exited when four consecutive correct multiframe patterns are detected. Changes in multiframe alignments are detected and reported.

### 9.15.4 Pointer Interpreter

The pointer interpreter is a time-sliced state machine that can process up to 28 independent tributaries. The state vector is saved in RAM as directed by the incoming timing generator. The pointer interpreter processes the incoming tributary pointers such that all bytes within the tributary synchronous payload envelope can be identified and written into the unique payload first-in first-out buffer for the tributary in question. A marker that tags the V5 byte is passed through the payload buffer. The incoming timing generator directs the pointer interpreter to the correct payload buffer for the tributary being processed.

The pointer interpreter processes the incoming pointers (V1/V2) as specified in the references. The pointer value is used to determine the location of the tributary path overhead byte (V5) in the incoming TUG3 or STS-1 (AU3) stream.

### 9.15.5 Payload Buffer

The payload buffer is a bank of FIFO buffers. It is synchronous in operation and is based on a time-sliced RAM. The three 19.44 MHz clock cycles in each 6.48 MHz period are shared between the read and write operations. The pointer interpreter writes tributary payload data and the V5 tag into the payload buffer. A 16 byte FIFO buffer is provided for each of the (up to 28) tributaries. Address information is also passed through the payload buffer to allow FIFO fill status to be determined by the pointer generator.

### 9.15.6 Outgoing Timing Generator

The outgoing timing generator identifies the outgoing tributary byte being processed. Based on the configuration of the VTPP, the outgoing timing generator effectively constructs the STS-1 SPE, VC3, or VC4, and identifies the bytes within these envelopes that correspond to various types of overhead and bytes that carry specific tributaries. The identification of specific tributaries allows the pointer generator to be time-sliced across the mix of tributaries to be sourced in the outgoing data stream. The identification of the V1-V3 bytes of VTs, or TUs allows the pointer generator to function.

The sequence of H4 bytes is generated by each tributary payload processor and inserted into the outgoing administrative units. The six most significant bits of H4 are set to logic 1. The sequence of the remaining two H4 bits is determined by the multiframe alignment.

### 9.15.7 Pointer Generator

The pointer generator block generates the tributary pointers (V1/V2) as specified in the references. The pointer value is used to determine the location of the tributary path overhead byte (V5) on the outgoing stream.

The pointer generator is a time-sliced state machine that can process up to 28 independent tributaries. The state vector is saved in RAM at the address associated with the current tributary. The pointer generator fills the outgoing tributary synchronous payload envelopes with bytes read from the associated FIFO in the payload buffer for the current tributary. The pointer generator creates pointers in the V1-V3 bytes of the outgoing data stream. The marker that tags the V5 byte that is passed through the payload buffer is used to align the pointer. The outgoing timing generator directs the pointer generator to the FIFO in the payload buffer that is associated with the tributary being processed. The pointer generator monitors the fill levels of the payload buffers and inserts outgoing pointer justifications as necessary to avoid FIFO spillage. Normally, the pointer generator has a FIFO dead band of two bytes. The dead band can be collapse to one so that any incoming pointer justifications will be reflected by a corresponding outgoing justification with no attenuation. Signals are output by the pointer generator that identify outgoing V5 bytes and the tributary synchronous payload envelopes. On a per tributary basis, tributary path AIS and tributary idle (unequipped) can be inserted as controlled by microprocessor accessible registers. The idle code is selectable globally for the entire VC3 or TUG3 to be all-zeros or all-ones. It is also possible to force an inverted new data flag on individual tributaries for the purpose of diagnosing downstream pointer processors. Tributary path AIS is automatically inserted into outgoing tributaries if the pointer interpreter detects tributary path AIS on the corresponding incoming tributary.

## **9.16 Receive Tributary Path Overhead Processor (RTOP)**

The tributary path overhead processor (RTOP) monitors the outgoing stream of the tributary payload processor (VTPP) and processes the tributaries within an STS-1, AU3, or TUG3. The RTOP can be configured to process all the VT1.5s or VT2s that can be carried in an STS-1 or all the TU11s or TU12s that can be carried in an AU3 or TUG3. The number of tributaries managed by each RTOP ranges from 21 (when configured to process all VT2s or all TU12s) to 28 (when configured to process all VT1.5s or all TU11s).

The RTOP provides tributary performance monitoring of incoming tributaries. Bit interleaved parity of the incoming tributaries is computed and compared with the BIP-2 code encoded in the V5 byte of the tributary. Errors between the computed and received values are accumulated. RTOP also accumulates far end block error codes. Incoming path signal label is debounced and compared with the provisioned value. Path signal label unstable, path signal label mismatch and change of path signal label event are identified.

### **9.16.1 Clock Generator**

The clock generator derives a 6.48 MHz clock from the 19.44 MHz system clock and distributes this to the tributary payload processor.

### **9.16.2 Timing Generator**

The timing generator identifies the incoming tributary being processed at any given point in time. Based on the configuration of the RTOP (it can process various mixes of tributary types), the incoming timing generator extracts the STS-1 SPE, VC3, or a single TUG3 from a VC4, and identifies the bytes within these envelopes that correspond to various types of overhead and those that carry specific tributaries to be processed. The identification of specific tributaries allows the error monitor and extract blocks to be time-sliced across the mix of tributaries present in the incoming data stream.

### **9.16.3 Error Monitor**

The error monitor block is a time-sliced state machine. It relies on the timing generator block to identify the tributary being processed. The error monitor block contains a set of 12-bit counters that are used to accumulate tributary path BIP-2 errors, and a set of 11-bit counters to accumulate far end block errors (FEBE). The contents of the counters may be transferred to a holding RAM, and the counters reset under microprocessor control.

Tributary path BIP-2 errors are detected by comparing the tributary path BIP-2 bits in the V5 byte extracted from the current multiframe, to the BIP-2 value computed for the previous multiframe. BIP-2 errors may be accumulated on a block or nibble basis as controlled by software configurable registers. Far end block errors (FEBEs) are detected by extracting the FEBE bit from the tributary path overhead byte (V5).

Tributary path remote defect indication (RDI) and remote failure indication (RFI) are detected by extracting bit 8 and bit 4 respectively of the tributary path overhead byte (V5). The RDI is recognized when bit 8 of the V5 byte is set high for five or ten consecutive multiframes while RFI is recognized when bit 4 of V5 is set high for five or ten consecutive frames. The RDI and RFI bits may be treated as a two-bit code word. A code change is only recognized when the code is unchanged for five or ten frames.

The tributary path signal label (PSL) found in the tributary path overhead byte (V5) is processed. An incoming PSL is accepted when it is received unchanged for five consecutive multiframes. The accepted PSL is compared with the associated provisioned value. The PSL match/mismatch state is determined by the following:

**Table 2 - Path Signal Label Mismatch State**

Expected PSL	Accepted PSL	PSLM State
000	000	Match
000	001	Mismatch
000	PDI Code	Mismatch
000	XXX $\neq$ 000, 001, PDI Code	Mismatch
001	000	Mismatch
001	001	Match
001	PDI Code	Match
001	XXX $\neq$ 000, 001, PDI Code	Match
PDI Code	000	Mismatch
PDI Code	001	Match
PDI Code	PDI Code	Match
PDI Code	XXX $\neq$ 000, 001, PDI Code	Mismatch
XXX $\neq$ 000, 001, PDI Code	000	Mismatch

Expected PSL	Accepted PSL	PSLM State
XXX $\neq$ 000, 001, PDI Code	001	Match
XXX $\neq$ 000, 001, PDI Code	XXX	Match
XXX $\neq$ 000, 001, PDI Code	YYY	Mismatch

Each time an incoming PSL differs from the one in the previous multiframe, the PSL unstable counter is incremented. Thus, a single bit error in the PSL in a sequence of constant PSL values will cause the counter to increment twice, once on the errored PSL and again on the first error-free PSL. The incoming PSL is considered unstable when the counter reaches five. The counter is cleared when the same PSL is received for five consecutive multiframes.

### **9.17 Receive Tributary Demapper (RTDM)**

The Receive Tributary Demapper (RTDM) demaps up to 28 T1 or 21 E1 bit asynchronous mapped signals from an STS-1 SPE, TUG3 within a STM-1/VC4 or STM-1 VC3 payload. The bit asynchronous T1 mapping consists of 104 octets every 500 $\mu$ s (2 KHz) and is shown in Table 3. The bit asynchronous E1 mapping consists of 140 octets every 500 $\mu$ s and is shown in Table 4.

**Table 3 - Asynchronous T1 Tributary mapping**

V5
RRRRRRIR
24 bytes - 8I
J2
C <sub>1</sub> C <sub>2</sub> OOOOIR
24 bytes - 8I
C <sub>1</sub> C <sub>2</sub> OOOOIR
24 bytes - 8I
Z7
C <sub>1</sub> C <sub>2</sub> RRRS <sub>1</sub> S <sub>2</sub> R
24 bytes - 8I

R: Fixed Stuff bit - set to logic '0' or '1'

C: Stuff Control bit - set to logic '1' for stuff indication

S: Stuff Opportunity bit - when stuff control bit is '0', stuff opportunity is 1 bit

O: Overhead

I: T1 payload information

**Table 4 - Asynchronous E1 Tributary Mapping**

V5
R
32 bytes - 8I
R
J2
C <sub>1</sub> C <sub>2</sub> OOOORR
32 bytes - 8I
R
Z6
C <sub>1</sub> C <sub>2</sub> OOOORR
32 bytes - 8I
R
Z7
C <sub>1</sub> C <sub>2</sub> RRRRS <sub>1</sub>
S <sub>2</sub> IIIIII
31 bytes - 8I
R

R: Fixed Stuff bit - set to logic '0' or '1'

C: Stuff Control bit - set to logic '1' for stuff indication

S: Stuff Opportunity bit - when stuff control bit is '0', stuff opportunity is 1 bit

O: Overhead

I: E1 payload information

The RTDM buffers the tributary synchronous payload envelope bytes of the incoming tributaries in individual FIFOs to accommodate tributary pointer justifications.

The RTDM performs majority voting on the tributary stuff control (C1, C2) bits. If the majority of each set of the stuff control bits indicate a stuff operation, then the associated stuff opportunity bit (S1, S2) will not carry T1 or E1 payload. Conversely, if the majority of the stuff control bits indicate a data operation, the appropriate stuff opportunity bit(s) will carry T1 or E1 payload. At each multiframe boundary, the RTDM indicates to the down stream parallel to serial converter (PISO) the status of the stuff control bits. For T1 streams, the parallel to serial converter can be controlled to generate 771, 772 or 773 T1 clock cycles. For E1 streams, the number of clock cycles is controllable to 1023, 1024 or 1025.

The RTDM attenuates jitter introduced by pointer justification events. Tributary payload data is held in a FIFO. When a pointer justification is detected, the RTDM issues evenly spaced commands to the down stream parallel to serial converter block which makes 1/12 UI adjustments to the phase of its generated T1 output clock or 1/9 UI adjustments to the E1 clock. The number of commands sent per incoming pointer justification is based on the observation that four T1 or E1 frames are delivered or deleted for each full round of 104 VT1.5 (TU-11) or 140 VT2 (TU-12) pointer justifications.

### **9.18 Parallel In to Serial Out Converter (PISO)**

The Parallel In to Serial Out Converter (PISO) serializes up to 28 T1 or 21 E1 tributaries which have been demapped from the STS-1 SPE or STM-1AU3 or VC3 via the Receive Tributary Demapper (RTDM). In conjunction with the Receive Tributary Demapper (RTDM) this block performs the desynchronizer function to provide a low jitter T1 or E1 serial clock and data.

The Desynchronizer uses a combination of two clock generation techniques to desynchronize the demapped T1s and E1s. Incoming bit stuff events cause an extra bit of data to be generated or removed from the generated serial stream over the following 2KHz multi-frame. Pointer justifications are spread out by advancing or retarding the generated T1 or E1 clock phase.

The 19.44MHz LREFCLK input is used to generate a nominal 1.544Mb/s or 2.048Mb/s clock over a 2KHz interval as indicated by the LDC1J1V1 input divided by four. A nominal T1 rate consists of 772 clocks in 500us. A nominal E1 rate consists of 1024 clocks in 500us. Stuff events, as indicated by the RTDM block, are compensated within the desynchronizer by generating three separate clocks to construct the faster or slower rate as shown in Table 5.

A mixture of T1 clock cycles is generated using 12 REFCLK cycles (Fast T1 Cycles) and 13 REFCLK cycles (Slow T1 Cycles) to produce an overall rate of 1.544MHz over the 500us period. A mixture of E1 clock cycles is generated using 9 REFCLK cycles (Fast E1 cycles) and 10 REFCLK cycles (Slow E1 cycles) to produce an overall rate of 2.048MHz over the 500us period. Table 5 shows the number of fast and slow cycles required to generate all three T1 and E1 rates.

**Table 5 - Desynchronizer Clock Generation Algorithm**

Clock Rate	Fast T1 Cycles	Slow T1 Cycles	Overall T1 Cycles	Fast E1 Cycles	Slow E1 Cycles	Overall E1 Cycles
Slow	303	468	771	510	513	1023
Nominal	316	456	772	520	504	1024
Fast	329	444	773	530	495	1025

Pointer justification events, as indicated by the RTDM block, are compensated within the desynchronizer by advancing or retarding the phase of the generated fast, slow and nominal clocks during the 2KHz period. Because pointer justification have a limited frequency of occurrence the phase adjustments are leaked out slowly. Twelve phase adjustments will remove or add an entire T1 clock whereas nine phase adjustments will remove or add an entire E1 clock. The number of phase adjustments needed per pointer justification is on average 89.077 for T1 or 65.829 for E1. These pointer adjustments are spread out over a 1 second period.

### **9.19 DS3 Mapper Drop Side (D3MD)**

The DS3 Mapper DROP Side (D3MD) block demaps a DS3 signal from an STS-1 (STM-0/AU3) payload. The asynchronous DS3 mapping consists of 9 rows every 125  $\mu$ s (8 KHz). Each row contains 621 information bits, 5 stuff control bits, 1 stuff opportunity bit, and 2 overhead communication channel bits. Fixed stuff bytes are used to fill the remaining bytes. The asynchronous DS3 mapping is shown in Table 6.

**Table 6 - Asynchronous DS3 mapping to STS-1 (STM-0/AU3)**

J1	2 x 8R	RRCIIIII	25 x 8I	2 x 8R	CCRRRRRR	26 x 8I	2 x 8R	CCRROORS	26 x 8I
	2 x 8R	RRCIIIII	25 x 8I	2 x 8R	CCRRRRRR	26 x 8I	2 x 8R	CCRROORS	26 x 8I
	2 x 8R	RRCIIIII	25 x 8I	2 x 8R	CCRRRRRR	26 x 8I	2 x 8R	CCRROORS	26 x 8I
STS	2 x 8R	RRCIIIII	25 x 8I	2 x 8R	CCRRRRRR	26 x 8I	2 x 8R	CCRROORS	26 x 8I
POH	2 x 8R	RRCIIIII	25 x 8I	2 x 8R	CCRRRRRR	26 x 8I	2 x 8R	CCRROORS	26 x 8I

J1	2 x 8R	RRCIIIII	25 x 8I	2 x 8R	CCRRRRRR	26 x 8I	2 x 8R	CCRROORS	26 x 8I
	2 x 8R	RRCIIIII	25 x 8I	2 x 8R	CCRRRRRR	26 x 8I	2 x 8R	CCRROORS	26 x 8I
	2 x 8R	RRCIIIII	25 x 8I	2 x 8R	CCRRRRRR	26 x 8I	2 x 8R	CCRROORS	26 x 8I
	2 x 8R	RRCIIIII	25 x 8I	2 x 8R	CCRRRRRR	26 x 8I	2 x 8R	CCRROORS	26 x 8I
	2 x 8R	RRCIIIII	25 x 8I	2 x 8R	CCRRRRRR	26 x 8I	2 x 8R	CCRROORS	26 x 8I

R: Fixed Stuff bit - set to logic '0' or '1'

C: Stuff Control bit - set to logic '1' for stuff indication

S: Stuff Opportunity bit - when stuff control bit is '0', stuff opportunity is 1 bit

O: Overhead communication channel

I: DS3 payload information

### 9.19.1 DS3 Demapper

The D3MD performs majority vote on the received C-bits. If 3 out of 5 C-bits are '1's, the associated S bit is interpreted as a stuff bit. If 3 out of 5 C-bits are '0's, the associated S bit is interpreted as an Information bit. The information bits are written to an elastic store and the Fixed Stuff bits (R) are ignored.

Given a path signal label mismatch (PSLM) or path signal label unstable (PSLU), the D3MD ignores the STS-1 (STM-0/AU3) SPE and writes a DS3 AIS pattern to the elastic store. In addition, the desynchronization algorithm assumes a nominal ratio of data to stuff bits carried in the S bits (1 out of 3 S bits is assumed to be an information (data) bit). DS3 AIS is shown in Table 7.

**Table 7 - DS3 AIS format.**

X (1)	D	F (1)	D	C (0)	D	F (0)	D	C (0)	D	F (0)	D	C (0)	D	F (1)	D
X (1)	D	F (1)	D	C (0)	D	F (0)	D	C (0)	D	F (0)	D	C (0)	D	F (1)	D
P (p)	D	F (1)	D	C (0)	D	F (0)	D	C (0)	D	F (0)	D	C (0)	D	F (1)	D
P (p)	D	F (1)	D	C (0)	D	F (0)	D	C (0)	D	F (0)	D	C (0)	D	F (1)	D
M (0)	D	F (1)	D	C (0)	D	F (0)	D	C (0)	D	F (0)	D	C (0)	D	F (1)	D
M (1)	D	F (1)	D	C (0)	D	F (0)	D	C (0)	D	F (0)	D	C (0)	D	F (1)	D
M (0)	D	F (1)	D	C (0)	D	F (0)	D	C (0)	D	F (0)	D	C (0)	D	F (1)	D

- valid M-frame alignment bits (M-bits), M-subframe alignment bits (F-bits), and parity bit of the preceding M-frame (P-bits). The two P-bits are identical, either both are zeros or ones.
- all the C-bits in the M-frame are set to zeros
- the X-bits are set to ones
- the information bit (84 Data bits with repeating sequence of 1010..)

### 9.19.2 DS3 Demapper Elastic Store

The elastic store block is provided to compensate for frequency differences between the DS-3 stream extracted from the STS-1 (STM-0/AU3) SPE and the incoming CLK52M. The DS3 Demapper extracts I bits from the STS-1 (STM-0/AU3) SPE and writes the bits into a 128 bit (16 byte) elastic store. Eight bytes are provided for SONET/SDH overhead (3 bytes for TOH, 1 byte for a positive stuff, 1 byte for POH) and DS3 reserve stuffing bits (2 bytes for R bits, and 3 overhead bits which is rounded-up to 1 byte). The remaining 8 bytes are provided for path pointer adjustments.

Data is read out of the Elastic Store using a divide by 8 version of the input CLK52M clock. If an overflow or underflow condition occurs, an interrupt is optionally asserted and the Elastic Store read and write address are reset to the startup values (logically 180 degrees apart).

### 9.19.3 DS3 Desynchronizer

The Desynchronizer monitors the Elastic Store level to control the de-stuffing algorithm to avoid overflow and underflow conditions. The Desynchronizer assumes either a 51.84 MHz clock (provided internally) or a 44.928 MHz clock (provided via input CLK52M).

When using a 44.928 MHz CLK52M clock, the DS3 clock is generated using a fixed 8 KHz interval. The 8KHz interval is subdivided into 9 rows. Each row contains either 621 or 622 clock periods. The DS3RICK contains 624 pulses at 72KHz (9\*8KHZ). To generate 621 pulses, a gap pattern of 207 clocks + 1 clock gap + 207 clocks + 1 clock gap + 207 clocks + 1 clock gap is used. To generate 622 pulses, a gap pattern of 207 clocks + 1 clock gap + 207 clocks + 1 clock gap + 208 clocks is used.

When using a 51.84 MHz CLK52M clock, the DS3 clock is generated using similar gapping patterns. To generate 621 pulses per row, a gapping pattern of  $63 * (7 \text{ clocks} + 1 \text{ clock gap}) + 36 * (5 \text{ clocks} + 1 \text{ clock gap})$  is used. To generate

622 pulses per row, a gapping pattern of  $63 * (7 \text{ clocks} + 1 \text{ clock gap}) + 35 * (5 \text{ clocks} + 1 \text{ clock gap}) + 6 \text{ clocks}$  is used.

Table 8 illustrates the gap patterns used to generate the desynchronized DS3 clock under the normal, DS3 AIS, faster and slower status. The faster pattern is used to drain the elastic store to avoid overflows. The slower pattern is used to allow the elastic store to fill to avoid underflows.

**Table 8 - DS3 desynchronizer clock gapping algorithm.**

Row Number	Normal or DS3 AIS	Run Faster	Run Slower
1	621	621	621
2	621	621	621
3	622	622	622
4	621	621	621
5	621	622	621
6	622	622	621
7	621	621	621
8	621	622	621
9	622	622	621

## **9.20 Transmit Tributary Path Overhead Processor (TTOP)**

The Transmit Tributary Path Overhead Processor (TTOP) generates the path overhead for up to 28 VT1.5/TU-11s or 21 VT2/TU-12s.

When configured for SONET compatible operation, the TTOP inserts the four tributary path overhead bytes (V5, J2, Z6, and Z7) to each tributary. The TTOP may also be configured for SDH compatible operation. The incoming STM-1 stream may carry three AU3s or an AU4 with three TUG3s.

The TTOP computes the BIP-2 code in the current tributary SPE and inserts the result into the BIP-2 bits of the V5 byte in the next tributary SPE. The tributary path signal label in the V5 byte of each tributary can be sourced from internal registers. The tributary far end block error bit in the V5 byte of each tributary is inserted based on the BIP error count detected at a companion RTOP TSB. The tributary remote failure indication and remote defect indication bits in the V5 or the Z7 byte of each tributary is inserted based on the tributary alarm status of the companion Tributary Remote Alarm Processor, TRAP, TSB.

The TTOP inserts the tributary trail trace identifier into the J2 byte. Each tributary is provided with a 64-byte buffer to store the identifier. One shadow buffer is available for temporary replacement of a selected transmitted TTI while the 64-byte identifier buffer is being updated. Data is retrieved sequentially from the active buffer at each J2 byte position. The shadow buffer can be programmed with new messages without timing constraints when inactive. An inactive 64-byte identifier buffer can also be programmed with new messages

without timing constraints. Programming for TTI buffers is done one buffer at a time by first programming the shadow buffer, switching to the shadow buffer for the desired tributary, updating the desired tributary identifier buffer and finally switching back from the shadow buffer to the tributary buffer. Switching between the shadow buffer and normal buffer is synchronized to the start of each identifier on a per-tributary basis.

### **9.21 Transmit Remote Alarm Processor (TRAP)**

When configured for SONET compatible operation, the TRAP SONET/SDH Transmit Remote Alarm Processor processes remote alarm indications of tributaries in an STS-3 stream. The virtual tributaries within an STS-1 stream may be configured to accept either VT1.5 or VT2 tributary types. The TRAP may also be configured for SDH compatible operation. The incoming STM-1 stream may carry three AU3s or an AU4 with three TUG3s.

The TRAP may be configured to extract tributary remote defect indications (RDI-V) and tributary remote error indications (REI-V) from a remote parallel alarm stream received on the drop telecom bus, LDDATA[7:0]. Remote error indications are accumulated and reported at the V5 byte of the associated tributary in the outgoing data stream. In extended RDI mode, both remote defect indications and auxiliary remote defect indications detected on the receive telecom drop bus are enabled for insertion on to the transmit telecom add bus via the TTOP block. When the remote defect indication and auxiliary remote defect indication returns to 'b00 from other states, the last state on RDI and RFI indications to the TTOP block are maintained such as to ensure that it has been reported for at least 10 multiframes. When configured for out of extended RDI mode, the content of the received remote defect indication is reported to the TTOP block and the auxiliary remote defect indication is ignored. Once the RDI indication to the TTOP block is set high, it will be maintained high for at least 10 multiframes before returning to low. In both cases any particular value of RDI will be sent for at least 10 multiframes before changing.

Alternatively, the TRAP may also be configured to extract RDI-V and REI-V from two independent serial remote alarm ports, RADEAST and RADWEST. Remote error indications are accumulated and reported at the V5 byte of the associated tributary in the outgoing data stream. When the associated tributary is configured for extended RDI operation, the RDI and RFI timeslots are taken as a two bit code point. When the associated tributary is configured for extended RFI operation, the RDI and RFI timeslots are taken as a two bit code point. The content of the RDI timeslot is reported on the RDI indication to the TTOP block while the content of the RFI timeslot is reported on the RFI indication to the TTOP block. When RDI and RFI timeslots return to 'b00 from other states, the last state on RDI and RFI indications to TTOP are maintained such as to ensure that it has been reported for at least 10 multiframes. When the associated

tributary is not in extended RDI mode, the content of the RDI timeslot is reported on the RDI indication and the RFI timeslot is ignored. Once the RDI indication is set high, it will be maintained high for at least 10 multiframes before returning to low. In both cases any particular value of RDI will be sent for at least 10 multiframes before changing.

The TRAP provides selection between the remote parallel alarm port and the two remote serial alarm ports for the source of remote alarm status on a per-tributary basis. Tributaries in any of the three sources of remote alarms can be mapped to arbitrary tributaries in the outgoing data stream.

## **9.22 Transmit Tributary Mapper (TTMP)**

The Transmit Tributary Mapper block bit asynchronously maps up to 28 T1 or 21 E1 streams into an STS-1 SPE, TUG3 in a STM-1/VC4 or STM-1/VC3 payload. The TTMP compensates for any frequency differences between the incoming individual serial bit rates and the available STS-1 or STM-1/VC3 payload capacity. The asynchronous T1 mapping consists of 104 octets every 500  $\mu$ s (2 KHz). The asynchronous E1 mapping consists of 140 octets every 500  $\mu$ s (2 KHz). Refer to the RTDM block for a description of the asynchronous T1 and E1 mappings.

The tributary mapper is a time-sliced state machine which uses a payload buffer as an elastic store. The T1 or E1 streams are read from the payload buffer, and mapped into VT1.5 Payloads and VT2 Payloads using bit asynchronous mapping only.

The Tributary Mapper compensates for phase and frequency offsets using bit stuffing. A jitter-reducing control loop is used to monitor the Payload Buffer depth and reduce mapping jitter to 1.0 UI. To reduce mapping jitter even further, a dither technique is inserted between the control loop and the stuff bit generator resulting in an acceptable desynchronizer mapping jitter of about 0.3 UI.

The Tributary Mapper may optionally act as a time switch. When Time Switch Enable is active, the association of Tributary Mapper VT Payloads to logical FIFO data streams is software configurable. There are two pages in the time switch configuration RAM. One page is software selectable to be the active page and the other the stand-by page. The configuration in the active page is used to associate outgoing VT Payloads to logical FIFOs. The stand-by page can be programmed to the next switch configuration. Change of page selection is synchronized to incoming stream frame boundaries. When Time Switch Enable is inactive, the association of outgoing VT Payloads to logical FIFOs is fixed.

The TTMP outputs the STS-1, TUG3 in a STM-1/VC4 or STM-1/VC3 with the bit asynchronous mapped T1s or E1s onto an internal bus for further processing by the Transmit Tributary Payload Processor block.

### **9.23 Serial In to Parallel Out Converter (SIPO)**

The Serial In to Parallel Out Converter (SIPO) accepts serial data from up to 28 T1 or 21 E1 sources and converts these streams to byte serial format. The bytes are passed to the Transmit Tributary Mapper (TTMP) for bit asynchronous mapping into the STS-1.

### **9.24 DS3 Mapper ADD Side (D3MA)**

The DS3 Mapper ADD Side (D3MA) block maps a DS3 signal into an STS-1 (STM-0/AU3) payload and compensate for any frequency differences between the incoming DS3 serial bit rate (TICLK) and the available STS-1 (STM-0/AU3) SPE mapped payload capacity. The asynchronous DS3 mapping consists of 9 rows every 125  $\mu$ s (8 KHz). Each row contains 621 information bits, 5 stuff control bits, 1 stuff opportunity bit, and 2 overhead communication channel bits. Fixed stuff bytes are used to fill the remaining bytes. Please refer to section 9.19 for a description of the DS3 mapping.

#### **9.24.1 DS3 Mapper Serializer**

High speed serial data from the DS3-TRAN block is deserialized and written into the Elastic Store.

#### **9.24.2 DS3 Mapper Elastic Store**

The elastic store block is provided to compensate for frequency differences between the DS3 stream from the DS3-TRAN block and the STS-1 (STM-0/AU3) SPE capacity. The DS3 Serializer writes data into the elastic store at the TICLK/8 rate while data is read out at the stuffed STS-1 (STM-0/AU3) byte rate. If an overflow or underflow condition occurs, an interrupt is optionally asserted and the Elastic Store read and write address are reset to the startup values (logically 180 degrees apart).

The Elastic store is 128 bits (16 bytes) to allow for a fixed read/write pointer lag of 7 bytes (3 bytes for TOH, 1 byte for POH, 2 bytes for R bits, and 3 overhead bits which is rounded-up to 1 byte). Four bytes are also added on either side for positive and negative threshold detection.

### 9.24.3 DS3 Synchronizer

The DS3 Synchronizer performs the mapping of the DS3 into the STS-1 (STM-0/AU3) SPE. The DS3 Synchronizer monitors the Elastic Store level to control the stuffing algorithm to avoid overflow (i.e. run faster) and underflow (i.e. run slower) conditions. The fill level of the elastic store is monitored and stuff opportunities in the DS3 mapping are used to center the Elastic Store. To consume a stuff opportunity, the five C-bits on a row are set to ones and the S bit is used to carry an DS3 information bit. When the S bit is not used to carry information, the C-bits on the row are set to zeros.

The DS3 synchronizer uses a fixed bit leaking algorithm which leaks 8 bits of phase buildup in 500  $\mu$ s. The 8kHz STS-1 (STM-0/AU3) frame interval is subdivided into 9 rows. Each row contains one stuff opportunity. Table 9 illustrates the stuffing implementation where S means stuff bit and I means an information bit (DS3 data).

**Table 9 - DS3 synchronizer bit stuffing algorithm.**

Row Number	Normal or DS3 AIS	Run Faster	Run Slower
1	S	S	S
2	S	S	S
3	I	I	I
4	S	S	S
5	S	I	S
6	I	I	S
7	S	S	S
8	S	I	S
9	I	I	S

Under microprocessor control, the incoming DS3 stream can be overwritten with the framed DS3 AIS. When asserting DS3 AIS, a nominal stuff pattern is used as illustrated above. Please refer to the D3MD functional description section for a description of the DS3 AIS frame.

The D3MA outputs the STS-1 (STM-0/AU3) with the mapped DS3 onto the Line Add bus, LADATA[7:0].

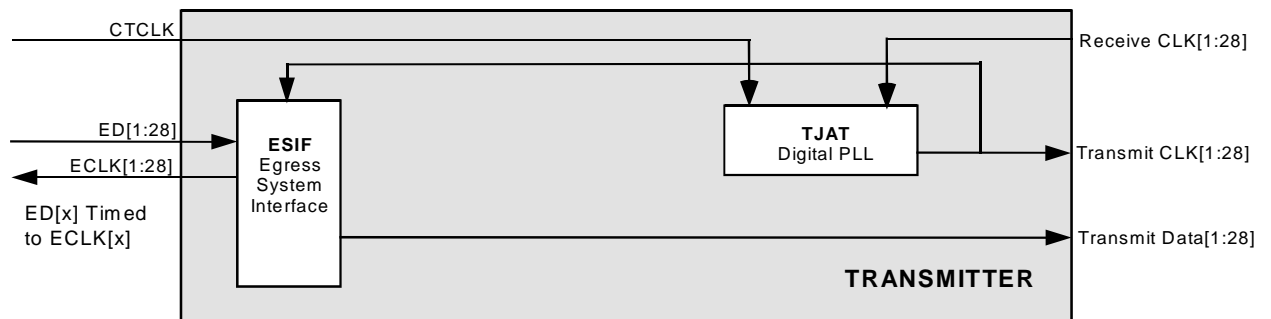
## 9.25 Egress System Interface (ESIF)

The Egress System Interface (ESIF) block provides system side serial clock and data access for up to 28 T1 or 21 E1 transmit streams. Control of the system side interface is global to TEMAP and is selected through the SYSOPT[2:0] bits in the Global Configuration register at address 0001H. The system interface options are serial clock and data or SBI bus.

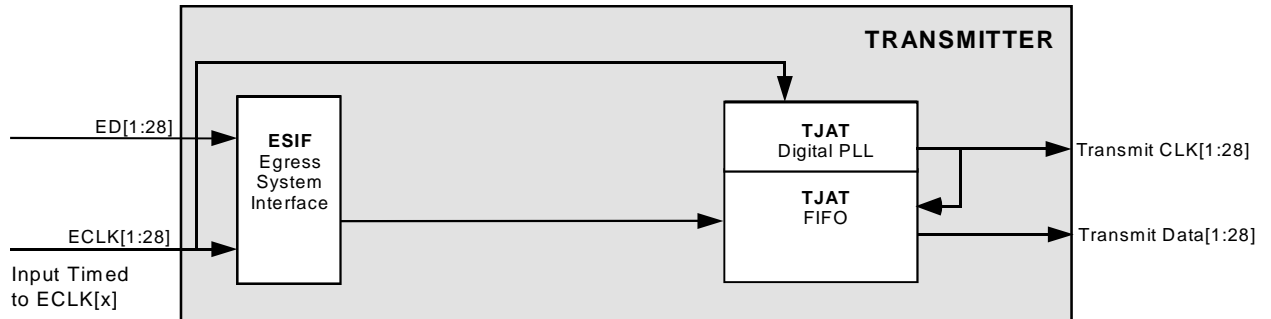
There are two serial clock and data egress interface modes provided by TEMAP, Clock Master: Clear Channel and Clock Slave: Clear Channel. The egress serial clock and data interface clocking modes are selected via the EMODE[2:0] bits in the T1/E1 Egress Serial Interface Mode Select register.

In all egress Clock Master modes the transmit clock can be sourced from either the common transmit clock, CTCLK, one of the two recovered clocks, RECVCLK1 and RECVCLK2, or the received clock for that link. The selection between CTCLK, RECVCLK1 and RECVCLK2 as the reference transmit clock is the same for all T1/E1 framers. Jitter attenuation can be applied to the master mode clock with the TJAT.

**Figure 14 - Clock Master: Clear Channel**



In Clock Master: Clear Channel mode, ECLK[x] is a continuous clock at 1.544Mb/s for T1 links or 2.048Mb/s for E1 links.

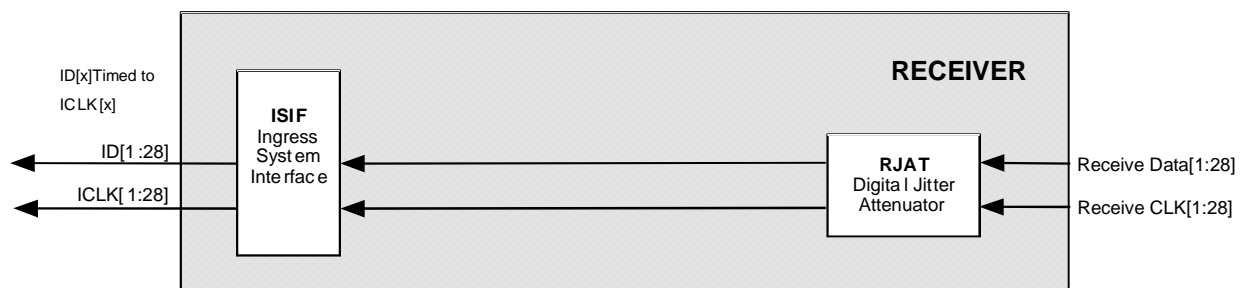
**Figure 15 - Clock Slave: Clear Channel**


In Clock Slave: Clear Channel mode, the egress interface is clocked by the externally provided egress clock, ECLK[x]. ECLK[x] must be a 1.544 MHz clock for T1 links or a 2.048 MHz clock for E1 links. In this mode the T1/E1 framers are bypassed except for the TJAT which may or may not be bypassed depending on the setting of the TJATBYP bit in the T1/E1 Egress Line Interface Options register. Typically the TJAT would be bypassed unless jitter attenuation is required on ECLK[x].

## 9.26 Ingress System Interface (ISIF)

The Ingress System Interface (ISIF) block provides a system side Clock Master serial clock and data access for up to 28 T1 or 21 E1 clear channel receive streams. Control of the system side interface is global to TEMAP and is selected through the SYSOPT[2:0] bits in the Global Configuration register at address 0001H. The system interface options are serial clock and data or SBI bus.

The ingress Clock Master: Clear Channel interface mode is selected via the IMODE[1:0] bits in the T1/E1 Ingress Serial Interface Mode Select register.

**Figure 16 - Clock Master: Clear Channel**


In Clock Master: Clear Channel mode, the elastic store is bypassed and the ingress clock (ICLK[x]) is a jitter attenuated version of the 1.544 MHz or 2.048

MHz receive clock coming from either the M13 multiplex or SONET/SDH demapper. The ingress data appears on ID[x] which no frame alignment indication.

### **9.27 Extract Scaleable Bandwidth Interconnect (EXSBI)**

The Extract Scaleable Bandwidth Interconnect block demaps up to 28 1.544Mb/s links, 21 2.048Mb/s links or a single 44.736Mb/s link from the SBI shared bus. The 44.736Mb/s link can be unframed for mapping into SONET/SDH or it can be DS3 unchannelized when the TEMAP is used as a DS3 framer.

All egress links extracted from the SBI bus can be timed from the source or from the TEMAP. When Timing is from the source the EXSBI commands the PISO to generate 1.544Mb/s, 2.048Mb/s or 44.736Mb/s clocks slaved to the arrival rate of the data or from timing link rate adjustments provided from the source and carried with the links over the SBI bus. The 1.544Mb/s clock is synthesized from the 19.44MHz reference clock, SREFCLK, by dividing the clock by either 12 or 13 in a fixed sequence that produces the nominal 1.544Mb/s rate. The 2.048Mb/s clock is synthesized from the 19.44MHz reference clock by dividing the clock by either 9 or 10 in a fixed sequence that produces the nominal 2.048Mb/s rate. Timing adjustments are made over 500uS intervals and are done by either advancing or retarding the phase or by adding or deleting a whole 1.544Mb/s or 2.048Mb/s clock cycle over the 500uS period.

The 44.736Mb/s clock is synthesized from the 51.84MHz or 44.928MHz reference clock, CLK52M. Using either reference clock frequency, the 44.736Mb/s rate is generated by gapping the reference clock in a fixed way. Timing adjustments are performed by adding or deleting four clocks over the 500uS period.

When the TEMAP is the SBI egress clock master for a link, clocks are sourced within the TEMAP. Based on buffer fill levels, the EXSBI sends link rate adjustment commands to the link source indicating that it should send one additional or one fewer bytes of data during the next 500uS interval. Failure of the source to respond to these commands will ultimately result in overflows or underflows which can be configured to generate per link interrupts.

### **9.28 Insert Scaleable Bandwidth Interconnect (INSBI)**

The Insert Scaleable Bandwidth Interconnect block maps up to 28 1.544Mb/s links, 21 2.048Mb/s links or a single 44.736Mb/s link into the SBI shared bus. The 44.736Mb/s link can be unframed when sourced directly from the DS3 interface or from the DS3 mapper. The 44.736Mb/s link can be an unchannelized DS3 when sourced from the DS3 framer.

Links inserted into the SBI bus are timed from the TEMAP. The INSBI makes link rate adjustments by adding or deleting an extra byte of data over a 500uS interval based on buffer fill levels. Timing adjustments are detected by the receiving SBI interface by explicit signals in the SBI bus structure.

The INSBI optionally sends link rate information across the SBI bus. This information is used by the receiving SBI device to create a recovered link clock which is based on small clock phase adjustments signaled by the INSBI.

### **9.29 Scaleable Bandwidth Interconnect PISO (SBIPISO)**

The Scaleable Bandwidth Interconnect Parallel to Serial converter (SBIPISO) generates up to 28 T1s, 21 E1s or a DS3 serial clock and data signals from the byte serial stream provided by the Extract SBI block. The generated clock rate can be controlled with commands from the EXSBI. In clock slave mode the generated clock will be increased or decreased in small increments based on FIFO fill levels within the EXSBI or directly with clock rate commands from the far end device who is mastering the clock across the SBI bus. In clock master mode the SBIPISO controls the bit rate by accepting data from the EXSBI at the rate of the individual T1, E1 or DS3 clocks sourced into it.

### **9.30 Scaleable Bandwidth Interconnect SIPO (SBISIPO)**

The Scaleable Bandwidth Interconnect Serial to Parallel converter (SBISIPO) sinks up to 28 T1s, 21 E1s or a DS3 serial clock and data signals and generates a byte serial stream to the Insert SBI block. The SBISIPO measures the serial clock against the SBI reference clock and sends this information to the INSBI block and in turn across the SBI bus to the clock generation slave, SBIPISO. In this way an accurate representation of the input clock rate is communicated across the SBI bus.

### **9.31 JTAG Test Access Port**

The JTAG Test Access Port block provides JTAG support for boundary scan. The standard JTAG EXTEST, SAMPLE, BYPASS, IDCODE and STCTEST instructions are supported. The TEMAP identification code is 053650CD hexadecimal.

### **9.32 Microprocessor Interface**

The Microprocessor Interface Block provides normal and test mode registers, the interrupt logic, and the logic required to connect to the Microprocessor Interface. The normal mode registers are required for normal operation, and test mode registers are used to enhance the testability of the TEMAP.

The Register Memory Map in Table 10 shows where the normal mode registers are accessed. The registers are organized so that backward software compatibility with existing PMC devices is optimized. The resulting register organization splits into sections: Master configuration registers, 28 sets of T1/E1 Framer registers, DS3 M13 multiplexing registers, SONET/SDH mapping registers and SBI registers.

On power up reset the TEMAP defaults to 28 T1 framers multiplexed into the M13 multiplexer using the DS3 M23 multiplex format. For proper operation some register configuration is necessary. System side access defaults to the SBI bus without any tributaries enabled which will leave the SBI Drop bus tristated. By default interrupts will not be enabled, automatic alarm generation is disabled, a dual rail DS3 LIU interface is expected and an external transmit reference clock is required.

**Table 10 - Register Memory Map**

Address	Register
0000H	Global Reset
0001H	Global Configuration
0002H	Revision/Global PMON Update
0003H	Master Recovered Clock#1/Reference Clock Select
0004H	Recovered Clock#2 Select
0005H	Master Common Egress Serial and H-MVIP Interface Configuration
0006H	Master Common Ingress Serial and H-MVIP Interface Configuration
0007H-000FH	Reserved
00010H	Master Clock Monitor #1
0011H	Master Clock Monitor #2
0012H	Master Clock Monitor #3
0013H	Master Clock Monitor #4
0014H	Master Clock Monitor #5
0015H-001FH	Reserved

Address	Register
0020H	Master Interrupt Source
0021H	Master Interrupt Status T1/E1 #1-8
0022H	Master Interrupt Status T1/E1 #9-16
0023H	Master Interrupt Status T1/E1 #17-24
0024H	Master Interrupt Status T1 #25-28
0025H	Master Interrupt Status SDH
0026H	Master Interrupt Status Source SBI
0027H	Reserved
0028H	Master Interrupt Status DS3
0029H	Master Interrupt Status DS2
002AH	Master Interrupt Status MX12
002BH	Reserved
002CH	Master SBIDET0 Collision Detect LSB
002DH	Master SBIDET0 Collision Detect MSB
002EH	Master SBIDET1 Collision Detect LSB
002FH	Master SBIDET1 Collision Detect MSB
0030H- 007FH	Reserved
<b>0080H- 00FFH</b>	<b>T1/E1 PMON #1</b>
0080H	T1/E1 Master Configuration
0081H	Reserved
0082H	T1/E1 Receive Options
0083H	T1/E1 Alarm Configuration
0084H	T1/E1 Egress Line Interface Configuration
0085H	T1/E1 Master Ingress Serial Interface Mode Select
0086H	T1/E1 Master Egress Serial Interface Mode Select
0087H	T1/E1 Master Ingress Parity and Alarm Enable
0088H	T1/E1 Master Egress Parity Enable

<b>Address</b>	<b>Register</b>
0089H	T1/E1 Master Serial Interface Configuration
008AH	T1/E1 Transmit Framing and Bypass Options
008BH	T1/E1 Interrupt Source #1
008CH	T1/E1 Interrupt Source #2
008DH	T1/E1 Diagnostics
008EH	T1/E1 PRBS Positioning and HDLC Control
008FH	Reserved
0090H	RJAT Interrupt Status
0091H	RJAT Reference Clock Divisor N1 Control
0092H	RJAT Output Clock Divisor N2 Control
0093H	RJAT Configuration
0094H	TJAT Interrupt Status
0095H	TJAT Reference Clock Divisor N1 Control
0096H	TJAT Output Clock Divisor N2 Control
0097H	TJAT Configuration
0098H- 00B7H	Reserved
00B8H	PMON Interrupt Enable/Status
00B9H	PMON Framing Bit Error Count
00BAH	PMON OOF/COFA/Far End Block Error Count (LSB)
00BBH	PMON OOF/COFA/Far End Block Error Count (MSB)
00BCH	PMON Bit Error/CRCE Count (LSB)
00BDH	PMON Bit Error/CRCE Count (MSB)
00BEH	PMON Reserved
00BFH	PMON Reserved
00C0H- 00CFH	Reserved
00D0H	PRBS Generator/Checker Control
00D1H	PRBS Checker Interrupt Enable/Status

Address	Register
00D2H	PRBS Pattern Select
00D3H	PRBS Reserved
00D4H	PRBS Error Count Register #1
00D5H	PRBS Error Count Register #2
00D6H	PRBS Error Count Register #3
00D7H	PRBS Reserved
00D8H- 00DFH	Reserved
00E0H	T1 ALMI Configuration
00E1H	T1 ALMI Interrupt Enable
00E2H	T1 ALMI Interrupt Status
00E3H	T1 ALMI Alarm Detection Status
00E4H- 00EBH	Reserved
00ECH	T1 FRMR Configuration
00EDH	T1 FRMR Interrupt Enable
00EEH	T1 FRMR Interrupt Status
00EFH	T1 FRMR Reserved
00F0H- 00FFH	Reserved
00E0H	E1 FRMR Frame Alignment Options
00E1H	E1 FRMR Maintenance Mode Options
00E2H	E1 FRMR Framing Status Interrupt Enable
00E3H	E1 FRMR Maintenance/Alarm Status Interrupt Enable
00E4H	E1 FRMR Framing Status Interrupt Indication
00E5H	E1 FRMR Maintenance/Alarm Status Interrupt Indication
00E6H	E1 FRMR Framing Status
00E7H	E1 FRMR Maintenance/Alarm Status
00E8H	E1 FRMR International/National Bits

<b>Address</b>	<b>Register</b>
00E9H	E1 FRMR CRC Error Count - LSB
00EAH	E1 FRMR CRC Error Count - MSB
00EBH	E1 FRMR National Bit Codeword Interrupt Enables
00ECH	E1 FRMR National Bit Codeword Interrupts
00EDH	E1 FRMR National Bit Codewords
00EEH	E1 FRMR Frame Pulse/Alarm Interrupt Enables
00EFH	E1 FRMR Frame Pulse/Alarm Interrupt
00F0H- 00FFH	Reserved
<b>0100H- 017FH</b>	<b>T1/E1 PMON #2</b>
<b>0180H- 01FFH</b>	<b>T1/E1 PMON #3</b>
<b>0200H- 027FH</b>	<b>T1/E1 PMON #4</b>
<b>0280H- 02FFH</b>	<b>T1/E1 PMON #5</b>
<b>0300H- 037FH</b>	<b>T1/E1 PMON #6</b>
<b>0380H- 03FFH</b>	<b>T1/E1 PMON #7</b>
<b>0400H- 047FH</b>	<b>T1/E1 PMON #8</b>
<b>0480H- 04FFH</b>	<b>T1/E1 PMON #9</b>
<b>0500H- 057FH</b>	<b>T1/E1 PMON #10</b>
<b>0580H- 05FFH</b>	<b>T1/E1 PMON #11</b>
<b>0600H- 067FH</b>	<b>T1/E1 PMON #12</b>

Address	Register
<b>0680H-06FFH</b>	<b>T1/E1 PMON #13</b>
<b>0700H-077FH</b>	<b>T1/E1 PMON #14</b>
<b>0780H-07FFH</b>	<b>T1/E1 PMON #15</b>
<b>0800H-087FH</b>	<b>T1/E1 PMON #16</b>
<b>0880H-08FFH</b>	<b>T1/E1 PMON #17</b>
<b>0900H-097FH</b>	<b>T1/E1 PMON #18</b>
<b>0980H-09FFH</b>	<b>T1/E1 PMON #19</b>
<b>0A00H-0A7FH</b>	<b>T1/E1 PMON #20</b>
<b>0A80H-0AFFH</b>	<b>T1/E1 PMON #21</b>
<b>0B00H-0B7FH</b>	<b>T1 PMON #22</b>
0B00H	T1/E1 Master Configuration
0B01H	Reserved
0B02H	T1/E1 Receive Options
0B03H	T1/E1 Ingress Line Interface Configuration
0B04H	T1/E1 Egress Line Interface Configuration
0B05H	T1/E1 Master Ingress Serial Interface Mode Select
0B06H	T1/E1 Master Egress Serial Interface Mode Select
0B07H	T1/E1 Master Ingress Parity and Alarm Enable
0B08H	T1/E1 Master Egress Parity Enable
0B09H	T1/E1 Master Serial Interface Configuration
0B0AH	T1/E1 Transmit Framing and Bypass Options

Address	Register
0B0BH	T1/E1 Interrupt Source #1
0B0CH	T1/E1 Interrupt Source #2
0B0DH	T1/E1 Diagnostics
0B0EH	T1/E1 PRBS Positioning and HDLC Control
0B0FH	Reserved
0B10H	RJAT Interrupt Status
0B11H	RJAT Reference Clock Divisor N1 Control
0B12H	RJAT Output Clock Divisor N2 Control
0B13H	RJAT Configuration
0B14H	TJAT Interrupt Status
0B15H	TJAT Reference Clock Divisor N1 Control
0B16H	TJAT Output Clock Divisor N2 Control
0B17H	TJAT Configuration
0B18H- 0B37H	Reserved
0B38H	PMON Interrupt Enable/Status
0B39H	PMON Framing Bit Error Count
0B3AH	PMON OOF/COFA/Far End Block Error Count (LSB)
0B3BH	PMON OOF/COFA/Far End Block Error Count (MSB)
0B3CH	PMON Bit Error/CRCE Count (LSB)
0B3DH	PMON Bit Error/CRCE Count (MSB)
0B3EH	PMON Reserved
0B3FH	PMON Reserved
0B40H- 0B4FH	Reserved
0B50H	PRBS Generator/Checker Control
0B51H	PRBS Checker Interrupt Enable/Status
0B52H	PRBS Pattern Select
0B53H	PRBS Reserved

<b>Address</b>	<b>Register</b>
0B54H	PRBS Error Count Register #1
0B55H	PRBS Error Count Register #2
0B56H	PRBS Error Count Register #3
0B57H	PRBS Reserved
0B58H- 0B6BH	Reserved
0B6CH	T1 FRMR Configuration
0B6DH	T1 FRMR Interrupt Enable
0B6EH	T1 FRMR Interrupt Status
0B6FH	T1 FRMR Reserved
0B70H- 0B7FH	Reserved
<b>0B80H- 0BFFH</b>	<b>T1 PMON #23</b>
<b>0C00H- 0C7FH</b>	<b>T1 PMON #24</b>
<b>0C80H- 0CFFH</b>	<b>T1 PMON #25</b>
<b>0D00H- 0D7FH</b>	<b>T1 PMON #26</b>
<b>0D80H- 0DFFH</b>	<b>T1 PMON #27</b>
<b>0E00H- 0E7FH</b>	<b>T1 PMON #28</b>
0E80H- 0FFFH	Reserved
<b>1000H- 10FFH</b>	<b>DS3 FRAMER and M13 Multiplexer</b>
1000H	DS3 Master Reset
1001H	DS3 Master Data Source
1002H	DS3 Master Unchannelized Interface Options
1003H	DS3 Master Transmit Line Options

<b>Address</b>	<b>Register</b>
1004H	DS3 Master Receive Line Options
1005H	DS3 Master Alarm Enable
1006H	DS2 Master Alarm Enable / Network Requirement Bit
1007H	Reserved
1008H	DS3 TRAN Configuration
1009H	DS3 TRAN Diagnostic
100AH- 100BH	DS3 TRAN Reserved
100CH	DS3 FRMR Configuration
100DH	DS3 FRMR Interrupt Enable/Additional Configuration
100EH	DS3 FRMR Interrupt Status
100FH	DS3 FRMR Status
1010H	DS3 PMON Performance Meters
1011H	DS3 PMON Interrupt Enable/Status
1012H	DS3 PMON Reserved
1013H	DS3 PMON Reserved
1014H	DS3 PMON Line Code Violation Event Count LSB
1015H	DS3 PMON Line Code Violation Event Count MSB
1016H	DS3 PMON Framing Bit Error Event Count LSB
1017H	DS3 PMON Framing Bit Error Event Count MSB
1018H	DS3 PMON Excessive Zeros LSB
1019H	DS3 PMON Excessive Zeros MSB
101AH	DS3 PMON Parity Error Event Count LSB
101BH	DS3 PMON Parity Error Event Count MSB
101CH	DS3 PMON Path Parity Error Event Count LSB
101DH	DS3 PMON Path Parity Error Event Count MSB
101EH	DS3 PMON FEBE Event Count LSB
101FH	DS3 PMON FEBE Event Count MSB
1020H	DS3 TDPR Configuration

<b>Address</b>	<b>Register</b>
1021H	DS3 TDPR Upper Transmit Threshold
1022H	DS3 TDPR Lower Interrupt Threshold
1023H	DS3 TDPR Interrupt Enable
1024H	DS3 TDPR Interrupt Status/UDR Clear
1025H	DS3 TDPR Transmit Data
1026H- 1027H	DS3 TDPR Reserved
1028H	DS3 RDLC Configuration
1029H	DS3 RDLC Interrupt Control
102AH	DS3 RDLC Status
102BH	DS3 RDLC Data
102CH	DS3 RDLC Primary Address Match
102DH	DS3 RDLC Secondary Address Match
102EH- 102FH	DS3 RDLC Reserved
1030H	PRGD Control
1031H	PRGD Interrupt Enable/Status
1032H	PRGD Length
1033H	PRGD Tap
1034H	PRGD Error Insertion
1035H- 1037H	PRGD Reserved
1038H	PRGD Pattern Insertion Register #1
1039H	PRGD Pattern Insertion Register #2
103AH	PRGD Pattern Insertion Register #3
103BH	PRGD Pattern Insertion Register #4
103CH	PRGD Pattern Detector Register #1
103DH	PRGD Pattern Detector Register #2
103EH	PRGD Pattern Detector Register #3

Address	Register
103FH	PRGD Pattern Detector Register #4
1040H	MX23 Configuration
1041H	MX23 Demux AIS Insert
1042H	MX23 Mux AIS Insert
1043H	MX23 Loopback Activate
1044H	MX23 Loopback Request Insert
1045H	MX23 Loopback Request Detect
1046H	MX23 Loopback Request Interrupt
1047H	MX23 Reserved
1048H	FEAC XBOC Control
1049H	FEAC XBOC Code
104AH	FEAC RBOC Configuration/Interrupt Enable
104BH	FEAC RBOC Interrupt Status
104CH- 105FH	Reserved
1060H	DS2 FRMR #1 Configuration
1061H	DS2 FRMR #1 Interrupt Enable
1062H	DS2 FRMR #1 Interrupt Status
1063H	DS2 FRMR #1 Status
1064H	DS2 FRMR #1 Monitor Interrupt Enable/Status
1065H	DS2 FRMR #1 FERR Count
1066H	DS2 FRMR #1 PERR Count (LSB)
1067H	DS2 FRMR #1 PERR Count (MSB)
1066H- 1067H	DS2 FRMR #1 Reserved
1068H- 106FH	Reserved
1070H	MX12 #1 Configuration and Control
1071H	MX12 #1 Loopback Code Select

<b>Address</b>	<b>Register</b>
1072H	MX12 #1 Mux/Demux AIS Insert
1073H	MX12 #1 Loopback Activate
1074H	MX12 #1 Loopback Interrupt
1075H- 1077H	MX12 #1 Reserved
1078H- 107FH	Reserved
1080H- 1087H	DS2 FRMR #2 Registers
1088H- 108FH	Reserved
1090H- 1097H	MX12 #2 Registers
1098H- 109FH	Reserved
10A0H- 10A7H	DS2 FRMR #3 Registers
10A8H- 10AFH	Reserved
10B0H- 10B7H	MX12 #3 Registers
10B8H- 10BFH	Reserved
10C0H- 10C7H	DS2 FRMR #4 Registers
10C8H- 10CFH	Reserved
10D0H- 10D7H	MX12 #4 Registers
10D8H- 10DFH	Reserved
10E0H- 10E7H	DS2 FRMR #5 Registers

Address	Register
10E8H-10EFH	Reserved
10F0H-10F7H	MX12 #5 Registers
10F8H-10FFH	Reserved
1100H-1107H	DS2 FRMR #6 Registers
1108H-110FH	Reserved
1110H-1117H	MX12 #6 Registers
1118H-111FH	Reserved
1120H-1127H	DS2 FRMR #7 Registers
1128H-112FH	Reserved
1130H-1137H	MX12 #7 Registers
1138H-11FFH	Reserved
<b>1200H-16FFH</b>	<b>SONET/SDH Mapper and Demapper</b>
1200H	SONET/SDH Master Configuration
1201H	SONET/SDH Master Ingress Configuration
1202H	SONET/SDH Master Egress Configuration
1203H	SONET/SDH Master Ingress VTPP Configuration
1204H	SONET/SDH Master Egress VTPP Configuration
1205H	SONET/SDH Master RTOP Configuration
1206H	SONET/SDH Master Tributary Alarm AIS Control
1207H	SONET/SDH Master Tributary Remote Defect Indication Control

Address	Register
1208H	SONET/SDH Master Tributary Auxiliary Remote Defect Indication Control
1209H	SONET/SDH Master DS3 Clock Generation Control
120AH	SONET/SDH Master Loopback Control
120BH	SONET/SDH Telecom Bus Signal Monitor, Accumulation Trigger
120CH-121FH	SONET/SDH Reserved
1220H-123FH	Ingress PISO Reserved
1240H	VTPP Ingress, TU #1 in TUG2 #1, Configuration and Status
1241H	VTPP Ingress, TU #1 in TUG2 #1, Alarm Status
1242H	VTPP Ingress, TU #1 in TUG2 #2, Configuration and Status
1243H	VTPP Ingress, TU #1 in TUG2 #2, Alarm Status
1244H	VTPP Ingress, TU #1 in TUG2 #3, Configuration and Status
1245H	VTPP Ingress, TU #1 in TUG2 #3, Alarm Status
1246H	VTPP Ingress, TU #1 in TUG2 #4, Configuration and Status
1247H	VTPP Ingress, TU #1 in TUG2 #4, Alarm Status
1248H	VTPP Ingress, TU #1 in TUG2 #5, Configuration and Status
1249H	VTPP Ingress, TU #1 in TUG2 #5, Alarm Status
124AH	VTPP Ingress, TU #1 in TUG2 #6, Configuration and Status
124BH	VTPP Ingress, TU #1 in TUG2 #6, Alarm Status
124CH	VTPP Ingress, TU #1 in TUG2 #7, Configuration and Status
124DH	VTPP Ingress, TU #1 in TUG2 #7, Alarm Status
124EH	VTPP Ingress, TU #1 in TUG2 #1 to TUG2 #7, LOP Interrupt
124FH	VTPP Ingress, TU #1 in TUG2 #1 to TUG2 #7, AIS Interrupt
1250H-125DH	VTPP Ingress, TU #2 in TUG2 #1 to TUG2 #7, Configuration and Status/Alarm Status
125EH	VTPP Ingress, TU #2 in TUG2 #1 to TUG2 #7, LOP Interrupt

Address	Register
125FH	VTPP Ingress, TU #2 in TUG2 #1 to TUG2 #7 AIS Interrupt
1260H-126DH	VTPP Ingress, TU #3 in TUG2 #1 to TUG2 #7, Configuration and Status/Alarm Status
126EH	VTPP Ingress, TU #3 in TUG2 #1 to TUG2 #7, LOP Interrupt
126FH	VTPP Ingress, TU #3 in TUG2 #1 to TUG2 #7, AIS Interrupt
1270H-127DH	VTPP Ingress, TU #4 in TUG2 #1 to TUG2 #7, Configuration and Status/Alarm Status
127EH	VTPP Ingress, TU #4 in TUG2 #1 to TUG2 #7, LOP Interrupt
127FH	VTPP Ingress, TU #4 in TUG2 #1 to TUG2 #7, AIS Interrupt
1280H	RTDM TU #1 in TUG2 #1 of TUG3 #1, Control
1281H	RTDM TU #1 in TUG2 #2 of TUG3 #1, Control
1282H	RTDM TU #1 in TUG2 #3 of TUG3 #1, Control
1283H	RTDM TU #1 in TUG2 #4 of TUG3 #1, Control
1284H	RTDM TU #1 in TUG2 #5 of TUG3 #1, Control
1285H	RTDM TU #1 in TUG2 #6 of TUG3 #1, Control
1286H	RTDM TU #1 in TUG2 #7 of TUG3 #1, Control
1287H	RTDM Reserved
1288H-128EH	RTDM TU #2 in TUG2 #1 to TUG#7 of TUG3 #1, Control
128FH	RTDM Reserved
1290H-1296H	RTDM TU #3 in TUG2 #1 to TUG#7 of TUG3 #1, Control
1297H	RTDM Reserved
1298H-129EH	RTDM TU #4 in TUG2 #1 to TUG#7 of TUG3 #1, Control
129FH	RTDM Reserved
12A0H-12BEH	RTDM TUs #1-4, in TUG2s #1-7 of TUG3 #2, Control
12BFH	RTDM Reserved

<b>Address</b>	<b>Register</b>
12C0H-12DEH	RTDM TUs #1-4, in TUG2s #1-7 of TUG3 #3, Control
12DFH	RTDM Reserved
12E0H	RTDM Pointer Justification Rate Control
12E1H	RTDM Reserved
12E2H	RTDM Time Switch Page Control
12E3H	RTDM Indirect Time Switch Tributary RAM Status and Control
12E4H	RTDM Indirect Time Switch Tributary Data
12E5H	RTDM Indirect Time Switch Tributary Address
12E6H-12FFH	Reserved
1300H	RTOP TU #1 in TUG2 #1, Configuration
1301H	RTOP TU #1 in TUG2 #1, Configuration and Alarm Status
1302H	RTOP TU #1 in TUG2 #1, Expected Path Signal Label
1303H	RTOP TU #1 in TUG2 #1, Accepted Path Signal Label
1304H	RTOP TU #1 in TUG2 #1, BIP-2 Error Count LSB
1305H	RTOP TU #1 in TUG2 #1, BIP-2 Error Count MSB
1306H	RTOP TU #1 in TUG2 #1, FEBE Error Count LSB
1307H	RTOP TU #1 in TUG2 #1, FEBE Error Count MSB
1308H-130FH	RTOP TU #1 in TUG2 #2, Configuration and Status Registers
1310H-1317H	RTOP TU #1 in TUG2 #3, Configuration and Status Registers
1318H-131FH	RTOP TU #1 in TUG2 #4, Configuration and Status Registers
1320H-1327H	RTOP TU #1 in TUG2 #5, Configuration and Status Registers
1328H-132FH	RTOP TU #1 in TUG2 #6, Configuration and Status Registers

Address	Register
1330H-1337H	RTOP TU #1 in TUG2 #7, Configuration and Status Registers
1338H	RTOP TU #1 in TUG2 #1 to TUG2 #7, COPS� Interrupt
1339H	RTOP TU #1 in TUG2 #1 to TUG2 #7, PSLM Interrupt
133AH	RTOP TU #1 in TUG2 #1 to TUG2 #7, PSLU Interrupt
133BH	RTOP TU #1 in TUG2 #1 to TUG2 #7, RDI Interrupt
133CH	RTOP TU #1 in TUG2 #1 to TUG2 #7, RFI Interrupt
133DH	RTOP TU #1 in TUG2 #1 to TUG2 #7, Inband Error Reporting Configuration
133EH-133FH	RTOP Reserved
1340H-1347H	RTOP TU #2 in TUG2 #1, Configuration and Status Registers
1348H-134FH	RTOP TU #2 in TUG2 #2, Configuration and Status Registers
1350H-1357H	RTOP TU #2 in TUG2 #3, Configuration and Status Registers
1358H-135FH	RTOP TU #2 in TUG2 #4, Configuration and Status Registers
1360H-1367H	RTOP TU #2 in TUG2 #5, Configuration and Status Registers
1368H-136FH	RTOP TU #2 in TUG2 #6, Configuration and Status Registers
1370H-1377H	RTOP TU #2 in TUG2 #7, Configuration and Status Registers
1378H	RTOP TU #2 in TUG2 #1 to TUG2 #7, COPS� Interrupt
1379H	RTOP TU #2 in TUG2 #1 to TUG2 #7, PSLM Interrupt
137AH	RTOP TU #2 in TUG2 #1 to TUG2 #7, PSLU Interrupt
137BH	RTOP TU #2 in TUG2 #1 to TUG2 #7, RDI Interrupt
137CH	RTOP TU #2 in TUG2 #1 to TUG2 #7, RFI Interrupt
137DH	RTOP TU #2 in TUG2 #1 to TUG2 #7, Inband Error Reporting Configuration

<b>Address</b>	<b>Register</b>
137EH-137FH	RTOP Reserved
1380H-1387H	RTOP TU #3 in TUG2 #1, Configuration and Status Registers
1388H-138FH	RTOP TU #3 in TUG2 #2, Configuration and Status Registers
1390H-1397H	RTOP TU #3 in TUG2 #3, Configuration and Status Registers
1398H-139FH	RTOP TU #3 in TUG2 #4, Configuration and Status Registers
13A0H-13A7H	RTOP TU #3 in TUG2 #5, Configuration and Status Registers
13A8H-13AFH	RTOP TU #3 in TUG2 #6, Configuration and Status Registers
13B0H-13B7H	RTOP TU #3 in TUG2 #7, Configuration and Status Registers
13B8H	RTOP TU #3 in TUG2 #1 to TUG2 #7, COPSL Interrupt
13B9H	RTOP TU #3 in TUG2 #1 to TUG2 #7, PSLM Interrupt
13BAH	RTOP TU #3 in TUG2 #1 to TUG2 #7, PSLU Interrupt
13BBH	RTOP TU #3 in TUG2 #1 to TUG2 #7, RDI Interrupt
13BCH	RTOP TU #3 in TUG2 #1 to TUG2 #7, RFI Interrupt
13BDH	RTOP TU #3 in TUG2 #1 to TUG2 #7, Inband Error Reporting Configuration
13BEH-13BFH	RTOP Reserved
13C0H-13C7H	RTOP TU #4 in TUG2 #1, Configuration and Status Registers
13C8H-13CFH	RTOP TU #4 in TUG2 #2, Configuration and Status Registers
13D0H-13D7H	RTOP TU #4 in TUG2 #3, Configuration and Status Registers
13D8H-13DFH	RTOP TU #4 in TUG2 #4, Configuration and Status Registers

<b>Address</b>	<b>Register</b>
13E0H-13E7H	RTOP TU #4 in TUG2 #5, Configuration and Status Registers
13E8H-13EFH	RTOP TU #4 in TUG2 #6, Configuration and Status Registers
13F0H-13F7H	RTOP TU #4 in TUG2 #7, Configuration and Status Registers
13F8H	RTOP TU #4 in TUG2 #1 to TUG2 #7, COPSL Interrupt
13F9H	RTOP TU #4 in TUG2 #1 to TUG2 #7, PSLM Interrupt
13FAH	RTOP TU #4 in TUG2 #1 to TUG2 #7, PSLU Interrupt
13FBH	RTOP TU #4 in TUG2 #1 to TUG2 #7, RDI Interrupt
13FCH	RTOP TU #4 in TUG2 #1 to TUG2 #7, RFI Interrupt
13FDH	RTOP TU #4 in TUG2 #1 to TUG2 #7, InBand Error Reporting Configuration
13FEH-13FFH	RTOP Reserved
1400H	VTPP Egress, TU #1 in TUG2 #1, Configuration and Status
1401H	VTPP Egress, TU #1 in TUG2 #1, Alarm Status
1402H	VTPP Egress, TU #1 in TUG2 #2, Configuration and Status
1403H	VTPP Egress, TU #1 in TUG2 #2, Alarm Status
1404H	VTPP Egress, TU #1 in TUG2 #3, Configuration and Status
1405H	VTPP Egress, TU #1 in TUG2 #3, Alarm Status
1406H	VTPP Egress, TU #1 in TUG2 #4, Configuration and Status
1407H	VTPP Egress, TU #1 in TUG2 #4, Alarm Status
1408H	VTPP Egress, TU #1 in TUG2 #5, Configuration and Status
1409H	VTPP Egress, TU #1 in TUG2 #5, Alarm Status
140AH	VTPP Egress, TU #1 in TUG2 #6, Configuration and Status
140BH	VTPP Egress, TU #1 in TUG2 #6, Alarm Status
140CH	VTPP Egress, TU #1 in TUG2 #7, Configuration and Status
140DH	VTPP Egress, TU #1 in TUG2 #7, Alarm Status

Address	Register
140EH	VTPP Egress, TU #1 in TUG2 #1 to TUG2 #7, LOP Interrupt
140FH	VTPP Egress, TU #1 in TUG2 #1 to TUG2 #7, AIS Interrupt
1410H-141DH	VTPP Egress, TU #2 in TUG2 #1 to TUG2 #7, Configuration and Status/Alarm Status
141EH	VTPP Egress, TU #2 in TUG2 #1 to TUG2 #7, LOP Interrupt
141FH	VTPP Egress, TU #2 in TUG2 #1 to TUG2 #7 AIS Interrupt
1420H-142DH	VTPP Egress, TU #3 in TUG2 #1 to TUG2 #7, Configuration and Status/Alarm Status
142EH	VTPP Egress, TU #3 in TUG2 #1 to TUG2 #7, LOP Interrupt
142FH	VTPP Egress, TU #3 in TUG2 #1 to TUG2 #7, AIS Interrupt
1430H-143DH	VTPP Egress, TU #4 in TUG2 #1 to TUG2 #7, Configuration and Status/Alarm Status
143EH	VTPP Egress, TU #4 in TUG2 #1 to TUG2 #7, LOP Interrupt
143FH	VTPP Egress, TU #4 in TUG2 #1 to TUG2 #7, AIS Interrupt
1440H-147FH	Reserved
1480H	TRAP TU #1 in TUG2 #1 of TU3 #1, Control
1481H	TRAP TU #1 in TUG2 #2 of TU3 #1, Control
1482H	TRAP TU #1 in TUG2 #3 of TU3 #1, Control
1483H	TRAP TU #1 in TUG2 #4 of TU3 #1, Control
1484H	TRAP TU #1 in TUG2 #5 of TU3 #1, Control
1485H	TRAP TU #1 in TUG2 #6 of TU3 #1, Control
1486H	TRAP TU #1 in TUG2 #7 of TU3 #1, Control
1487H	TRAP TU #1 in TUG2 #1 to TUG2 #7 of TUG3 #1, Egress AIS Control
1488H-148EH	TRAP TU #2 in TUG2 #1 to TUG#7 of TU3 #1, Control

Address	Register
148FH	TRAP TU#2 in TUG2 #1 to TUG2 #7 of TU3 #1, Egress AIS Control
1490H-1496H	TRAP TU #3 in TUG2 #1 to TUG#7 of TU3 #1, Control
1497H	TRAP TU#3 in TUG2 #1 to TUG2 #7 of TU3 #1, Egress AIS Control
1498H-149EH	TRAP TU #4 in TUG2 #1 to TUG#7 of TU3 #1, Control
149FH	TRAP TU#4 in TUG2 #1 to TUG2 #7 of TU3 #1, Egress AIS Control
14A0H-14BFH	TRAP TUs #1 to 4 in TUG2s #1 to 7 of TUG3 #2, Control and Egress AIS Control
14C0H-14DFH	TRAP TUs #1 to 4 in TUG2s #1 to 7 of TUG3 #3, Control and Egress AIS Control
14E0H	TRAP Indirect Remote Alarm Page Address
14E 1H	TRAP Indirect Remote Alarm Tributary Address
14E2H	TRAP Indirect Datapath Tributary Data
14E3H	TRAP RDI Control
14E4H-14E7H	TRAP Reserved
14E8H	TRAP Remote Parallel Alarm Port TUG2 #1 of TUG3 #1 Configuration
14E9H-14EEH	TRAP Remote Parallel Alarm Port TUG2 #2 to TUG2 #7 of TUG3 #1 Configuration
14EFH	TRAP Reserved
14F0H-14F6H	TRAP Remote Parallel Alarm Port TUG2 #1 to TUG2 #7 of TUG3 #2 Configuration
14F7H	TRAP Reserved
14F8H-14FEH	TRAP Remote Parallel Alarm Port TUG2 #1 to TUG2 #7 of TUG3 #3 Configuration
14FFH	TRAP Reserved
1500H	TTOP TU #1 in TUG2 #1 of TUG3 #1, Control

Address	Register
1501H	TTOP TU #1 in TUG2 #2 of TUG3 #1, Control
1502H	TTOP TU #1 in TUG2 #3 of TUG3 #1, Control
1503H	TTOP TU #1 in TUG2 #4 of TUG3 #1, Control
1504H	TTOP TU #1 in TUG2 #5 of TUG3 #1, Control
1505H	TTOP TU #1 in TUG2 #6 of TUG3 #1, Control
1506H	TTOP TU #1 in TUG2 #7 of TUG3 #1, Control
1507H	TTOP TU #1 in TUG2 #1 to TUG2 #7 of TUG3 #1 BIP Diagnostic Control
1508H-150EH	TTOP TU #2 in TUG2 #1 to TUG#7 of TUG3 #1, Control
150FH	TTOP TU #2 in TUG2 #1 to TUG2 #7 of TUG3 #1, BIP Diagnostic Control
1510H-1516H	TTOP TU #3 in TUG2 #1 to TUG#7 of TUG3 #1, Control
1517H	TTOP TU #3 in TUG2 #1 to TUG2 #7 of TUG3 #1, BIP Diagnostic Control
1518H-151EH	TTOP TU #4 in TUG2 #1 to TUG#7 of TUG3 #1, Control
151FH	TTOP TU #4 in TUG2 #1 to TUG2 #7 of TUG3 #1, BIP Diagnostic Control
1520H-153FH	TTOP TUs #1 to 4 in TUG2s #1 to 7 of TUG3 #2, Control and BIP Diagnostic Control
1540H-155FH	TTOP TUs #1 to 4 in TUG2s #1 to 7 of TUG3 #3, Control and BIP Diagnostic Control
1560H	TTOP TUG3 #1 Control
1561H	TTOP TUG3 #2 Control
1562H	TTOP TUG3 #3 Control
1563H	Reserved
1564H	TTOP Trail Trace Identifier Page Select
1565H	TTOP Indirect Trail Trace Identifier Tributary Select
1566H	TTOP Indirect Trail Trace Identifier Buffer Address

<b>Address</b>	<b>Register</b>
1567H	TTOP Indirect Trail Trace Identifier Buffer Data
1568H-157FH	Reserved
1580H	TTMP TU #1 in TUG2 #1 of TUG3 #1, Tributary Control
1581H	TTMP TU #1 in TUG2 #2 of TUG3 #1, Tributary Control
1582H	TTMP TU #1 in TUG2 #3 of TUG3 #1, Tributary Control
1583H	TTMP TU #1 in TUG2 #4 of TUG3 #1, Tributary Control
1584H	TTMP TU #1 in TUG2 #5 of TUG3 #1, Tributary Control
1585H	TTMP TU #1 in TUG2 #6 of TUG3 #1, Tributary Control
1586H	TTMP TU #1 in TUG2 #7 of TUG3 #1, Tributary Control
1587H	Reserved
1588H-158EH	TTMP TU #2 in TUG2 #1 to TUG#7 of TUG3 #1, Tributary Control
158FH	Reserved
1590H-1596H	TTMP TU #3 in TUG2 #1 to TUG#7 of TUG3 #1, Tributary Control
1597H	Reserved
1598H-159EH	TTMP TU #4 in TUG2 #1 to TUG#7 of TUG3 #1, Tributary Control
159FH	Reserved
15A0H-15BFH	TTMP TUs #1 to 4 in TUG2s #1 to 7 of TUG3 #2, Tributary Control
15C0H-15DFH	TTMP TUs #1 to 4 in TUG2s #1 to 7 of TUG3 #3, Tributary Control
15E0H	TTMP Reserved
15E1H	TTMP Time Switch Page Control
15E2H	TTMP Indirect Time Switch RAM Control and Status
15E3H	TTMP Indirect Time Switch Tributary Address
15E4H	TTMP Indirect Time Switch Tributary Data
15E5H	TTMP Telecom Interface Configuration

<b>Address</b>	<b>Register</b>
15E6H-15FFH	Reserved
1600H-163FH	Egress SIPO Reserved
1640H	D3MD Control
1641H	D3MD Interrupt Status
1642H	D3MD Interrupt Enable
1643H	Reserved
1644H	D3MA Control
1645H	D3MA Interrupt Status
1646H	D3MA Interrupt Enable
1647H	Reserved
1648H-16FFH	Reserved
<b>1700H-179FH</b>	<b>SBI Interface</b>
1700H	SBI Master Reset / Bus Signal Monitor
1701H	SBI Master Configuration
1702H	SBI Bus Master Configuration
1703H-170FH	SBI Reserved
1710H	EXSBI Control
1711H	EXSBI FIFO Underrun Interrupt Status
1712H	EXSBI FIFO Overrun Interrupt Status
1713H	EXSBI Tributary RAM Indirect Access Address
1714H	EXSBI Tributary RAM Indirect Access Control
1715H	EXSBI Reserved
1716H	EXSBI Tributary Control Indirect Access Data
1717H	EXSBI SBI Parity Error Interrupt Status
161AH	EXSBI Reserved

Address	Register
161BH	EXSBI Reserved
1718H- 171DH	EXSBI Reserved
171EH	EXSBI Depth Check Interrupt Status
171FH	EXSBI Extract External ReSynch Interrupt Status
1720H	INSBI Control
1721H	INSBI FIFO Underrun Interrupt Status
1722H	INSBI FIFO Overrun Interrupt Status
1723H	INSBI Tributary Register Indirect Access Address
1724H	INSBI Tributary Register Indirect Access Control
1725H	INSBI Reserved
1726H	INSBI Tributary Control Indirect Access Data
1609H- 160EH	INSBI Reserved
1727H- 172FH	INSBI Reserved
1731H	INSBI Depth Check Interrupt Status
1732H	INSBI Insert External ReSynch Interrupt Status
1733H- 173FH	INSBI Reserved
1740H- 175FH	SBI SIPO Reserved
1760H- 177FH	SBI PISO Reserved
1780H- 1FFFH	Reserved

For all register accesses, CSB must be low.

## **10 NORMAL MODE REGISTER DESCRIPTION**

Normal mode registers are used to configure and monitor the operation of the TEMAP. Normal mode registers (as opposed to test mode registers) are selected when TRS (A[13]) is low.

Notes on Normal Mode Register Bits:

- 1) Writing values into unused register bits typically has no effect. However, to ensure software compatibility with future, feature-enhanced versions of the product, unused register bit must be written with logic 0. Reading back unused bits can produce either a logic 1 or a logic 0; hence unused register bits should be masked off by software when read.
- 2) All configuration bits that can be written into can also be read back. This allows the processor controlling the TEMAP to determine the programming state of the block.
- 3) Writeable normal mode register bits are cleared to logic 0 upon reset unless otherwise noted.
- 4) Writing into read-only normal mode register bit locations does not affect TEMAP operation unless otherwise noted.

The register descriptions are contained in a separate TEMAP register description document.

## **11 TEST FEATURES DESCRIPTION**

The TEMAP contains test features for both production testing and board testing.

Simultaneously asserting the CSB, RDB and WRB inputs causes all output pins and the data bus to be held in a high-impedance state. This test feature may be used for board testing.

Test mode registers are used to apply test vectors during production testing of the TEMAP. Test mode registers (as opposed to normal mode registers) are selected when TRS (A[13]) is high.

Test mode registers may also be used for board testing. When all of the constituent Telecom System Blocks within the TEMAP are placed in test mode 0, device inputs may be read and device outputs may be forced via the microprocessor interface (refer to the section "Test Mode 0" for details).

### **Test Mode Register Memory Map**

Address	Register
---------	----------

Notes on Register Bits:

- 1) Writing values into unused register bits has no effect. Reading back unused bits can produce either a logic one or a logic zero; hence unused bits should be masked off by software when read.
- 2) Writeable register bits are not initialized upon reset unless otherwise noted.

### Register 0000H: Master Test Register

Bit	Type	Function	Default
Bit 7		Unused	X
Bit 6		Unused	X
Bit 5		Unused	X
Bit 4	W	PMCTST	X
Bit 3	W	DBCTRL	X
Bit 2	R/W	IOTST	X
Bit 1	W	HIZDATA	X
Bit 0	R/W	HIZIO	X

This register is used to select TEMAP test features. All bits, except for PMCTST, are reset to zero by a hardware reset of the TEMAP; a software reset of the TEMAP does not affect the state of the bits in this register.

#### PMCTST:

The PMCTST bit is used to configure the TEMAP for PMC's manufacturing tests. When PMCTST is set to logic 1, the TEMAP microprocessor port becomes the test access port used to run the PMC "canned" manufacturing test vectors. The PMCTST bit is logically "ORed" with the IOTST bit, and can only be cleared by setting CSB to logic 1.

#### DBCTRL:

The DBCTRL bit is used to pass control of the data bus drivers to the CSB pin while IOTST is a logic 1. When the DBCTRL bit is set to logic 1, the CSB pin controls the output enable for the data bus. While the DBCTRL bit is set, holding the CSB pin high causes the TEMAP to drive the data bus and holding the CSB pin low tri-states the data bus. The DBCTRL bit overrides the HIZDATA bit. The DBCTRL bit is used to measure the drive capability of the data bus driver pads. When IOTST and PMCTST are both logic 0, the DBCTRL bit is ignored.

#### IOTST:

The IOTST bit is used to allow normal microprocessor access to the test registers and control the test mode in each TSB block in the TEMAP for board level testing. When IOTST is a logic 1, all blocks are held in test mode and the microprocessor may write to a block's test mode 0 registers to

manipulate the outputs of the block and consequently the device outputs (refer to the "Test Mode 0 Details" in the "Test Features" section).

#### HIZIO:

The HIZIO bit controls the tri-state modes of the output pins of the TEMAP. While the HIZIO bit is a logic 1, all output pins of the TEMAP, except the data bus, are held in a high-impedance state. The microprocessor interface is still active.

#### HIZDATA:

The HIZDATA bit controls the tri-state modes of the TEMAP. While the HIZIO bit is a logic 1, all output pins of the TEMAP, except the data bus, are held in a high-impedance state. While the HIZDATA bit is a logic 1, the data bus is also held in a high-impedance state which inhibits microprocessor read cycles.

### **11.1 JTAG Test Port**

The TEMAP JTAG Test Access Port (TAP) allows access to the TAP controller and the 4 TAP registers: instruction, bypass, device identification and boundary scan. Using the TAP, device input logic levels can be read, device outputs can be forced, the device can be identified and the device scan path can be bypassed. For more details on the JTAG port, please refer to the Operations section.

**Table 11 - Instruction Register**

Length - 3 bits

Instructions	Selected Register	Instruction Code IR[2:0]
EXTEST	Boundary Scan	000
IDCODE	Identification	001
SAMPLE	Boundary Scan	010
BYPASS	Bypass	011
BYPASS	Bypass	100
STCTEST	Boundary Scan	101
BYPASS	Bypass	110
BYPASS	Bypass	111

**Table 12 - Identification Register**

Length	32 bits
Version number	1H
Part Number	5365H
Manufacturer's identification code	0CDH
Device identification	53650CDH

**11.1.1 Boundary Scan Register**

The boundary scan register is made up of 286 boundary scan cells, divided into input observation (IN\_CELL), output (OUT\_CELL) and bidirectional (IO\_CELL) cells. These cells are detailed in the following pages. The first 32 cells form the ID code register and carry the code 053650CDH. The cells are arranged as follows:

**Table 13 - Boundary Scan Chain**

Pin/Enable	Register Bit	Cell Type	Device I.D.
HIZ	0	OUT_CELL	-
ICLK[28]	1	OUT_CELL	-
ICLK[27]	2	OUT_CELL	-
ICLK[20]	3	OUT_CELL	-
ICLK[19]	4	OUT_CELL	-
UNCONNECTED	5	OUT_CELL	-
ECLK[28]_OEN	6	OUT_CELL	-
ECLK[28]	7	IO_CELL	-
ECLK[27]_OEN	8	OUT_CELL	-
ECLK[27]	9	IO_CELL	-
ECLK[20]_OEN	10	OUT_CELL	-
ECLK[20]	11	IO_CELL	-
ECLK[19]_OEN	12	OUT_CELL	-
ECLK[19]	13	IO_CELL	-
ECLK[12]_OEN	14	OUT_CELL	-
ECLK[12]	15	IO_CELL	-

Pin/Enable	Register Bit	Cell Type	Device I.D.
ECLK[11]_OEN	16	OUT_CELL	-
ECLK[11]	17	IO_CELL	-
UNCONNECTED	18	OUT_CELL	-
UNCONNECTED	19	OUT_CELL	-
ICLK[12]	20	OUT_CELL	-
ICLK[11]	21	OUT_CELL	-
ID[12]	22	OUT_CELL	-
ID[11]	23	OUT_CELL	-
ID[26]	24	OUT_CELL	-
ID[25]	25	OUT_CELL	-
ICLK[26]	26	OUT_CELL	-
ICLK[25]	27	OUT_CELL	-
UNCONNECTED	28	OUT_CELL	-
UNCONNECTED	29	OUT_CELL	-
ECLK[26]_OEN	30	OUT_CELL	-
ECLK[26]	31	IO_CELL	-
ECLK[25]_OEN	32	OUT_CELL	-
ECLK[25]	33	IO_CELL	-
ED[26]	34	IN_CELL	-
ED[25]	35	IN_CELL	-
ED[18]	36	IN_CELL	-
CTCLK	37	IN_CELL	-
LOGIC 0	38	IN_CELL	-
LOGIC 0	39	IN_CELL	-
LOGIC 0	40	IN_CELL	-
LOGIC 0	41	IN_CELL	-
LOGIC 0	42	IN_CELL	-
ED[17]	43	IN_CELL	-
CLK52M	44	IN_CELL	-

Pin/Enable	Register Bit	Cell Type	Device I.D.
ED[10]	45	IN_CELL	-
UNCONNECTED	46	OUT_CELL	-
ECLK[18]_OEN	47	OUT_CELL	-
ECLK[18]	48	IO_CELL	-
ECLK[17]_OEN	49	OUT_CELL	-
ECLK[17]	50	IO_CELL	-
ECLK[10]_OEN	51	OUT_CELL	-
ECLK[10]	52	IO_CELL	-
ED[9]	53	IN_CELL	-
ICLK[18]	54	OUT_CELL	-
ICLK[17]	55	OUT_CELL	-
ID[18]	56	OUT_CELL	-
ID[17]	57	OUT_CELL	-
UNCONNECTED	58	OUT_CELL	-
UNCONNECTED	59	OUT_CELL	-
UNCONNECTED	60	OUT_CELL	-
UNCONNECTED	61	OUT_CELL	-
UNCONNECTED	62	OUT_CELL	-
ID[10]	63	OUT_CELL	-
ID[9]	64	OUT_CELL	-
ICLK[10]	65	OUT_CELL	-
ICLK[9]	66	OUT_CELL	-
ECLK[9]_OEN	67	OUT_CELL	-
ECLK[9]	68	IO_CELL	-
ECLK[2]_OEN	69	OUT_CELL	-
ECLK[2]	70	IO_CELL	-
ICLK[2]	71	OUT_CELL	-
ED[2]_TFPI_TMFPI	72	IN_CELL	-
ECLK[1]_TGAPCLK_OEN	73	OUT_CELL	-

Pin/Enable	Register Bit	Cell Type	Device I.D.
ECLK[1]_TGAPCLK	74	IO_CELL	-
ED[1]_TDATI	75	IN_CELL	-
ID[1]_RDATO	76	OUT_CELL	-
ID[2]_ROVRHD	77	OUT_CELL	-
ICLK[1]_RSCLK	78	OUT_CELL	-
RFPO_RMFPO	79	OUT_CELL	-
TICLK	80	IN_CELL	-
RCLK	81	IN_CELL	-
RPOS_RDAT	82	IN_CELL	-
RNEG_RLCV	83	IN_CELL	-
TCLK	84	OUT_CELL	-
TPOS_TDAT	85	OUT_CELL	-
TNEG_TMFP	86	OUT_CELL	-
LADATA[0]_OEN	87	OUT_CELL	-
LADATA[0]	88	OUT_CELL	-
LADATA[1]_OEN	89	OUT_CELL	-
LADATA[1]	90	OUT_CELL	-
LADATA[2]_OEN	91	OUT_CELL	-
LADATA[2]	92	OUT_CELL	-
LADATA[3]_OEN	93	OUT_CELL	-
LADATA[3]	94	OUT_CELL	-
LADATA[4]_OEN	95	OUT_CELL	-
LADATA[4]	96	OUT_CELL	-
LADATA[5]_OEN	97	OUT_CELL	-
LADATA[5]	98	OUT_CELL	-
LADATA[6]_OEN	99	OUT_CELL	-
LADATA[6]	100	OUT_CELL	-
LADATA[7]_OEN	101	OUT_CELL	-
LADATA[7]	102	OUT_CELL	-

Pin/Enable	Register Bit	Cell Type	Device I.D.
LADP_OEN	103	OUT_CELL	-
LADP	104	OUT_CELL	-
LAPL_OEN	105	OUT_CELL	-
LAPL	106	OUT_CELL	-
LAC1J1V1	107	OUT_CELL	-
LAOE	108	OUT_CELL	-
LREFCLK	109	IN_CELL	-
LDAIS	110	IN_CELL	-
LAC1	111	IN_CELL	-
LDTPL	112	IN_CELL	-
LDDATA[0]	113	IN_CELL	-
LDDATA[1]	114	IN_CELL	-
LDDATA[2]	115	IN_CELL	-
LDDATA[3]	116	IN_CELL	-
LDDATA[4]	117	IN_CELL	-
LDDATA[5]	118	IN_CELL	-
LDDATA[6]	119	IN_CELL	-
LDDATA[7]	120	IN_CELL	-
LDDP	121	IN_CELL	-
LDPL	122	IN_CELL	-
LDV5	123	IN_CELL	-
LDC1J1V1	124	IN_CELL	-
RADEAST	125	IN_CELL	-
RADEASTCLK	126	IN_CELL	-
RADEASTFP	127	IN_CELL	-
RADWEST	128	IN_CELL	-
RADWESTCLK	129	IN_CELL	-
RADWESTFP	130	IN_CELL	-
ICLK[3]	131	OUT_CELL	-

Pin/Enable	Register Bit	Cell Type	Device I.D.
ICLK[4]	132	OUT_CELL	-
ID[3]	133	OUT_CELL	-
ECLK[3]_OEN	134	OUT_CELL	-
ECLK[3]	135	IO_CELL	-
ECLK[4]_OEN	136	OUT_CELL	-
ECLK[4]	137	IO_CELL	-
ECLK[5]_OEN	138	OUT_CELL	-
ECLK[5]	139	IO_CELL	-
UNCONNECTED	140	OUT_CELL	-
UNCONNECTED	141	OUT_CELL	-
UNCONNECTED	142	OUT_CELL	-
UNCONNECTED	143	OUT_CELL	-
UNCONNECTED	144	OUT_CELL	-
UNCONNECTED	145	OUT_CELL	-
ICLK[5]	146	OUT_CELL	-
ICLK[6]	147	OUT_CELL	-
ECLK[6]_OEN	148	OUT_CELL	-
ECLK[6]	149	IO_CELL	-
ECLK[13]_OEN	150	OUT_CELL	-
ECLK[13]	151	IO_CELL	-
ECLK[14]_OEN	152	OUT_CELL	-
ECLK[14]	153	IO_CELL	-
ECLK[21]_OEN	154	OUT_CELL	-
ECLK[21]	155	IO_CELL	-
ECLK[22]_OEN	156	OUT_CELL	-
ECLK[22]	157	IO_CELL	-
ECLK[7]_OEN	158	OUT_CELL	-
ECLK[7]	159	IO_CELL	-
ECLK[8]_OEN	160	OUT_CELL	-

Pin/Enable	Register Bit	Cell Type	Device I.D.
ECLK[8]	161	IO_CELL	-
UNCONNECTED	162	OUT_CELL	-
UNCONNECTED	163	OUT_CELL	-
ID[4]	164	OUT_CELL	-
ID[5]	165	OUT_CELL	-
ID[6]	166	OUT_CELL	-
ID[13]	167	OUT_CELL	-
ID[14]	168	OUT_CELL	-
ED[3]	169	IN_CELL	-
ED[4]	170	IN_CELL	-
ED[5]	171	IN_CELL	-
ED[6]	172	IN_CELL	-
ED[13]	173	IN_CELL	-
ED[14]	174	IN_CELL	-
ID[21]	175	OUT_CELL	-
ID[22]	176	OUT_CELL	-
ICLK[13]	177	OUT_CELL	-
ICLK[14]	178	OUT_CELL	-
UNCONNECTED	179	OUT_CELL	-
UNCONNECTED	180	OUT_CELL	-
UNCONNECTED	181	OUT_CELL	-
UNCONNECTED	182	OUT_CELL	-
UNCONNECTED	183	OUT_CELL	-
UNCONNECTED	184	OUT_CELL	-
ICLK[21]	185	OUT_CELL	-
ICLK[22]	186	OUT_CELL	-
ICLK[7]	187	OUT_CELL	-
ICLK[8]	188	OUT_CELL	-
ID[7]	189	OUT_CELL	-

Pin/Enable	Register Bit	Cell Type	Device I.D.
ID[8]	190	OUT_CELL	-
ICLK[15]	191	OUT_CELL	-
ICLK[16]	192	OUT_CELL	-
ICLK[23]	193	OUT_CELL	-
ICLK[24]	194	OUT_CELL	-
ED[22]	195	IN_CELL	-
ED[21]	196	IN_CELL	-
RECVCLK1	197	OUT_CELL	-
RECVCLK2	198	OUT_CELL	-
XCLK	199	IN_CELL	-
ECLK[15]_OEN	200	OUT_CELL	-
ECLK[15]	201	IO_CELL	-
ECLK[16]_OEN	202	OUT_CELL	-
ECLK[16]	203	IO_CELL	-
ECLK[23]_OEN	204	OUT_CELL	-
ECLK[23]	205	IO_CELL	-
ECLK[24]_OEN	206	OUT_CELL	-
ECLK[24]	207	IO_CELL	-
RSTB	208	IN_CELL	-
A[13]	209	IN_CELL	-
A[12]	210	IN_CELL	-
A[11]	211	IN_CELL	-
A[10]	212	IN_CELL	-
A[9]	213	IN_CELL	-
A[8]	214	IN_CELL	-
A[7]	215	IN_CELL	-
A[6]	216	IN_CELL	-
A[5]	217	IN_CELL	-
A[4]	218	IN_CELL	-

Pin/Enable	Register Bit	Cell Type	Device I.D.
A[3]	219	IN_CELL	-
A[2]	220	IN_CELL	-
A[1]	221	IN_CELL	-
A[0]	222	IN_CELL	-
RDB	223	IN_CELL	-
WRB	224	IN_CELL	-
ALE	225	IN_CELL	-
INTB	226	OUT_CELL	-
CSB	227	IN_CELL	-
D[0]_OEN	228	OUT_CELL	-
D[0]	229	IO_CELL	-
D[1]_OEN	230	OUT_CELL	-
D[1]	231	IO_CELL	-
D[2]_OEN	232	OUT_CELL	-
D[2]	233	IO_CELL	-
D[3]_OEN	234	OUT_CELL	-
D[3]	235	IO_CELL	-
D[4]_OEN	236	OUT_CELL	-
D[4]	237	IO_CELL	-
D[5]_OEN	238	OUT_CELL	-
D[5]	239	IO_CELL	-
D[6]_OEN	240	OUT_CELL	-
D[6]	241	IO_CELL	-
D[7]_OEN	242	OUT_CELL	-
D[7]	243	IO_CELL	-
ID[15]_SDDATA[0]_OEN	244	OUT_CELL	-
ID[15]_SDDATA[0]	245	OUT_CELL	-
ID[16]_SDDATA[1]_OEN	246	OUT_CELL	-
ID[16]_SDDATA[1]	247	OUT_CELL	-

Pin/Enable	Register Bit	Cell Type	Device I.D.
ID[19]_SDDATA[2]_OEN	248	OUT_CELL	-
ID[19]_SDDATA[2]	249	OUT_CELL	-
ID[20]_SDDATA[3]_OEN	250	OUT_CELL	-
ID[20]_SDDATA[3]	251	OUT_CELL	-
ID[23]_SDDATA[4]_OEN	252	OUT_CELL	-
ID[23]_SDDATA[4]	253	OUT_CELL	-
ID[24]_SDDATA[5]_OEN	254	OUT_CELL	1
ID[24]_SDDATA[5]	255	OUT_CELL	0
ID[27]_SDDATA[6]_OEN	256	OUT_CELL	1
ID[27]_SDDATA[6]	257	OUT_CELL	1
ID[28]_SDDATA[7]_OEN	258	OUT_CELL	0
ID[28]_SDDATA[7]	259	OUT_CELL	0
SDDP_OEN	260	OUT_CELL	1
SDDP	261	OUT_CELL	1
SDV5_OEN	262	OUT_CELL	0
SDV5	263	OUT_CELL	0
SDPL_OEN	264	OUT_CELL	0
SDPL	265	OUT_CELL	0
SAJUST_REQ_OEN	266	OUT_CELL	1
SAJUST_REQ	267	OUT_CELL	0
SBIACT_OEB	268	OUT_CELL	1
SBIACT	269	OUT_CELL	0
SBIDET[0]	270	IN_CELL	0
ED[7]_SBIDET[1]	271	IN_CELL	1
SREFCLK	272	IN_CELL	1
SC1FP_OEN	273	OUT_CELL	0
SC1FP	274	IO_CELL	1
ED[15]_SADATA[0]	275	IN_CELL	1
ED[16]_SADATA[1]	276	IN_CELL	0

Pin/Enable	Register Bit	Cell Type	Device I.D.
ED[19]_SADATA[2]	277	IN_CELL	0
ED[20]_SADATA[3]	278	IN_CELL	1
ED[23]_SADATA[4]	279	IN_CELL	0
ED[24]_SADATA[5]	280	IN_CELL	1
ED[27]_SADATA[6]	281	IN_CELL	0
ED[28]_SADATA[7]	282	IN_CELL	1
ED[8]_SADP	283	IN_CELL	0
ED[12]_SAPL	284	IN_CELL	0
ED[11]_SAV5	285	IN_CELL	0
TDO		TAP Output	-
TDI		TAP Input	-
TCK		TAP Clock	-
TMS		TAP Input	-
TRSTB		TAP Input	-

**Notes:**

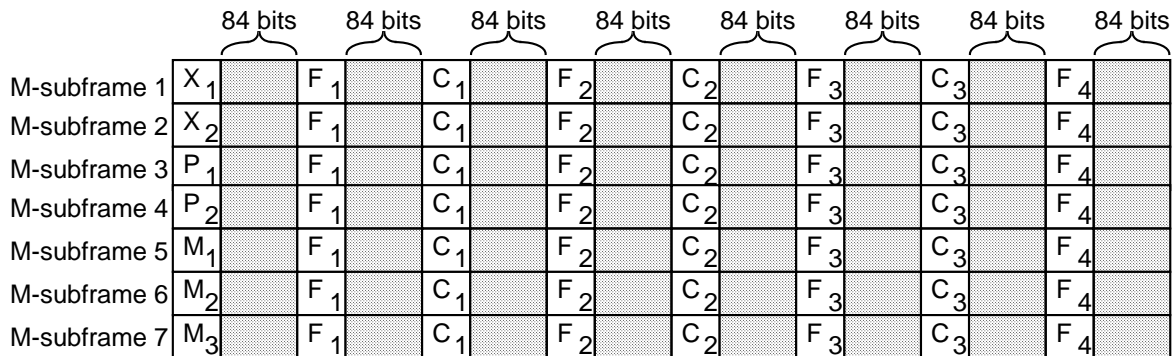
1. Register bit 285 is the first bit of the scan chain (closest to TDI).
2. Enable cell pinname\_OEN, tristates pin pinname when set high.
3. Enable cell HIZ, tristates all pins that do not have an individual pinname\_OEN enable signal.
4. Unconnected register bits in the scan chain are not connected to any pins.
5. Register bits identified as LOGIC 0 will always return a logic 0.

## 12 OPERATION

### 12.1 DS3 Frame Format

The TEMAP provides support for both the C-bit parity and M23 DS3 framing formats. The DS3 frame format is shown in Figure 17.

**Figure 17: DS3 Frame Structure**



#### **X<sub>x</sub>: X-Bit Channel**

- **Transmit:** The TEMAP inserts the FERF signal on the X-bits. FERF generation is controlled by either the FERF bit of the DS3 TRAN Configuration register or by detection of OOF, RED, LOS and AIS, as configured by the TEMAP Master DS3 Alarm Enable register.
- **Receive:** The TEMAP monitors the state and detects changes in the state of the FERF signal on the X-bits.

#### **P<sub>x</sub>: P-Bit Channel**

- **Transmit:** The TEMAP calculates the parity for the payload data over the previous M-frame and inserts it into the P1 and P2 bit positions.
- **Receive:** The TEMAP calculates the parity for the received payload. Errors are accumulated in the DS3 PMON Parity Error Event Count registers.

#### **M<sub>x</sub>: M-Frame Alignment Signal**

- **Transmit:** The TEMAP generates the M-frame alignment signal (M1 = 0, M2 = 1, M3 = 0).
- **Receive:** The TEMAP finds M-frame alignment by searching for the F-bits and the M-bits. Out-of-frame is removed if the M-bits are correct for three consecutive M-frames while no discrepancies have occurred in the F-bits. M-bit errors are counted in the DS3 PMON Framing Bit Error Event Count registers. When one or more M-bit errors are detected in 3 out of 4

consecutive M-frames, an out-of-frame defect is asserted (if MBDIS in the DS3 Framing Configuration register is a logic 0).

### **F<sub>x</sub>: M-Subframe Alignment Signal**

- **Transmit:** The TEMAP generates the M-Subframe Alignment signal (F1=1, F2=0, F3=0, F4=1).
- **Receive:** The TEMAP finds M-frame alignment by searching for the F-bits and the M-bits. Out-of-frame is removed if the M-bits are correct for three consecutive M-frames while no discrepancies have occurred in the F-bits. F-bit errors are counted in the DS3 PMON Framing Bit Error Event Count registers. An out-of frame defect is asserted if 3 F-bit errors out of 8 or 16 consecutive F-bits are observed (as selected by the M3O8 bit in the DS3 FRMR Configuration register).

### **C<sub>x</sub>: C-Bit Channels**

- **Transmit:** When configured for M23 applications, the C-bits are forced to logic 1 with the exception of the C-bit Parity ID bit (the first C-bit of the first M-subframe), which is forced to toggle every M-frame. When configured for C-bit parity applications, the C-bit Parity ID bit is forced to logic 1. The second C-bit in M-subframe 1 is set to logic 1. The third C-bit in M-subframe 1 provides a far-end alarm and control (FEAC) signal. The FEAC channel is sourced by the DS3 XBOC block. The 3 C-bits in M-subframe 3 carry path parity information. The value of these 3 C-bits is the same as that of the P-bits. The 3 C-bits in M-subframe 4 are the FEBE bits. FEBE transmission is controlled by the DFEBE bit in the DS3 TRAN Diagnostic register and by the detection of receive framing bit and path parity errors. The 3 C-bits in M-subframe 5 contain the 28.2 kbit/s path maintenance datalink. These bits are inserted from the DS3 TDPR HDLC controller. The C-bits in M-subframes 2, 6, and 7 are unused and are set to logic 1.
- **Receive:** The CBITV register bit in the DS3 FRMR Status register is used to report the state of the C-bit parity ID bit, and hence whether a M23 or C-bit parity DS3 signal stream is being received. The FEAC channel on the third C-bit in M-subframe 1 is detected by the DS3 RBOC block. Path parity errors and detected FEBEs on the C-bits in M-subframes 3 and 4 are reported in the DS3 PMON Path Parity Error Event Count and FEBE Event Count registers respectively. The path maintenance datalink signal is extracted by the DS3 RDLC HDLC receiver (if enabled).

## **12.2 Servicing Interrupts**

The TEMAP will assert INTB to logic 0 when a condition which is configured to produce an interrupt occurs. To find which condition caused this interrupt to occur, the procedure outlined below should be followed:

1. Read the bits of the TEMAP Master Interrupt Source register (0020H) to identify which of the eight interrupt registers (0021H-0028H) needs to be read to identify the interrupt. For example, a logic one read in the DS3INT register bit indicates that an interrupt identified in the Master Interrupt Source DS3 register produced the interrupt.
2. Read the bits of the second level Master Interrupt Source register to identify the interrupt source.
3. Service the interrupt.
4. If the INTB pin is still logic 0, then there are still interrupts to be serviced. Otherwise, all interrupts have been serviced. Wait for the next assertion of INTB

## **12.3 Using the Performance Monitoring Features**

The PMON blocks are provided for performance monitoring purposes. The DS3 PMON block is used to monitor DS3 performance primitives. The PMON blocks within each T1/E1 Framing slice are used to monitor T1 or E1 performance primitives. The counters in the DS3 PMON block has been sized as not to saturate if polled every second. The T1/E1 PMON event counters are of sufficient length so that the probability of counter saturation over a one second interval is very small (less than 0.001%).

An accumulation interval is initiated by writing to one of the PMON event counter register addresses or by writing to the Master Revision/Global PMON Update register. After initiating an accumulation interval, 3.5 recovered clock periods (RCLK for the DS3 PMON) must be allowed to elapse to permit the PMON counter values to be properly transferred before the PMON registers may be read.

The odds of any one of the T1/E1 counters saturating during a one second sampling interval go up as the bit error rate (BER) increases. At some point, the probability of counter saturation reaches 50%. This point varies, depending upon the framing format and the type of event being counted. The BER at which the probability of counter saturation reaches 50% is shown for various counters in Table 14 for E1 mode, and in Table 15 for T1 mode.

**Table 14 - PMON Counter Saturation Limits (E1 mode)**

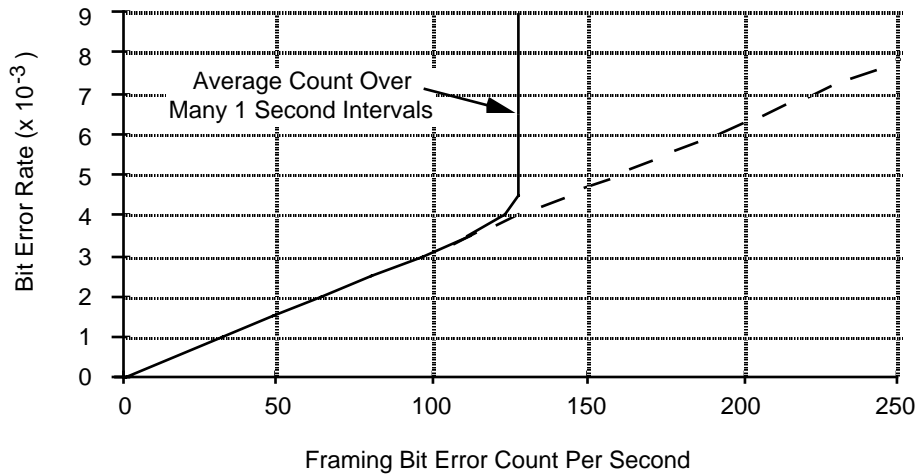
Counter	BER
FER	$4.0 \times 10^{-3}$
CRCE	cannot saturate
FEBE	cannot saturate

**Table 15 - PMON Counter Saturation Limits (T1 mode)**

Counter	Format	BER
FER	SF	$1.6 \times 10^{-3}$
	ESF	$6.4 \times 10^{-2}$
CRCE	SF	$1.28 \times 10^{-1}$
	ESF	cannot saturate

Below these 50% points, the relationship between the BER and the counter event count (averaged over many one second samples) is essentially linear. Above the 50% point, the relationship between BER and the average counter event count is highly non-linear due to the likelihood of counter saturation. The following figures show this relationship for various counters and framing formats. These graphs can be used to determine the BER, given the average event count. In general, if the BER is above  $10^{-3}$ , the average counter event count cannot be used to determine the BER without considering the statistical effect of occasional counter saturation.

Figure 18 illustrates the expected count values for a range of Bit Error Ratios in E1 mode.

**Figure 18 - FER Count vs. BER (E1 mode)**


Since the maximum number of CRC sub-multiframes that can occur in one second is 1000, the 10-bit FEBE and CRCE counters cannot saturate in one second. Despite this, there is not a linear relationship between BER and CRC-4 block errors due to the nature of the CRC-4 calculation. At BERs below  $10^{-4}$ , there tends to be no more than one bit error per sub-multiframe, so the number of CRC-4 errors is generally equal to the number of bit errors, which is directly related to the BER. However, at BERs above  $10^{-4}$ , each CRC-4 error is often due to more than one bit error. Thus, the relationship between BER and CRCE count becomes non-linear above a  $10^{-4}$  BER. This must be taken into account when using CRC-4 counts to determine the BER. Since FEBEs are indications of CRCEs at the far end, and are accumulated identically to CRCEs, the same explanation holds for the FEBE event counter.

The bit error rate for E1 can be calculated from the one-second PMON CRCE count by the following equation:

$$\text{Bit Error Rate} = 1 - 10^{\left( \frac{\log\left(1 - \frac{8}{8000} \text{CRCE}\right)}{8 \cdot 256} \right)}$$

**Figure 19 - CRCE Count vs. BER (E1 mode)**

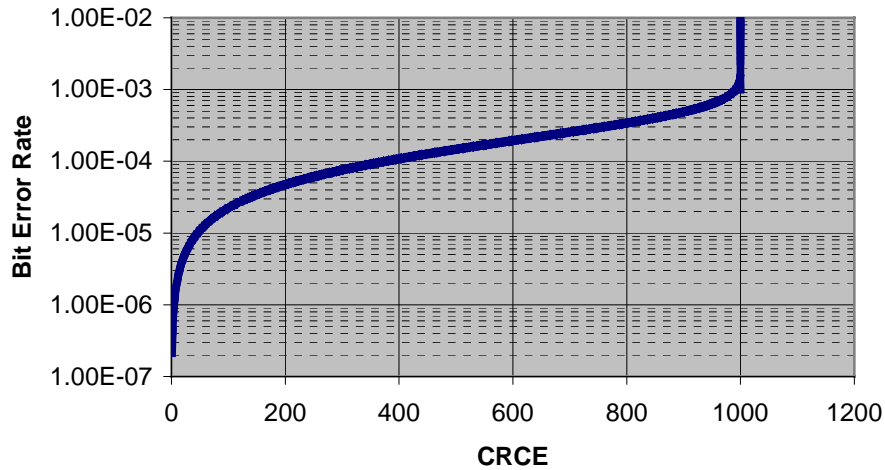
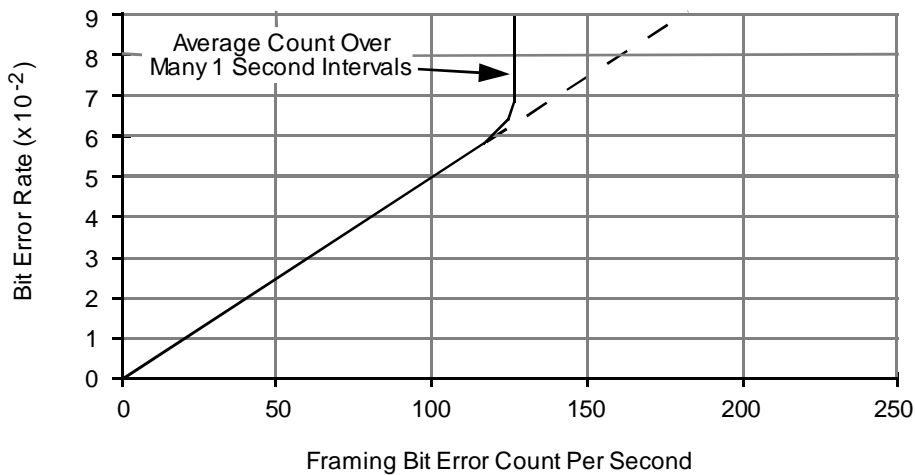


Figure 20 illustrates the expected count values for a range of Bit Error Ratios in T1 mode.

**Figure 20 - FER Count vs. BER (T1 ESF mode)**



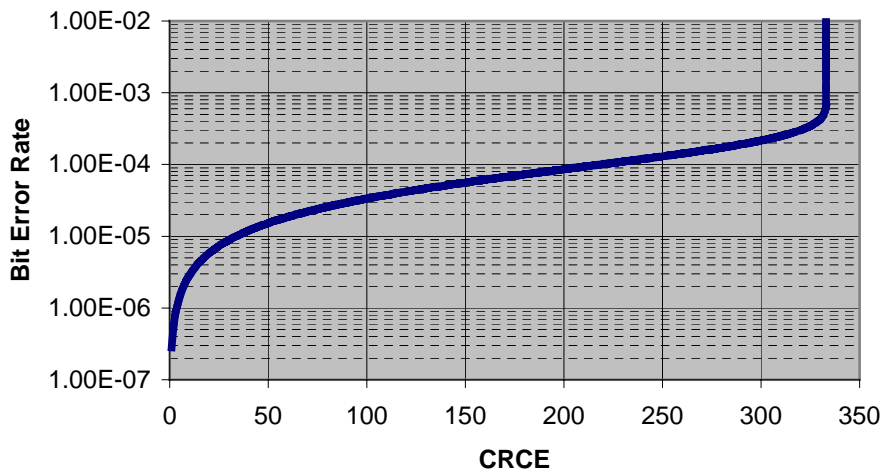
Since the maximum number of ESF superframes that can occur in one second is 333, the 9-bit BEE counter cannot saturate in one second in ESF framing format. Despite this, there is not a linear relationship between BER and BEE count, due to the nature of the CRC-6 calculation. At BERs below  $10^{-4}$ , there tends to be no more than one bit error per superframe, so the number of CRC-6 errors is generally equal to the number of bit errors, which is directly related to the BER. However, at BERs above  $10^{-4}$ , each CRC-6 error is often due to more than one

bit error. Thus, the relationship between BER and BEE count becomes non-linear above a  $10^{-4}$  BER. This must be taken into account when using ESF CRC-6 counts to determine the BER.

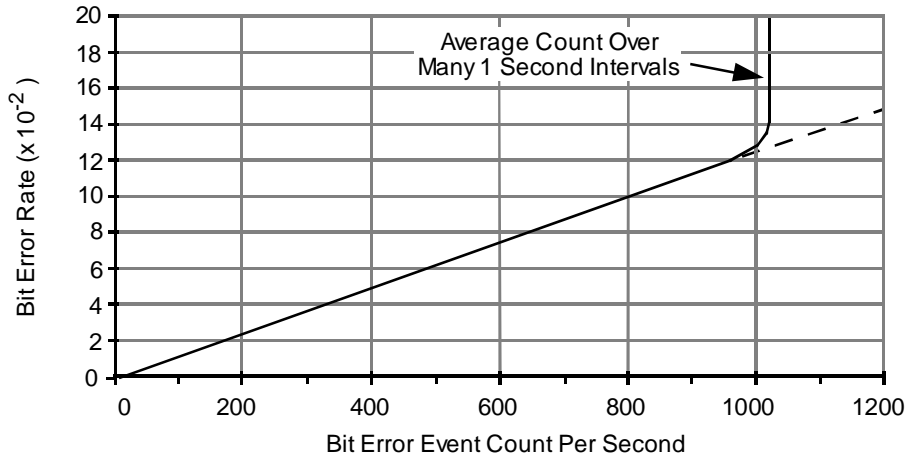
The bit error rate for T1 ESF can be calculated from the one-second PMON CRCE count by the following equation:

$$\text{Bit Error Rate} = 1 - 10^{\left( \frac{\log\left(1 - \frac{24}{8000} \text{BEE}\right)}{24 \cdot 193} \right)}$$

**Figure 21 - CRCE Count vs. BER (T1 ESF mode)**



For T1 SF format, the CRCE and FER counts are identical, but the FER counter is smaller and should be ignored.

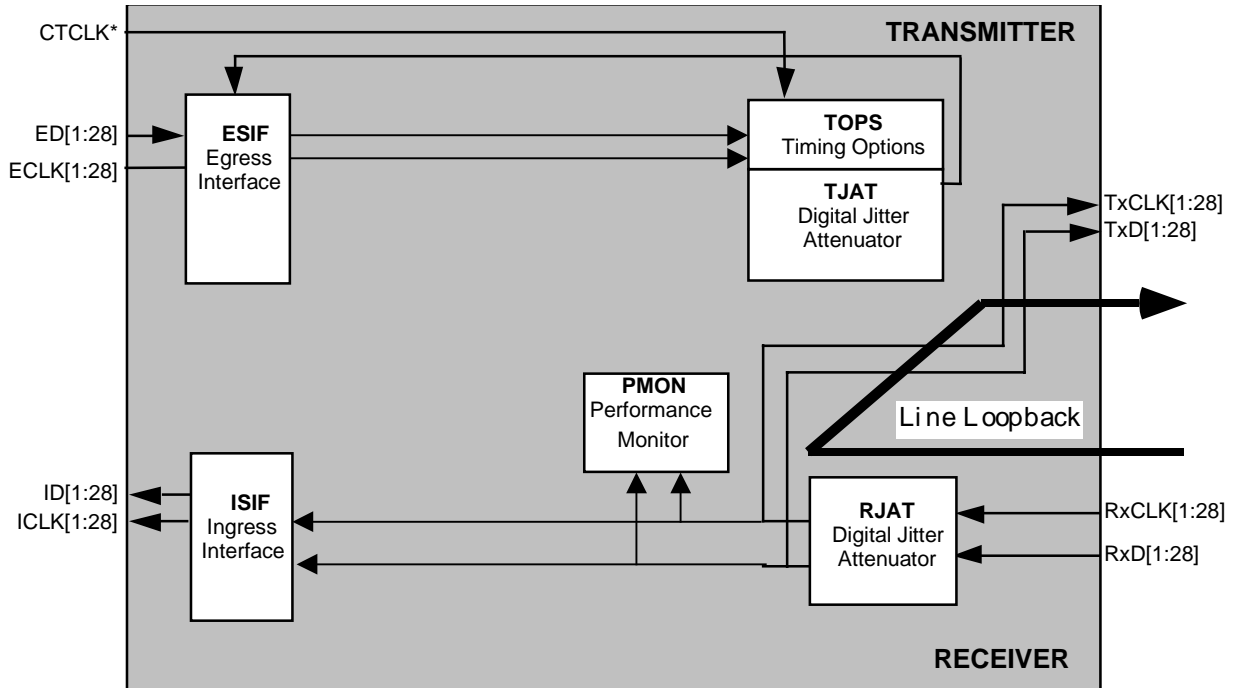
**Figure 22 - CRCE Count vs. BER (T1 SF mode)**


## **12.4 T1/E1 Stream Loopback Modes**

The TEMAP provides three loopback modes for T1/E1 links to aid in network and system diagnostics. The internal T1/E1 line loopback can be initiated at any time via the  $\mu$ P interface, but is usually initiated once an inband loopback activate code is detected. The system Diagnostic Digital loopback can be initiated at any time by the system via the  $\mu$ P interface to check the path of system data through the framer.

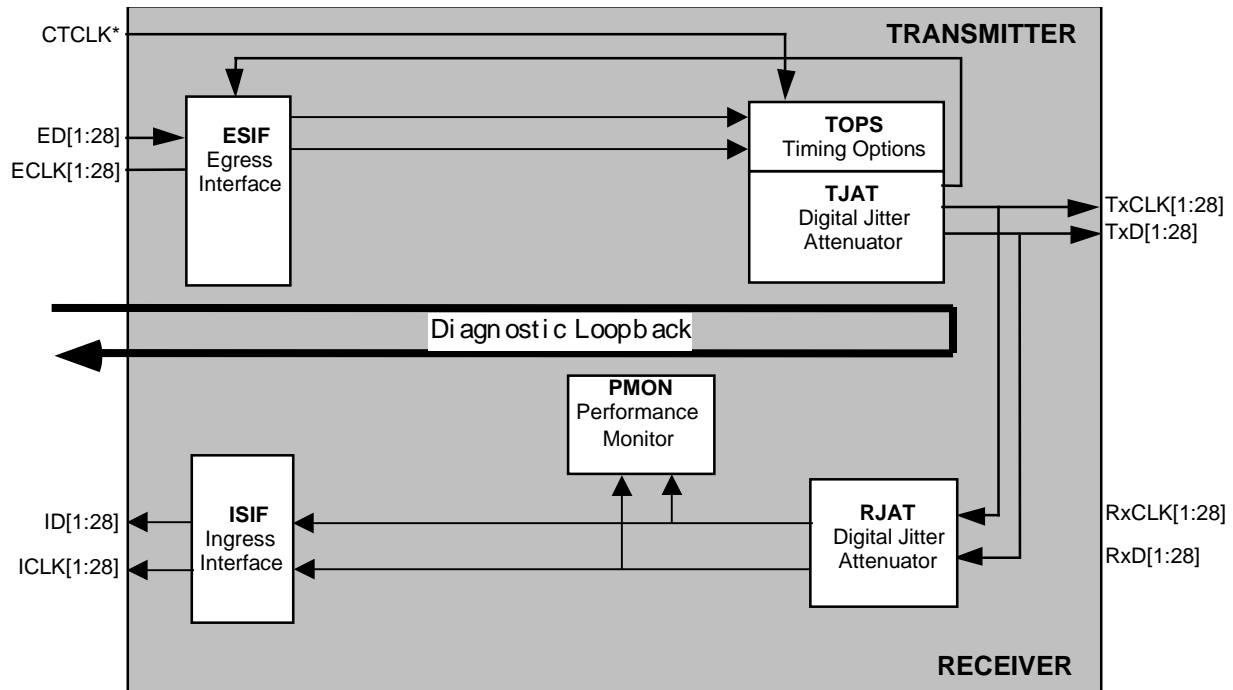
### **T1/E1 Line Loopback**

T1/E1 Line loopback is initiated by setting the LLOOP bit to a 1 in the T1/E1 Diagnostics register ( $000DH + N \times 80H$ ,  $N=1$  to 28). When in line loopback mode the appropriate T1/E1 streams in the TEMAP are configured to internally connect the jitter-attenuated clock and data from the RJAT to the transmit clock and data (shown as  $TxD[x]$  and  $TxCLK[x]$  in the lineloopback diagram) going to the M13 mux and SONET/SDH mapper. The RJAT may be bypassed if desired. Conceptually, the data flow through a single T1/E1 performance monitor block in this loopback condition is illustrated in Figure 23.

**Figure 23: T1/E1 Line Loopback**


### T1/E1 Diagnostic Digital Loopback

When Diagnostic Digital loopback is initiated, by writing a 1 to the DLOOP bit in the T1/E1 Diagnostics register (000DH + N\*80H, N=1 to 28), the appropriate T1/E1 stream in the TEMAP is configured to internally connect its transmit clock and data (shown as  $TxD[x]$  and  $TxCLK[x]$  in the diagnostic loopback figure) to the receive clock and data (shown as  $RxD[x]$  and  $RxCLK[x]$  in the diagnostic loopback figure). The data flow through a single T1/E1 performance monitoring block in this loopback condition is illustrated in Figure 24.

**Figure 24: T1/E1 Diagnostic Digital Loopback**


## 12.5 DS3 Loopback Modes

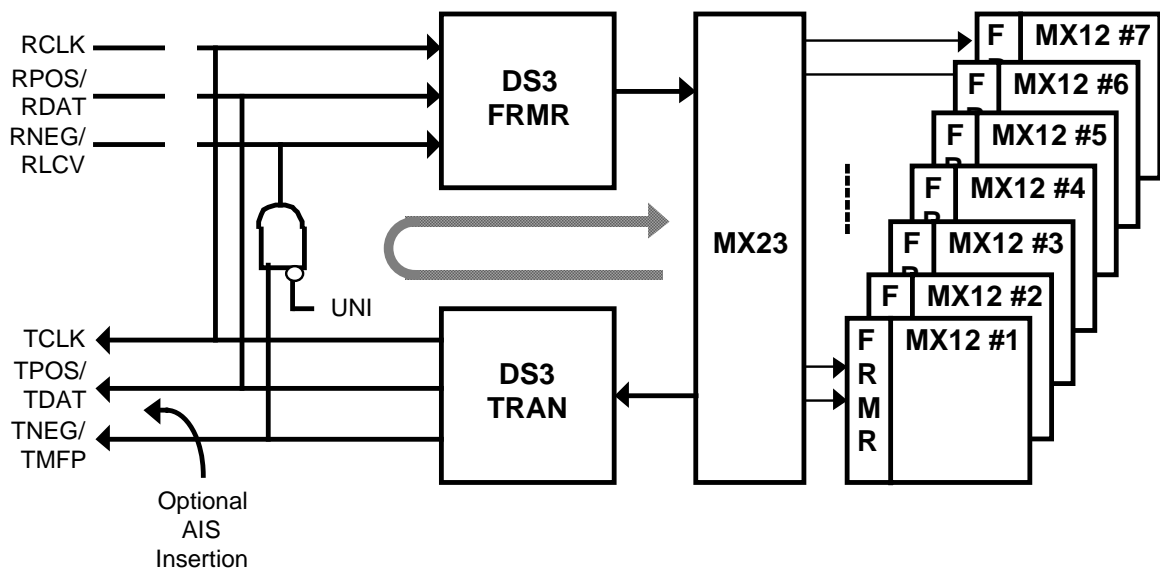
The TEMAP provides three DS3 M13 multiplexer loopback modes to aid in network and system diagnostics at the DS3 interface. The DS3 loopbacks can be initiated via the  $\mu$ P interface whenever the DS3 framer/M13 multiplexer is enabled. The DS3 Master Data Source register controls the DS3 loopback modes. These loopbacks are also available when the DS3 mux is used with the DS3 mapper via the telecom bus interface.

### DS3 Diagnostic Loopback

DS3 Diagnostic Loopback allows the transmitted DS3 stream to be looped back into the receive DS3 path, overriding the DS3 stream received on the RDAT/RPOS and RNEG/RLCV inputs. The RCLK signal is also substituted with the transmit DS3 clock, TCLK. While this mode is active, AIS may be substituted for the DS3 payload being transmitted on the TPOS/TDAT and TNEG/TMFP outputs. The configuration of the receive interface determines how the TNEG/TMFP signal is handled during loopback: if the UNI bit in the DS3 FRMR register is set, then the receive interface is configured for RDAT and RLCV, therefore the TNEG/TMFP signal is suppressed during loopback so that transmit MFP indications will not be seen nor accumulated as input LCVs. If the UNI bit is

clear, then the interface is configured for bipolar signals RPOS and RNEG, therefore the TNEG is fed directly to the RNEG input. This diagnostic loopback can be used when configured as a multiplexer or as a framer only. The DS3 loopback mode is shown diagrammatically in Figure 25.

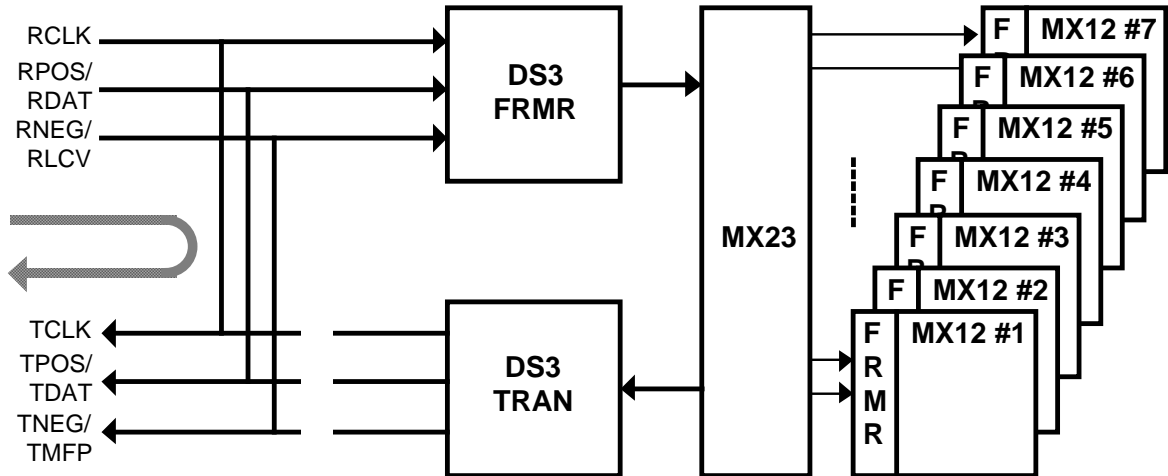
**Figure 25: DS3 Diagnostic Loopback Diagram**



### DS3 Line Loopback

DS3 Line Loopbacks allow the received DS3 streams to be looped back into the transmit DS3 paths, overriding the DS3 streams created internally by the multiplexing of the lower speed tributaries. The transmit signals on TPOS/TDAT and TNEG/TMFP are substituted with the receive signals on RPOS/RDAT and RNEG/RLCV. The TCLK signal is also substituted with the receive DS3 clock, RCLK. While this mode is active, AIS may be substituted for the DS3 payload being transmitted on the TPOS/TDAT and TNEG/TMFP outputs. Note that the transmit interface must be configured to be the same as the DS3 FRMR receive interface for this mode to work properly. The DS3 line loopback mode is shown diagrammatically in Figure 26. There is a second form of line loopback which only loops back the DS3 payload. In this mode the DS3 framing overhead is regenerated for the received DS3 stream and then retransmitted. Line loopback is selected with the LLOOP bit in the DS3 Master Data source register and payload loopback is selected by the PLOOP bit in the same register.

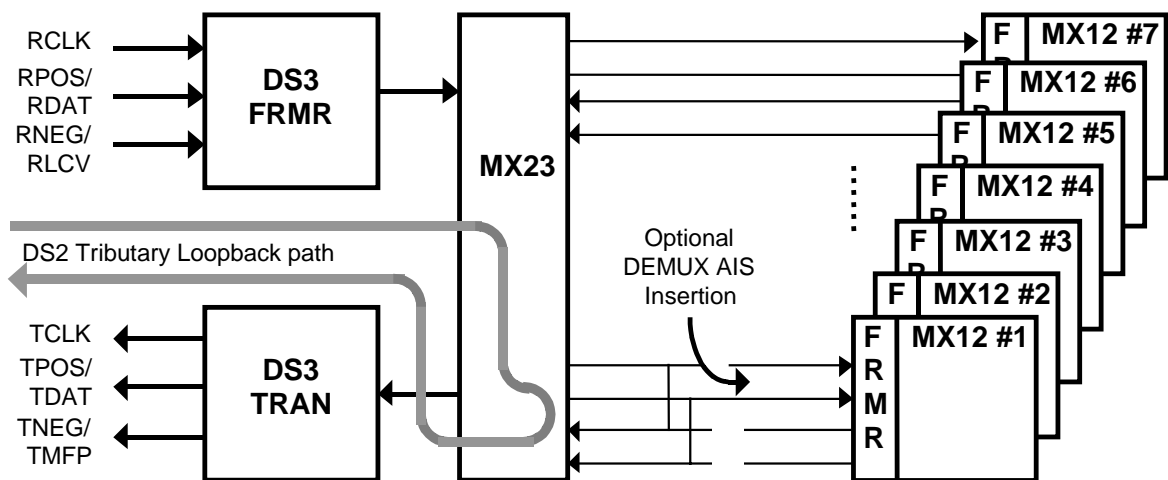
**Figure 26: DS3 Line Loopback Diagram**



**DS2 Demultiplex Loopback**

DS2 Demultiplex Loopbacks allow each of the seven demultiplexed DS2 streams to be looped back into the MX23 and multiplexed up into the transmit DS3 stream. This overrides the tributary DS2 streams coming from the MX12s. The DS2 loopback mode is shown diagrammatically in Figure 27 and is enabled via the MX23 Loopback Activate register.

**Figure 27: DS2 Loopback Diagram**



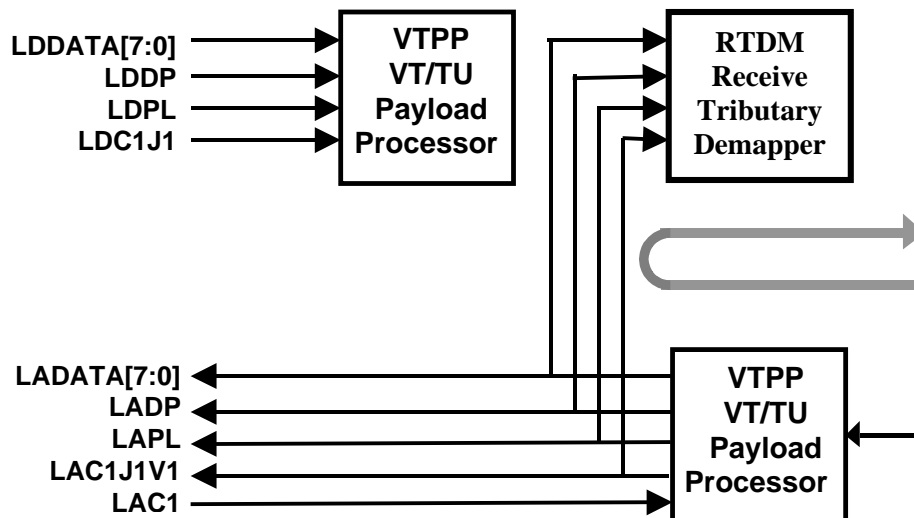
## 12.6 Telecom Bus Mapper/Demapper Loopback Modes

The TEMAP provides two loopbacks at the telecom bus interface to aid in network and system diagnostics at the SONET/SDH interface. These loopback modes can be enabled via the microprocessor whenever the SONET/SDH block is enabled as the mapper for the T1/E1 framer slices or as the mapper for the DS3 framer or M13 Multiplexer.

### Telecom Diagnostic Loopback

The Telecom Bus Diagnostic Loopback allows the transmitted telecom bus stream to be looped back into the receive SONET/SDH receive path, overriding the data stream received on the telecom drop bus inputs. While Telecom diagnostic loopback is active, valid SONET/SDH data continues to be transmitted on the telecom add bus outputs. The entire telecom drop bus is overwritten by the diagnostic loopback even though only one STS-1 SPE, STM-1/VC4 TUG3 or STM-1/VC3 is generated by the egress VTPP onto the telecom add bus. This loopback is only available for VT1.5/VT2/TU11/TU12 mapped tributaries. DS3 mapped tributaries must use the DS3 diagnostic loopback. The telecom bus diagnostic loopback mode is shown diagrammatically in Figure 28.

**Figure 28: Telecom Diagnostic Loopback Diagram**

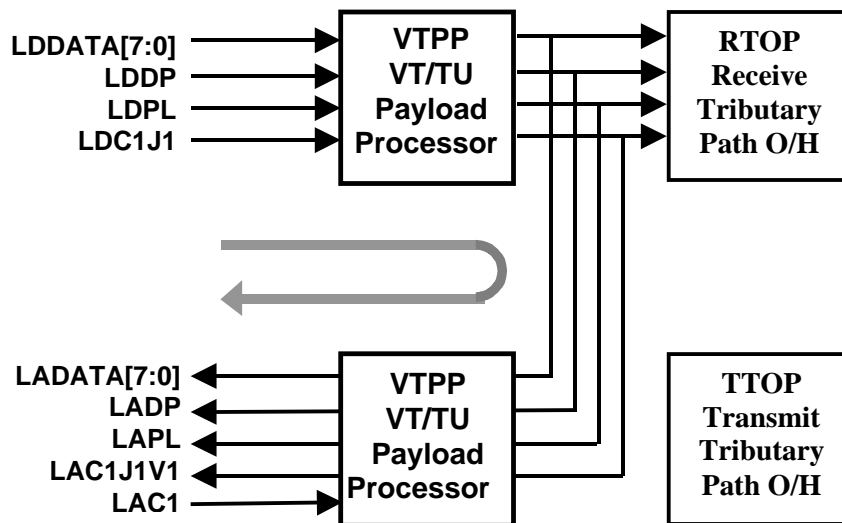


### Telecom Line Loopback

The Telecom Bus Line Loopback allows the received telecom drop bus data to be looped back out the telecom add bus after being processed by both the ingress and egress VTPPs. Both VTPPs must be setup for the same STS-1 SPE,

STM-1/VC4 TUG3 or STM-1/VC3 otherwise no loopback data will get through. The ingress data path is not affected by the telecom line loopback. This loopback is only available for VT1.5/VT2/TU11/TU12 mapped tributaries. DS3 mapped tributaries must use the DS3 line loopback. The Telecom bus line loopback mode is shown diagrammatically in Figure 29.

**Figure 29: Telecom Line Loopback Diagram**



## 12.7 SBI Bus Data Formats

The TEMAP uses the Scaleable Bandwidth Interconnect (SBI) bus as a high density link interconnect with devices processing T1s, E1s, DS3s and transparent virtual tributaries. The SBI bus is a multi-point to multi-point bus capable of interconnecting up to three TEMAP devices in parallel with other link layer or tributary processing devices.

### Multiplexing Structure

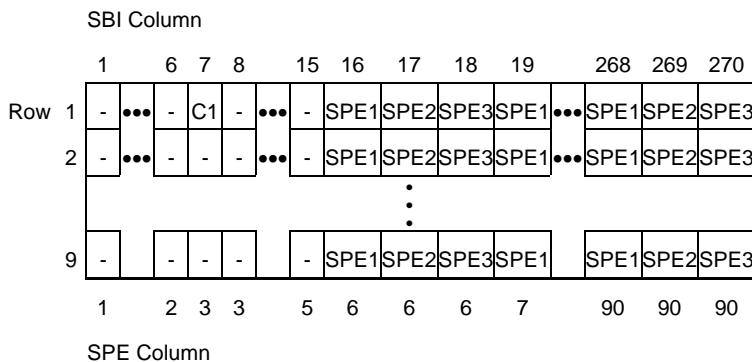
The SBI structure uses a locked SONET/SDH structure fixing the position of the TU-3 relative to the STS-3/STM-1. The SBI is also of fixed frequency and alignment as determined by the reference clock (SREFCLK) and frame indicator signal (SC1FP). Frequency deviations are compensated by adjusting the location of the T1/E1/DS3/TVT1.5/TVT2 channels using floating tributaries as determined by the V5 indicator and payload signals (SDV5, SAV5, SDPL and SAPL). TVTs also allow for synchronous operation where SONET/SDH tributary

pointers are carried within the SBI structure in place of the V5 indicator and payload signals (SDV5, SAV5, SDPL and SAPL).

Table 16 shows the bus structure for carrying T1, E1, TVT1.5, TVT2, DS3 and E3 tributaries in a SDH STM-1 like format. Up to 84 T1s, 63 E1s, 84 TVT1.5s, 63 TVT2s, 3 DS3s or 3 E3s are carried within the octets labeled SPE1, SPE2 and SPE3 in columns 16-270. All other octets are unused and are of fixed position. The frame signal (SC1FP) occurs during the octet labeled C1 in Row 1 column 7.

The multiplexed links are separated into three Synchronous Payload Envelopes called SPE1, SPE2 and SPE3. Each envelope carries up to 28 T1s, 21 E1, 28 TVT1.5s, 21 TVT2s, a DS3 or an E3. SPE1 carries the T1s numbered 1,1 through 1,28, E1s numbered 1,1 through 1,21, DS3 number 1,1 or E3 number 1,1. SPE2 carries T1s numbered 2,1 through 2,28, E1s numbered 2,1 through 2,21, DS3 number 2,1 or E3 number 2,1. SPE3 carries T1s numbered 3,1 through 3,28, E1s numbered 3,1 through 3,21, DS3 number 3,1 or E3 number 3,1. TVT1.5s are numbered the same as T1 tributaries and TVT2s are numbered the same as E1 tributaries. The most significant bit in all formats is the first bit of transmission.

**Table 16 - Structure for Carrying Multiplexed Links**



The TEMAP when enabled for SBI interconnection will add and drop either 28 T1s, 21 E1s or a DS3 into one of the three Synchronous Payload Envelopes, SPE1, SPE2 or SPE3. When T1 or E1 tributaries are sourced from the telecom bus via VT1.5, TU11, VT2 or TU12 mappings, the TEMAP also supports a mix of transparent virtual tributaries with T1s and E1s. Restriction to this are that only VT1.5s, TU11s and T1s can be mixed together or VT2s, TU12s and E1s can be mixed together. Another restriction is that the telecom bus and SBI bus must run from the same clock, ie. SREFCLK and LREFCLK are externally connected.

**Tributary Numbering**

Tributary numbering for T1 and E1 uses the SPE number, followed by the Tributary number within that SPE and are numbered sequentially. Table 17 and Table 18 show the T1 and E1 column numbering and relates the tributary number to the SPE column numbers and overall SBI column structure. Numbering for DS3 or E3 follows the same naming convention even though there is only one DS3 or E3 per SPE. TVT1.5s and TVT2s follow the same numbering conventions as T1 and E1 tributaries respectively. SBI columns 16-18 are unused for T1, E1, TVT1.5 and TVT2 tributaries.

**Table 17 – T1/TVT1.5 Tributary Column Numbering**

T1#	SPE1 Column	SPE2 Column	SPE3 Column	SBI Column
1,1	7,35,63			19,103,187
2,1		7,35,63		20,104,188
3,1			7,35,63	21,105,189
1,2	8,36,64			22,106,190
2,2		8,36,64		23,107,191
...				
1,28	34,62,90			100,184,268

2,28		34,62,90		101,185,269
3,28			34,62,90	102,186,270

**Table 18 - E1/TVT2 Tributary Column Numbering**

<b>E1#</b>	<b>SPE1 Column</b>	<b>SPE2 Column</b>	<b>SPE3 Column</b>	<b>SBI Column</b>
1,1	7,28,49,70			19,82,145,208
2,1		7,28,49,70		20,83,146,209
3,1			7,28,49,70	21,84,147,210
1,2	8,29,50,71			22,85,148,211
2,2		8,29,50,71		23,86,149,212
...				
1,21	27,48,69,90			79,142,205,268
2,21		27,48,69,90		80,143,206,269
3,21			27,48,69,90	81,144,207,270

### **SBI Timing Master Modes**

The TEMAP supports asynchronous SBI timing modes. Asynchronous modes allow T1, E1, DS3 and transparent tributaries to float within the SBI structure to accommodate differences in timing.

In Asynchronous modes timing is communicated across the Scaleable Bandwidth Interconnect by floating data structures within the SBI. Payload indicator signals in the SBI control the position of the floating data structure and therefore the timing. When sources are running faster than the SBI the floating payload structure is advanced by an octet by passing an extra octet in the V3 octet locations (H3 octet for DS3 mappings. When the source is slower than the SBI the floating payload is retarded by leaving the octet after the V3 or H3 octet unused. Both these rate adjustments are indicated by the SBI control signals.

Transparent VTs can float in the SBI structure in two ways. The first method uses valid V1 and V2 pointers to indicate positive and negative pointer justifications. The second method uses the SBI signals SDV5, SAV5, SDPL and SAPL to indicate rate adjustments. In the DROP bus the TEMAP will always provide both valid pointers with valid SDV5 and SDPL signals. On the SBI Add Bus the TEMAP needs to be configured on a per tributary basis for either transparent VT mode. Transparent VT operation is configured on a per tributary basis via the ETVT and ETVTPTRDIS bits in the TTMP Tributary control registers.

On the DROP BUS the TEMAP is timing master as determined by the arrival rate of data over the SBI.

On the ADD BUS the TEMAP can be either the timing master or the timing slave. When the TEMAP is the timing slave it receives its transmit timing information from the arrival rate of data across the SBI ADD bus. When the TEMAP is the timing master it signals devices on the SBI ADD bus to speed up or slow down with the justification request signal, SAJUST\_REQ. The TEMAP as timing master indicates a speedup request to a Link Layer SBI device by asserting the justification request signal high during the V3 or H3 octet. When this is detected by the Link Layer it will speed up the channel by inserting extra data in the next V3 or H3 octet. The TEMAP indicates a slowdown request to the Link Layer by asserting the justification request signal high during the octet after the V3 or H3 octet. When detected by the Link Layer it will retard the channel by leaving the octet following the next V3 or H3 octet unused. Both advance and retard rate adjustments take place in the frame or multi-frame following the justification request.

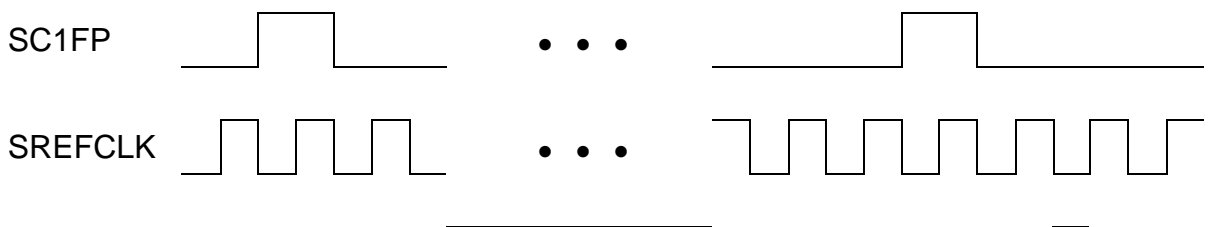
**SBI Link Rate Information**

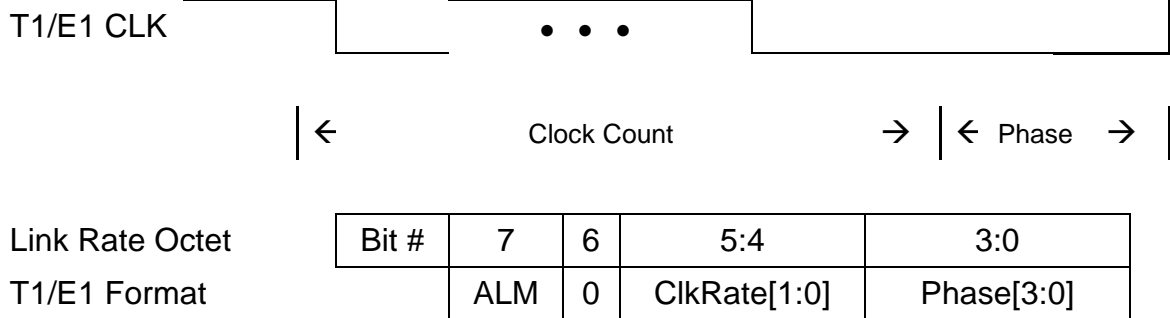
The TEMAP SBI bus provides a method for carrying link rate information between devices. This is optional on a per channel basis. Two methods are specified, one for T1 and E1 channels and the second for DS3 channels. Link rate information is not available for TVTs. These methods use the reference 19.44MHz SBI clock and the SC1FP frame synchronization signal to measure channel clock ticks and clock phase for transport across the bus.

The T1 and E1 method allows for a count of the number of T1 or E1 rising clock edges between 2 KHz SC1FP frame pulses. This count is encoded in ClkRate[1:0] to indicate that the nominal number of clocks, one more than nominal or one less than nominal should be generated during the SC1FP period. This method also counts the number of 19.44MHz clock rising edges after sampling SC1FP high to the next rising edge of the T1 or E1 clock, giving the ability to control the phase of the generated clock. The link rate information passed across the SBI bus via the V4 octet and is shown in Table 19.

Table 20 shows the encoding of the clock count, ClkRate[1:0], passed in the link rate octet.

**Table 19: SBI T1/E1 Link Rate Information**



**Table 20: SBI T1/E1 Clock Rate Encoding**

ClkRate[1:0]	T1 Clocks / 2KHz	E1 Clocks / 2 KHz
"00" – Nominal	772	1024
"01" – Fast	773	1025
"1x" – Slow	771	1023

The method for transferring DS3 link rate information across the SBI passes the encoded count of DS3 clocks between 2KHz SC1FP pulses in the same method used for T1/E1 tributaries, but does not pass any phase information. The other difference from T1/E1 link rate is that ClkRate[1:0] indicates whether the nominal number of clocks are generated or if four fewer or four extra clocks are generated during the SC1FP period. The format of the DS3 link rate octet is shown in Table 21. This is passed across the SBI via the Linkrate octet which follows the H3 octet in the column, see Table 25. Table 22 shows the encoding of the clock count, ClkRate[1:0], passed in the link rate octet.

**Table 21: DS3 Link Rate Information**

Link Rate Octet	Bit #	7	6	5:4	3:0
DS3 Format		0	0	ClkRate[1:0]	Unused

**Table 22: DS3 Clock Rate Encoding**

ClkRate[1:0]	DS3 Clocks / 2KHz
"00" – Nominal	22368
"01" – Fast	22372

"1x" – Slow	22364
-------------	-------

### **SBI Alarms**

The TEMUX transfers alarm conditions across the SBI bus for T1 and E1 tributaries. The TEMUX does not support alarm conditions across the SBI bus for DS3 nor transparent VTs.

Table 19 and Table 21 show the alarm indication bit, ALM, as bit 7 of the Link Rate Octet. Devices connecting to the TEMAP which do not support alarm indications must set this bit to 0 on the SBI ADD bus.

The presence of an alarm condition is indicated by the ALM bit set high in the Link Rate Octet. The absence of an alarm condition is indicated by the ALM bit set low in the Link Rate Octet. In the egress direction the TEMAP can be configured to use the alarm bit to force AIS on a per link basis.

### **T1 Tributary Mapping**

Table 23 shows the format for mapping 84 clear channel T1s within the SPE octets. The clear channel bits within each T1 are easily located within this mapping. The V1,V2 and V4 octets are not used to carry T1 data and are either reserved or used for control across the interface. When enabled, the V4 octet is the Link Rate octet of Tables 1 and 3. It carries alarm and clock phase information across the SBI bus. The V1 and V2 octets are unused and should be ignored by devices listening to the SBI bus. The V5 and R octets do not carry any information and are fixed to a zero value. The V3 octet carries a T1 data octet but only during rate adjustments as indicated by the V5 indicator signals, DV5 and AV5, and payload signals, SDPL and SAPL.

The V1,V2,V3 and V4 octets are fixed to the locations shown. All the other octets, shown shaded for T1#1,1, float within the allocated columns maintaining the same order and moving a maximum of one octet per 2KHz multi-frame. The position of the floating T1 is identified via the V5 Indicator signals, SDV5 and SAV5, which locate the V5 octet. When the T1 tributary rate is faster than the SBI nominal T1 tributary rate, the T1 tributary is shifted ahead by one octet which is compensated by sending an extra octet in the V3 location. When the T1 tributary rate is slower than the nominal SBI tributary rate the T1 tributary is shifted by one octet which is compensated by inserting a stuff octet in the octet immediately following the V3 octet and delaying the octet that was originally in that position.

**Table 23 - T1 Framing Format**

COL #	T1#1,1	T1#2,1-3,28	T1#1,1	T1#2,1-3,28	T1#1,1	T1#2,1-3,28
-------	--------	-------------	--------	-------------	--------	-------------

ROW #	1-18	19	20-102	103	104-186	187	188-270
1	Unused	V1	V1	V5	-	PPSSSSIR	-
2	Unused		-		-		-
3	Unused		-		-		-
4	Unused		-		-		-
5	Unused		-		-		-
6	Unused		-		-		-
7	Unused		-		-		-
8	Unused		-		-		-
9	Unused		-		-		-
1	Unused	V2	V2	R	-	PPSSSSIR	-
2	Unused		-		-		-
3	Unused		-		-		-
4	Unused		-		-		-
5	Unused		-		-		-
6	Unused		-		-		-
7	Unused		-		-		-
8	Unused		-		-		-
9	Unused		-		-		-
1	Unused	V3	V3	R	-	PPSSSSIR	-
2	Unused		-		-		-
3	Unused		-		-		-
4	Unused		-		-		-
5	Unused		-		-		-
6	Unused		-		-		-
7	Unused		-		-		-
8	Unused		-		-		-
9	Unused		-		-		-
1	Unused	V4	V4	R	-	PPSSSSIR	-
2	Unused		-		-		-
3	Unused		-		-		-
4	Unused		-		-		-
5	Unused		-		-		-
6	Unused		-		-		-
7	Unused		-		-		-
8	Unused		-		-		-
9	Unused		-		-		-

The P<sub>1</sub>P<sub>0</sub>S<sub>1</sub>S<sub>2</sub>S<sub>3</sub>S<sub>4</sub>I<sub>R</sub> octet carries one bit of the clear channel T1 stream in the I bit. The R, P and S bits are unused.

T1 tributary asynchronous timing is compensated via the V3 octet. T1 tributary link rate adjustments are optionally passed across the SBI via the V4. T1 tributary alarm conditions are optionally passed across the SBI bus via the link rate octet in the V4 location.

### E1 Tributary Mapping

Table 24 shows the format for mapping 63 clear channel E1s within the SPE octets. The I bits carry the clear channel E1 bits. The V1, V2 and V4 octets are not used to carry E1 data and are either reserved used for control information across the interface. When enabled, the V4 octet carries clock phase information across the SBI. The V1 and V2 octets are unused and should be ignored by devices listening to the SBI bus. The V5 and R octets do not carry any information and are fixed to a zero value. The V3 octet carries an E1 data octet but only during rate adjustments as indicated by the V5 indicator signals, SDV5 and SAV5, and payload signals, SDPL and SAPL.

The V1, V2, V3 and V4 octets are fixed to the locations shown. All the other octets, shown shaded for E1#1,1, float within the allocated columns maintaining the same order and moving a maximum of one octet per 2KHz multi-frame. The position of the floating E1 is identified via the V5 Indicator signals, SDV5 and SAV5, which locate the V5 octet. When the E1 tributary rate is faster than the E1 tributary nominal rate, the E1 tributary is shifted ahead by one octet which is compensated by sending an extra octet in the V3 location. When the E1 tributary rate is slower than the nominal rate the E1 tributary is shifted by one octet which is compensated by inserting a stuff octet in the octet immediately following the V3 octet and delaying the octet that was originally in that position.

**Table 24 – E1 Framing Format**

	COL #	E1#1,1	#2,1-3,21	E1#1,1	#2,1-3,21	E1#1,1	#2,1-3,21	E1#1,1	#2,1-3,21
ROW #	1-18	19	20-81	82	83-144	145	146-207	208	209-270
1	Unused	V1	V1	V5	-	PP	-	I	-
2	Unused	I	-	I	-	I	-	I	-
3	Unused	I	-	I	-	I	-	I	-
4	Unused	I	-	I	-	I	-	I	-
5	Unused	I	-	I	-	I	-	I	-
6	Unused	I	-	I	-	I	-	I	-
7	Unused	I	-	I	-	I	-	I	-
8	Unused	I	-	I	-	I	-	I	-

9	Unused	I	-	I	-	I	-	R	-
1	Unused	V2	V2	R	-	PP	-	I	-
2	Unused	I	-	I	-	I	-	I	-
3	Unused	I	-	I	-	I	-	I	-
4	Unused	I	-	I	-	I	-	I	-
5	Unused	I	-	I	-	I	-	I	-
6	Unused	I	-	I	-	I	-	I	-
7	Unused	I	-	I	-	I	-	I	-
8	Unused	I	-	I	-	I	-	I	-
9	Unused	I	-	I	-	I	-	R	-
1	Unused	V3	V3	R	-	PP	-	I	-
2	Unused	I	-	I	-	I	-	I	-
3	Unused	I	-	I	-	I	-	I	-
4	Unused	I	-	I	-	I	-	I	-
5	Unused	I	-	I	-	I	-	I	-
6	Unused	I	-	I	-	I	-	I	-
7	Unused	I	-	I	-	I	-	I	-
8	Unused	I	-	I	-	I	-	I	-
9	Unused	I	-	I	-	I	-	R	-
1	Unused	V4	V4	R	-	PP	-	I	-
2	Unused	I	-	I	-	I	-	I	-
3	Unused	I	-	I	-	I	-	I	-
4	Unused	I	-	I	-	I	-	I	-
5	Unused	I	-	I	-	I	-	I	-
6	Unused	I	-	I	-	I	-	I	-
7	Unused	I	-	I	-	I	-	I	-
8	Unused	I	-	I	-	I	-	I	-
9	Unused	I	-	I	-	I	-	R	-

E1 tributary asynchronous timing is compensated via the V3 octet. E1 tributary link rate adjustments are optionally passed across the SBI via the V4 octet. E1 tributary alarm conditions are optionally passed across the SBI bus via the link rate octet in the V4 location.

**DS3 Tributary Mapping**

Table 25 shows a DS3 tributary mapped within the first synchronous payload envelope SPE1. The V5 indicator pulse identifies the V5 octet. The DS3 framing format does not follow an 8KHz frame period so the floating DS3 multi-frame located by the V5 indicator, shown in heavy border grey region in Table 25, will

jump around relative to the H1 frame on every pass. In fact the V5 indicator will often be asserted twice per H1 frame, as is shown by the second V5 octet in Table 25. The V5 indicator and payload signals indicate negative and positive rate adjustments which are carried out by either putting a data byte in the H3 octet or leaving empty the octet after the H3 octet.

**Table 25 - DS3 Framing Format**

	SPE COL #		DS3 1	DS3 2-56	DS3 57	DS3 58-84	DS3 Col 85
ROW	SBI COL.# 1,4,7,10	13	16	...	184	...	268
1	Unused	H1	V5	DS3	DS3	DS3	DS3
2	Unused	H2	DS3	DS3	DS3	DS3	DS3
3	Unused	H3	DS3	DS3	DS3	DS3	DS3
4	Unused	Linkrate	DS3	DS3	DS3	DS3	DS3
5	Unused	Unused	DS3	DS3	DS3	DS3	DS3
6	Unused	Unused	DS3	DS3	DS3	DS3	DS3
7	Unused	Unused	DS3	DS3	DS3	DS3	DS3
8	Unused	Unused	DS3	DS3	V5	DS3	DS3
9	Unused	Unused	DS3	DS3	DS3	DS3	DS3

Because the DS3 tributary rate is less than the rate of the grey region, padding octets are interleaved with the DS3 tributary to make up the difference in rate. Interleaved with every DS3 multi-frame are 35 stuff octets, one of which is the V5 octet. These 35 stuff octets are spread evenly across seven DS3 subframes. Each DS3 subframe is eight blocks of 85 bits. The 85 bits making up a DS3 block are padded out to be 11 octets. Table 26 shows the DS3 block 11 octet format where R indicates a stuff bit, F indicates a DS3 framing bit and I indicates DS3 information bits. Table 27 shows the DS3 multi-frame format that is packed into the grey region of Table 25. In this table V5 indicates the V5 octet which is also a stuff octet, R indicates a stuff octet and B indicates the 11 octet DS3 block. Each row in Table 27 is a DS3 multi-frame. The DS3 multi-frame stuffing format is identical for 5 multi-frames and then an extra stuff octet after the V5 octet is added every sixth frame.

**Table 26 - DS3 Block Format**

Octet #	1	2	3	4	5	6	7	8	9	10	11
Data	RRRFIIII	8*I	8*I	8*I	8*I	8*I	8*I	8*I	8*I	8*I	8*I

**Table 27 - DS3 Multi-frame Stuffing Format**

V5	4*R	8*B	5*R	8*B	5*R	8*B	5*R	8*B	5*R	8*B	5*R	8*B	5*R	8*B
----	-----	-----	-----	-----	-----	-----	-----	-----	-----	-----	-----	-----	-----	-----

V5	4*R	8*B	5*R	8*B	5*R	8*B	5*R	8*B	5*R	8*B	5*R	8*B	5*R	8*B
V5	4*R	8*B	5*R	8*B	5*R	8*B	5*R	8*B	5*R	8*B	5*R	8*B	5*R	8*B
V5	4*R	8*B	5*R	8*B	5*R	8*B	5*R	8*B	5*R	8*B	5*R	8*B	5*R	8*B
V5	4*R	8*B	5*R	8*B	5*R	8*B	5*R	8*B	5*R	8*B	5*R	8*B	5*R	8*B
V5	5*R	8*B	5*R	8*B	5*R	8*B	5*R	8*B	5*R	8*B	5*R	8*B	5*R	8*B

DS3 asynchronous timing is compensated via the H3 octet. DS3 link rate adjustments are optionally passed across the SBI via the Linkrate octet. DS3 link rate adjustments are optionally passed across the SBI bus via the Linkrate octet.

### Transparent VT1.5/TU11 Mapping

VT1.5 and TU11 virtual tributaries, TVT1.5s, are transported across the SBI bus in a similar manner to the T1 tributary mapping. Table 28 shows the transparent structure where “I” is used to indicate information bytes. There are two options when carrying virtual tributaries on the SBI bus, the primary difference being how the floating V5 payload is located.

The first option is locked TVT mode which carries the entire VT1.5/TU11 virtual tributary indicated by the shaded region in Table 28. Locked is used to indicate that the location of the V1,V2 pointer is locked. The virtual tributary must have a valid V1,V2 pointer to locate the V5 payload. In this mode the V5 indicator and payload signals, SDV5, SAV5, SDPL and SAPL, may be generated but must be ignored by the receiving device. In locked mode timing is always sourced by the transmitting side, therefore justification requests are not used and the SAJUST\_REQ signal is ignored. Other than the V1 and V2 octets which must carry valid pointers, all octets can carry data in any format. The location of the V1,V2,V3 and V4 octets is fixed to the locations shown in Table 28.

The second option is floating TVT mode which carries the payload comprised of the V5 and I octets within the shaded region of Table 28. In this mode the V1,V2 pointers are still in a fixed location and may be valid but are ignored by the receiving device. The V5 indicator and payload signals, SDV5, SAV5, SDPL and SAPL, must be valid and are used to locate the floating payload. The justification request signal can be used to control the timing on the add bus. The location of the V1,V2,V3 and V4 octets is fixed to the locations shown in Table 28.

The TEMAP supports both TVT modes simultaneously in the SBI DROP bus and is configurable on a per tributary basis in the SBI ADD bus.

**Table 28 - Transparent VT1.5/TU11 Format**

COL #	VT1.5#1,1	#2,1-3,28	VT1.5#1,1	#2,1-3,28	VT1.5#1,1	#2,1-3,28
-------	-----------	-----------	-----------	-----------	-----------	-----------

ROW #	1-18	19	20-102	103	104-186	187	188-270
1	Unused	V1	V1	V5	-		-
2	Unused		-		-		-
3	Unused		-		-		-
4	Unused		-		-		-
5	Unused		-		-		-
6	Unused		-		-		-
7	Unused		-		-		-
8	Unused		-		-		-
9	Unused		-		-		-
1	Unused	V2	V2		-		-
2	Unused		-		-		-
3	Unused		-		-		-
4	Unused		-		-		-
5	Unused		-		-		-
6	Unused		-		-		-
7	Unused		-		-		-
8	Unused		-		-		-
9	Unused		-		-		-
1	Unused	V3	V3		-		-
2	Unused		-		-		-
3	Unused		-		-		-
4	Unused		-		-		-
5	Unused		-		-		-
6	Unused		-		-		-
7	Unused		-		-		-
8	Unused		-		-		-
9	Unused		-		-		-
1	Unused	V4	V4		-		-
2	Unused		-		-		-
3	Unused		-		-		-
4	Unused		-		-		-
5	Unused		-		-		-
6	Unused		-		-		-
7	Unused		-		-		-
8	Unused		-		-		-
9	Unused		-		-		-

## Transparent VT2/TU12 Mapping

VT2 and TU12 virtual tributaries, TVT2s, are transported across the SBI bus in a similar manner to the E1 tributary mapping. The TEMAP supports both TVT modes simultaneously in the SBI DROP bus and is configurable on a per tributary basis in the SBI ADD bus.

Table 29 shows the transparent structure where “I” is used to indicate information bytes. There are two options when carrying virtual tributaries on the SBI bus, the primary difference being how the floating V5 payload is located.

The first option is locked TVT mode which carries the entire VT2/TU12 virtual tributary indicated by the shaded region in Table 29.

Locked is used to indicate that the location of the V1,V2 pointer is locked. The virtual tributary must have a valid V1,V2 pointer to locate the V5 payload. In this mode the V5 indicator and payload signals, SDV5, SAV5, SDPL and SAPL, are optionally generated but must be ignored by the receiving device. In locked mode timing is always sourced by the transmitting side, therefore justification requests are not used and the SAJUST\_REQ signal is ignored. Other than the V1 and V2 octets which are carrying valid pointers, all octets can carry data in any format. The location of the V1,V2,V3 and V4 octets is fixed to the locations shown in Table 29.

The second option is floating TVT mode which carries the payload comprised of the V5 and I octets within the shaded region of Table 29. In this mode the V1,V2 pointers are still in a fixed location and may be valid but are ignored by the receiving device. The V5 indicator and payload signals, SDV5, SAV5, SDPL and SAPL, must be valid and are used to locate the floating payload. The justification request signal can be used to control the timing on the add bus. The location of the V1,V2,V3 and V4 octets is fixed to the locations shown in Table 29.

The TEMAP supports both TVT modes simultaneously in the SBI DROP bus and is configurable on a per tributary basis in the SBI ADD bus.

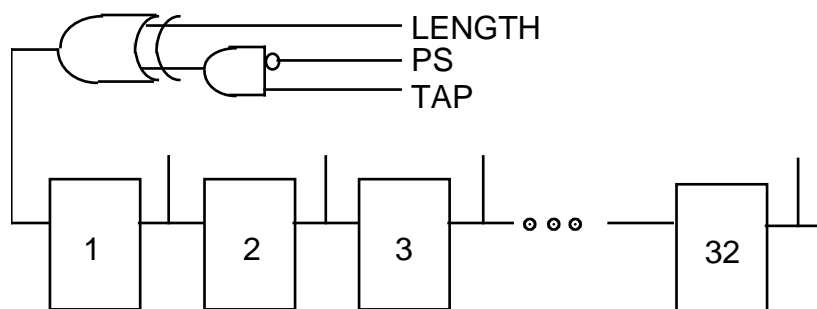
**Table 29 – Transparent VT2/TU12 Format**

	COL #	E1#1,1	#2,1-3,21	E1#1,1	#2,1-3,21	E1#1,1	#2,1-3,21	E1#1,1	#2,1-3,21
ROW #	1-18	19	20-81	82	83-144	145	146-207	208	209-270
1	Unused	V1	V1	V5	-	I	-	I	-
2	Unused	I	-	I	-	I	-	I	-
3	Unused	I	-	I	-	I	-	I	-
4	Unused	I	-	I	-	I	-	I	-
5	Unused	I	-	I	-	I	-	I	-

6	Unused		-		-		-		-
7	Unused		-		-		-		-
8	Unused		-		-		-		-
9	Unused		-		-		-		-
1	Unused	V2	V2		-		-		-
2	Unused		-		-		-		-
3	Unused		-		-		-		-
4	Unused		-		-		-		-
5	Unused		-		-		-		-
6	Unused		-		-		-		-
7	Unused		-		-		-		-
8	Unused		-		-		-		-
9	Unused		-		-		-		-
1	Unused	V3	V3		-		-		-
2	Unused		-		-		-		-
3	Unused		-		-		-		-
4	Unused		-		-		-		-
5	Unused		-		-		-		-
6	Unused		-		-		-		-
7	Unused		-		-		-		-
8	Unused		-		-		-		-
9	Unused		-		-		-		-
1	Unused	V4	V4		-		-		-
2	Unused		-		-		-		-
3	Unused		-		-		-		-
4	Unused		-		-		-		-
5	Unused		-		-		-		-
6	Unused		-		-		-		-
7	Unused		-		-		-		-
8	Unused		-		-		-		-
9	Unused		-		-		-		-

**12.8 PRGD Pattern Generation**

The pattern generator can be configured to generate pseudo random patterns or repetitive patterns as shown in Figure 30 below:

**Figure 30: PRGD Pattern Generator**


The pattern generator consists of a 32 bit shift register and a single XOR gate. The XOR gate output is fed into the first stage of the shift register. The XOR gate inputs are determined by values written to the length register (PL[4:0]) and the tap register (PT[4:0], when the PS bit is low). When PS is high, the pattern detector functions as a recirculating shift register, with length determined by PL[4:0].

### **Generating and detecting repetitive patterns**

When a repetitive pattern (such as 1-in-8) is to be generated or detected, the PS bit must be set to logic 1. The pattern length register must be set to (N-1), where N is the length of the desired repetitive pattern. Several examples of programming for common repetitive sequences are given below in the Common Test Patterns section.

For pattern generation, the desired pattern must be written into the PRGD Pattern Insertion registers. The repetitive pattern will then be continuously generated. The generated pattern will be inserted in the output data stream, but the phase of the pattern cannot be guaranteed.

For pattern detection, the PRGD will determine if a repetitive pattern of the length specified in the pattern length register exists in the input stream. It does so by loading the first N bits from the data stream, and then monitoring to see if the pattern loaded repeats itself error free for the subsequent 48 bit periods. It will repeat this process until it finds a repetitive pattern of length N, at which point it begins counting errors (and possibly re-synchronizing) in the same way as for pseudo-random sequences. Note that the PRGD does NOT look for the pattern loaded into the Pattern Insertion registers, but rather automatically detects any repetitive pattern of the specified length. The precise pattern detected can be determined by initiating a PRGD update, setting PDR[1:0] = 00 in the PRGD Control register, and reading the Pattern Detector registers (which will then contain the 32 bits detected immediately prior to the strobe).

## **Common Test Patterns**

The PRGD can be configured to monitor the standardized pseudo random and repetitive patterns described in ITU-T O.151. The register configurations required to generate these patterns and others are indicated in Table 30 and Table 31 below:

**Table 30: Pseudo Random Pattern Generation (PS bit = 0)**

Pattern Type	TR	LR	IR#1	IR#2	IR#3	IR#4	TINV	RINV
2 <sup>3</sup> -1	00	02	FF	FF	FF	FF	0	0
2 <sup>4</sup> -1	00	03	FF	FF	FF	FF	0	0
2 <sup>5</sup> -1	01	04	FF	FF	FF	FF	0	0
2 <sup>6</sup> -1	04	05	FF	FF	FF	FF	0	0
2 <sup>7</sup> -1	00	06	FF	FF	FF	FF	0	0
2 <sup>7</sup> -1 (Fractional T1 LB Activate)	03	06	FF	FF	FF	FF	0	0
2 <sup>7</sup> -1 (Fractional T1 LB Deactivate)	03	06	FF	FF	FF	FF	1	1
2 <sup>9</sup> -1 (O.153)	04	08	FF	FF	FF	FF	0	0
2 <sup>10</sup> -1	02	09	FF	FF	FF	FF	0	0
2 <sup>11</sup> -1 (O.152, O.153)	08	0A	FF	FF	FF	FF	0	0
2 <sup>15</sup> -1 (O.151)	0D	0E	FF	FF	FF	FF	1	1
2 <sup>17</sup> -1	02	10	FF	FF	FF	FF	0	0
2 <sup>18</sup> -1	06	11	FF	FF	FF	FF	0	0
2 <sup>20</sup> -1 (O.153)	02	13	FF	FF	FF	FF	0	0
2 <sup>20</sup> -1 (O.151 QRSS bit=1)	10	13	FF	FF	FF	FF	0	0
2 <sup>21</sup> -1	01	14	FF	FF	FF	FF	0	0
2 <sup>22</sup> -1	00	15	FF	FF	FF	FF	0	0
2 <sup>23</sup> -1 (O.151)	11	16	FF	FF	FF	FF	1	1
2 <sup>25</sup> -1	02	18	FF	FF	FF	FF	0	0
2 <sup>28</sup> -1	02	1B	FF	FF	FF	FF	0	0
2 <sup>29</sup> -1	01	1C	FF	FF	FF	FF	0	0
2 <sup>31</sup> -1	02	1E	FF	FF	FF	FF	0	0

**Table 31: Repetitive Pattern Generation (PS bit = 1)**

Pattern Type	TR	LR	IR#1	IR#2	IR#3	IR#4	TINV	RINV
All ones	00	00	FF	FF	FF	FF	0	0
All zeros	00	00	FE	FF	FF	FF	0	0
Alternating ones/zeros	00	01	FE	FF	FF	FF	0	0
Double alternating ones/zeros	00	03	FC	FF	FF	FF	0	0
3 in 24	00	17	22	00	20	FF	0	0
1 in 16	00	0F	01	00	FF	FF	0	0
1 in 8	00	07	01	FF	FF	FF	0	0
1 in 4	00	03	F1	FF	FF	FF	0	0
Inband loopback activate	00	04	F0	FF	FF	FF	0	0
Inband loopback deactivate	00	02	FC	FF	FF	FF	0	0

## Notes for the Pseudo Random and Repetitive Pattern Generation Tables

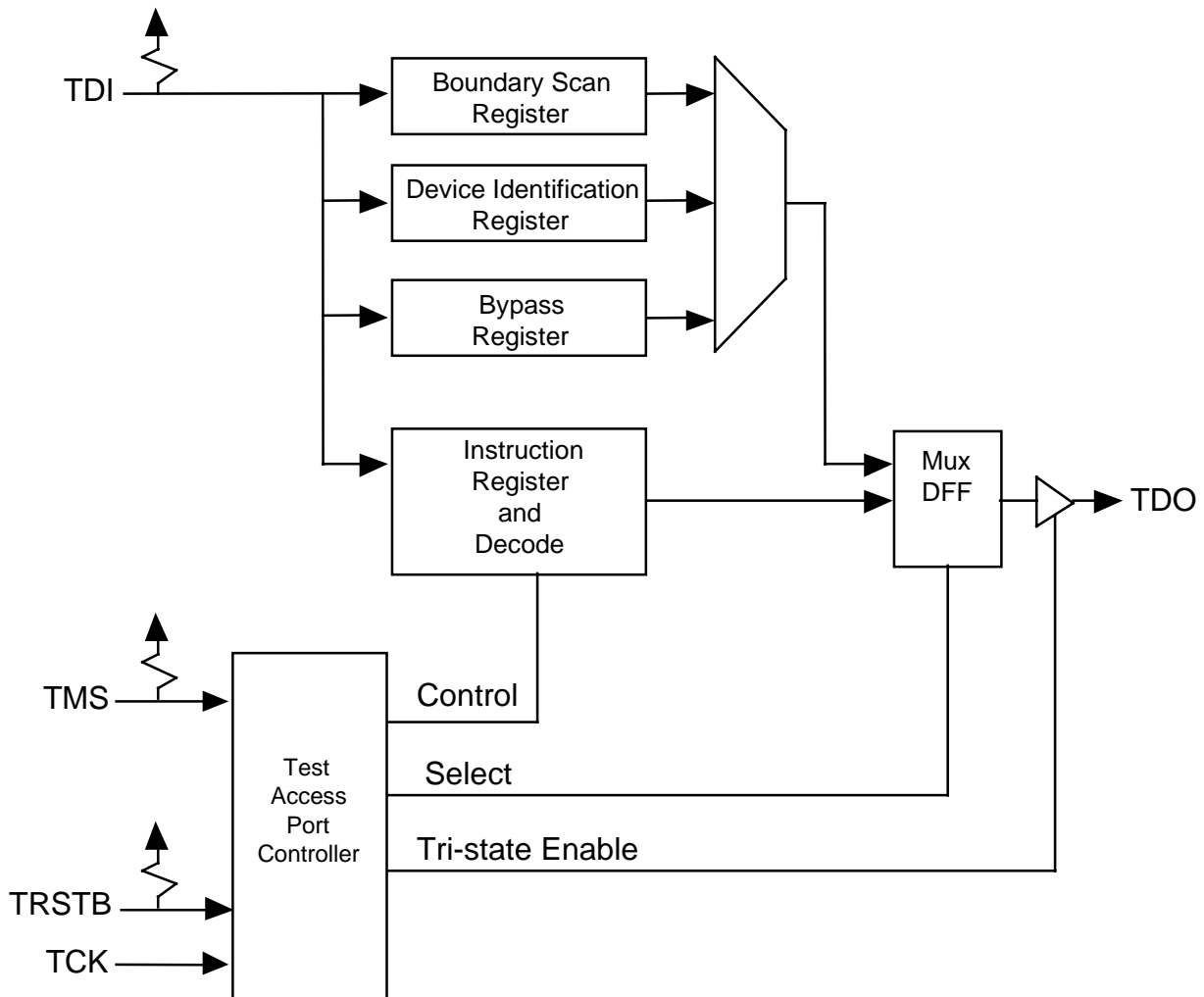
1. The PS bit and the QRSS bit are contained in the PRGD Control register
2. TR = PRGD Tap Register
3. LR = PRGD Length Register
4. IR#1 = PRGD Pattern Insertion #1 Register
5. IR#2 = PRGD Pattern Insertion #2 Register
6. IR#3 = PRGD Pattern Insertion #3 Register
7. IR#4 = PRGD Pattern Insertion #4 Register
8. The TINV bit and the RINV bit are contained in the PRGD Control register

**12.9 JTAG Support**

The TEMAP supports the IEEE Boundary Scan Specification as described in the IEEE 1149.1 standards. The Test Access Port (TAP) consists of the five

standard pins, TRSTB, TCK, TMS, TDI and TDO used to control the TAP controller and the boundary scan registers. The TRSTB input is the active-low reset signal used to reset the TAP controller. TCK is the test clock used to sample data on input, TDI and to output data on output, TDO. The TMS input is used to direct the TAP controller through its states. The basic boundary scan architecture is shown below.

**Figure 31: Boundary Scan Architecture**



The boundary scan architecture consists of a TAP controller, an instruction register with instruction decode, a bypass register, a device identification register and a boundary scan register. The TAP controller interprets the TMS input and generates control signals to load the instruction and data registers. The instruction register with instruction decode block is used to select the test to be executed and/or the register to be accessed. The bypass register offers a single-

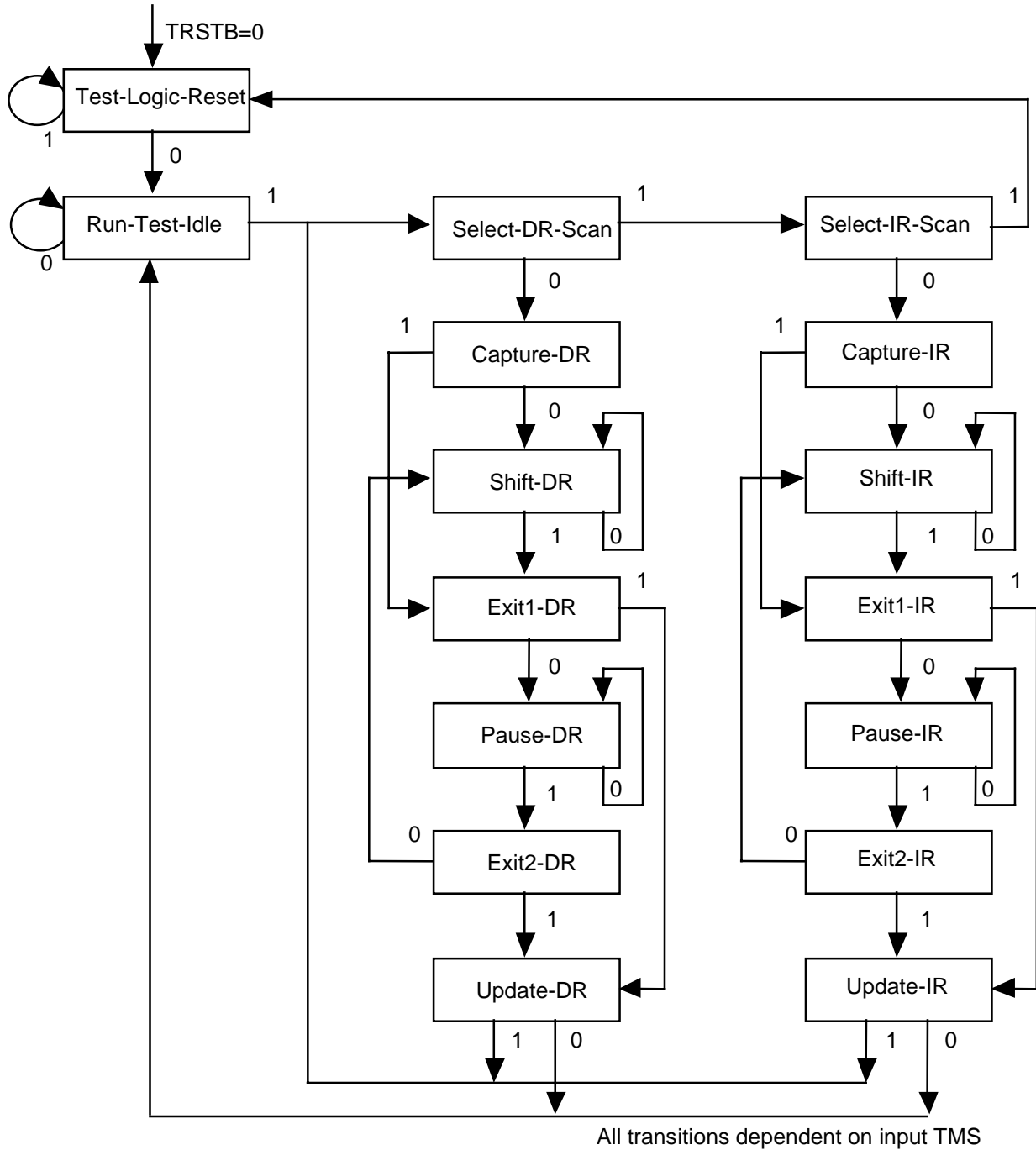
bit delay from primary input, TDI to primary output, TDO. The device identification register contains the device identification code.

The boundary scan register allows testing of board inter-connectivity. The boundary scan register consists of a shift register placed in series with device inputs and outputs. Using the boundary scan register, all digital inputs can be sampled and shifted out on primary output, TDO. In addition, patterns can be shifted in on primary input, TDI, and forced onto all digital outputs.

### **12.9.1 TAP Controller**

The TAP controller is a synchronous finite state machine clocked by the rising edge of primary input, TCK. All state transitions are controlled using primary input, TMS. The finite state machine is described below.

**Figure 32: TAP Controller Finite State Machine**



## Test-Logic-Reset

The test logic reset state is used to disable the TAP logic when the device is in normal mode operation. The state is entered asynchronously by asserting input, TRSTB. The state is entered synchronously regardless of the current TAP controller state by forcing input, TMS high for 5 TCK clock cycles. While in this state, the instruction register is set to the IDCODE instruction.

## Run-Test-Idle

The run test/idle state is used to execute tests.

## Capture-DR

The capture data register state is used to load parallel data into the test data registers selected by the current instruction. If the selected register does not allow parallel loads or no loading is required by the current instruction, the test register maintains its value. Loading occurs on the rising edge of TCK.

## Shift-DR

The shift data register state is used to shift the selected test data registers by one stage. Shifting is from MSB to LSB and occurs on the rising edge of TCK.

## Update-DR

The update data register state is used to load a test register's parallel output latch. In general, the output latches are used to control the device. For example, for the EXTEST instruction, the boundary scan test register's parallel output latches are used to control the device's outputs. The parallel output latches are updated on the falling edge of TCK.

## Capture-IR

The capture instruction register state is used to load the instruction register with a fixed instruction. The load occurs on the rising edge of TCK.

## Shift-IR

The shift instruction register state is used to shift both the instruction register and the selected test data registers by one stage. Shifting is from MSB to LSB and occurs on the rising edge of TCK.

## Update-IR

The update instruction register state is used to load a new instruction into the instruction register. The new instruction must be scanned in using the Shift-IR state. The load occurs on the falling edge of TCK.

The Pause-DR and Pause-IR states are provided to allow shifting through the test data and/or instruction registers to be momentarily paused.

## Boundary Scan Instructions

The following is a description of the standard instructions. Each instruction selects a serial test data register path between input, TDI and output, TDO.

### **BYPASS**

The bypass instruction shifts data from input, TDI to output, TDO with one TCK clock period delay. The instruction is used to bypass the device.

### **EXTEST**

The external test instruction allows testing of the interconnection to other devices. When the current instruction is the EXTEST instruction, the boundary scan register is placed between input, TDI and output, TDO. Primary device inputs can be sampled by loading the boundary scan register using the Capture-DR state. The sampled values can then be viewed by shifting the boundary scan register using the Shift-DR state. Primary device outputs can be controlled by loading patterns shifted in through input TDI into the boundary scan register using the Update-DR state.

### **SAMPLE**

The sample instruction samples all the device inputs and outputs. For this instruction, the boundary scan register is placed between TDI and TDO. Primary device inputs and outputs can be sampled by loading the boundary scan register using the Capture-DR state. The sampled values can then be viewed by shifting the boundary scan register using the Shift-DR state.

### **IDCODE**

The identification instruction is used to connect the identification register between TDI and TDO. The device's identification code can then be shifted out using the Shift-DR state.

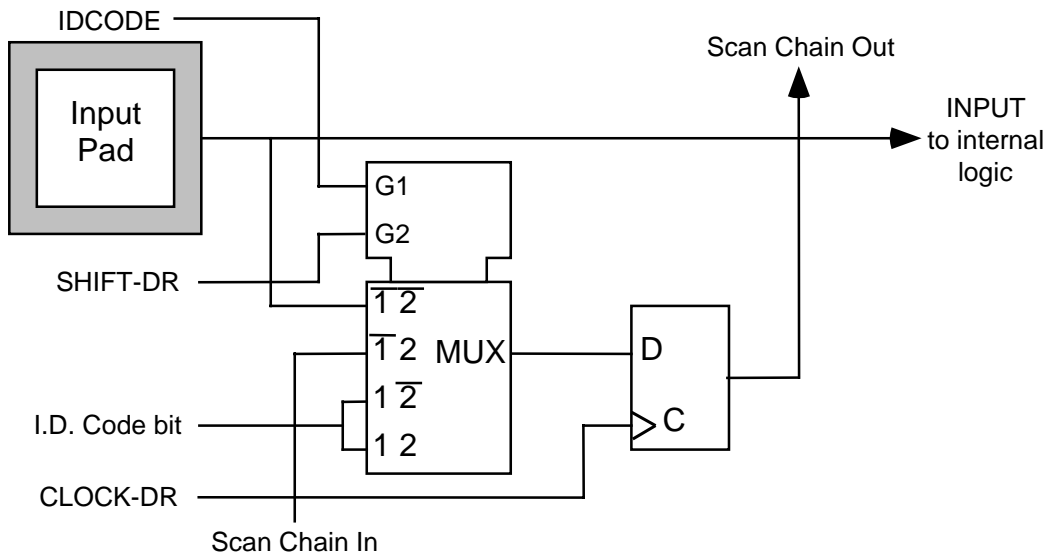
## STCTEST

The single transport chain instruction is used to test out the TAP controller and the boundary scan register during production test. When this instruction is the current instruction, the boundary scan register is connected between TDI and TDO. During the Capture-DR state, the device identification code is loaded into the boundary scan register. The code can then be shifted out of the output, TDO, using the Shift-DR state.

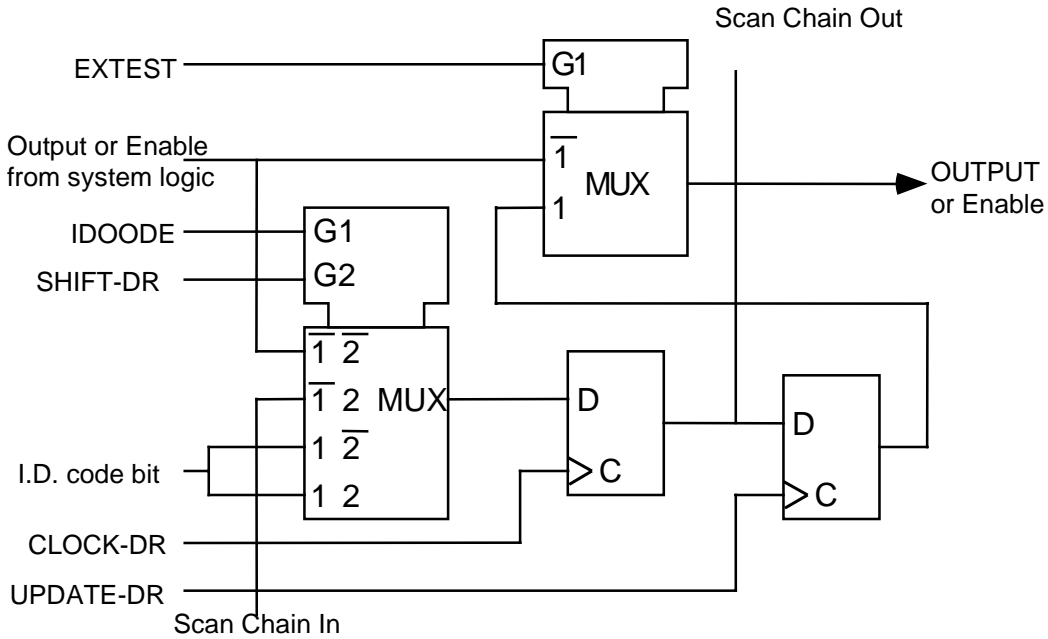
### Boundary Scan Cells

In the following diagrams, CLOCK-DR is equal to TCK when the current controller state is SHIFT-DR or CAPTURE-DR, and unchanging otherwise. The multiplexer in the center of the diagram selects one of four inputs, depending on the status of select lines G1 and G2. The ID Code bit is as listed in the Boundary Scan Register table in the JTAG Test Port section 11.2.

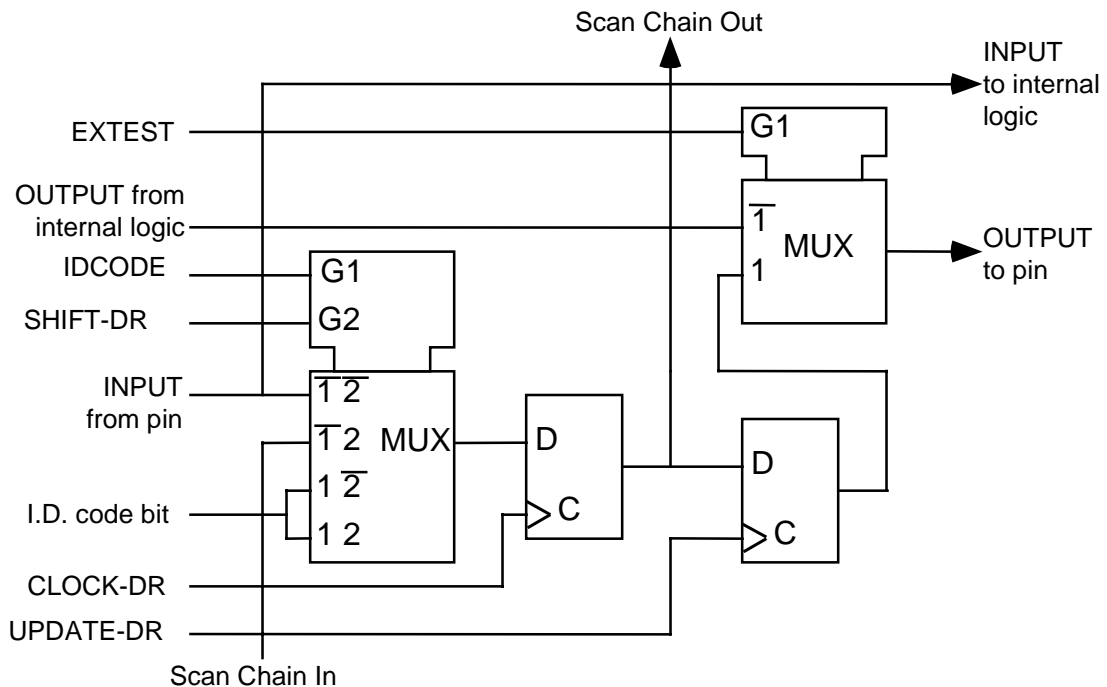
**Figure 33: Input Observation Cell (IN\_CELL)**



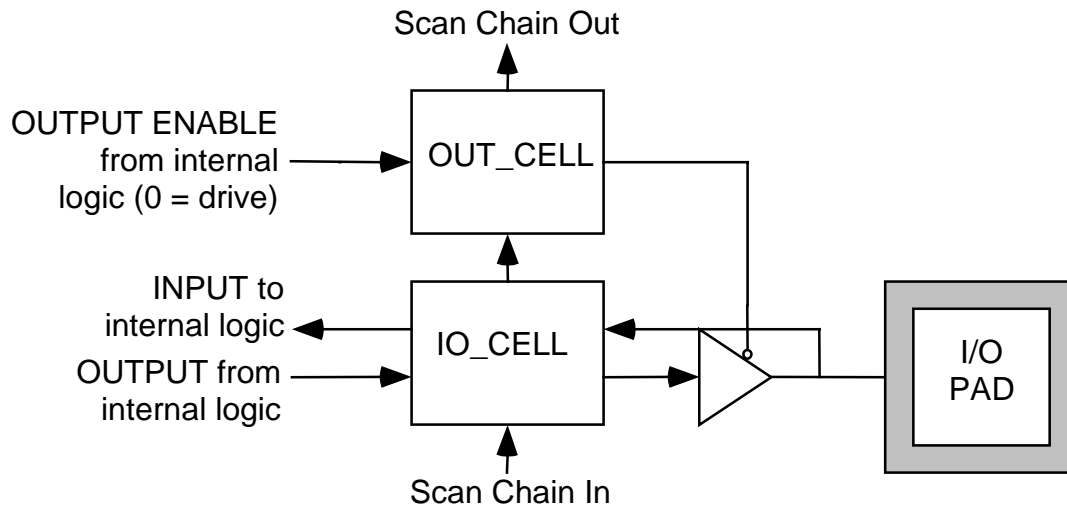
**Figure 34: Output Cell (OUT\_CELL)**



**Figure 35: Bidirectional Cell (IO\_CELL)**



**Figure 36: Layout of Output Enable and Bidirectional Cells**

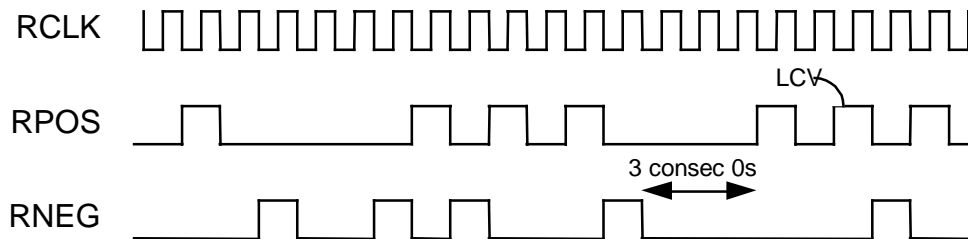


## 13 FUNCTIONAL TIMING

### 13.1 DS3 Line Side Interface Timing

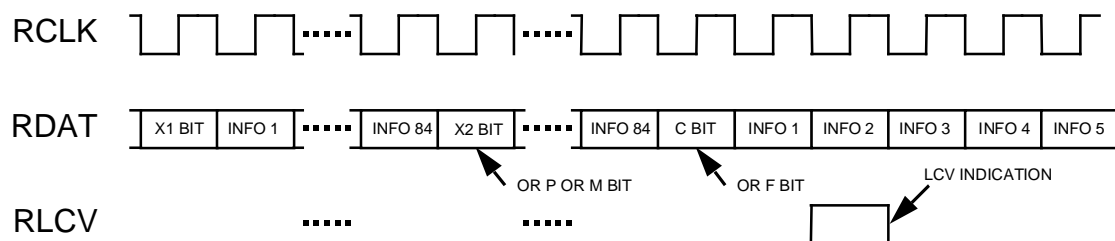
All functional timing diagrams assume that polarity control is not being applied to input and output data and clock lines (i.e. polarity control bits in the TEMAP registers are set to their default states).

**Figure 37: Receive Bipolar DS3 Stream**



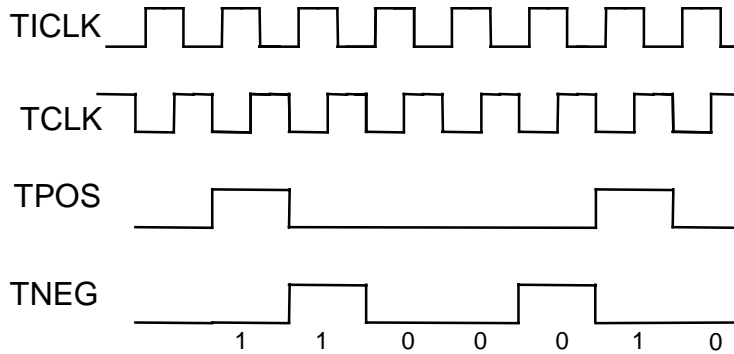
The Receive Bipolar DS3 Stream diagram (Figure 37) shows the operation of the TEMAP while processing a B3ZS encoded DS3 stream on inputs RPOS and RNEG. It is assumed that the first bipolar violation (on RNEG) illustrated corresponds to a valid B3ZS signature. A line code violation is declared upon detection of three consecutive zeros in the incoming stream, or upon detection of a bipolar violation which is not part of a valid B3ZS signature.

**Figure 38: Receive Unipolar DS3 Stream**



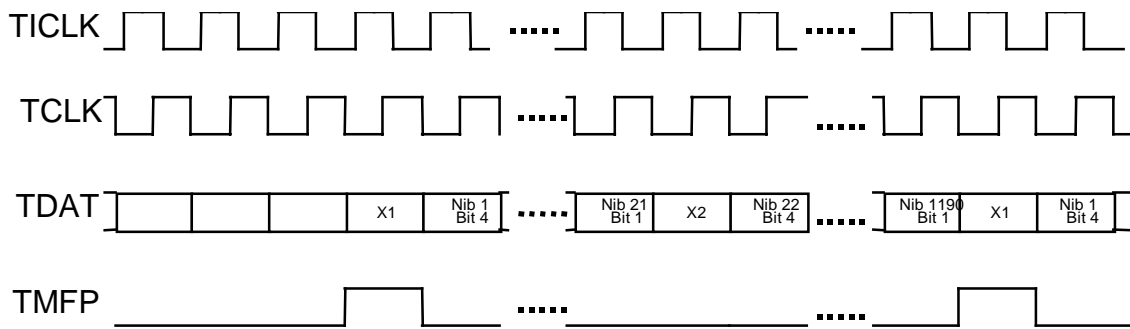
The Receive Unipolar DS3 Stream diagram (Figure 38) shows the complete DS3 receive signal on the RDAT input. Line code violation indications, detected by an upstream B3ZS decoder, are indicated on input RLCV. RLCV is sampled each bit period. The PMON Line Code Violation Event Counter is incremented each time a logic 1 is sampled on RLCV.

**Figure 39: Transmit Bipolar DS3 Stream**



The Transmit Bipolar DS3 Stream diagram (Figure 39) illustrates the generation of a bipolar DS3 stream. The B3ZS encoded DS3 stream is present on TPOS and TNEG. These outputs, along with the transmit clock, TCLK, can be directly connected to a DS3 line interface unit. Note that TCLK is a flow through version of TICLK; a variable propagation delay exists between these two signals.

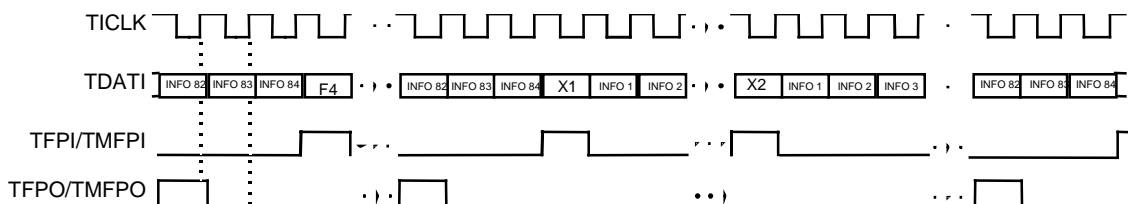
**Figure 40: Transmit Unipolar DS3 Stream**

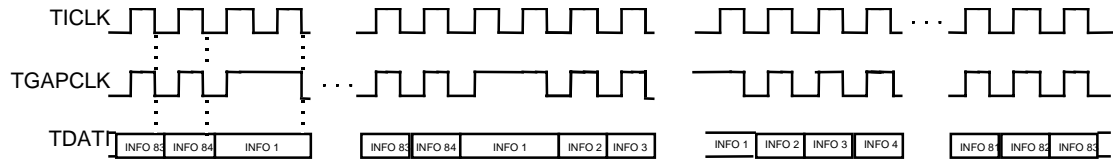


The Transmit Unipolar DS3 Stream diagram (Figure 40) illustrates the unipolar DS3 stream generation. The TMFP output marks the M-frame boundary, X1 bit, in the transmit stream. Note that TCLK is a flow through version of TICLK; a variable propagation delay exists between these two signals.

**13.2 DS3 System Side Interface Timing**

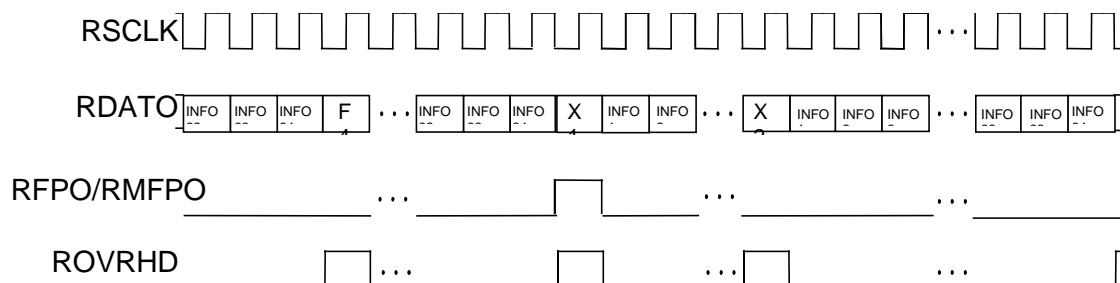
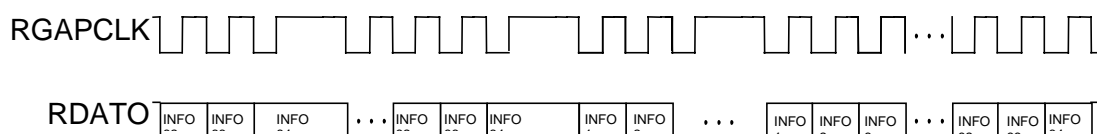
**Figure 41: Framers Mode DS3 Transmit Input Stream**



**Figure 42: Framer Mode DS3 Transmit Input Stream With TGAPCLK**


The Framer Mode DS3 Transmit Input Stream diagram (Figure 41) shows the expected format of the inputs TDATI and TFPI/TMFPI along with TICLK and the output TFPO/TMFPO when the OPMODE[1:0] bits are set to “DS3 Framer Only mode” in the Global Configuration register. If the TXMFPI bit in the DS3 Master Unchannelized Interface Options register is logic 0, then TFPI is valid, and the TEMAP will expect TFPI to pulse for every DS3 overhead bit with alignment to TDATI. If the TXMFPI register bit is logic 1, then TMFPI is valid, and the TEMAP will expect TMFPI to pulse once every DS3 M-frame with alignment to TDATI. If the TXMFPO bit in the DS3 Master Unchannelized Interface Options register is logic 0, then TFPO is valid, and the TEMAP will pulse TFPO once every 85 TICLK cycles, providing upstream equipment with a reference DS3 overhead pulse. If the TXMFPO register bit is logic 1, then TMFPO is valid and the TEMAP will pulse TMFPO once every 4760 TICLK cycles, providing upstream equipment with a reference M-frame pulse. The alignment of TFPO or TMFPO is arbitrary. There is no set relationship between TFPO/TMFPO and TFPI/TMFPI. When the DS3 interface is loop timed by setting the LOOPT bit in the DS3 Master Data Source register, RCLK replaces TICLK as the transmit timing reference and all timing is relative to RCLK.

The TGAPCLK output is available in place of TFPO/TMFPO when the TXGAPEN bit in the DS3 Master Unchannelized Interface Options register is set to logic 1, as in Figure 42. TGAPCLK remains high during the overhead bit positions. TDATI is sampled on the active edge of TGAPCLK when TXGAPEN is set to logic 1 and on the active edge of TICLK when TXGAPEN is set to logic 0. The TDATIFALL bit in the DS3 Master Unchannelized Interface Options register selects the active edge of TICLK or TGAPCLK for sampling TDATI.

**Figure 43: Framer Mode DS3 Receive Output Stream**

**Figure 44: Framer Mode DS3 Receive Output Stream with RGAPCLK**


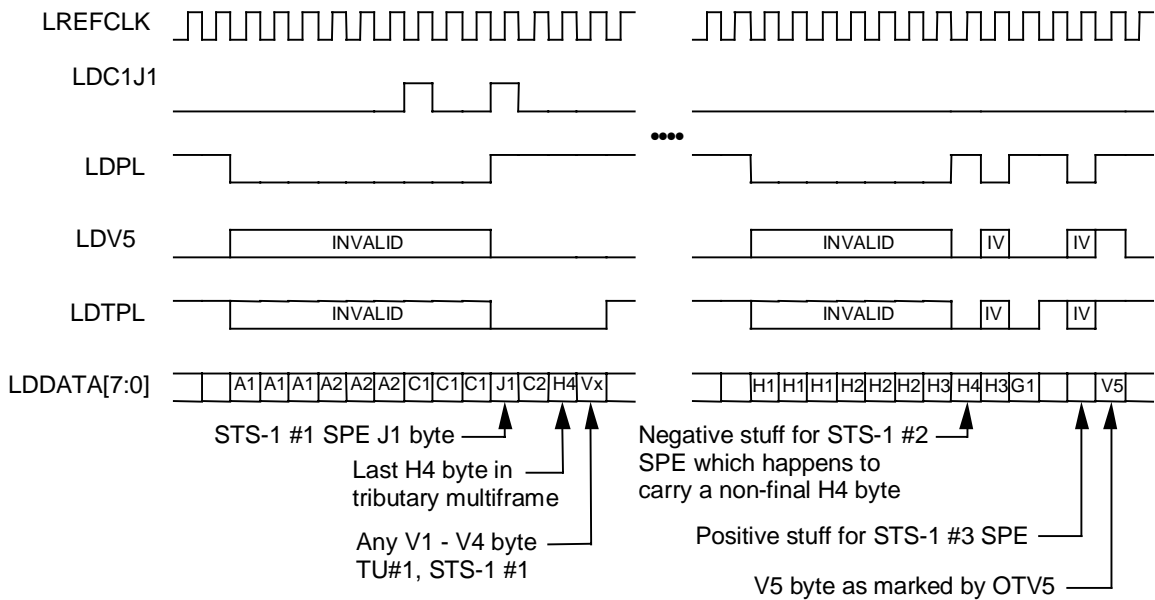
The DS3 Framer Only Mode Receive Output Stream diagram (Figure 43) shows the format of the outputs RDATO, RFPO/RMFPO, RSCLK ROVRHD when the OPMODE[1:0] bits are set to “DS3 Framer Only mode” in the Global Configuration register. Figure 43 shows the data streams when the TEMAP is configured for the DS3 receive format. If the RXMFPO bit in the DS3 Master Unchannelized Interface Options register is logic 0, RFPO is valid and will pulse high for one RSCLK cycle on first bit of each M-subframe with alignment to the RDATO data stream. If the RXMFPO register bit is a logic 1 (as shown Figure 43), RMFPO is valid and will pulse high on the X1 bit of the RDATO data output stream. ROVRHD will be high for every overhead bit position on the RDATO data stream. Figure 44 shows the output data stream with RGAPCLK in place of RSCLK when the RXGAPEN bit in the DS3 Master Unchannelized Interface Options register set to logic 1. RGAPCLK remains high during the overhead bit positions.

### **13.3 Telecom DROP Bus Interface Timing**

Figure 45 shows the function of the various telecom DROP bus signals in AU3 mode. Data on LDDATA[7:0] is sampled on the rising edge of LREFCLK. The bytes forming the three STS-1 synchronous payload envelopes are identified when the LDPL signal is high. In this diagram, a negative stuff event is shown occurring on STS-1 #2 and a positive stuff event on STS-1 #3. The LDC1J1V1 signal pulses high, while LDPL is set low, to mark the C1 byte of the first STS-1 in every frame of the STS-3 transport envelope. The LDC1J1V1 signal is high when the LDPL signal is high to mark every J1 byte of each of the three STS-1

SPEs. The bytes forming the various tributary synchronous payload envelopes are identified by the LDTPL when set high. The LDV5 signal pulses high to mark the V5 bytes of each outgoing tributaries. LDTPL and LDV5 are invalid when LDPL is set low. The three STS-1 SPEs can each have different alignments to the STS-3 transport envelope and the alignment is changing for two of the STS-1 SPEs (STS-1 #2 and #3) due to the pointer justification events shown.

**Figure 45: Telecom DROP Bus Timing - STS-1 SPEs / AU3 VCs**



The LDV5 and LDTPL signals are optional when using the ingress VTPP within the TEMAP which will regenerate the LDV5 and LDTPL signals from LDC1J1V1, LDPL and the pointers within LDDATA[7:0]. In order to bypass the ingress VTPP, the data on the Telecom drop bus must be locked such that all three STS-1 SPEs are aligned to the STS-3 transport envelope with the J1 bytes immediately following the C1 bytes. This is shown in Figure 46.

**Figure 46: Telecom DROP Bus Timing - Locked STS-1 SPEs / AU3 VCs**

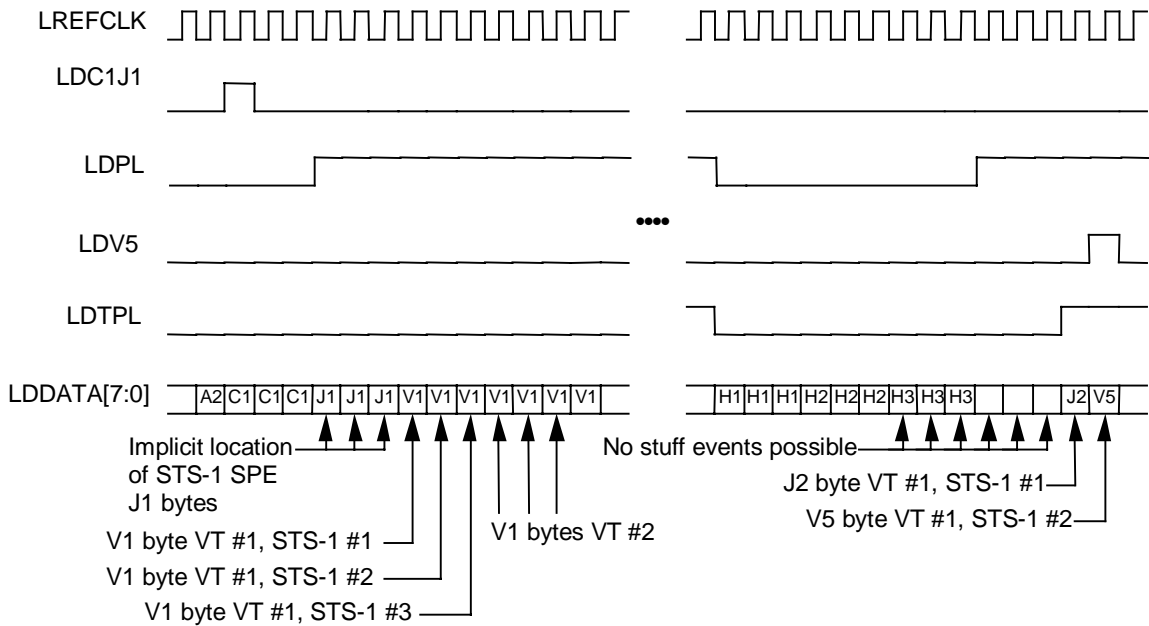
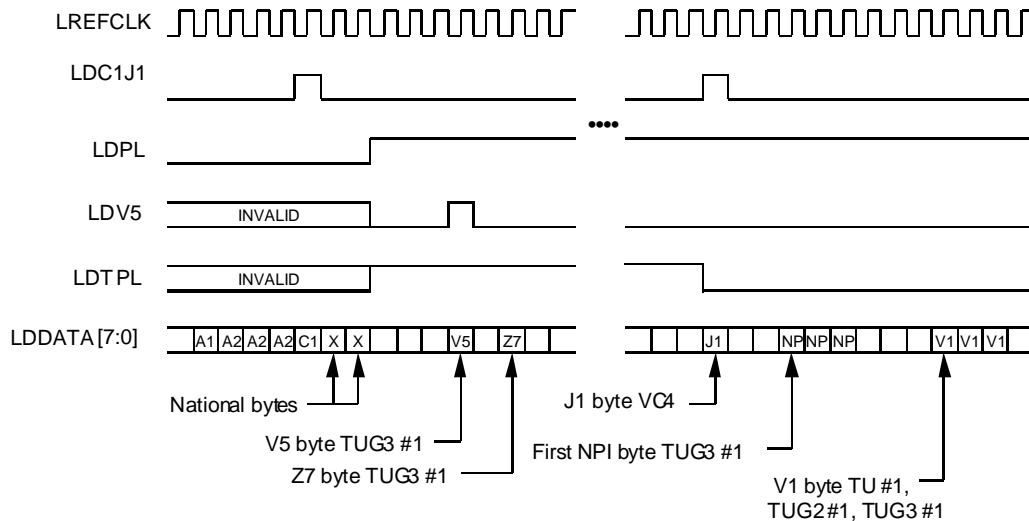


Figure 47 shows the function of the various telecom DROP bus signals in AU4 mode. Data on LDDATA [7:0] is sampled on the rising edge of LREFCLK. The bytes forming the VC4 virtual container are identified by the setting the LDPL signal high. The LDC1J1V1 signal pulses high, while LDPL is set low, to mark the single C1 byte in every frame of the AU4 transport envelope. The LDC1J1V1 signal is set high again with LDPL high to mark the J1 byte of the VC4. The bytes forming the various tributary synchronous payload envelopes are identified by the LDTPL signal being set high. The LDV5 signal pulses high to mark the V5 bytes of each outgoing tributaries.

**Figure 47: Telecom DROP Bus Timing - AU4 VC**


The LDV5 and LDTPL signals are optional when using the ingress VTPP within the TEMAP which will regenerate the LDV5 and LDTPL signals from LDC1J1V1, LDPL and the pointers within LDDATA[7:0]. In order to bypass the ingress VTPP, the position of the single J1 byte and the VC4 is implicitly defined by the C1 byte position. In the locked AU4 mode, the VC4 is defined to be aligned to the AU4 transport envelope such that the J1 byte occupies the first available payload byte after the C1 byte, and no pointer justifications are possible.

### 13.4 Telecom ADD Bus Interface Timing

Figure 48 shows the function of the telecom ADD bus signals in AU3 mode. Data on LADATA[7:0] is updated on the rising edge of LREFCLK. The LAC1 input is sampled on the rising edge of LREFCLK and aligns all devices on the ADD bus by marking the first C1 byte of the first STS-1 in every fourth STS-3 transport envelope. LAC1 pulses every fourth STS-3 to indicate tributary multiframe alignment on the ADD bus. The bytes forming the three STS-1 synchronous payload envelopes are identified when the LAPL signal is high. The LAC1J1V1 signal pulses high, while LAPL is set low, to mark the C1 byte of the first STS-1 in every frame of the STS-3 transport envelope. The LAC1J1V1 signal is high when the LAPL signal is high to mark every J1 byte of each of the three STS-1 SPEs. The three STS-1 SPEs are fixed at two different alignments to the STS-3 transport envelope. The first is shown in Figure 48 in which the J1 bytes follow immediately after the C1 bytes. The second alignment is at SPE pointer location zero where the J1 bytes follow immediately after the H3 bytes.

The LAC1 signal is updated on the rising edge of LREFCLK. It is output during when the TEMAP is outputting valid tributary data onto the ADD bus. It is asserted high for all bytes making up a tributary and is asserted low during overhead bytes.

**Figure 48: Output Bus Timing - Locked STS-1 SPEs / AU3 VCs**

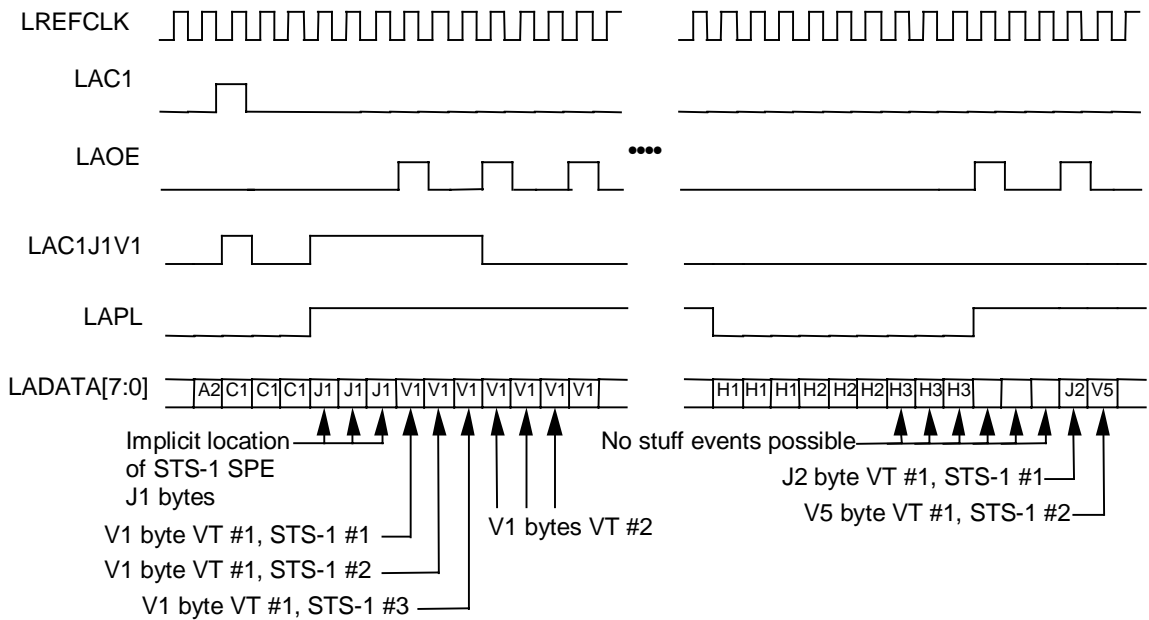
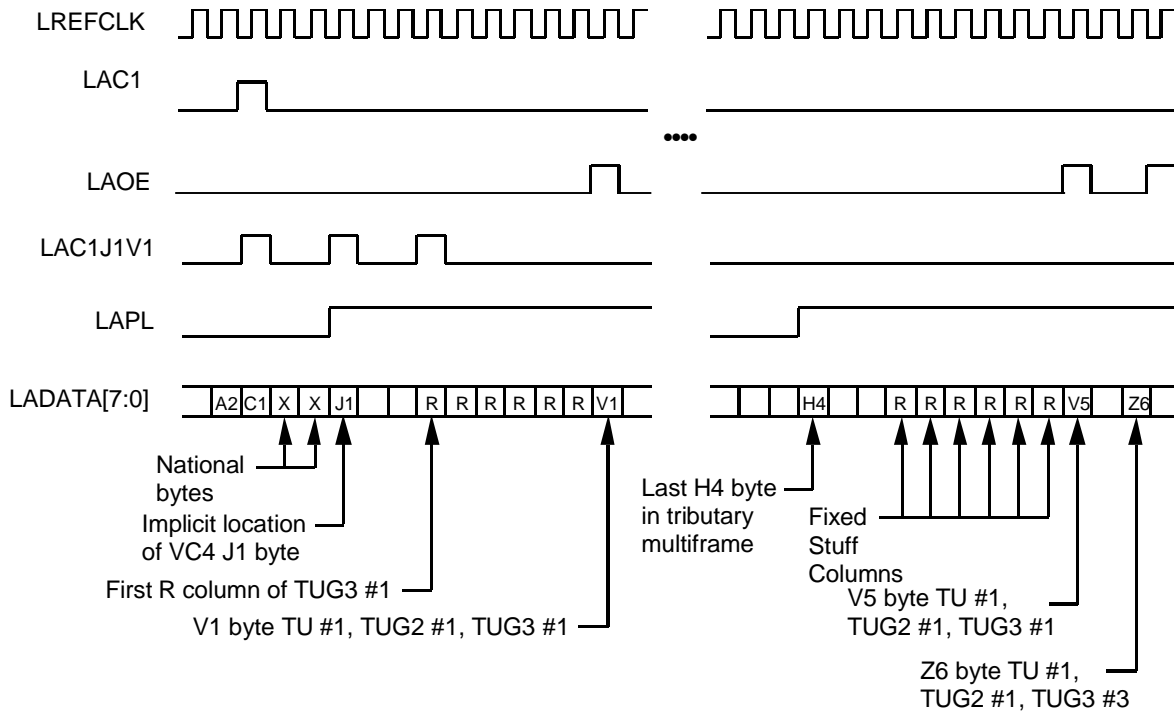


Figure 49 shows the function of the TEMAP telecom ADD bus when operating in AU4 mode. In AU4 mode, the position of the single J1 byte and the VC4 is implicitly defined by the LAC1 byte position. The VC4 is defined to be aligned to the AU4 transport envelope such that the J1 byte occupies the first available payload byte after the C1 byte. No pointer justification events take place on the ADD bus. LAC1J1V1 pulses high to mark the first C1 byte, the J1 byte and the third byte after J1 of the first tributary in the AU4 stream. LAPL identifies the payload bytes on LADATAD[7:0].

**Figure 49 - Output Bus Timing - Locked AU4 VC Case**

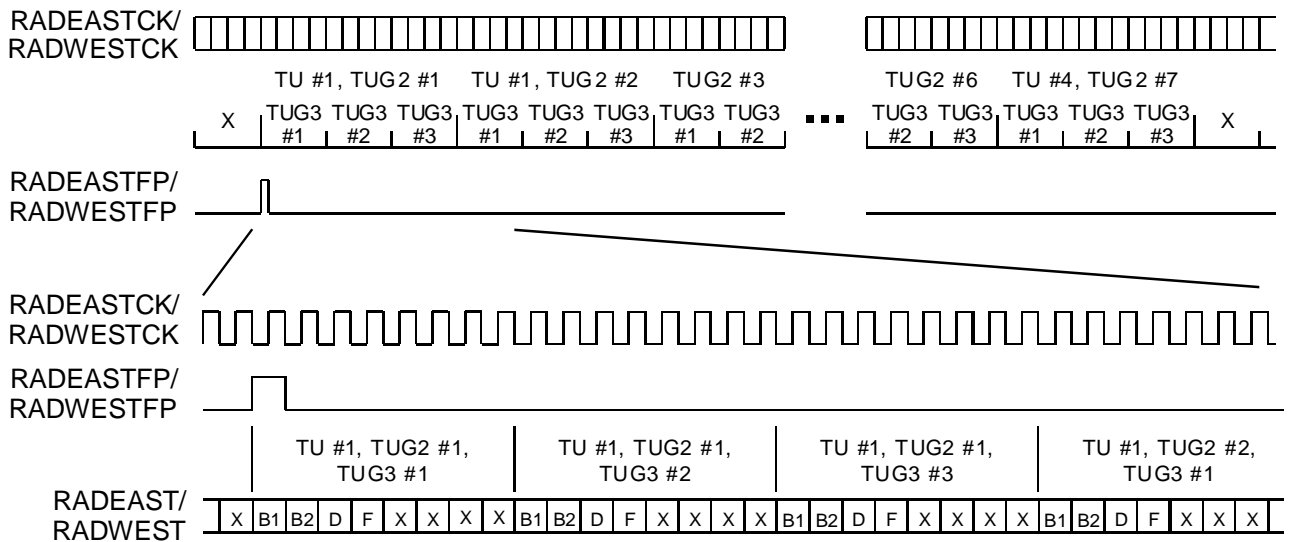


**13.5 SONET/SDH Serial Alarm Port Timing**

The timing relationships of the signals related to the remote serial alarm port are shown in Figure 50. The remote serial alarm port clocks, RADEASTCK and RADWESTCK, are nominally 9.72 MHz clocks but can range from 1.344 MHz to 10 MHz. The remote serial alarm port frame pulses, RADEASTFP and RADWESTFP, mark the first BIP-2 error bit (B1 in Figure 50) of the first tributary (TU #1 of TUG2 #1, TUG3 #1) on RADEAST and RADWEST, respectively. The frame pulses must be set high to mark every first BIP-2 error bit of the first tributary. Tributaries on RADEAST and RADWEST are arranged in the order of transmission of an STM-1 stream as defined in the references. I.e., TU #1 of TUG2 #1 in TUG3 #1, TU#1 of TUG2 #1 in TUG3 #2, TU#1 of TUG2 #1 in TUG3 #3, TU#1 of TUG2 #2 in TUG3 #1, ... TU #1 of TUG2 #7 in TUG3 #3, TU #2 of TUG2 #1 in TUG3 #1, ... TU #2 of TUG2 #7 in TUG3 #3, TU #3 of TUG2 #1 in TUG3 #1, ... TU #4 of TUG2 #7 in TUG3 #3. Timeslot assignment on RADEAST and RADWEST is unrelated to the configuration of the TUG2. Timeslots are always reserved for four tributaries in every TUG2 even if it is configured for tributaries with higher bandwidth than TU11, such as TU12. At timeslots devoted to non-existent tributaries, for example, tributary 4 of a TUG2 configured for TU12, RADEAST and RADWEST will be ignored.

Each tributary in the remote serial alarm port is allocated eight timeslots. The first two timeslots, labeled B1 and B2 in Figure 50, reports the two possible BIP-2 errors in the tributary payload frame. An alarm contributing to remote defect indications is reported in the third timeslot and is labeled D in Figure 50. The timeslot labeled F report alarms contributing to remote failure indications. In extended RDI mode, the D and F bits are considered as two bit codepoint and will be reported on the RDI and RFI signals. Out of extended RDI mode, the D and F bits are independent. The remaining four timeslots are unused and are ignored.

**Figure 50: Remote Serial Alarm Port Timing**



**13.6 SBI DROP Bus Interface Timing**

**Figure 51: SBI DROP Bus T1/E1 Functional Timing**

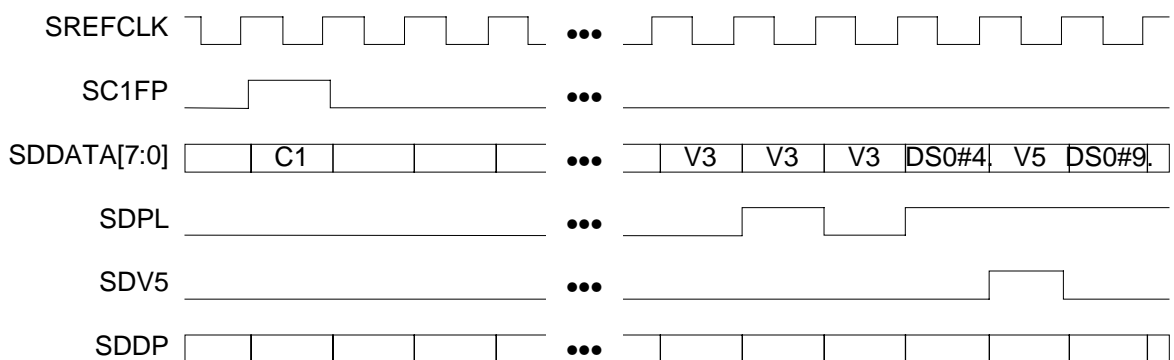


Figure 51 illustrates the operation of the SBI DROP Bus, using a negative justification on the second to last V3 octet as an example. The justification is indicated by asserting SDPL high during the V3 octet. The timing diagram also shows the location of one of the tributaries by asserting SDV5 high during the V5 octet.

### Figure 52: SBI DROP Bus DS3 Functional Timing

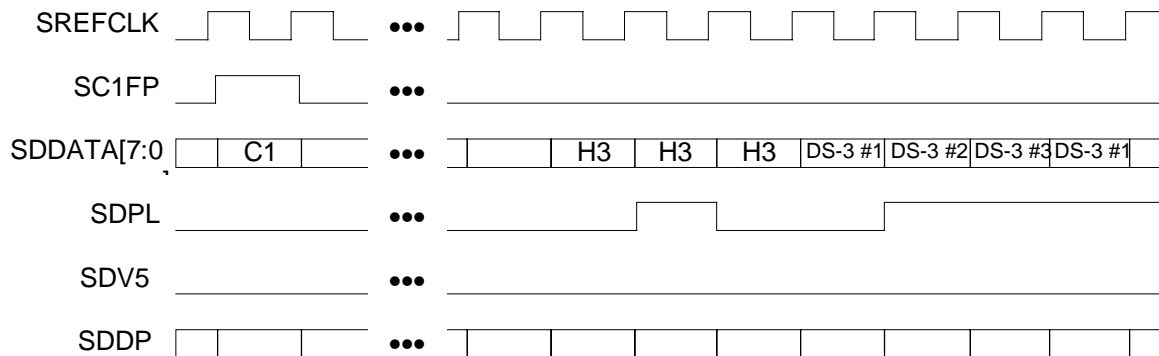


Figure 52 shows three DS-3 tributaries mapped onto the SBI bus. A negative justification is shown for DS-3 #2 during the H3 octet with SDPL asserted high. A positive justification is shown for DS-3#1 during the first DS-3#1 octet after H3 which has SDPL asserted low.

### 13.7 SBI ADD Bus Interface Timing

The SBI ADD bus functional timing for the transfer of tributaries whether T1/E1 or DS3 is the same as for the SBI DROP bus. The only difference is that the SBI ADD bus has a few additional signals. The SAJUST\_REQ signal is used to by the TEMAP in SBI master timing mode to provide transmit timing to SBI link layer devices. The SBIACT signal is asserted whenever the TEMAP is driving the SBI ADD bus and is used with the SBIDET[1:0] signals of other TEMAPs to detect and protect against SBI ADD bus conflicts.

**Figure 53: SBI ADD Bus Adjustment Request Functional Timing**

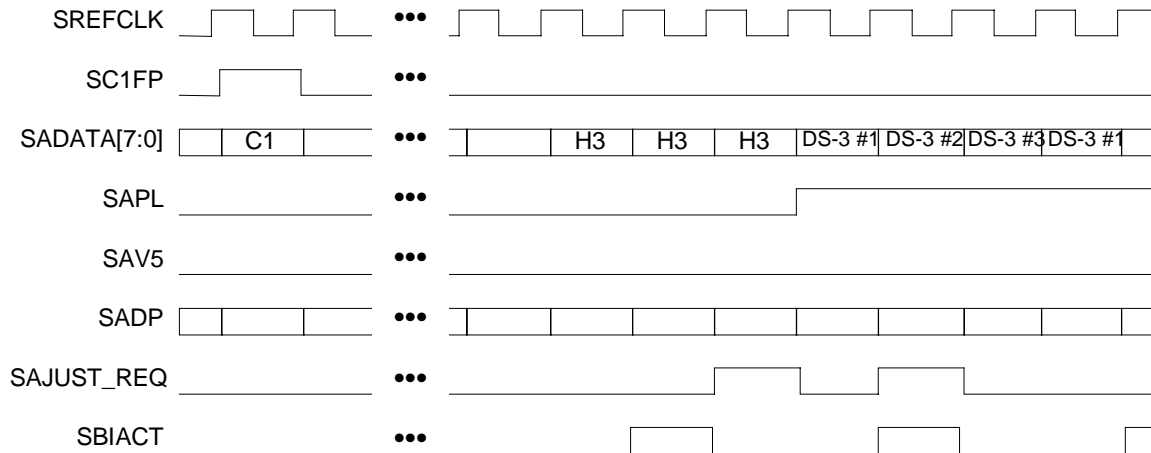
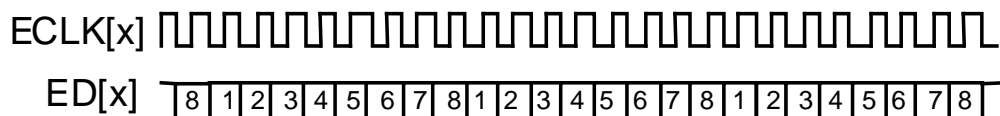


Figure 53 illustrates the operation of the SBI ADD Bus, using positive and negative justification requests as an example. (The responses to the justification requests would take effect during the next multi-frame.) The negative justification request occurs on the DS-3#3 tributary when SAJUST\_REQ is asserted high during the H3 octet. The positive justification occurs on the DS-3#2 tributary when SAJUST\_REQ is asserted high during the first DS-3#2 octet after the H3 octet. The SBIACT signal is shown for the case in which TEMAP is driving DS-3#2 onto the SBI ADD bus.

**13.8 Egress Serial Clock and Data Interface Timing**

By convention in the following functional timing diagrams, the first bit transmitted in each channel shall be designated bit 1 and the last shall be designated bit 8. Each of the Ingress and Egress Master and Clock Modes apply to both T1 and E1 configurations.

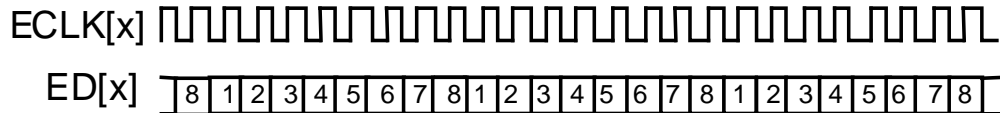
**Figure 54: T1 and E1 Egress Interface Clock Master: Clear Channel Mode**



The Egress Interface is configured for the Clock Master: Clear Channel mode by writing to EMODE[2:0] in the T1/E1 Egress Serial Interface Mode Select register. ED[x] is sampled on the rising edge of the ECLK[x] output. When the the EDE bit in the T1/E1 Serial Interface Configuration register is set to logic 1, then ED[x] is

sampled on the falling edge of ECLK[x], and the functional timing is described by Figure 54 with the ECLK[x] signal inverted.

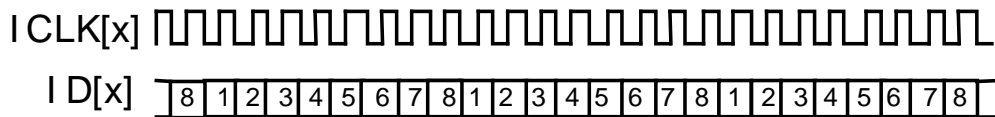
**Figure 55: T1 and E1 Egress Interface Clock Slave: Clear Channel Mode**



The Egress Interface is configured for the Clock Slave: Clear Channel mode by writing to EMODE[2:0] in the T1/E1 Egress Serial Interface Mode Select register. ED[x] is clocked in on the rising edge of the ECLK[x] input. When the EDE bit in the T1/E1 Serial Interface Configuration register is set to logic 1, then ED[x] is sampled on the falling edge of ECLK[x], and the functional timing is described by Figure 55 with the ECLK[x] signal inverted.

### 13.9 Ingress Serial Clock and Data Interface Timing

**Figure 56: T1 and E1 Ingress Interface Clock Master: Clear Channel Mode**



The Ingress Interface is configured for the Clock Slave: Clear Channel mode by writing to IMODE[1:0] in the T1/E1 Ingress Serial Interface Mode Select register. ID[x] is updated on the falling edge of the ICLK[x] input. When the IDE bit in the T1/E1 Serial Interface Configuration register is set to logic 1, then ID[x] is updated on the rising edge of ICLK[x], and the functional timing is described by Figure 56 with the ICLK[x] signal inverted.

## 14 ABSOLUTE MAXIMUM RATINGS

Maximum ratings are the worst case limits that the device can withstand without sustaining permanent damage. They are not indicative of normal mode operation conditions.

**Table 32 - Absolute Maximum Ratings**

Parameter	Symbol	Value	Units
Case Temperature under Bias		-40 to +85	°C
Storage Temperature	T <sub>ST</sub>	-40 to +125	°C
Supply Voltage	V <sub>DD2.5</sub>	-0.3 to + 3.5	V <sub>DC</sub>
Supply Voltage	V <sub>DD3.3</sub>	-0.3 to + 4.6	V <sub>DC</sub>
Supply Voltage	V <sub>DDQ</sub>	-0.3 to + 4.6	V <sub>DC</sub>
Voltage on Any Pin (note 3)	V <sub>IN</sub>	-0.3 to + 5.5	V <sub>DC</sub>
Static Discharge Voltage		±1000	V
Latch-Up Current		±100	mA
DC Input Current	I <sub>IN</sub>	±20	mA
Lead Temperature		+230	°C
Junction Temperature	T <sub>J</sub>	+150	°C

### Notes on Power Supplies:

1. VDD3.3 and VDDQ should power up before VDD2.5.
2. VDD3.3 and VDDQ should not be allowed to drop below the VDD2.5 voltage level except when VDD2.5 is not powered.
3. All pins on the TEMUX are 5V tolerant.

## 15 D.C. CHARACTERISTICS

$T_C = -40^{\circ}\text{C}$  to  $+85^{\circ}\text{C}$ ,  $V_{DD3.3} = 3.3\text{V} \pm 10\%$ ,  $V_{DD2.5} = 2.5\text{V} \pm 8\%$   
 (Typical Conditions:  $T_C = 25^{\circ}\text{C}$ ,  $V_{DD3.3} = 3.3\text{V}$ ,  $V_{DD2.5} = 2.5\text{V}$ )

**Table 33 - D.C. Characteristics**

Symbol	Parameter	Min	Typ	Max	Units	Conditions
VDD3.3	Power Supply	2.97	3.3	3.63	Volts	
VDDQ	Power Supply	2.97	3.3	3.63	Volts	
VDD2.5	Power Supply	2.3	2.5	2.7	Volts	
VIL	Input Low Voltage	0		0.8	Volts	Guaranteed Input LOW Voltage
VIH	Input High Voltage	2.0			Volts	Guaranteed Input HIGH Voltage
VOL	Output or Bidirectional Low Voltage	0	0.1	0.4	Volts	VDD = min, IOL = -4mA for D[7:0], LAOE, RECVCLK1, RECVCLK2, TCLK, TPOS/TDAT, TNEG/TMFP, RGAPCLK/RSCLK, RDATAO, RFPO/RMFPO, ROVRHD, TFPO/TMFPO/TGAPCLK, SBIACT, IOL = -8mA for SDDATA[7:0], SDDP, SDPL, SDV5, SAJUST_REQ, SC1FP, LAC1J1V1, LADATA[7:0], LADP, LAPL, IOL = -2mA for others. Note 3
VOH	Output or Bidirectional High Voltage	2.4		VDD3.3	Volts	VDD = min, IOH = -4mA for D[7:0], LAOE, RECVCLK1, RECVCLK2, TCLK, TPOS/TDAT, TNEG/TMFP, RGAPCLK/RSCLK, RDATAO, RFPO/RMFPO, ROVRHD, TFPO/TMFPO/TGAPCLK, SBIACT, IOH = -8mA for SDDATA[7:0], SDDP, SDPL, SDV5, SAJUST_REQ, SC1FP, LAC1J1V1, LADATA[7:0], LADP, LAPL, IOH = -2mA for others. Note 3

Symbol	Parameter	Min	Typ	Max	Units	Conditions
VT+	Reset Input High Voltage	2.0			Volts	TTL Schmidt
VT-	Reset Input Low Voltage			0.8	Volts	
VTH	Reset Input Hysteresis Voltage		TBD		Volts	
IILPU	Input Low Current	+20		+100	μA	VIL = GND. Notes 1, 3
IIHPU	Input High Current	-10		+10	μA	VIH = VDD. Notes 1, 3
IIL	Input Low Current	-10		+10	μA	VIL = GND. Notes 2, 3
IIH	Input High Current	-10		+10	μA	VIH = VDD. Notes 2, 3
CIN	Input Capacitance		5		pF	Excluding Package, Package Typically 2 pF
COUT	Output Capacitance		5		pF	Excluding Package, Package Typically 2 pF
CIO	Bidirectional Capacitance		5		pF	Excluding Package, Package Typically 2 pF
IDDOP1	Operating Current		368		mA	VDD2.5 = 2.7V VDD3.3 = 3.63 V Outputs Unloaded, Telecom to SBI mode (Note 4)
			4		mA	
IDDOP2	Operating Current		225		mA	VDD2.5 = 2.7V VDD3.3 = 3.63 V Outputs Unloaded, DS3 to serial clock and data mode (Note 4)
			5		mA	

### Notes on D.C. Characteristics:

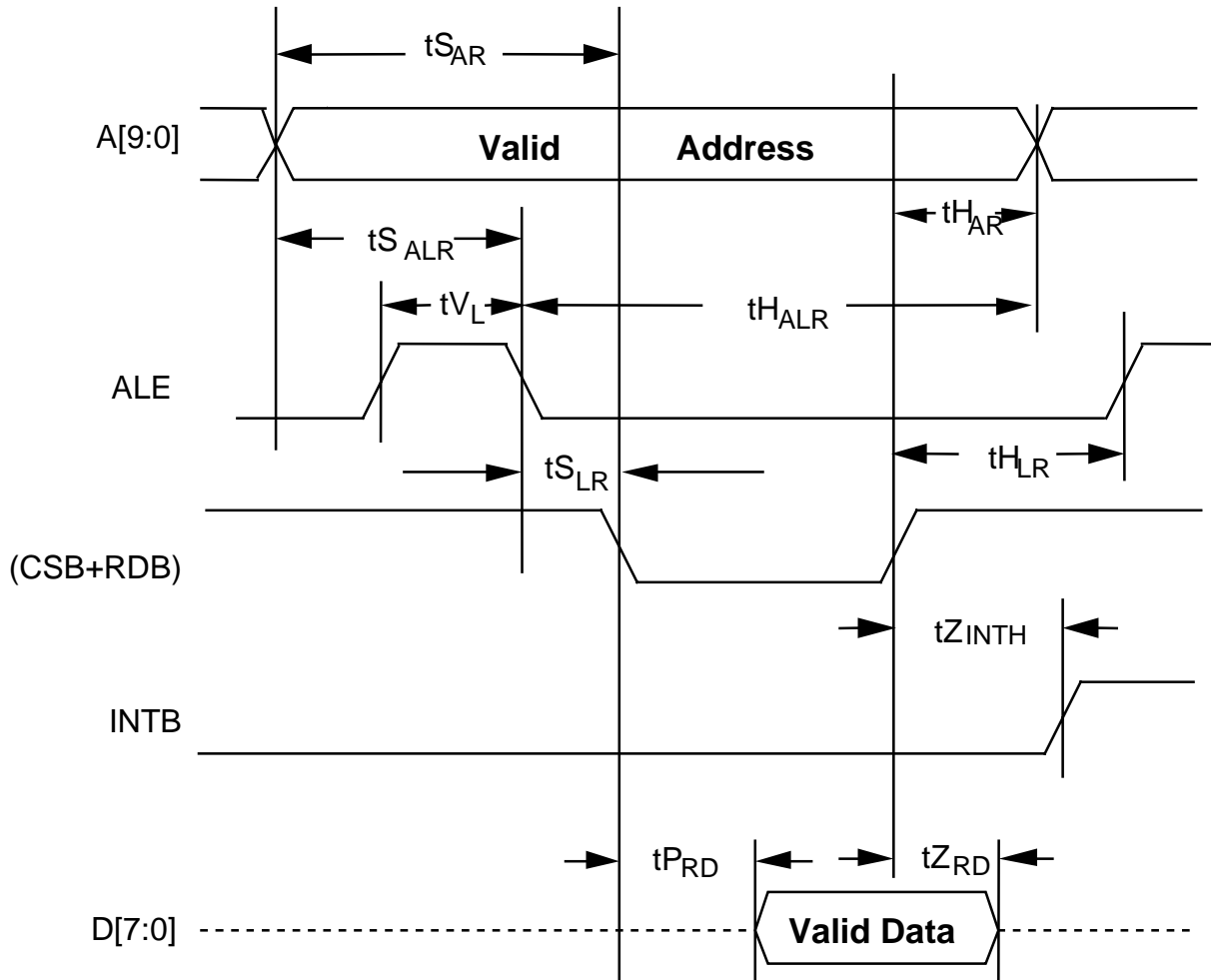
1. Input pin or bi-directional pin with internal pull-up resistor.
2. Input pin or bi-directional pin without internal pull-up resistor
3. Negative currents flow into the device (sinking), positive currents flow out of the device (sourcing).
4. Typical values are only given as a design aid and are subject to change once TEMAP is fully characterized.

## **16 MICROPROCESSOR INTERFACE TIMING CHARACTERISTICS**

(TC = -40°C to +85°C, V<sub>DD3.3</sub> = 3.3V ±10%, V<sub>DD2.5</sub> = 2.5V ±8%)

**Table 34: Microprocessor Interface Read Access**

<b>Symbol</b>	<b>Parameter</b>	<b>Min</b>	<b>Max</b>	<b>Units</b>
tSAR	Address to Valid Read Set-up Time	10		ns
tHAR	Address to Valid Read Hold Time	5		ns
tSALR	Address to Latch Set-up Time	10		ns
tHALR	Address to Latch Hold Time	10		ns
tVL	Valid Latch Pulse Width	20		ns
tSLR	Latch to Read Set-up	0		ns
tHLR	Latch to Read Hold	5		ns
tPRD	Valid Read to Valid Data Propagation Delay		70	ns
tZRD	Valid Read Negated to Output Tri-state		20	ns
tZINTH	Valid Read Negated to Output Tri-state		50	ns

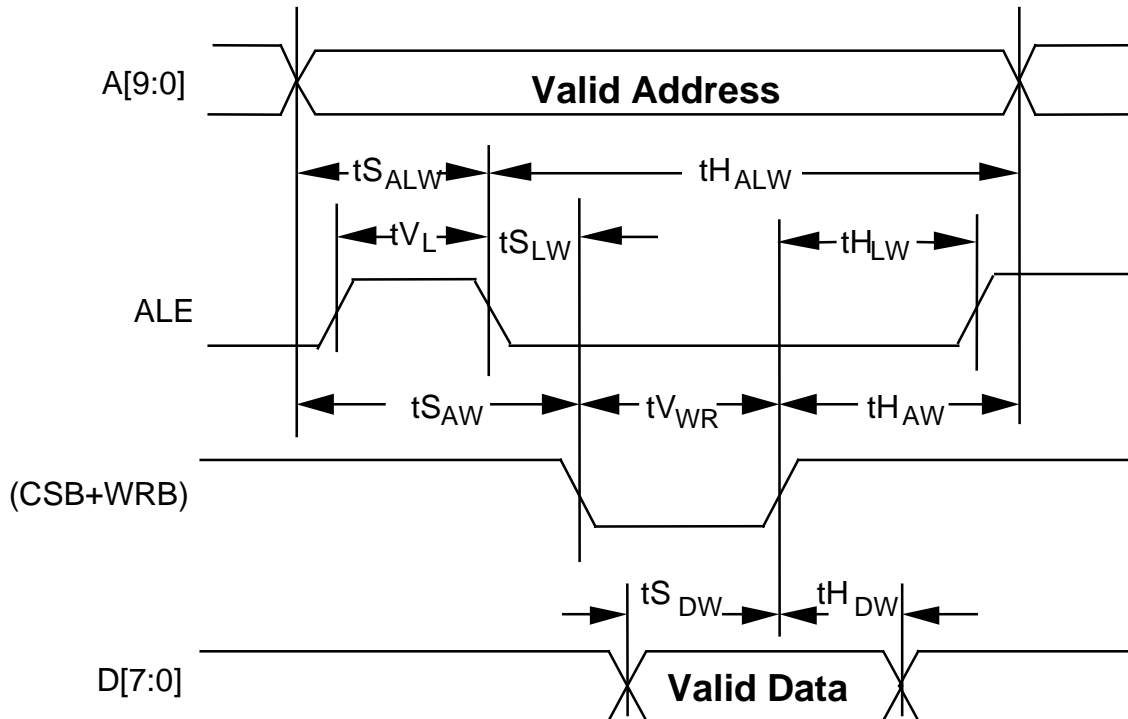
**Figure 42: Microprocessor Interface Read Timing**

**Notes on Microprocessor Interface Read Timing:**

1. Output propagation delay time is the time in nanoseconds from the 1.4 Volt point of the reference signal to the 1.4 Volt point of the output.
2. Maximum output propagation delays are measured with a 100 pF load on the Microprocessor Interface data bus, (D[7:0]).
3. A valid read cycle is defined as a logical OR of the CSB and the RDB signals.
4. In non-multiplexed address/data bus architectures, ALE should be held high so parameters  $t_{SALR}$ ,  $t_{H_AR}$ ,  $t_{V_L}$ , and  $t_{SLR}$  are not applicable.

5. Parameter tHAR is not applicable if address latching is used.
6. When a set-up time is specified between an input and a clock, the set-up time is the time in nanoseconds from the 1.4 Volt point of the input to the 1.4 Volt point of the clock.
7. When a hold time is specified between an input and a clock, the hold time is the time in nanoseconds from the 1.4 Volt point of the input to the 1.4 Volt point of the clock.

**Table 35: Microprocessor Interface Write Access**

<b>Symbol</b>	<b>Parameter</b>	<b>Min</b>	<b>Max</b>	<b>Units</b>
tSAW	Address to Valid Write Set-up Time	10		ns
tSDW	Data to Valid Write Set-up Time	20		ns
tSALW	Address to Latch Set-up Time	10		ns
tHALW	Address to Latch Hold Time	10		ns
tVL	Valid Latch Pulse Width	20		ns
tSLW	Latch to Write Set-up	0		ns
tHLW	Latch to Write Hold	5		ns
tHDW	Data to Valid Write Hold Time	5		ns
tHAW	Address to Valid Write Hold Time	5		ns
TVWR	Valid Write Pulse Width	40		ns

**Figure 43: Microprocessor Interface Write Timing**

**Notes on Microprocessor Interface Write Timing:**

1. A valid write cycle is defined as a logical OR of the CSB and the WRB signals.
2. In non-multiplexed address/data bus architectures, ALE should be held high so parameters  $t_{S_{ALW}}$ ,  $t_{H_{ALW}}$ ,  $t_{V_L}$ ,  $t_{S_{LW}}$  and  $t_{H_{LW}}$  are not applicable.
3. Parameter  $t_{H_{AW}}$  is not applicable if address latching is used.
4. When a set-up time is specified between an input and a clock, the set-up time is the time in nanoseconds from the 1.4 Volt point of the input to the 1.4 Volt point of the clock.
5. When a hold time is specified between an input and a clock, the hold time is the time in nanoseconds from the 1.4 Volt point of the input to the 1.4 Volt point of the clock.

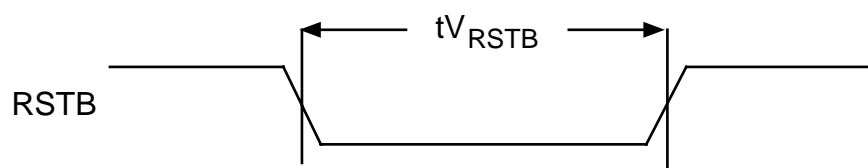
## 17 TEMAP TIMING CHARACTERISTICS

(TC = -40°C to +85°C  $V_{DD3.3} = 3.3V \pm 10\%$ ,  $V_{DD2.5} = 2.5V \pm 8\%$ )

**Table 36: RSTB Timing**

Symbol	Description	Min	Max	Units
tVRSTB	RSTB Pulse Width	100		ns

**Figure 44: RSTB Timing**



**Table 37: DS3 Transmit Interface Timing**

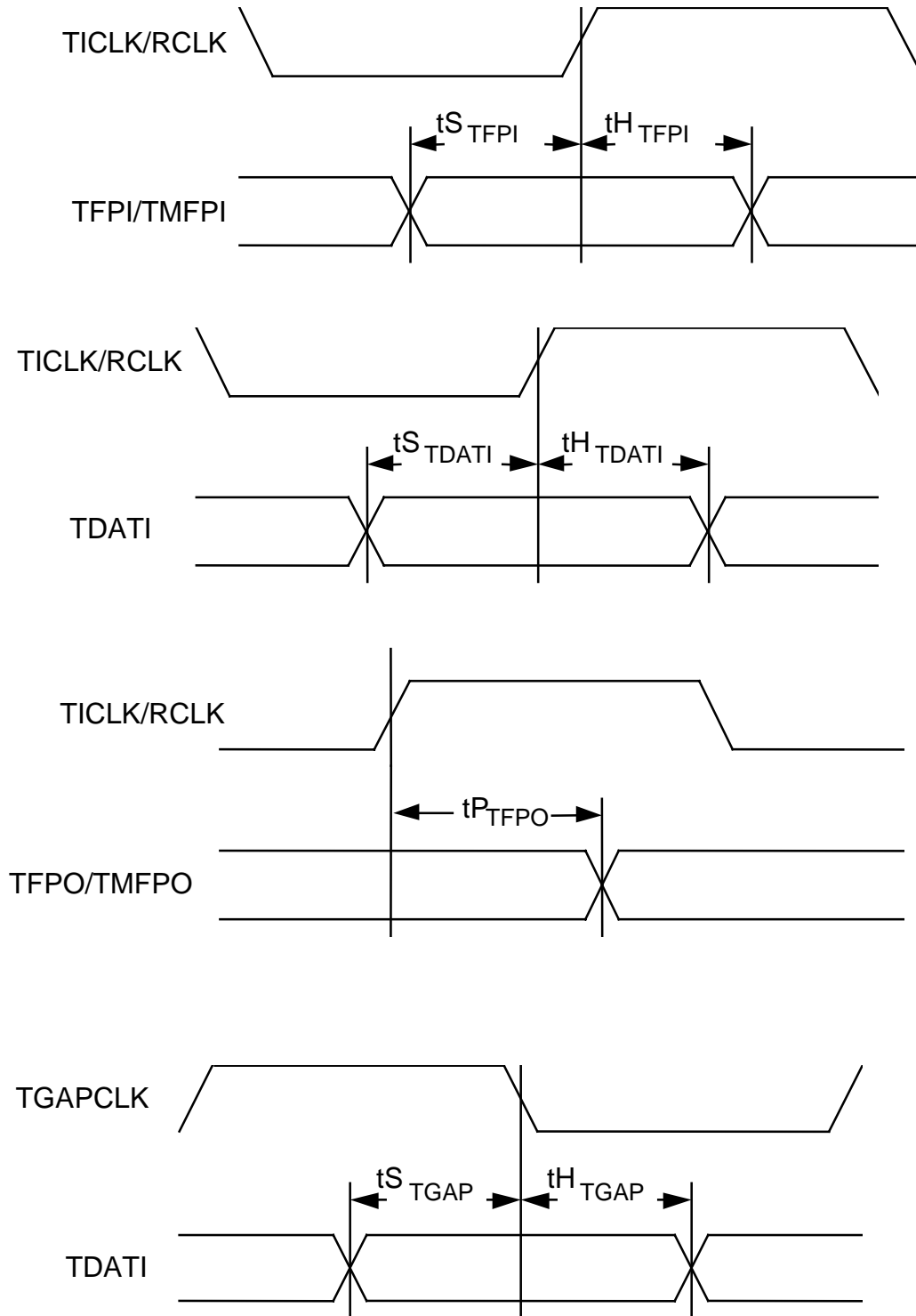
Symbol	Description	Min	Max	Units
f <sub>TICKL</sub>	TICKL Frequency		52	MHz
t <sub>0TICKL</sub>	TICKL minimum pulse width low	7.7		ns
t <sub>1TICKL</sub>	TICKL minimum pulse width high	7.7		ns
T <sub>STFPI</sub> (note 1)	TFPI/TMFPI to TICKL Set-up Time (LOOPT=0) TFPI/TMFPI to RCLK Set-up Time (LOOPT=1)	5 5		ns
T <sub>H<sub>TFPI</sub></sub> (note 2)	TFPI/TMFPI to TICKL Hold Time (LOOPT=0) TFPI/TMFPI to RCLK Hold Time (LOOPT=1)	1 1		ns
T <sub>SDATI</sub> (note 1)	TDATI to TICKL Set-up Time (LOOPT = 0) TDATI to RCLK Set-up Time (LOOPT = 1)	5 5		ns
T <sub>H<sub>TDATI</sub></sub> (note 2)	TDATI to TICKL Hold Time (LOOPT = 0) TDATI to RCLK Hold Time (LOOPT = 1)	1 1		ns
T <sub>STGAP</sub>	TDATI to TGAPCLK Set-up Time	3		ns

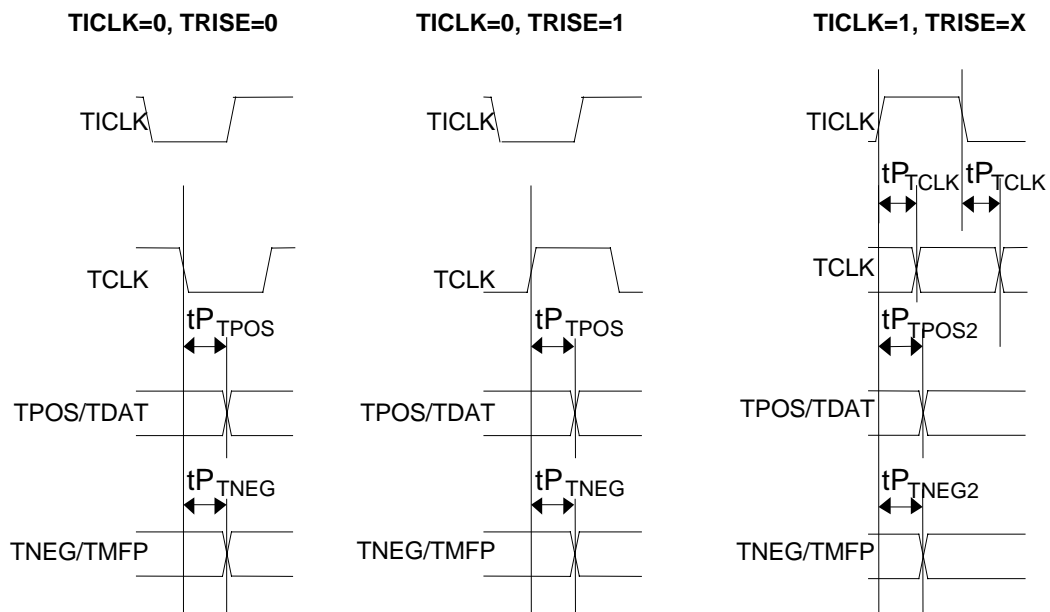
(note 1)				
TH <sub>TGAP</sub> (note 2)	TDATI to TGAPCLK Hold Time	2		ns
TP <sub>TCLK</sub> (notes 3 & 4)	TICLK Edge to TCLK Edge Prop Delay	2	13	ns
TP <sub>TPOS</sub> (notes 3 & 4)	TCLK Edge to TPOS/TDAT Prop Delay	-1	4	ns
TP <sub>TNEG</sub> (notes 3 & 4)	TCLK Edge to TNEG/TMFP Prop Delay	-1	4	ns
tP <sub>TPOS2</sub> (notes 3 & 4)	TICLK High to TPOS/TDAT Prop Delay	2	13	ns
tP <sub>TNEG2</sub> (notes 3 & 4)	TICLK High to TNEG/TMFP Prop Delay	2	13	ns

### Notes on DS3 Transmit Interface Timing:

1. When a set-up time is specified between an input and a clock, the set-up time is the time in nanoseconds from the 1.4 Volt point of the input to the 1.4 Volt point of the clock.
2. When a hold time is specified between an input and a clock, the hold time is the time in nanoseconds from the 1.4 Volt point of the clock to the 1.4 Volt point of the input.
3. Output propagation delay time is the time in nanoseconds from the 1.4 Volt point of the reference signal to the 1.4 Volt point of the output.
4. Maximum and minimum output propagation delays are measured with a 20 pF load on all the outputs.
5. Maximum and minimum output propagation delays are measured with a 50 pF load on all the outputs.

**Figure 57: DS3 Transmit Interface Timing**





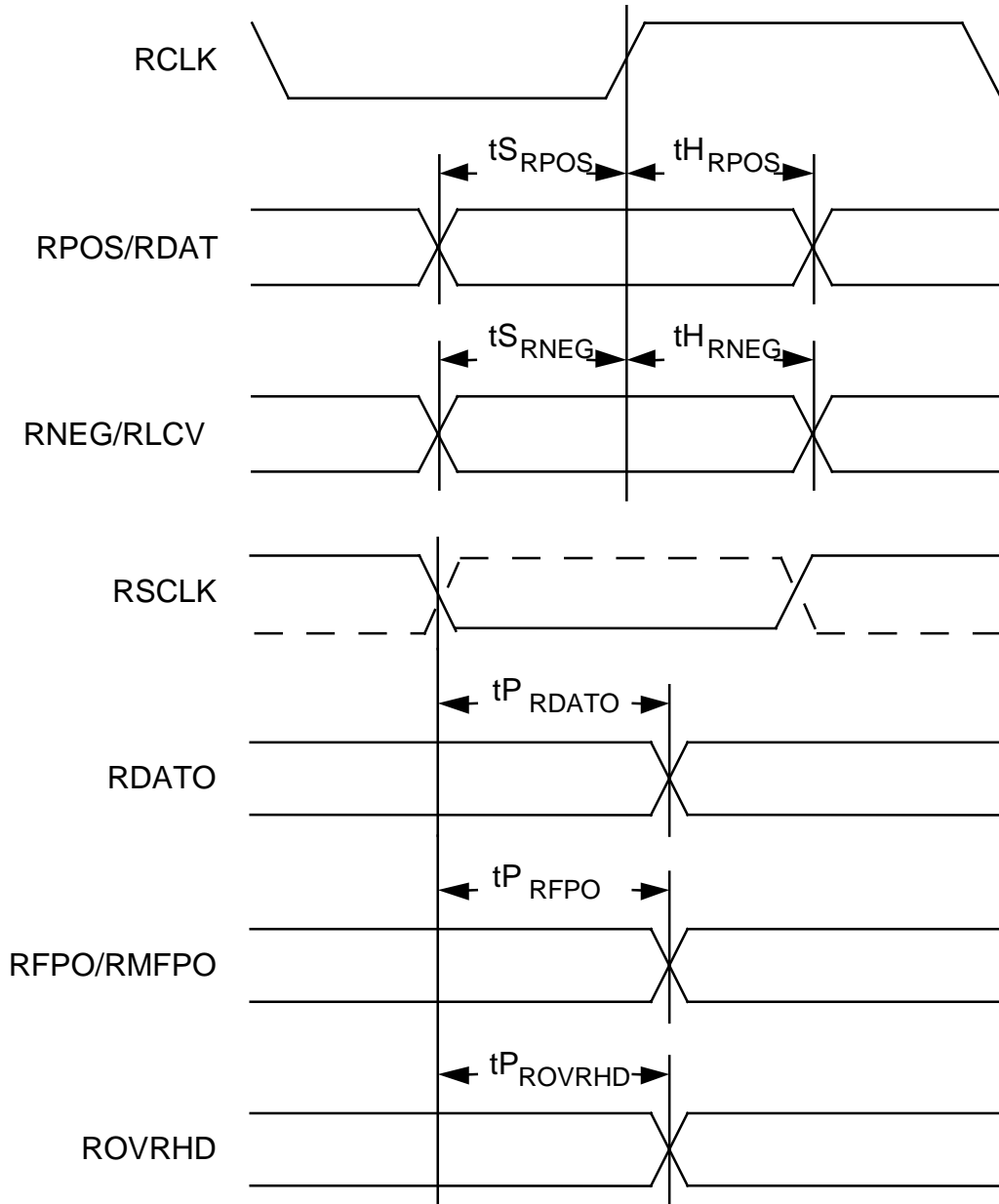
**Table 38: DS3 Receive Interface Timing**

Symbol	Description	Min	Max	Units
f <sub>RCLK</sub>	RCLK Frequency		52	MHz
t <sub>0RCLK</sub>	RCLK minimum pulse width low	7.7		ns
t <sub>1RCLK</sub>	RCLK minimum pulse width high	7.7		ns
t <sub>SRPOS</sub>	RPOS/RDAT Set-up Time (See Note 1)	4		ns
t <sub>HRPOS</sub>	RPOS/RDAT Hold Time (See Note 2)	1		ns
t <sub>SRNEG</sub>	RNEG/RLCV Set-Up Time (See Note 1)	4		ns
t <sub>HRNEG</sub>	RNEG/RLCV Hold Time (See Note 2)	1		ns
t <sub>PRDATO</sub>	RSCLK Edge to RDATO Prop Delay (See Notes 3 and 4)	2	10	ns
t <sub>PRFPO</sub>	RSCLK Edge to RFPO/RMFPO Prop Delay (See Notes 3 and 4)	2	10	ns
t <sub>PROVRHD</sub>	RSCLK Edge to ROVRHD Prop Delay (See Notes 3 and 4)	2	10	ns
t <sub>PRGAP</sub>	RGAPCLK Edge to RDATO[x] Prop Delay (See Notes 3 and 4)	2	10	ns

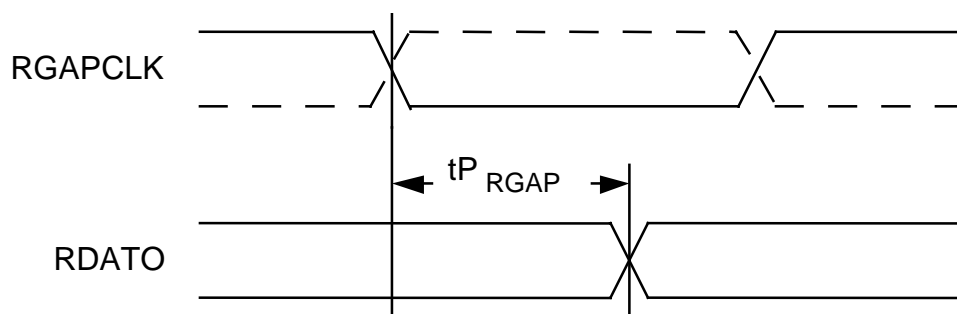
**Notes on DS3 Transmit Interface Timing:**

1. When a set-up time is specified between an input and a clock, the set-up time is the time in nanoseconds from the 1.4 Volt point of the input to the 1.4 Volt point of the clock.
2. When a hold time is specified between an input and a clock, the hold time is the time in nanoseconds from the 1.4 Volt point of the clock to the 1.4 Volt point of the input.
3. Output propagation delay time is the time in nanoseconds from the 1.4 Volt point of the reference signal to the 1.4 Volt point of the output.
4. Maximum and minimum output propagation delays are measured with a 50 pF load on all the outputs.

**Figure 58: DS3 Receive Interface Timing**



Dashed line RSCLK represents behaviour when RSCLKR register bit = 1.



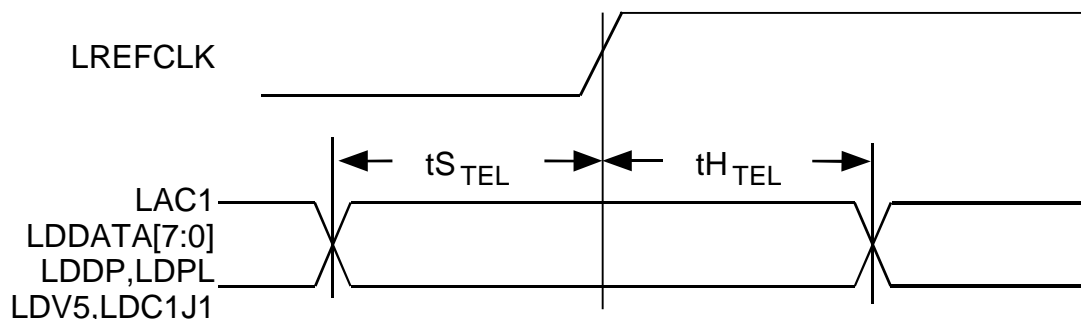
Dashed line RSCLK represents behaviour when RSCLKR register bit = 1.

**Table 39: Line Side Telecom BUS Input Timing (Figure 62)**

Symbol	Description	Min	Max	Units
	LREFCLK Frequency	19.44 -50 ppm	19.44 +50 ppm	MHz
	LREFCLK Duty Cycle	40	60	%
	CLK52M Frequency (51.84 MHz)	51.84 -50 ppm	51.84 +50 ppm	MHz
	CLK52M Frequency (44.928 MHz)	44.928 -50 ppm	44.928 +50 ppm	MHz
	CLK52M Duty Cycle	40	60	%
t <sub>STEL</sub>	All Telecom BUS Inputs Set-Up Time to LREFCLK (See Note 1)	5		ns
t <sub>HTEL</sub>	All Telecom BUS Inputs Hold Time to LREFCLK (See Note 2)	1		ns

**Notes on Telecom Input Timing:**

1. When a set-up time is specified between an input and a clock, the set-up time is the time in nanoseconds from the 1.4 Volt point of the input to the 1.4 Volt point of the clock.
2. When a hold time is specified between an input and a clock, the hold time is the time in nanoseconds from the 1.4 Volt point of the clock to the 1.4 Volt point of the input.

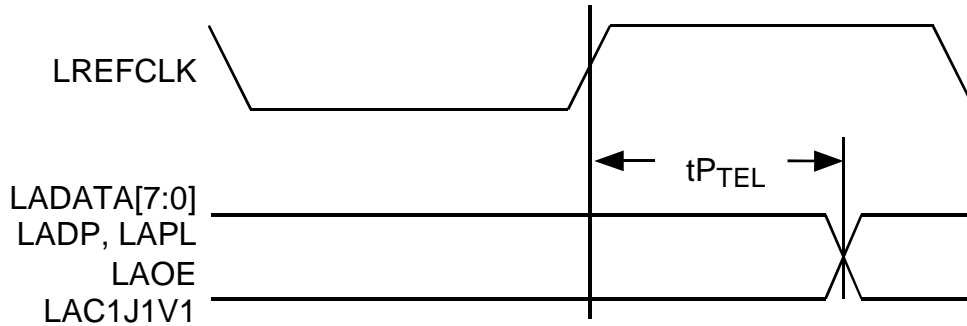
**Figure 59: Line Side Telecom BUS InputTiming****Table 40 – Telecom BUS Output Timing (Figure 63 to Figure 64)**

Symbol	Description	Min	Max	Units
$t_{P_{TEL}}$	LREFCLK to all Telecom BUS Outputs Valid (See Notes 1,2 and 4)	3	20	ns
$t_{Z_{TEL}}$	LREFCLK to all Telecom BUS tristateable Outputs going tristate (See Note 3)	3	20	ns
$t_{P_{TELOE}}$	LREFCLK to all Telecom BUS tristateable Outputs going valid from tristate (See Notes 1,2 and 4)	0	13	ns

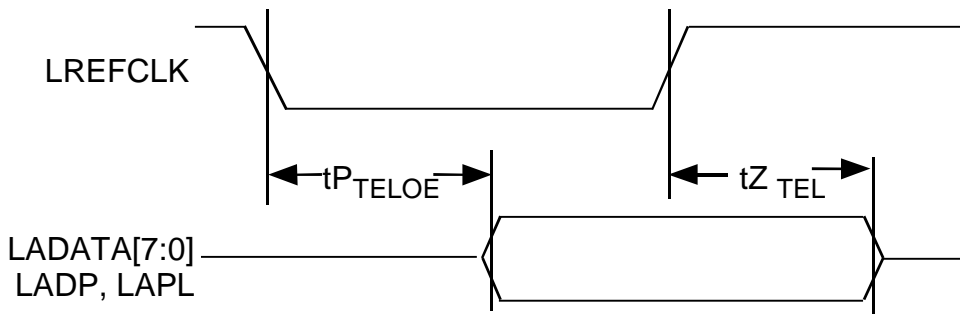
**Notes on Telecom Bus Output Timing:**

1. Output propagation delay time is the time in nanoseconds from the 1.4 Volt point of the reference signal to the 1.4 Volt point of the output.
2. Maximum and minimum output propagation delays are measured with a 100 pF load on all the outputs.
3. Output tristate delay is the time in nanoseconds from the 1.4 Volt point of the reference signal to the point where the total current delivered through the output is less than or equal to the leakage current.
4. The propagation delay,  $t_{P_{TEL}}$ , should be used when Telecom bus outputs are always driven as configured by LADDOE in register 1200H. The propagation delays,  $t_{P_{TELOE}}$  and  $t_{Z_{TEL}}$ , should be used when the Telecom bus outputs are multiplexed with other TEMAP devices using the tristate capability of the outputs as configured by LADDOE in register 1200H.

**Figure 60: Telecom BUS Output Timing**



**Figure 61: Telecom BUS Tristate Output Timing**

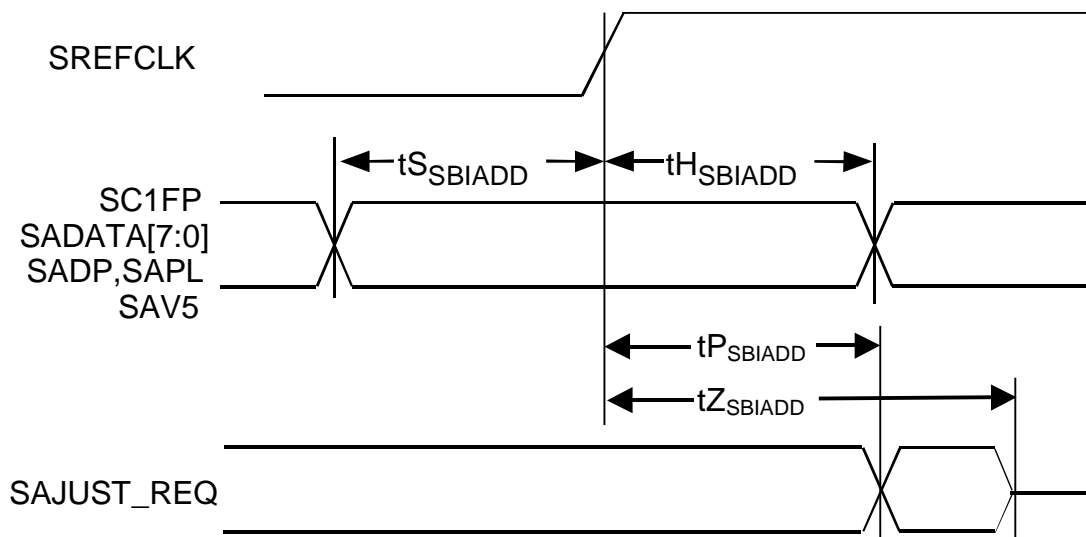


**Table 41: SBI ADD BUS Timing (Figure 62)**

Symbol	Description	Min	Max	Units
	SREFCLK Frequency	19.44 -50 ppm	19.44 +50 ppm	MHz
	SREFCLK Duty Cycle	40	60	%
t <sub>SBIADD</sub>	All SBI ADD BUS Inputs Set-Up Time to SREFCLK (See Note 1)	4		ns
t <sub>HSBIADD</sub>	All SBI ADD BUS Inputs Hold Time to SREFCLK (See Note 2)	0		ns
t <sub>PSBIADD</sub>	SREFCLK to SAJUST_REQ Valid (See Notes 3 and 4)	0	15	ns
t <sub>ZSBIADD</sub>	SREFCLK to SAJUST_REQ Tristate (See Note 5)	0	20	ns

**Notes on SBI Input Timing:**

1. When a set-up time is specified between an input and a clock, the set-up time is the time in nanoseconds from the 1.4 Volt point of the input to the 1.4 Volt point of the clock.
2. When a hold time is specified between an input and a clock, the hold time is the time in nanoseconds from the 1.4 Volt point of the clock to the 1.4 Volt point of the input.
3. Output propagation delay time is the time in nanoseconds from the 1.4 Volt point of the reference signal to the 1.4 Volt point of the output.
4. Maximum and minimum output propagation delays are measured with a 100 pF load on all the outputs.
5. Output tristate delay is the time in nanoseconds from the 1.4 Volt point of the reference signal to the point where the total current delivered through the output is less than or equal to the leakage current.

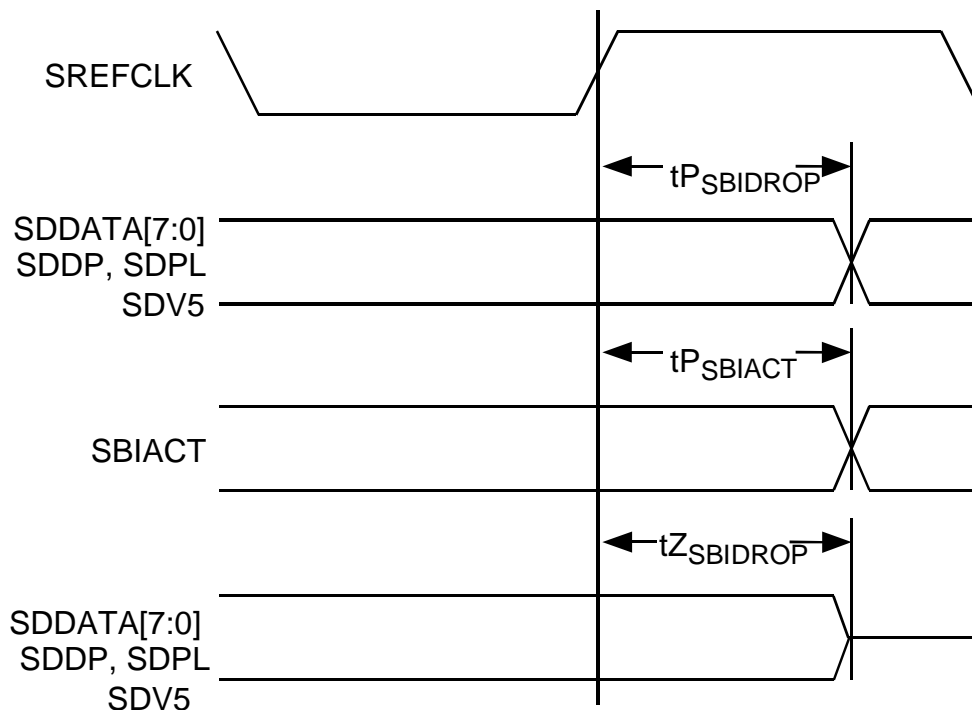
**Figure 62: SBI ADD BUS Timing****Table 42 – SBI DROP BUS Timing (Figure 63 to Figure 64)**

Symbol	Description	Min	Max	Units
$t_{P_{SBIDROP}}$	SREFCLK to SBI DROP BUS Outputs Valid (See Notes 1 and 2)	0	20	ns
$t_{P_{SBIACT}}$	SREFCLK to SBIACT Output Valid (See Notes 1 and 3)	0	15	ns
$t_{Z_{SBIDROP}}$	SREFCLK to All SBI DROP BUS Outputs Tristate (See Note 4)	0	20	ns
$T_{P_{OUTEN}}$	SBIDET[1] and SBIDET[0] low to All SBI DROP BUS Outputs Valid (See Notes 1 and 2)	0	12	ns
$t_{Z_{OUTEN}}$	SBIDET[1] and SBIDET[0] high to All SBI DROP BUS Outputs Tristate (See Note 4)	0	12	ns
$t_{S_{DET}}$	SBIDET[n] Set-Up Time to SREFCLK (See Notes 5)	4		ns
$t_{H_{DET}}$	SBIDET[n] Hold Time to SREFCLK (See Notes 6)	0		ns

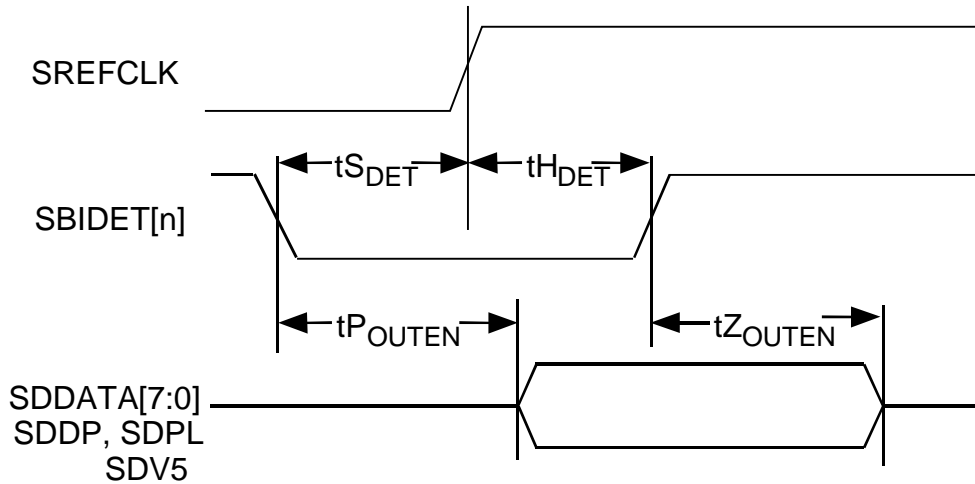
### Notes on SBI Output Timing:

1. Output propagation delay time is the time in nanoseconds from the 1.4 Volt point of the reference signal to the 1.4 Volt point of the output.
2. Maximum and minimum output propagation delays are measured with a 100 pF load on all the outputs.
3. Maximum and minimum output propagation delay is measured with a 50pF load.
4. Output tristate delay is the time in nanoseconds from the 1.4 Volt point of the reference signal to the point where the total current delivered through the output is less than or equal to the leakage current.
5. When a set-up time is specified between an input and a clock, the set-up time is the time in nanoseconds from the 1.4 Volt point of the input to the 1.4 Volt point of the clock.
6. When a hold time is specified between an input and a clock, the hold time is the time in nanoseconds from the 1.4 Volt point of the clock to the 1.4 Volt point of the input.

**Figure 63: SBI DROP BUS Timing**



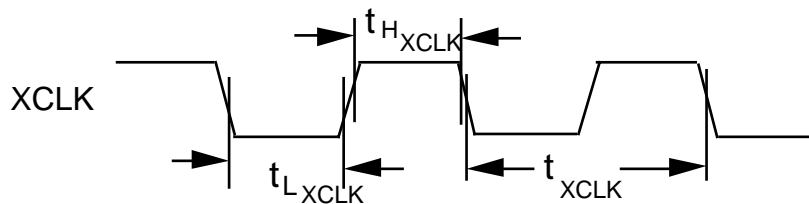
**Figure 64: SBI DROP BUS Collision Avoidance Timing**



**Table 43: XCLK Input (Figure 65)**

Symbol	Description	Min	Max	Units
$t_{LXCLK}$	XCLK Low Pulse Width <sup>4</sup>	8		ns
$t_{HXCLK}$	XCLK High Pulse Width <sup>4</sup>	8		ns
$t_{XCLK}$	XCLK Period (typically 1/37.056 MHz $\pm$ 32 ppm for T1 operation or 1/49.152 MHz for E1 operation) <sup>5</sup>	20		ns

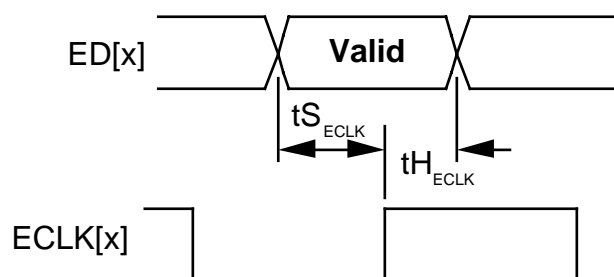
**Figure 65: XCLK Input Timing**



**Table 44: Egress Interface Input Timing - Clock Master : Clear Channel Mode (Figure 66)**

Symbol	Description	Min	Max	Units
tSECLK	ECLK[x] to ED[x] Set-up Time <sup>7,9</sup>	30		ns
tHECLK	ECLK[x] to ED[x] Hold Time <sup>8,9</sup>	30		ns

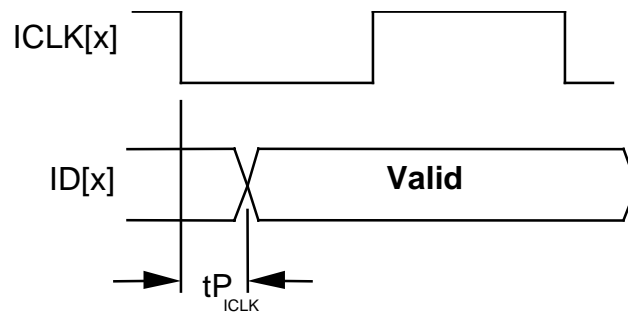
**Figure 66: Egress Interface Input Timing - Clock Master : Clear Channel Mode**



**Table 45: Ingress Interface Timing - Clock Master: Clear Channel Mode (Figure 67)**

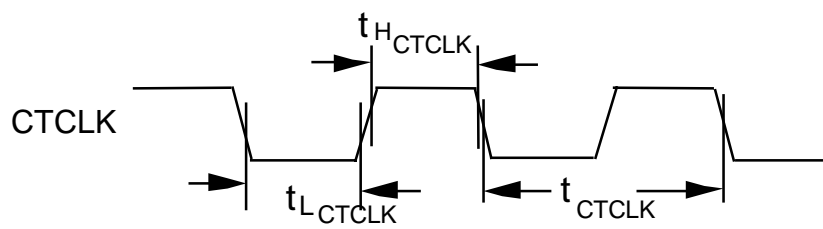
Symbol	Description	Min	Max	Units
tP <sub>ICLK</sub>	ICLK[x] to Ingress Output Prop. Delay <sup>9,10,11</sup>	-20	20	ns

**Figure 67: Ingress Interface Timing - Clock Master: Clear Channel Mode**



**Table 46: Transmit Line Interface Timing (Figure 68)**

Symbol	Description	Min	Max	Units
	CTCLK Frequency (when used for TJAT REF), typically 1.544 MHz $\pm$ 130 ppm for T1 operation or 2.048 MHz $\pm$ 50 ppm for E1 operation <sup>2,3,6</sup>	1.5	2.1	MHz
$t_{HCTCLK}$	CTCLK High Duration <sup>4</sup> (when used for TJAT REF)	100		ns
$t_{LCTCLK}$	CTCLK Low Duration <sup>4</sup> (when used for TJAT REF)	100		ns

**Figure 68: Transmit Line Interface Timing****Notes on Ingress and Egress Serial Interface Timing:**

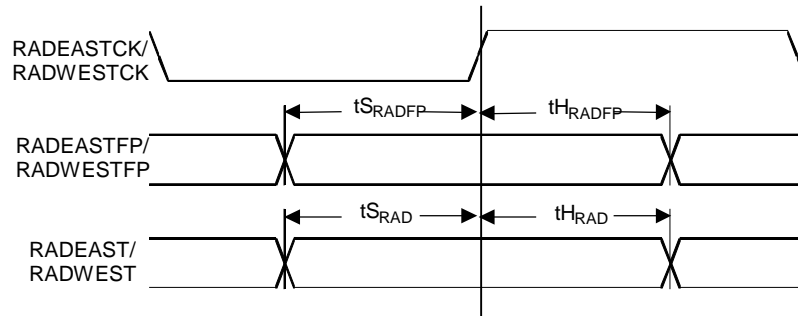
1. Intentionally left blank.
2. Guaranteed by design for nominal XCLK input frequency (37.056 MHz  $\pm$ 100 ppm).
3. CTCLK can be a jittered clock signal subject to the minimum high and low times shown. These specifications correspond to nominal XCLK input frequency of 37.056 MHz  $\pm$ 100 ppm.
4. High pulse width is measured from the 1.4 Volt points of the rise and fall ramps. Low pulse width is measured from the 1.4 Volt points of the fall and rise ramps.
5. XCLK frequency must be 24x the line rate  $\pm$ 32 ppm when TJAT is free-running or referenced to a derivative of XCLK. XCLK may be  $\pm$  100 ppm if an accurate reference is provided to TJAT.

6. CTCLK can be a jittered clock signal subject to the minimum high and low durations  $t_{HCTCLK}$ ,  $t_{LCTCLK}$ . These durations correspond to nominal XCLK input frequency.
7. When a set-up time is specified between an input and a clock, the set-up time is the time in nanoseconds from the 1.4 Volt point of the input to the 1.4 Volt point of the clock.
8. When a hold time is specified between an input and a clock, the hold time is the time in nanoseconds from the 1.4 Volt point of the clock to the 1.4 Volt point of the input.
9. Setup, hold, and propagation delay specifications are shown relative to the default active clock edge, but are equally valid when the opposite edge is selected as the active edge.
10. Output propagation delay time is the time in nanoseconds from the 1.4 Volt point of the reference signal to the 1.4 Volt point of the output.
11. Output propagation delays are measured with a 50 pF load on all outputs with the exception of the high speed DS3 outputs (TCLK, TPOS/TDAT, TNEG/TMFP). The TCLK, TPOS/TDAT, TNEG/TMFP output propagation delays are measured with a 20 pF load.

**Table 47: Remote Serial Alarm Port Timing**

Symbol	Description	Min	Max	Units
	RADEASTCK and RADWESTCK Frequency	1.344	10	MHz
	RADEASTCK and RADWESTCK Duty Cycle	40	60	%
$t_{HRADFP}$	RADEASTFP and RADWESTFP Hold Time	5		ns
$t_{SRADFP}$	RADEASTFP and RADWESTFP Setup Time	5		ns
$t_{HRAD}$	RADEAST and RADWEST Hold Time	5		ns
$t_{SRAD}$	RADEAST and RADWEST Setup Time	5		ns

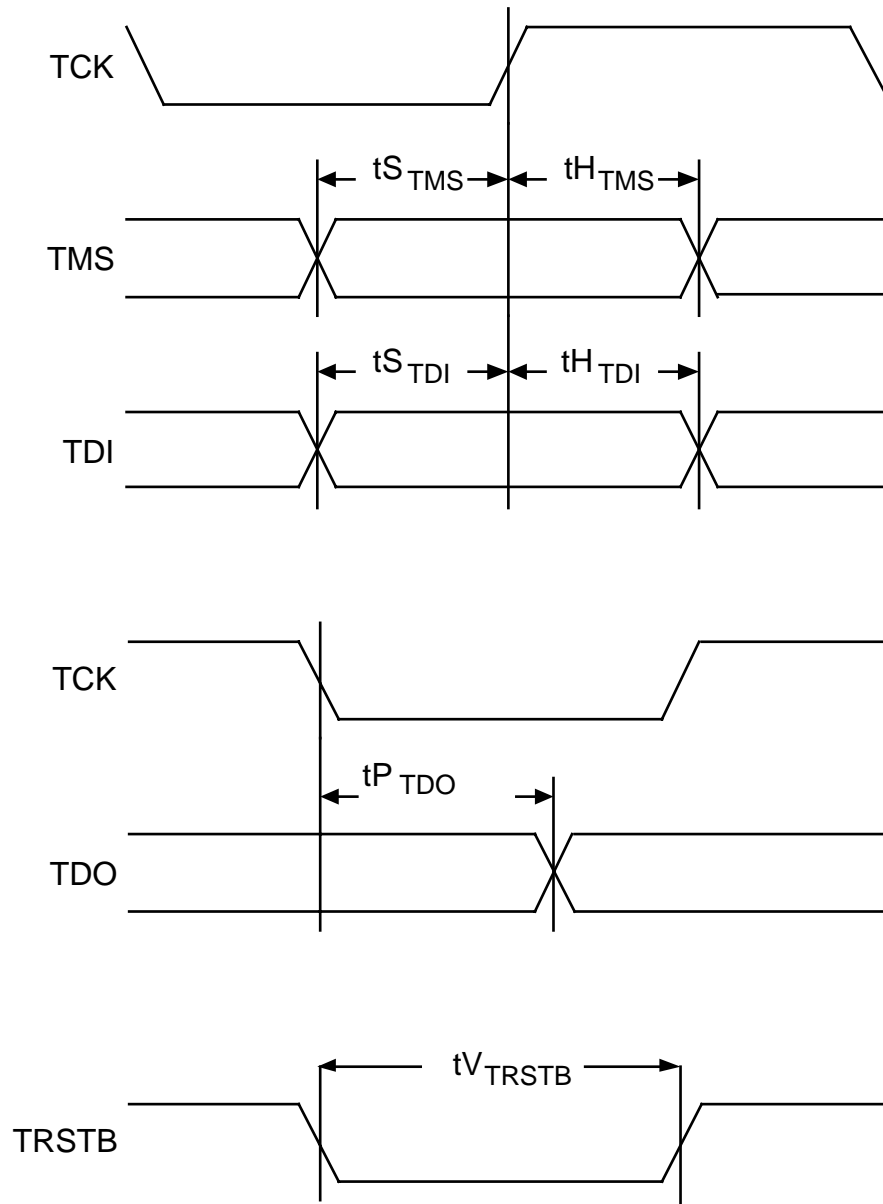
**Figure 69: Remote Serial Alarm Port Timing**



**Table 48: JTAG Port Interface**

Symbol	Description	Min	Max	Units
	TCK Frequency		1	MHz
	TCK Duty Cycle	40	60	%
tSTMS	TMS Set-up time to TCK	50		ns
tHTMS	TMS Hold time to TCK	100		ns
tSTDI	TDI Set-up time to TCK	50		ns
tHTDI	TDI Hold time to TCK	100		ns
tPTDO	TCK Low to TDO Valid	2	100	ns
tVTRSTB	TRSTB Pulse Width	100		ns

**Figure 70: JTAG Port Interface Timing**



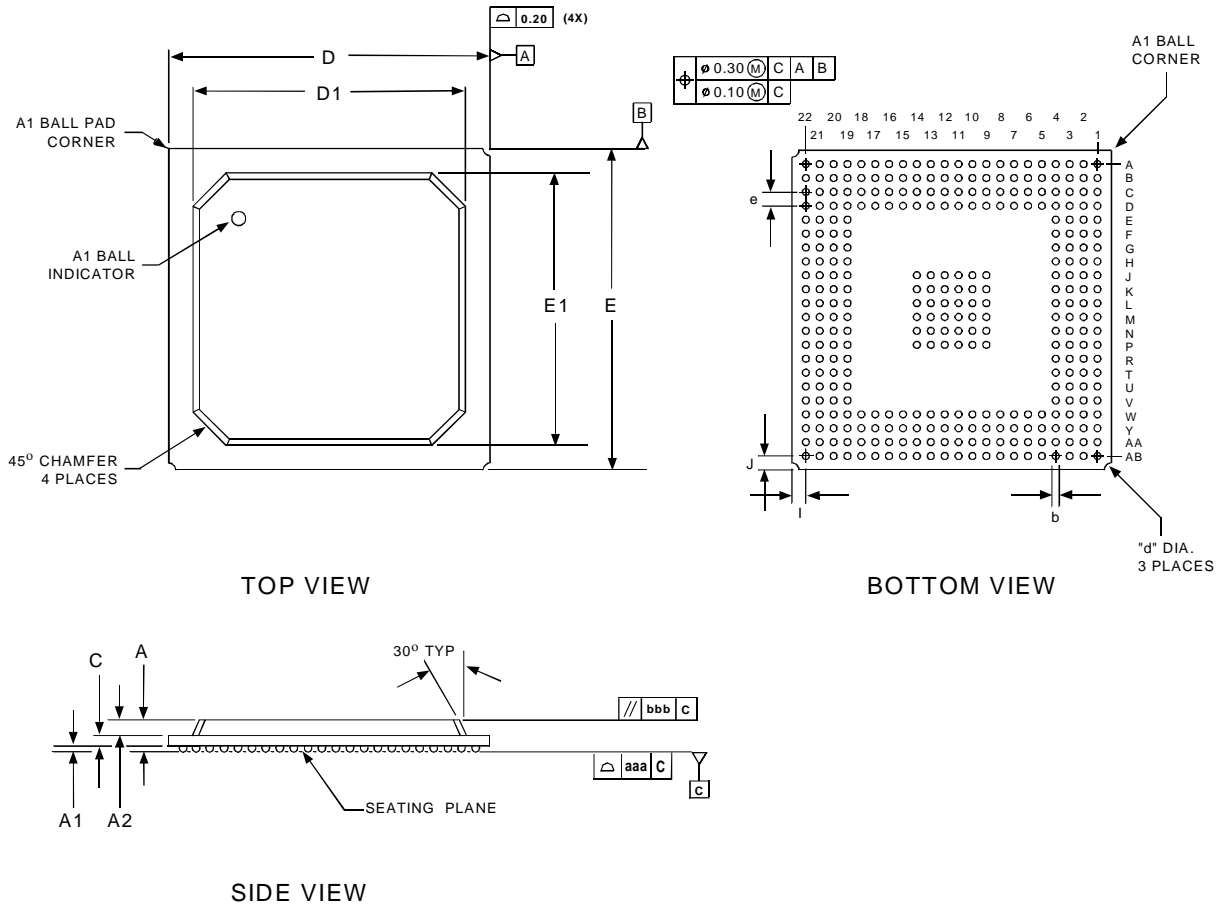
**18 ORDERING AND THERMAL INFORMATION**

**Table 49 - Ordering and Thermal Information**

<b>Part No.</b>	<b>Description</b>
PM5365-PI	324 Plastic Ball Grid Array (PBGA)

**19 MECHANICAL INFORMATION**

**Figure 71: 324 Pin PBGA 23x23mm Body**



- NOTES: 1) ALL DIMENSIONS IN MILLIMETER.  
 2) DIMENSION aaa DENOTES COPLANARITY.  
 3) DIMENSION bbb DENOTES PARALLEL.

PACKAGE TYPE : 324 PLASTIC BALL GRID ARRAY - PBGA																	
BODY SIZE : 23 x 23 x 2.33 MM (4 layer)																	
Dim.	A (2 layer)	A (4 layer)	A1	A2	D	D1	C (2 layer)	C (4 layer)	E	E1	I	J	b	d	e	aaa	bbb
Min.	1.35	1.55	0.30	0.75	-	19.00	0.30	0.50	-	19.00	-	-	0.40	-	-	-	-
Nom.	1.56	1.76	0.40	0.80	23.00	19.50	0.36	0.56	23.00	19.50	1.00	1.00	0.50	1.00	1.00	-	-
Max.	1.75	1.97	0.50	0.85	-	20.20	0.40	0.62	-	20.20	-	-	0.60	-	-	0.15	0.35

**NOTES**

**NOTES**

**CONTACTING PMC-SIERRA, INC.**

PMC-Sierra, Inc.  
105-8555 Baxter Place Burnaby, BC  
Canada V5A 4V7

Tel: (604) 415-6000

Fax: (604) 415-6200

Document Information: [document@pmc-sierra.com](mailto:document@pmc-sierra.com)  
Corporate Information: [info@pmc-sierra.com](mailto:info@pmc-sierra.com)  
Application Information: [apps@pmc-sierra.com](mailto:apps@pmc-sierra.com)  
Web Site: <http://www.pmc-sierra.com>

None of the information contained in this document constitutes an express or implied warranty by PMC-Sierra, Inc. as to the sufficiency, fitness or suitability for a particular purpose of any such information or the fitness, or suitability for a particular purpose, merchantability, performance, compatibility with other parts or systems, of any of the products of PMC-Sierra, Inc., or any portion thereof, referred to in this document. PMC-Sierra, Inc. expressly disclaims all representations and warranties of any kind regarding the contents or use of the information, including, but not limited to, express and implied warranties of accuracy, completeness, merchantability, fitness for a particular use, or non-infringement.

In no event will PMC-Sierra, Inc. be liable for any direct, indirect, special, incidental or consequential damages, including, but not limited to, lost profits, lost business or lost data resulting from any use of or reliance upon the information, whether or not PMC-Sierra, Inc. has been advised of the possibility of such damage.

© 2000 PMC-Sierra, Inc.

PMC-1991148 (P2) ref PMC-990691 (P2) Issue date: February 2000