

Under Development
Preliminary

MITSUBISHI LASER DIODES
ML1XX16 SERIES
FOR OPTICAL INFORMATION SYSTEMS

TYPE
NAME

ML101J16, ML120G16

This type is under development. Therefore, please note that this data sheet may be changed without any notice.

DESCRIPTION

ML1XX16 is a high-power, high-efficient AlGaInP semiconductor laser which provides a stable, single transverse mode oscillation with emission wavelength of 660-nm and standard pulse light output of 70mW.

ML1XX16 has a real-index-waveguide which improves the slope efficiency (reduction of the operating current) and the astigmatic distance.

Also, ML1XX16 has a window-mirror-facet which improves the maximum output power. That leads to highly reliable and high-power operation.

FEATURES

- High Output Power: 70mW (Pulse)
- High Efficiency: 0.90W/A (typ.)
- Visible Light: 660nm (typ.)
- Low Astigmatic Distance: 1 μ m (typ.)

APPLICATION

Portable High-Density Optical Disc Drives
Re-Writable DVD Drives

ABSOLUTE MAXIMUM RATINGS (Note 1)

Symbol	Parameter	Conditions	Ratings	Unit
Po	Light output power	CW	50	mW
		Pulse(Note 2)	70	
VRL	Reverse voltage	-	2	V
Tc	Case temperature	-	-10 ~ +70	°C
Tstg	Storage temperature	-	-40 ~ +100	°C

Note1: The maximum rating means the limitation over which the laser should not be operated even instant time. This does not mean the guarantee of its lifetime. As for the reliability, please refer to the reliability report issued by Quality Assurance Section, HF & Optical Semiconductor Division, Mitsubishi Electric Corporation.

Note2: TARGET SPEC /Condition Duty Cycle: less than 50%, pulse width: less than 0.1 μ s

ELECTRICAL/OPTICAL CHARACTERISTICS (Tc=25°C)

Symbol	Parameter	Test conditions	Min.	Typ.	Max	Unit
I _{th}	Threshold current	CW	-	36	-	mA
I _{op}	Operating current	CW, Po=50mW	-	92	-	mA
V _{op}	Operating voltage	CW, Po=50mW	-	2.4	3.0	V
η	Slope efficiency	CW, Po=50mW	-	0.9	-	mW/mA
λ_p	Peak wavelength	CW, Po=50mW	655	660	666	nm
$\theta_{//}$	Beam divergence angle (parallel)	CW, Po=50mW	7	9	12	°
θ_{\perp}	Beam divergence angle (perpendicular)	CW, Po=50mW	18	20	22	°

MITSUBISHI LASER DIODES
ML1XX16 SERIES
 FOR OPTICAL INFORMATION SYSTEMS

OUTLINE DRAWINGS

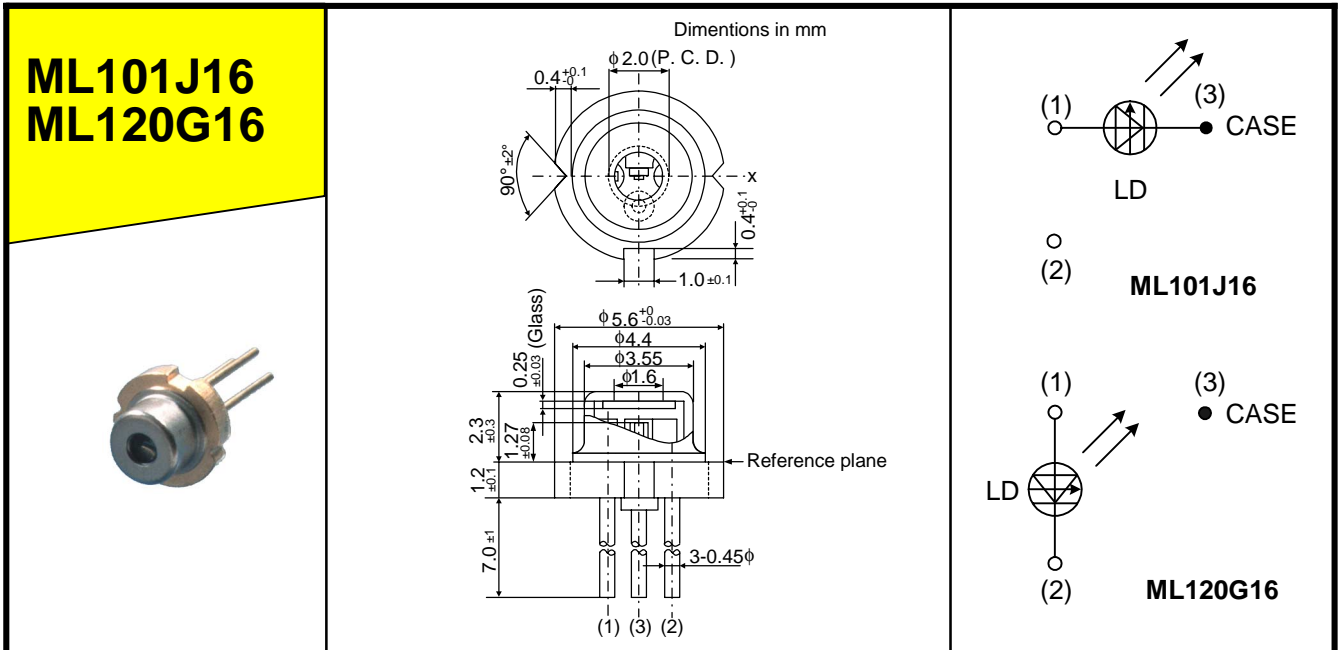

There is no model with a monitor photo diode in ML1XX16 series.

TENTATIVE CHARACTERISTICS (Reference Data)

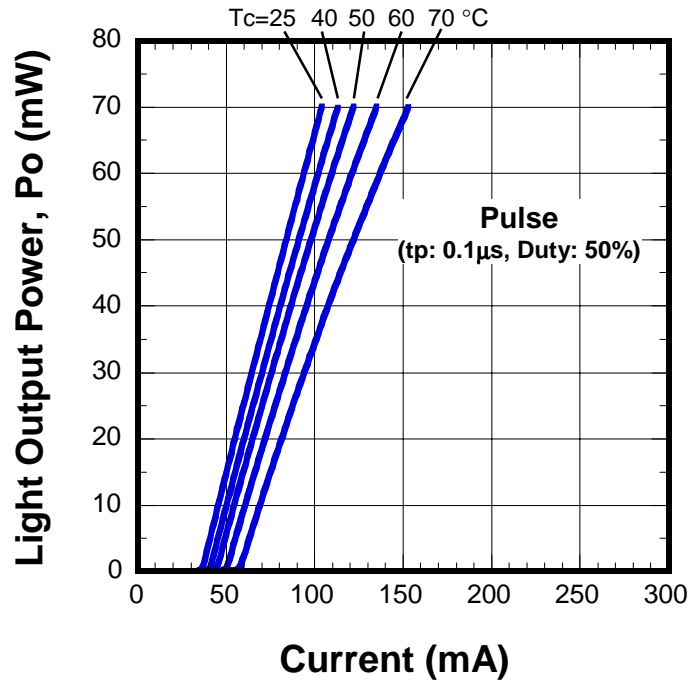

Light Output Power vs. Current (Pulse)

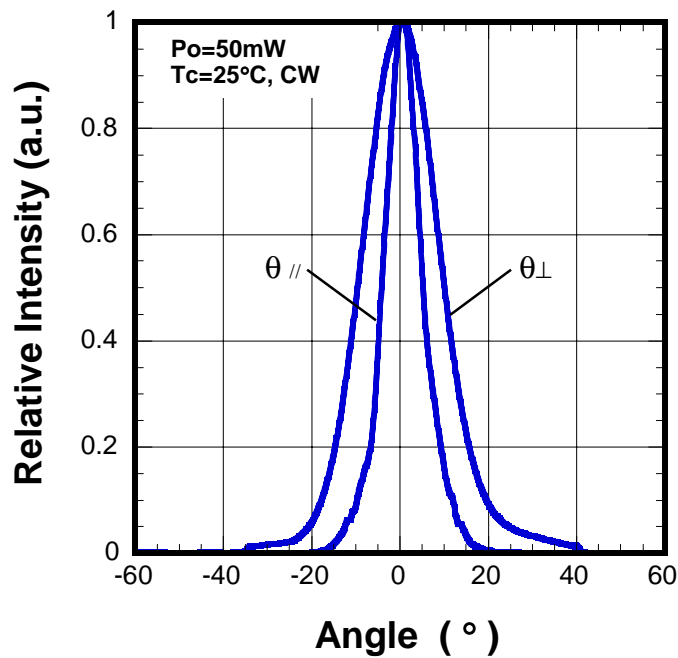

Far Field Patterns