

Contents

Features	1
Applications	1
Functions.....	1
Block Diagram	1
Terminals.....	2
Absolute Maximum Ratings (Ta=25 °C).....	3
Recommended Operating Conditions.....	3
Electrical Characteristics (Ta=25 °C, VDD=3.0 V) ...	4
Electrical Characteristic Curves	4

DISCONTINUED PRODUCT

RECEIVER IC FOR INFRARED REMOTE CONTROLLER

S-8270A

The S-8270A is a CMOS IC developed for infrared remote control System. A photodetecting PIN diode can be directly connected. An input amplifier, limiter amplifier, band-pass filter, detector and an output waveform shaper are contained in a one-chip.

■ Features

Characteristics

- Power supply voltage : 2.4 to 6.0 V ($I_{IN}=30\ \mu\text{A}$)
- Current consumption: 0.13 mA typ. 0.25 mA max. at 3.0 V

Hardware functions

- Incorporates band-pass filter (possible to adjust resonance frequency by external resistance: $f_0=30$ to 46KHz)
- Incorporates trap filter
- Possible to connect input terminal directly to photodetecting PIN diode
- Output logic is active "LOW"
- Output is generated N-channel open drain with pull-up resistor (Possible to connect output terminal directly to TTL or CMOS)

Package

- 8-pin SOP: S-8270AFE
- 8-pin DIP : S-8270ADP

■ Applications

- Infrared remote control encoder for TVs, VCRs, audio devices
- Infrared remote control TOYS

■ Functions

The S-8270A amplifies the voltage converted from the current signal of the PIN diode, which is coupled directly to S-8270A, at the reception of the infrared.

The signal, then, goes through the band-pass filter for noise reduction before being input to the discriminator. The discriminator recovers the transmitted data out of a burst signal. Finally the data are shaped by the signal shaping circuit.

■ Block diagram

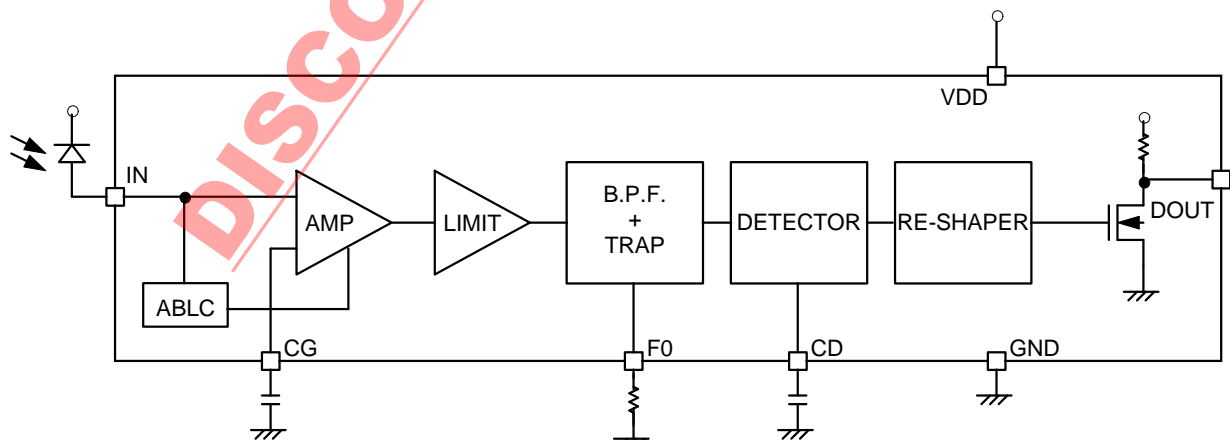

Figure 1

RECEIVER IC FOR INFRARED REMOTE CONTROLLER
S-8270A

■ **Terminals**

1. Pin assignment (Top view)

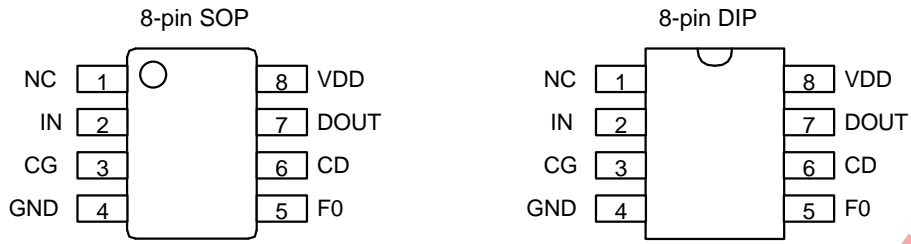

Figure 2

DISCONTINUED PRODUCT

3. Terminal Description

Table 1

Terminal No.	Symbol	External parts	Description
1	NC		<ul style="list-style-type: none"> No connection
2	IN	Photodetecting PIN diode	<ul style="list-style-type: none"> Input terminal which connects photodetecting PIN diode. Internal impedance is 50 kΩ typ. Therefore a photodetecting PIN diode can be directly connected. ABL (Automatic Bias Level Control) prevent from saturation of input level
3	CG	1500pF to 0.01μF	<ul style="list-style-type: none"> Input terminal which connects condenser to AMP gain control.
4	VSS		<ul style="list-style-type: none"> GND potential terminal.
5	F0	24K Ω	<ul style="list-style-type: none"> Input terminal which connects resistance to adjust resonance frequency of band-pass filter (f₀=30 to 46KHZ) TRAP AMP. prevent from illegal action which is caused by high frequency noise of fluorescent lamp.
6	CD	200pF	<ul style="list-style-type: none"> Input terminal which connects condenser to adjust detector circuit.
7	DOUT		<ul style="list-style-type: none"> Output terminal which output logic is active "LOW". Output is generated at N-channel open drain with pull-up resistor, which is easily interfaced to next stage circuit.
8	VDD		<ul style="list-style-type: none"> Positive power supply

■ Absolute Maximum Ratings (Ta=25 °C)

Table 2

Item	Symbol	Rating	Unit
Storage temperature	T _{stg}	-40 to +125	°C
Operating ambient temperature	T _{opr}	-30 to +85	°C
Power supply voltage	V _{DD}	-0.3 to +7.0	V
Input voltage	V _{IN}	0 to V _{DD}	V
Output voltage	V _{OUT}	0 to V _{DD}	V
Power dissipation	P _d	200	mW

■ Recommended Operating Conditions

Table 3

Item	Symbol	Conditions	Min.	Typ.	Max.	Unit
Power supply voltage	V _{DD}	I _{IN} =30 μA	2.4		6.0	V
		I _{IN} =300 μA	2.7		6.0	V
Input frequency	f _{in}		30		46	KHz
Condenser for AMP gain control	CG			2000		pF
Resistor to adjust resonance frequency of band-pass filter	F0	f _{IN} =38 KHz		24		KΩ
Condenser to adjust detector circuit	CD			200		pF

RECEIVER IC FOR INFRARED REMOTE CONTROLLER S-8270A

■ Electrical Characteristics (Ta=25 °C, V_{DD}=3.0 V)

Table 4

Item	Symbol	Conditions	Min.	Typ.	Max.	Unit
Operating current consumption	I _{DD}	V _{IN} =V _{SS}	—	0.13	0.25	mA
AMP gain	AV	f _{in} =38 KHz V _{IN} =30 μVp-p (*1)	77	80	83	dB
Resonance frequency of band-pass filter	f ₀	V _{IN} =300 μVp-p (*1)	—	38	—	KHz
Band width of band-pass filter	f _{BW}	-3dB band width f ₀ =38 KHz	2.0	2.5	3.0	KHz
Output pulse width	tpw	f _{in} =38 KHz BW V _{IN} =50 mVp-p (*2)	440	—	770	μS
Low level output voltage	V _{OL}	I _{OL} =0.1 mA	—	—	0.4	V
High level output current	I _{OH}	V _{OH} =V _{DD}	-1	—	1	μA
Input resistance	R _{IN}	I _{IN} =300 μA (*3)	30	50	70	KΩ
Input voltage 1	V _{IN1}	I _{IN} =0 μA	—	0	—	V
Input voltage 2	V _{IN2}	I _{IN} =300 μA	0.5	1.2	1.8	V
Output pull-up resistance	R _{OUT}	V _{DD} =3.0V	50	100	200	KΩ

(*1) V_{IN} is input voltage

(*2) Input (burst wave)

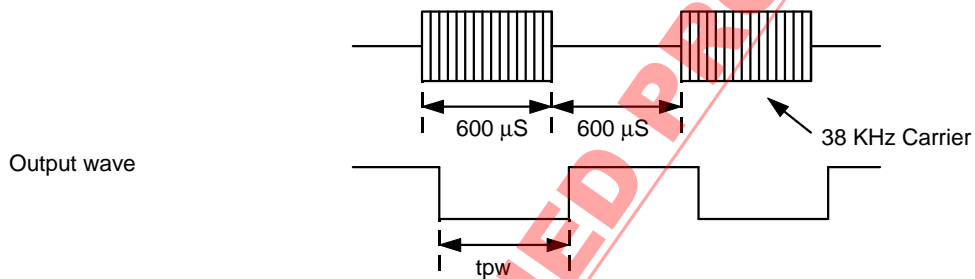

(*3) V_{IN} : Input voltage, Vr : Measurement voltage

$$R_{IN} = \frac{50}{V_{IN}/V_r - 1} \text{ [K}\Omega\text{]}$$

■ Electrical Characteristic Curves

(1) Voltage Gain - Frequency

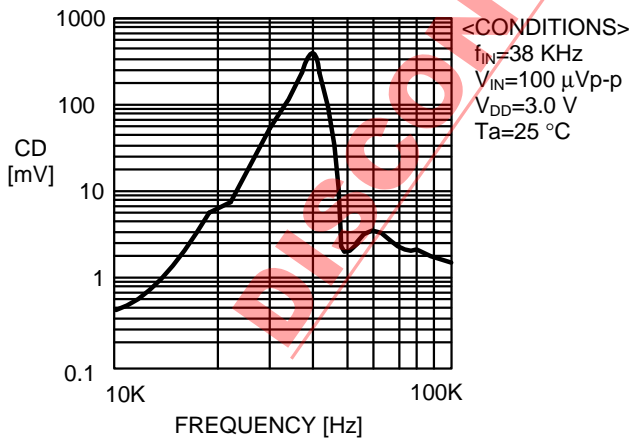

(2) AMP Gain - External Condenser

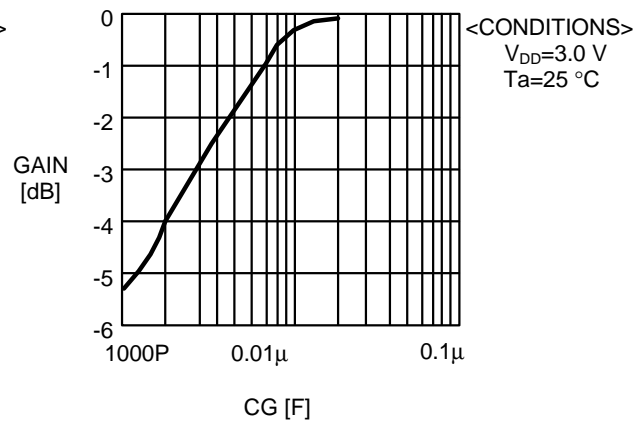

(3) Input - Output

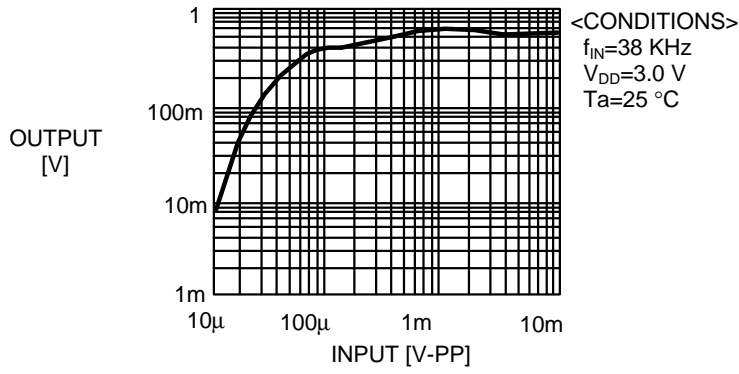

(4) V_{DD} - Operating current

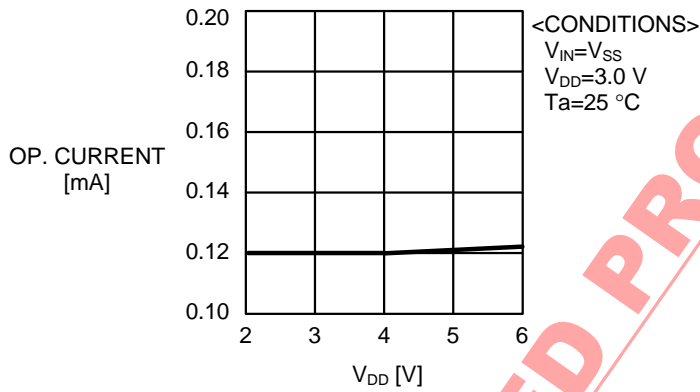

(5) B.P.F frequency - External Resistor

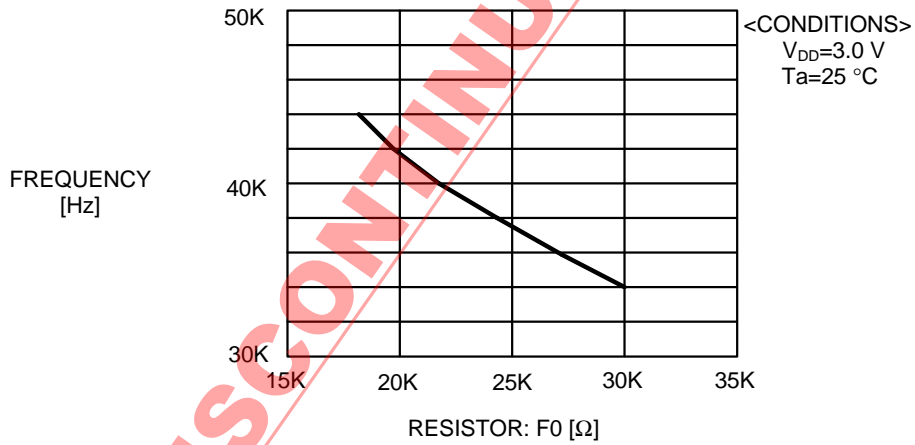

8-pin SOP

FE008-D 990531

Dimensions

Unit:mm

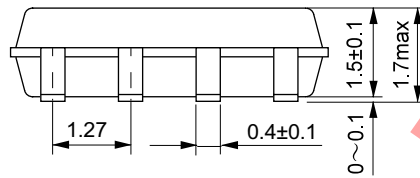
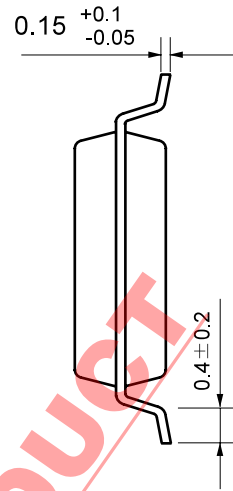
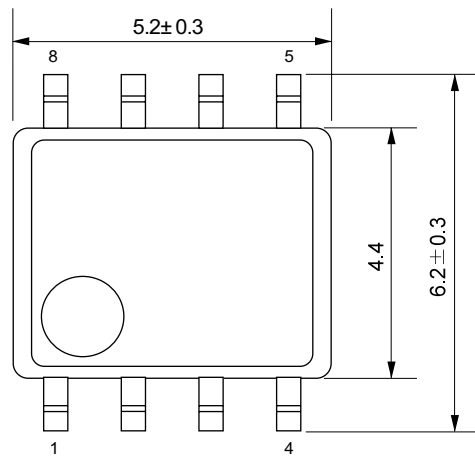

No. : FE008-D-P-SD-1.0

Taping Specifications

Reel Specifications

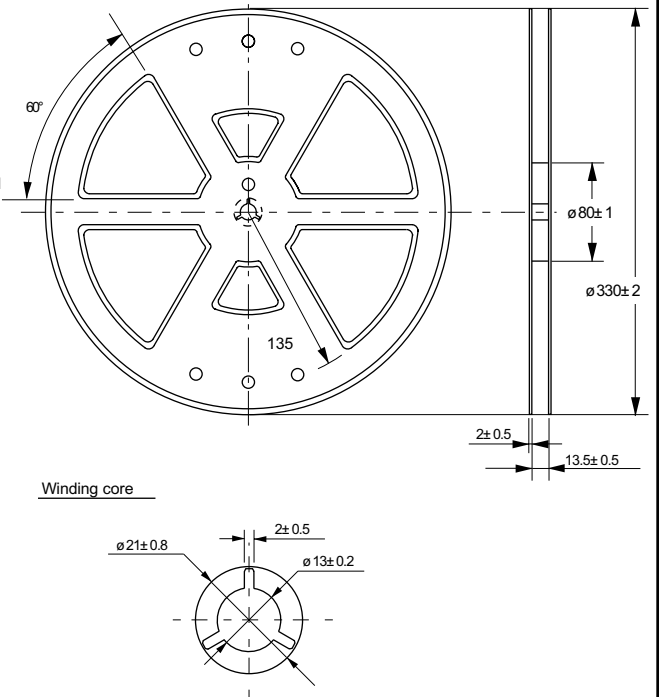
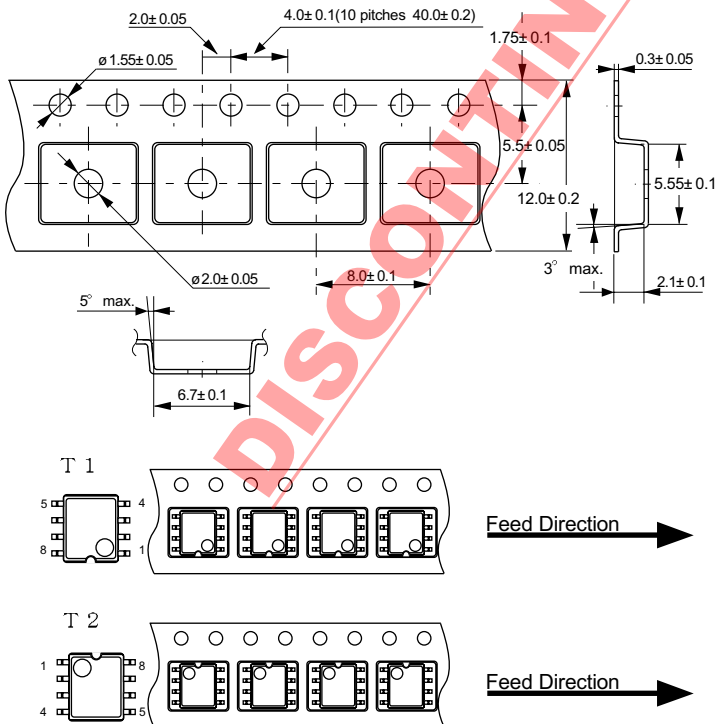

No. : FE008-A-C-SD-1.0

No. : FE008-A-R-SD-1.0

■ 8-pin DIP

DP008-A 990531

● Dimensions

Unit:mm

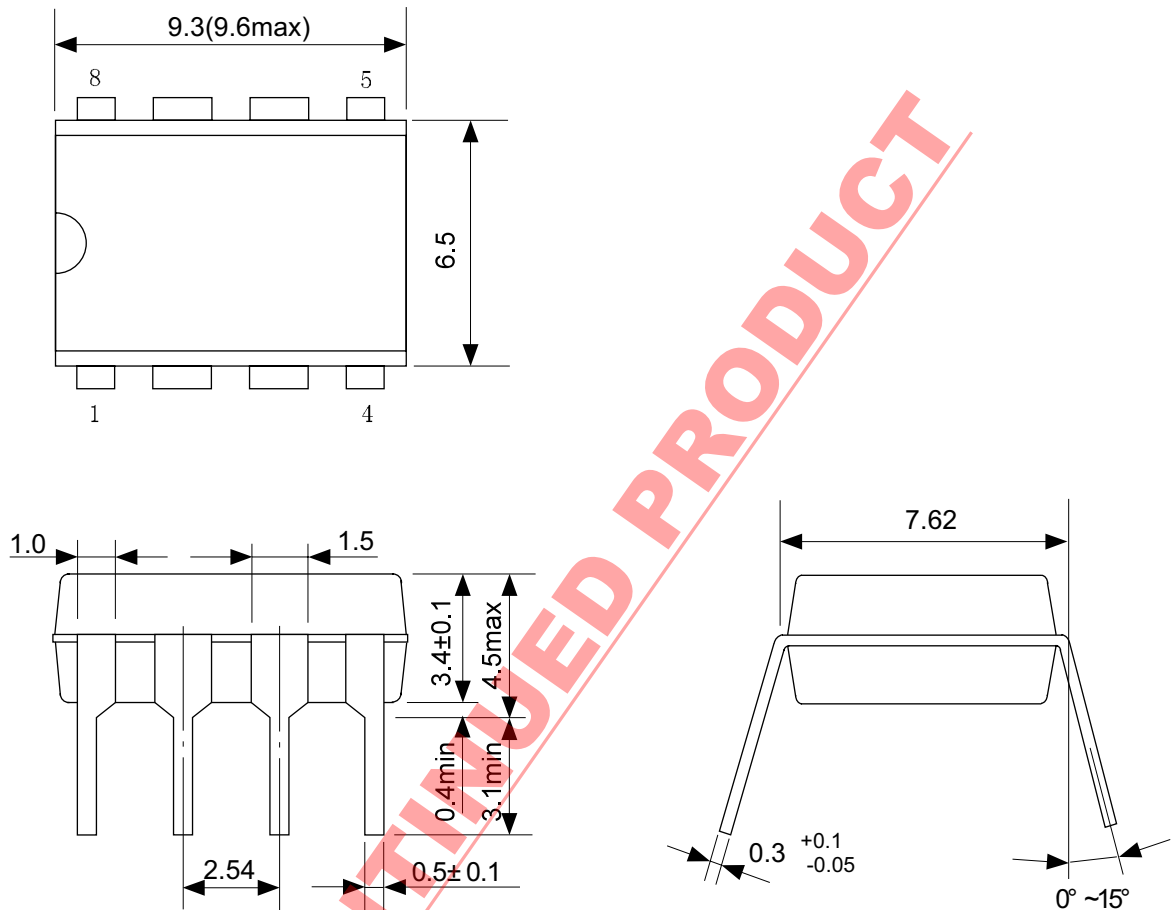

No. : DP008-A-P-SD-1.0

DISCONTINUED PRODUCT

DISCONTINUED PRODUCT

- The information herein is subject to change without notice.
- Seiko Instruments Inc. is not responsible for any problems caused by circuits or other diagrams described herein whose industrial properties, patents or other rights belong to third parties. The application circuit examples explain typical applications of the products, and do not guarantee any mass-production design.
- When the products described herein include Strategic Products (or Service) subject to regulations, they should not be exported without authorization from the appropriate governmental authorities.
- The products described herein cannot be used as part of any device or equipment which influences the human body, such as physical exercise equipment, medical equipment, security system, gas equipment, vehicle or airplane, without prior written permission of Seiko Instruments Inc.