

PLASTI-GRIP

TE Part # 52263-1

TE Internal #: 52263-1

[View on TE.com >](#)



Terminals & Splices > Rings & Spades



Terminal & Splice Type: **Ring Tongue**

Wire Size: 13100 – 20800 CMA

Stud Size: #10

Features

Product Type Features

Shape Description	RING-044
Stud Size	#10
Barrel Type	Closed Barrel
Sealable	No
Insulated	Yes
Wire/Cable Type	Regular Wire
Support Style	Insulation Support

Configuration Features

Number of Holes	1
Terminal Angle	Straight

Electrical Characteristics

Voltage (Max)	600 V
---------------	-------

Body Features

Inspection Slot	No
Plating Material	Copper, Tin

Contact Features

Terminal & Splice Type	Ring Tongue
Terminal Orientation	Offset

Mechanical Attachment

Wire Insulation Support	With
-------------------------	------



Dimensions

Wire Size	13100 – 20800 CMA
Stud Diameter	5 mm[.197 in]
Tongue Thickness	1.02 mm[.04 in]
Overall Length	4.318 mm[.17 in]
Wire Insulation Diameter	8.38 mm[.33 in]

Usage Conditions

Operating Temperature Range	105 °C[221 °F]
-----------------------------	----------------

Operation/Application

Heavy Duty	No
------------	----

Industry Standards

Government Qualified	No
----------------------	----

Packaging Features

Packaging Quantity	100
Packaging Method	Loose Piece

Product Compliance

[For compliance documentation, visit the product page on TE.com>](#)

EU RoHS Directive 2011/65/EU	Compliant
EU ELV Directive 2000/53/EC	Compliant
China RoHS 2 Directive MIIT Order No 32, 2016	No Restricted Materials Above Threshold
EU REACH Regulation (EC) No. 1907/2006	Current ECHA Candidate List: JAN 2019 (197) Candidate List Declared Against: JUL 2017 (174)
Halogen Content	Not Low Halogen - contains Br or Cl > 900 ppm.
Solder Process Capability	Not applicable for solder process capability

Product Compliance Disclaimer

This information is provided based on reasonable inquiry of our suppliers and represents our current actual knowledge based on the information they provided. This information is subject to change. The part numbers that TE has identified as EU RoHS compliant have a maximum concentration of 0.1% by weight in homogenous materials for lead, hexavalent chromium, mercury, PBB, PBDE, DBP, BBP, DEHP, DIBP, and 0.01% for cadmium, or qualify for an exemption to these limits as defined in the Annexes of Directive 2011/65/EU (RoHS2). Finished electrical and electronic equipment products will be CE marked as required by Directive 2011/65/EU. Components may not be CE marked. Additionally, the part numbers that TE has identified as EU ELV compliant have a maximum concentration of 0.1% by weight in homogenous materials for lead, hexavalent chromium, and mercury, and 0.01% for cadmium, or qualify for an exemption to these limits

as defined in the Annexes of Directive 2000/53/EC (ELV). Regarding the REACH Regulations, TE's information on SVHC in articles for this part number is still based on the European Chemical Agency (ECHA) 'Guidance on requirements for substances in articles'(Version: 2, April 2011), applying the 0.1% weight on weight concentration threshold at the finished product level. TE is aware of the European Court of Justice ruling of September 10th, 2015 also known as O5A (Once An Article Always An Article) stating that, in case of 'complex object', the threshold for a SVHC must be applied to both the product as a whole and simultaneously to each of the articles forming part of its composition. TE has evaluated this ruling based on the new ECHA "Guidance on requirements for substances in articles" (June 2017, version 4.0) and will be updating its statements accordingly.

Compatible Parts

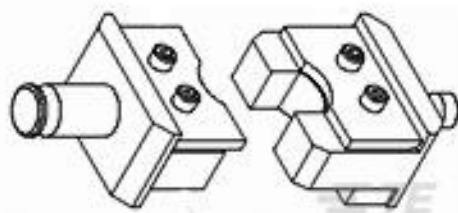

TE Part # 47820
DIE TERMINYL 69051 #8



TE Part # 48858-1
DIE AMPLI-BOND 69066 #8



TE Part # 1490597-1
DIE ASSEMBLY,TERMINL #8



TE Part # 1490534-1
DIE ASSEMBLY,AMPLI-BOND #8

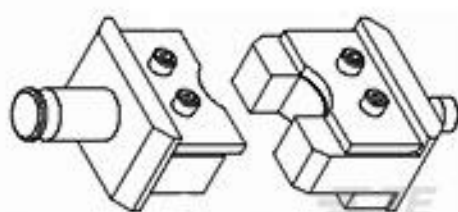

TE Part # 48752-1
DIE AMPLI-BOND 69051 #8



TE Part # 69959
HHHT AMPLI-BOND

Customers Also Bought



TE Part #205206-8
HDP-20,PLUG,SIZE 2, 15 POSN



TE Part #1658649-1
KIT,HDP-20,OVRMLD, RCPT,SIZE 3,

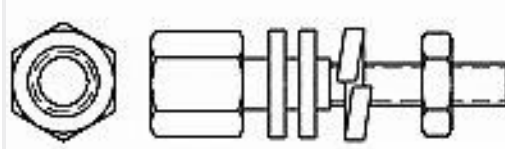

TE Part #5747223-3
AMPLI FEM S'LOCK KIT



TE Part #3-747580-1
SHLDNG FERRULE, PLTD, BULK PKG



TE Part #52041-1
TERMINAL,R PG 8 1/4



TE Part #52041-3
TERMINAL,R PG 8 1/4



TE Part #3-747579-4
SHLDNG FERRULE, PLTD, BULK PKG



TE Part #52265
TERMINAL R PG 6 10



Documents

Product Drawings

[TERMINAL R PG 8 10](#)

English

CAD Files

Customer View Model

[ENG_CVM_CVM_52263-1_AA.2d_dxf.zip](#)

English

[3D PDF](#)

3D

Customer View Model

[ENG_CVM_CVM_52263-1_AA.3d_igs.zip](#)

English

Customer View Model

[ENG_CVM_CVM_52263-1_AA.3d_stp.zip](#)

English

Product Specifications

[Application Specification](#)

English

Product Environmental Compliance

[TE Material Declaration](#)

English

Instruction Sheets

[Instruction Sheet \(U.S.\)](#)

English

Agency Approvals

[UL Report](#)

English

[UL Report](#)

English
