

- NOTE:
- MAT'L: .035 THK., BRASS, #2 TEMPER (HALF HARD), PER ETCO METAL CODE NO. 05085.
  - MAT'L: .035 THK., PRE-TINNED BRASS, #2 TEMPER (HALF HARD), PER ETCO METAL CODE NO. 01870.
  - PARTS MAY BE COATED WITH A LIGHT FILM OF LUBRICATION USED IN THE MANUFACTURING PROCESS.
  - DIMENSIONS DO NOT INCLUDE BULGE DUE TO FORMING.
  - .0015 BURR ALLOWED.
  - WIRE RANGE: 10 AWG.

P/C	DESCRIPTION	DIM 'X'	MAT'L
04612	S412E-1/4-THB	.270-.260	NOTE 2
04613	S412E-262-HB	.267-.257	NOTE 1

Rev.	Description of Change/ SCN#	Date
-	INITIAL RELEASE SCJ	2-26-03
1	ECR# 3277 SCJ	9/16/14

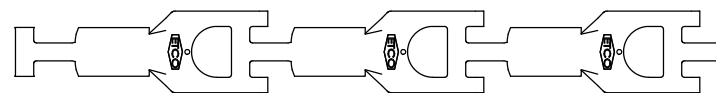
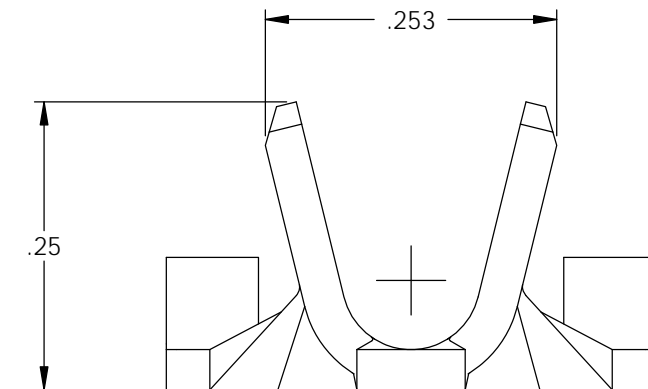
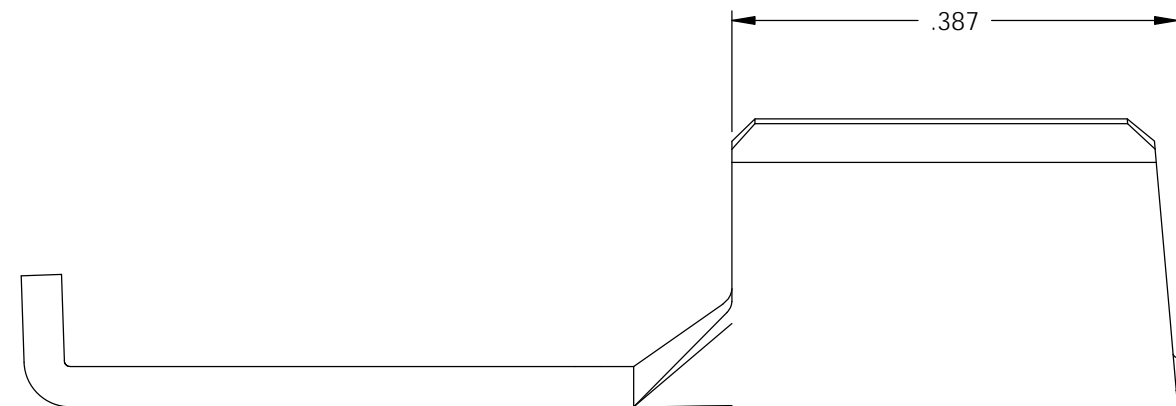
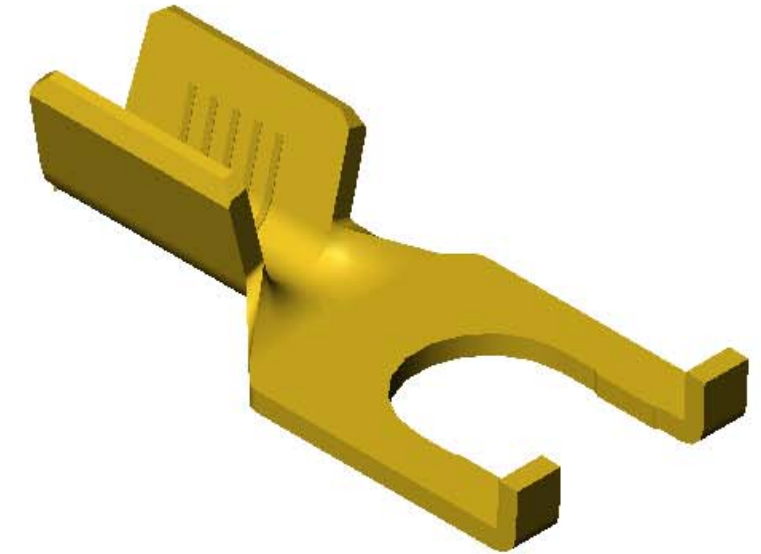
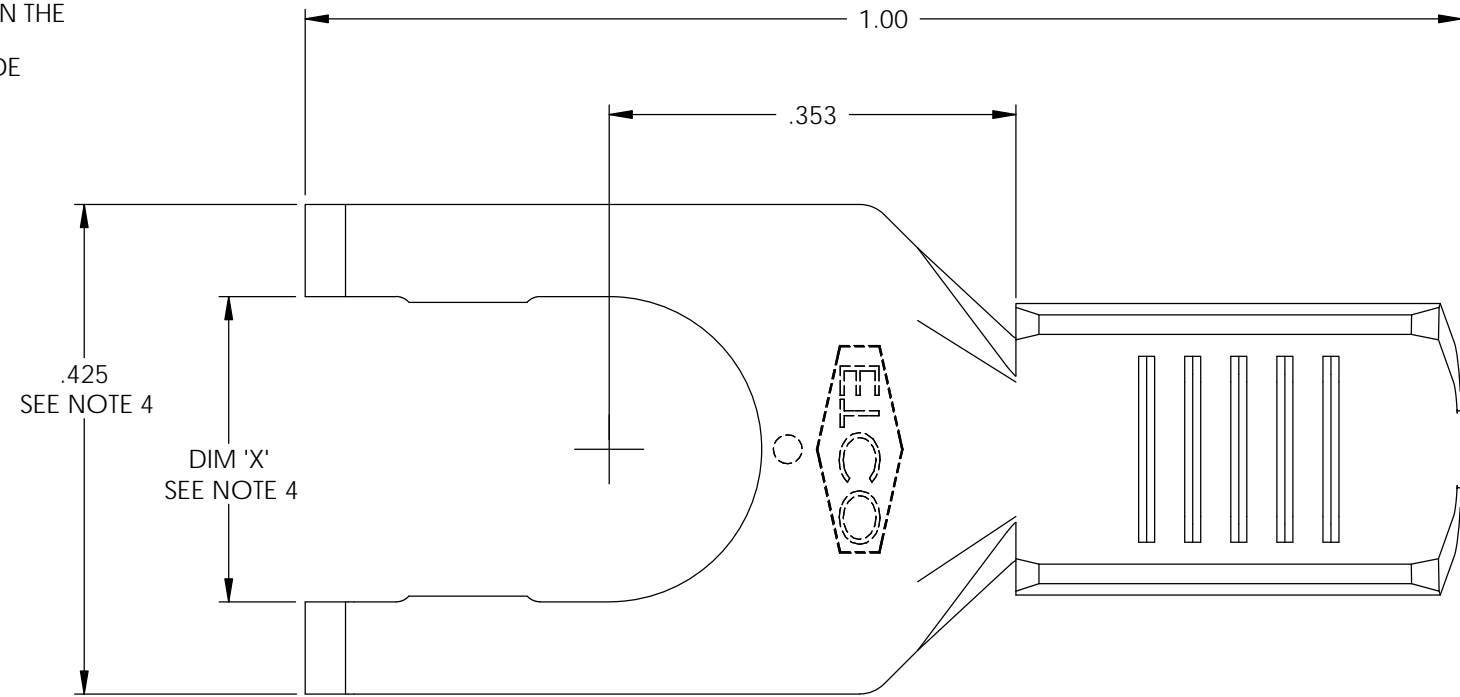

DIRECTION EXITING TOOL,  
EARS DOWN, TO THE LEFT

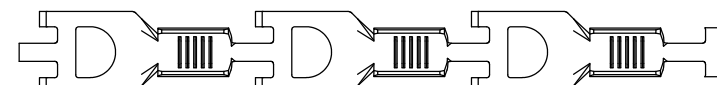

DIRECTION TOWARD APPLICATOR,  
EARS UP, TO THE RIGHT

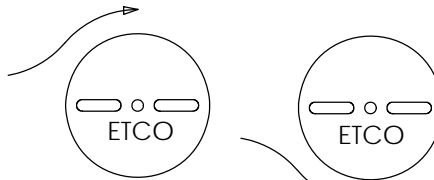

THIS PRINT IS THE PROPERTY OF ETCO INCORPORATED. NO PART OF THIS DESIGN MAY BE USED IN ANY WAY WITHOUT WRITTEN CONSENT FROM ETCO INCORPORATED.

# UNCONTROLLED COPY

<p>THIRD ANGLE PROJECTION TOLERANCES UNLESS OTHERWISE SPECIFIED INCHES: .XX - ±.030 .XXX - ±.015 ANGLES: ±5°</p>	<p>TOOL NO. <b>0790</b></p>	<p>Title: <b>SPADE TERMINAL</b></p>		
		<p>DO NOT SCALE DWG.</p>	<p>Drawn By: S. JOHNSON</p>	<p>Date: 2-26-03</p>
<p>ETCO Incorporated Engineered Products 25 Bellows Street Warwick, RI 02888 Phone: (401) 467-2400 Fax: (401) 467-9230 www.ETCO.com</p>		<p>Chk'd/App'd By:</p>	<p>Scale: 6X</p>	<p>Size B</p>
		<p>Dwg. No.: <b>S412E cust</b></p>		