

# HD81901

---

## Single Chip Modem Supporting V.27ter/bis and V.26/bis

### Description

The HD81901 is a single chip CMOS LSI modem based on the ITU-T V.27ter/bis and V.26/bis standards. It can be used in the All Japan Bank network protocol, in the JCA protocol, and in JUST-PC, PC, CAPTAIN, and general data communications. This LSI incorporates modulator and demodulator circuits, transmission and reception filters, a V.24 interface, and the other circuits necessary in a modem. By using this LSI, a modem system for use in PC and data communications can be constructed easily.

### Features

- Can handle the All Japan Bank, JCA, JUST-PC, and CAPTAIN protocols
  - ITU-T standards  
V.26, V.26bis  
V.27ter, V.27bis  
V.23 (BWC)
  - Four wire full duplex and two wire half duplex operation
  - Built-in transmission and reception filters
  - Transmission and detection of all tone types (Arbitrary frequency transmission and detection possible)
  - Built-in DTMF generator
  - Transmission level adjustment possible (0 dBm to -31 dBm)
  - Reception level adjustment possible
  - Three type of equalizer built in
    - Adaptive auto-equalizer
    - Subscriber line equalizer
    - Fixed delay equalizer (2 links)
  - NCU control pins (3 inputs and 3 outputs)
  - Loop test
  - Eye pattern generation signal output available
- Low power CMOS (350 mW typ.)
  - Wide operating temperature range (-20 to +75 °C)
  - Single voltage +5 V power supply
  - Package lineup includes:
    - 64 pin plastic shrink DIP (DP-64S)
    - 80 pin QFP (FP-80B)
    - 68 pin PLCC (CP-68)

### Functions

- ITU-T standards (Data transmission speeds)
  - V.27ter: 4.8k/2.4k bps
  - V.27bis: 4.8k/2.4k bps
  - V.26bis: 2.4k/1.2k bps
  - V.26: 2.4k bps
  - V.23 (BW): 75 bps
- Training signal  
V.27ter/bis: long/short
- DTMF signal transmission  
Level difference between higher and lower group frequency settable
- Transmission and detection of all tone types  
2100 Hz (default), 1800 Hz (default), 400 Hz (default) and arbitrarily settable detection frequency

### Ordering Information

Type Number	Package
HD81901PS2	DP-64S
HD81901CPS2	CP-68
HD81901FS2	FP-80B

# HD81901

## Pin Arrangement

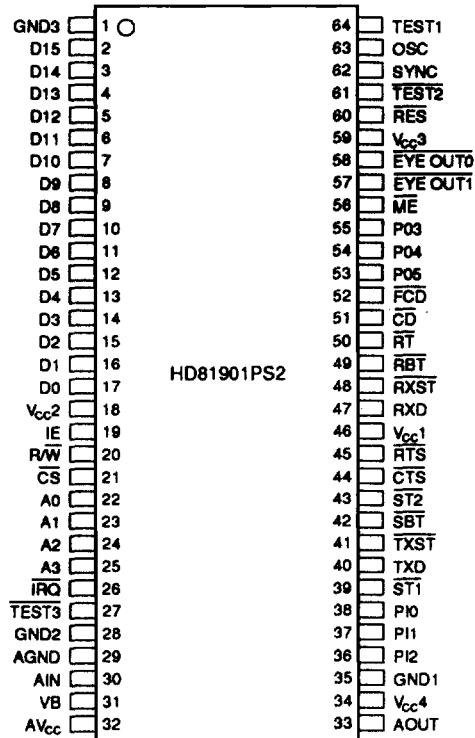

(Top view)

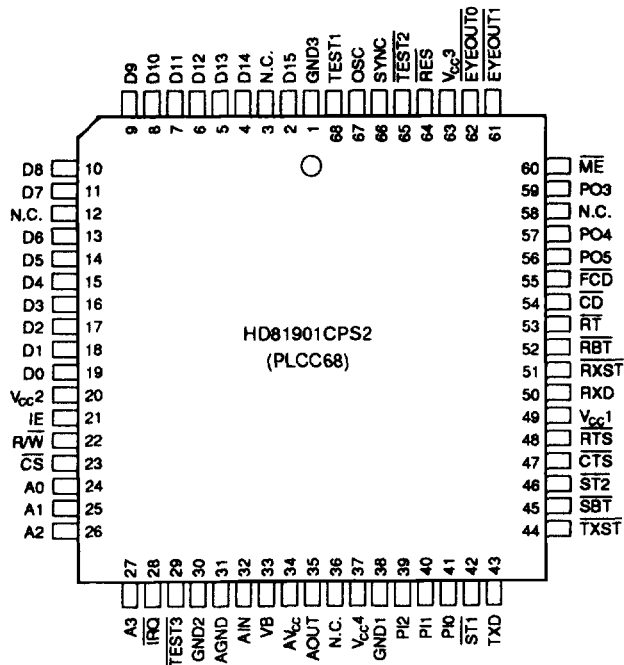

(Top view)

N.C.: Not connected to internal chip

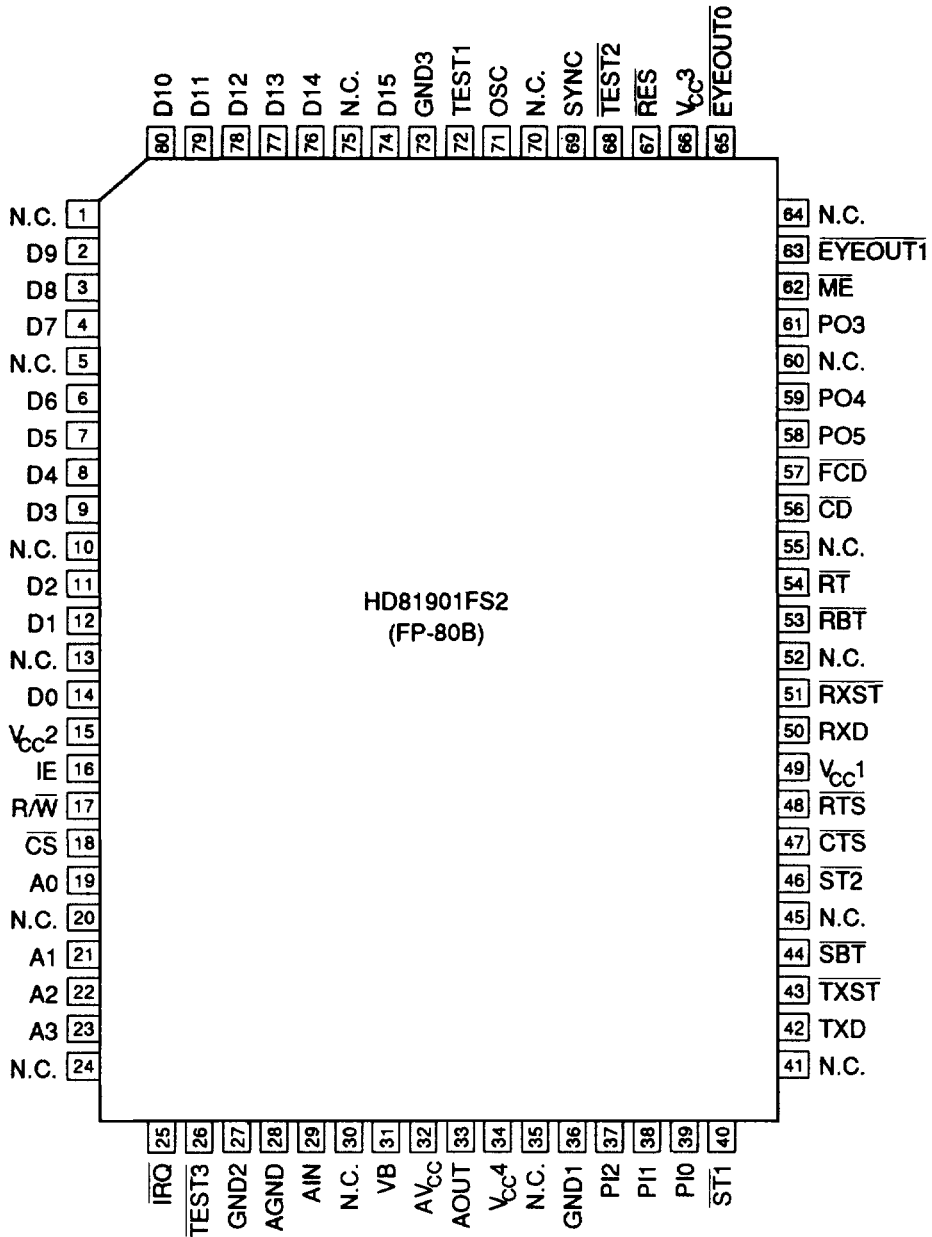

(Top view)

N.C.: Not connected to internal chip

# HD81901

## Electrical Characteristics

### Absolute Maximum Ratings

Item	Symbol	Rated Value	Units
Power supply voltage *1	$V_{CC}$	-0.3 to +7.0	V
Analog power supply voltage	$AV_{CC}$	-0.3 to +7.0	V
Digital power supply voltage	$V_{IND}$	-0.3 to $V_{CC} + 0.3$	V
Analog input voltage	$V_{INA}$	-0.3 to $V_{CC} + 0.3$	V
Operating temperature	$T_{DDR}$	-20 to +75	°C
Storage temperature	$T_{stg}$	-55 to +125	°C
Storage temperature (when bias voltage applied)	$T_{bias}$	-20 to +85	°C

Note: \*1.  $V_{CC1} = V_{CC2} = V_{CC3} = V_{CC4} = AV_{CC}$  GND1 = GND2 = GND3 = AGND

DC Characteristics ( $V_{CC1} = V_{CC2} = V_{CC3} = V_{CC4} = AV_{CC} = 5.0 \text{ V} \pm 5\%$ , GND1 = GND2 = GND3 = AGND = 0 V,  $T_a = -20$  to +75°C, unless otherwise noted)

Item	Symbol	Min.	Typ.	Max.	Units	Applicable Pins	Measurement Conditions
Digital input high level voltage	$V_{IH1}$	2.4	—	$V_{CC} + 0.3$	V	OSC	
	$V_{IH2}$	2.4	—	$V_{CC} + 0.3$	V	*1	
	$V_{IH3}$	$V_{CC} \times 0.7$	—	$V_{CC} + 0.3$	V	RES	
Digital input low level voltage	$V_{IL1}$	-0.3	—	0.6	V	OSC	
	$V_{IL2}$	-0.3	—	0.6	V	*1	
	$V_{IL3}$	-0.3	—	0.6	V	RES	
Digital input leakage current	$ I_{in} $	—	—	10	$\mu\text{A}$	*1 OSC	$V_{IN} = 0.4\text{--}2.4 \text{ V}$
Digital three state (off state) current	$ I_{Tst} $	—	—	10	$\mu\text{A}$	*2	$V_{IN} = 0.4\text{--}2.4 \text{ V}$
Digital output high level voltage	$V_{OH}$	2.4	—	—	V	*3	$-I_{OH} = 400 \mu\text{A}$
Digital output low level voltage	$V_{OL}$	—	—	0.4	V	*3	$I_{OL} = 1.6 \text{ mA}$
Pull-up current	$I_{PULL}$	—	—	400	$\mu\text{A}$	*4	$V_{IN} = 0 \text{ V}$
Analog input leakage current	$ I_{IA} $	—	—	10	$\mu\text{A}$	$A_{IN}$	$V_{IN} = 0 \text{ V}$
	$ I_{IA} $	—	—	10	$\mu\text{A}$	$A_{IN}$	$V_{IN} = AV_{CC} = 5.0 \text{ V}$
Analog input resistance	$R_{IA}$	1	—	—	$\text{M}\Omega$	$A_{IN}$	$f = 1 \text{ kHz}$ .
Analog output resistance	$R_{OA}$	—	—	100	$\Omega$	$A_{OUT}$	
Power dissipation	$I_{CC}$	—	70	—	$\text{mA}$		

### Block Diagram

This modem is constructed to the control register, DSP, V.24 interface and host interface, and controlled by the I/O register (IR, OR, FLG) and the roll register (STATUS to RST).

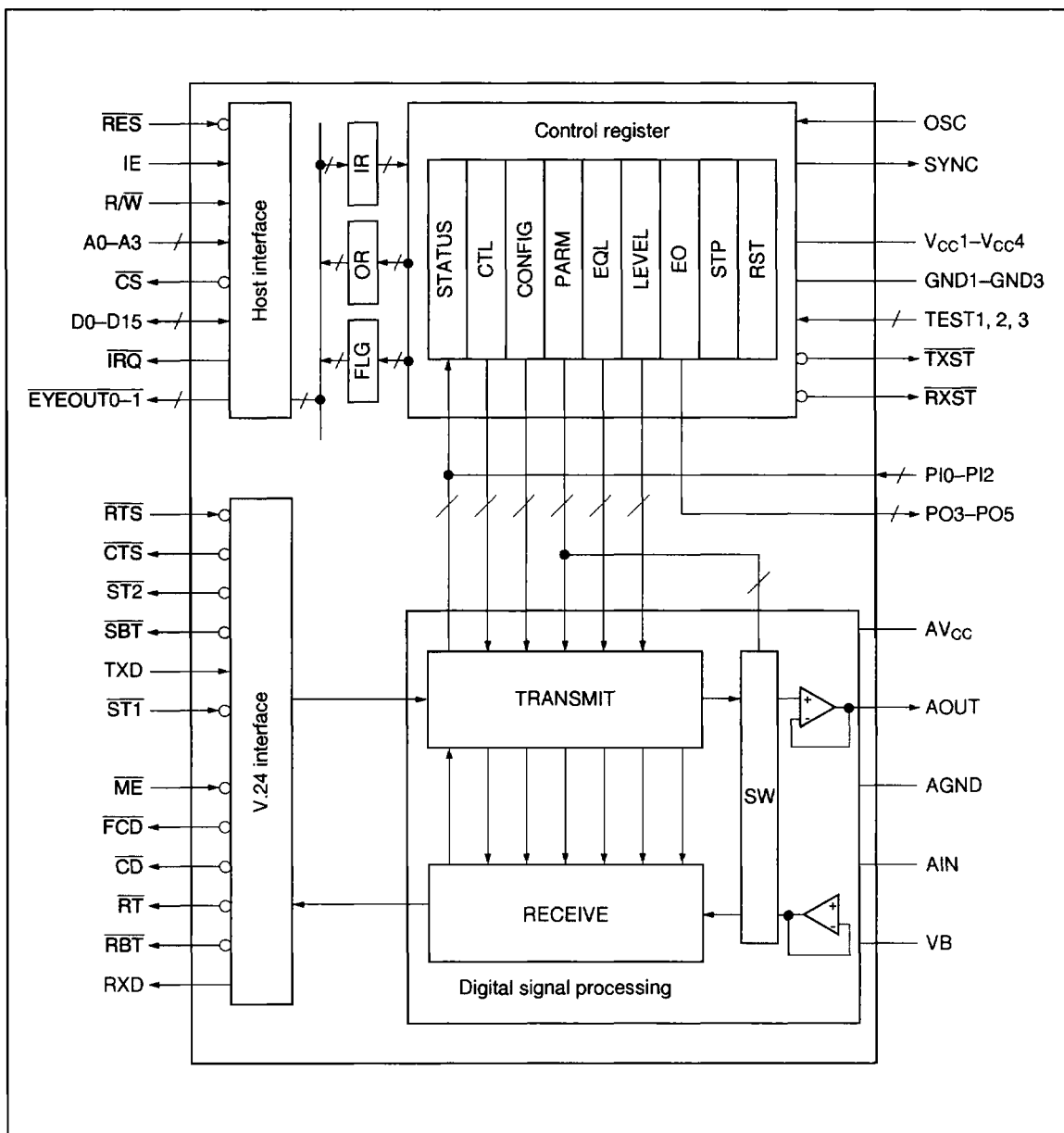

## HD81901

DC Characteristics ( $V_{CC1} = V_{CC2} = V_{CC3} = V_{CC4} = AV_{CC} = 5.0 \text{ V} \pm 5\%$ ,  $GND1 = GND2 = GND3 = AGND = 0 \text{ V}$ ,  $T_a = -20 \text{ to } +75^\circ\text{C}$ , unless otherwise noted) (cont)

Item	Symbol	Min.	Typ.	Max.	Units	Applicable Pins	Measurement Conditions
Analog reference power supply voltage	$V_B$	2.3	2.4	2.55	V	$V_B$	
Analog reference power supply current	$I_B$	—	—	10	$\mu\text{A}$	$V_B$	$V_B = 2.55 \text{ V}$
Digital input capacitance	$C_{IN}$	—	—	12.5	$\text{pF}$	All input pins other than $A_{IN}$	$f = 1 \text{ MHz}$ $V_{IN} = 0 \text{ V}$ $T_a = 25^\circ\text{C}$
Analog input capacitance	$C_{IA}$	—	—	40	$\text{pF}$	$A_{IN}$	$f = 1 \text{ MHz}$ , $V_B = 2.4 \text{ V}$
Analog output offset voltage	$V_{O\text{OFF}}$	-220	—	220	mV	$A_{OUT}$	
Analog input max. voltage	$V_{A\text{Imax}}$	—	—	2.2	$V_{PP}$	$A_{IN}$	$V_B = 2.4 \text{ V}$
Analog output max. voltage	$V_{A\text{Omax}}$	2.2	—	—	$V_{PP}$	$A_{OUT}$	When $R_L = 10 \text{ k}\Omega$ or over, $V_B = 2.4 \text{ V}$ , $C_L = 10 \text{ pF}$ or less, external +10 dB.

Notes: \*1.  $\overline{TXD}$ ,  $\overline{ST1}$ ,  $\overline{RTS}$ ,  $\overline{ME}$ ,  $\overline{PI0-PI2}$ ,  $\overline{D0-D15}$ ,  $\overline{A0-A3}$ ,  $\overline{R\overline{W}}$ ,  $\overline{CS}$ ,  $\overline{IE}$

\*2.  $\overline{D0-D15}$

\*3.  $\overline{RXD}$ ,  $\overline{RBT}$ ,  $\overline{ST2}$ ,  $\overline{SBT}$ ,  $\overline{RT}$ ,  $\overline{CTS}$ ,  $\overline{CD}$ ,  $\overline{FCD}$ ,  $\overline{IRQ}$ ,  $\overline{EYEO\text{UT}0-EYEO\text{UT}1}$ ,  $\overline{PO3-PO5}$ ,  $\overline{SYNC}$ ,  $\overline{TXST}$ ,  $\overline{RXST}$ ,  $\overline{D0-D15}$

\*4.  $\overline{IRQ}$ ,  $\overline{ST1}$ ,  $\overline{RTS}$ ,  $\overline{PI0-PI2}$ ,  $\overline{ME}$ ,  $\overline{RES}$ ,  $\overline{TEST2}$ ,  $\overline{TEST3}$

AC Characteristics ( $V_{CC1} = V_{CC2} = V_{CC3} = V_{CC4} = AV_{CC} = 5.0\text{ V} \pm 5\%$ ,  $GND1 = GND2 = GND3 = AGND = 0\text{ V}$ ,  $T_a = -20\text{ to }+75^\circ\text{C}$ , unless otherwise noted)

Item	Symbol	Min.	Typ.	Max.	Units	Applicable Pins
OSC cycle time	$\phi_{CYC}$	—	33.9	—	ns	
OSC pulse width	$\phi_{WH}, \phi_{WL}$	10	—	—	ns	
OSC rise/fall times	$\phi_r, \phi_f$	—	—	5	ns	
IE cycle time	$t_{CYC}$	0.5	—	—	$\mu\text{s}$	
IE pulse width high level	$t_{WH}$	210	—	—	ns	
IE pulse width low level	$t_{WL}$	210	—	—	ns	
IE rise time	$t_r$	—	—	25	ns	
IE fall time	$t_f$	—	—	25	ns	
CS set up time	$t_{CS}$	45	—	—	ns	
CS hold time	$t_{CH}$	10	—	—	ns	
Input data set up time	$t_{DSW}$	60	—	—	ns	
Input data hold time	$t_{DHW}$	10	—	—	ns	
Output data delay time	$t_{DDR}$	—	—	150	ns	
Output data hold time	$t_{DHR}$	20	—	—	ns	
Reset puls width	$t_{RST}$	0.5	—	—	$\mu\text{s}$	
Serial input data (TXD) set up time	$t_{TXS}$	200	—	—	ns	TXD
Serial input data (TXD) hold time	$t_{TXH}$	200	—	—	ns	TXD
ST1 rise time	$S_r$	—	—	500	ns	$\overline{ST1}$
ST1 fall time	$S_f$	—	—	500	ns	$\overline{ST1}$
Serial output data (RXD) delay time	$t_{RXD}$	—	—	250	ns	RXD

Note: \*1: OSC = 29.4912 MHz (deviation less than 100 ppm)