

REV	DESCRIPTION	BY DATE	APPD
C	ECR 7180	JHM 1/9/02	[Signature]

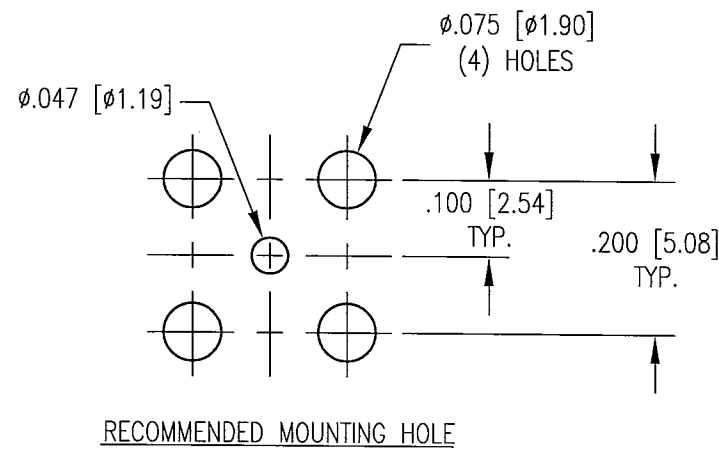
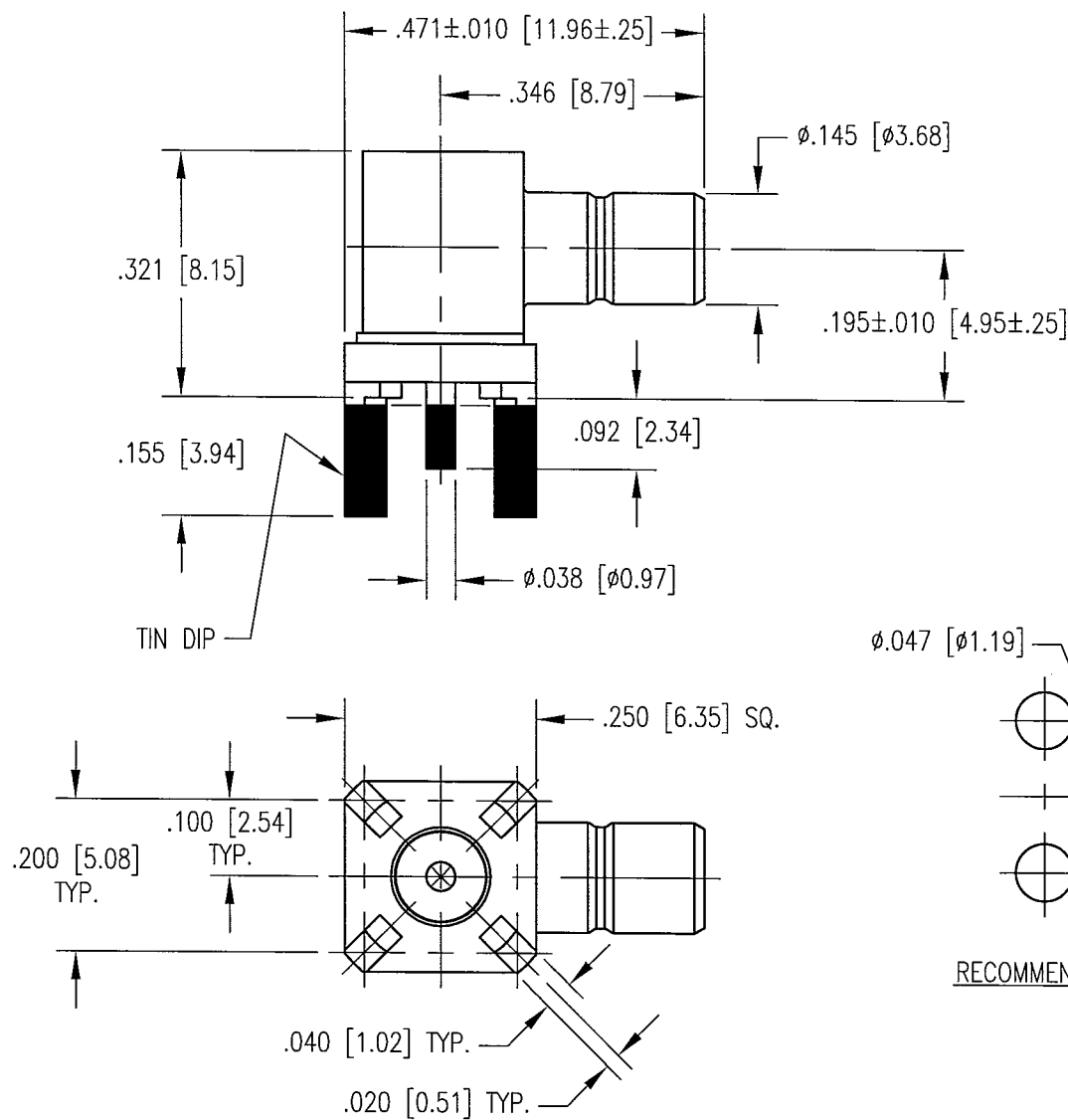

NOTES:

- MATERIALS:
 BODY AND CONTACT: BRASS PER ASTM B16
 INSULATOR: TEFLON PER ASTM D1710
- FINISH:
 BODY: .000100 MIN. NICKEL PER QQ-N-290 OVER COPPER FLASH
 CONTACT: .000030 MIN. GOLD PER MIL-G-45204 OVER .000050 MIN. NICKEL PER QQ-N-290

PER ASME Y14.5M-1994 UNLESS OTHERWISE SPECIFIED: DIMENSIONS ARE IN INCHES [MM]		Litton Winchester/Retconn 400 Park Road WaterTown, Connecticut 05795	
TOLERANCES: DECIMALS: .xx ± .01/0.254 .xxx ± .005/0.127 ANGLES ± 2°		SCALE: 4:1	
CUSTOMER DRAWING		TITLE SMB RIGHT ANGLE P.C. MOUNT	
DRAWN JED	DATE 11/24/97	CHECKED JMC	DATE 11/24/97
APPROVED PAT	DATE 11/24/97	APPROVED PAT	DATE 11/24/97
A		513-060-0046N	SHIT. OF 1 1 REV. C