

SUPER-MINIATURE OPERATION SWITCHES

TURQUOISE SNAP SWITCHES (AJN1/2)



RoHS Directive compatibility information
<http://www.nais-e.com/>

2. Hermetically sealed for superior resistance against adverse environments (dust and gas) and washing

Protective grade: The body is hermetically sealed to the level of IP67 so it can be washed as is (except terminals). Also, there will be no problem when using a standard substitute Freon cleaning solution.

(For details, please inquire.)

3. Low level rating of 0.1 A, 1 mV achieved.

Sliding contacts on both sides are used to ensure high contact reliability.

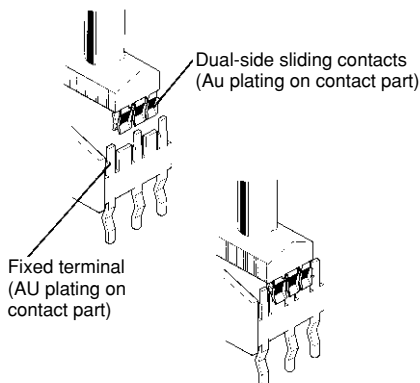

Contact movement as seen from directly above

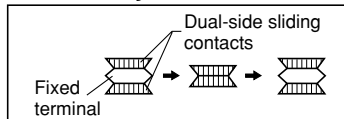

FEATURES

1. Designed to be as compatible as possible with other switches.

As shown in the table below this switch is compatible with both the toggle and push-button switches of other companies.

MEW		Other company			
		"N" company		"F" company	
		A series	B series	A series	
				1 P	2 P
PC board terminal		C	C	C	N/C
Bracket type		C	N/C	N/C	N/C
PC-H terminal	0.2 inch pitch type	C	C	C	C
	0.3 inch pitch type	—	C	C	C
PC-V terminal		C	N/C	N/C	N/C

Remark: C: compatible; N/C: not compatible

4. Resistance to static electricity of up to 20 kV at the lever tip

The operation lever is made with resin to prevent entry of static electricity into the signal circuit. However, 10 kV at the lever tip for bracket types

5. Long electrical and mechanical life achieved.

Electrical: Min. 100,000 times (0.4 VA)

Mechanical: Min. 200,000 times

6. All models use PC board independent terminals

Press fitting is possible to PC board using only light force and the fixing force prevents the switch from rising.

7. Lead free compatibility.

CONSTRUCTION

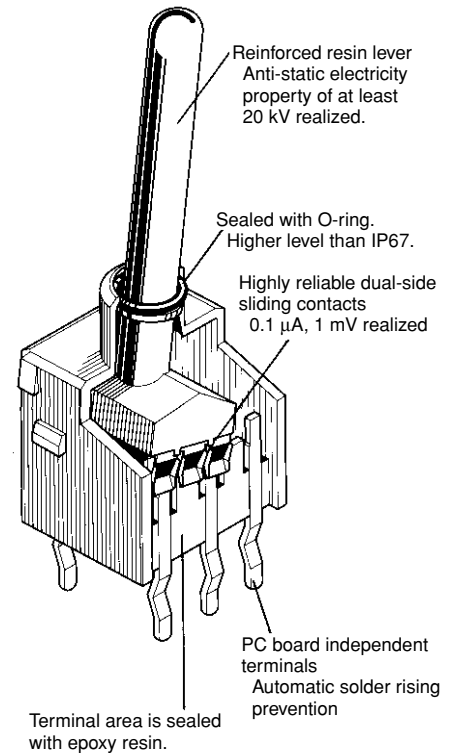









APPLICATIONS

Office automation equipment (personal computers, printers, etc.), large-scale computers, walky-talkies, professional video cameras, switching equipment, electrical measuring instruments, and control panels (robots, sequencers, elevators, etc.).

AJN1, 2







ASSORTMENT

1. Toggle series

Poles	Handle shape			Kind of operation	Terminal shape	Color of handle
	Body		Colored cap			
1-pole 2-pole	Standard toggle 	Short toggle 	Round color cap  (Option)	ON-ON ON-OFF-ON ON-<ON> <ON>-OFF-<ON> ON-OFF-<ON>	PC board terminal 	(Body) Black Red White
	Flat lever 	Short flat lever 	Rounded flat color cap  (Option)		PC-H terminal 	

Remarks: The standard handle color is black. Red or white is available for lots of 1,000 or more.
 Suffix your order number with "W" for white or "R" for red. Please consult us for other colors.
 < > indicates momentary position.

2. Push-button series

Poles	Handle shape		Kind of operation	Terminal shape	Color of handle
1-pole 2-pole	5.1 dia.  (Option)	7.5 dia.  (Option)	ON-<ON>	PC board terminal 	(Color of cap) Black Red White Light grey Blue Green Yellow
				Bracket type 	
				PC-H terminal 	
				PC-V terminal 	

Remarks: The standard handle color is black. Red or white is available for lots of 1,000 or more.
 Suffix your order number with "W" for white or "R" for red. Please consult us for other colors.
 < > indicates momentary position.

ORDERING INFORMATION

1. Toggle series

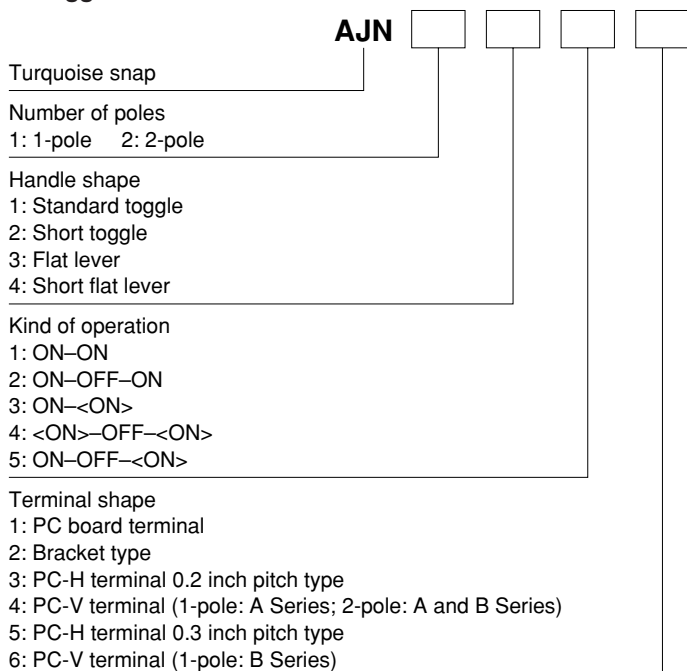

2. Push-button series

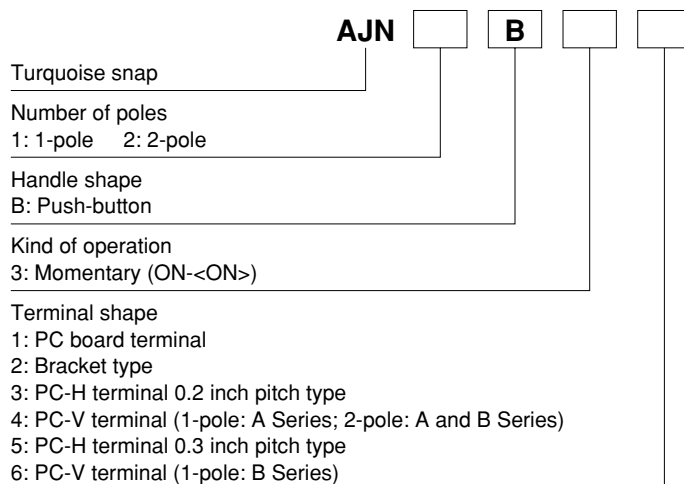

AJN1, 2

PRODUCT TYPES

1. Toggle series

Standard toggle



Change the asterisk to a "1" when ordering.

Short toggle



Change the asterisk to a "2" when ordering.

Flat lever



Change the asterisk to a "3" when ordering.

Short flat lever



Change the asterisk to a "4" when ordering.

1) PC board terminal and Bracket type

Number of poles	* ³ Kind of operation < >: Momentary position	PC board terminal		Bracket type	
		Part No.		Part No.	
1-pole	ON-ON	AJN1*11	AJN1*12	AJN1*12	AJN1*12
	ON-OFF-ON	AJN1*21	AJN1*22	AJN1*22	AJN1*22
	ON-<ON>	AJN1*31	AJN1*32	AJN1*32	AJN1*32
	<ON>-OFF-<ON>	AJN1*41	AJN1*42	AJN1*42	AJN1*42
	ON-OFF-<ON>	AJN1*51	AJN1*52	AJN1*52	AJN1*52
2-pole	ON-ON	AJN2*11	AJN2*12	AJN2*12	AJN2*12
	ON-OFF-ON	AJN2*21	AJN2*22	AJN2*22	AJN2*22
	ON-<ON>	AJN2*31	AJN2*32	AJN2*32	AJN2*32
	<ON>-OFF-<ON>	AJN2*41	AJN2*42	AJN2*42	AJN2*42
	ON-OFF-<ON>	AJN2*51	AJN2*52	AJN2*52	AJN2*52

2) PC-H terminal and PC-V terminal

Number of poles	* ³ Kind of operation < >: Momentary position	PC-H terminal		PC-V terminal	
		0.2 inch pitch type	0.3 inch pitch type	A Series	B Series
		Part No.	Part No.	Part No.	Part No.
1-pole	ON-ON	AJN1*13	AJN1*15	AJN1*14	AJN1*16
	ON-OFF-ON	AJN1*23	AJN1*25	AJN1*24	AJN1*26
	ON-<ON>	AJN1*33	AJN1*35	AJN1*34	AJN1*36
	<ON>-OFF-<ON>	AJN1*43	AJN1*45	AJN1*44	AJN1*46
	ON-OFF-<ON>	AJN1*53	AJN1*55	AJN1*54	AJN1*56
2-pole	ON-ON	AJN2*13	AJN2*15	AJN2*14	
	ON-OFF-ON	AJN2*23	AJN2*25	AJN2*24	
	ON-<ON>	AJN2*33	AJN2*35	AJN2*34	
	<ON>-OFF-<ON>	AJN2*43	AJN2*45	AJN2*44	
	ON-OFF-<ON>	AJN2*53	AJN2*55	AJN2*54	

Remarks: 1. Products that have UL and CSA markings are standard.

2. The standard handle color is black. Red or white is available for lots of 1,000 or more. Suffix your order number with "W" for white or "R" for red. Please consult us for other colors.

3. Single-side momentary operation models momentary position on the slotted side.

Combination with color caps of toggle series

Combine and use with the flat lever type.

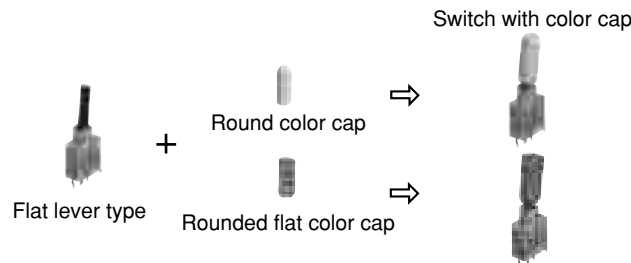

2. Push-button series

1) PC board terminal and Bracket type

Number of poles	Kind of operation < >: Momentary position	PC board terminal		Bracket type	
		Part No.		Part No.	
1-pole	ON-<ON>	AJN1B31	AJN1B32	AJN1B32	AJN1B32
2-pole	ON-<ON>	AJN2B31	AJN2B32	AJN2B32	AJN2B32

2) PC-H terminal and PC-V terminal

Number of poles	Kind of operation < >: Momentary position	PC-H terminal		PC-V terminal	
		0.2 inch pitch type	0.3 inch pitch type	A Series	B Series
		Part No.	Part No.	Part No.	Part No.
1-pole	ON-<ON>	AJN1B33	AJN1B35	AJN1B34	AJN1B36
2-pole	ON-<ON>	AJN2B33	AJN2B35	AJN2B34	

Remark: Products that have UL and CSA markings are standard.

Please use optional color cap for push-button to be fitted on body block.

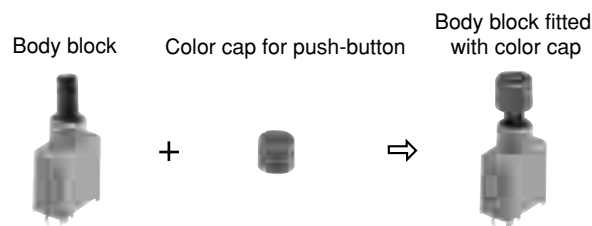

3. Color cap (option)

	Product name	Part No.
For toggle switch	Round color cap	AJN81*
	Rounded flat color cap	AJN82*
For push-button switch	5.1 dia.	AJN83*
	7.5 dia.	AJN84*

Remarks: 1. When ordering replace the asterisk with the letter that represents the color you want. B: black; R: red; W: white; H: light grey; L: blue; G: green; Y: yellow
2. For shape, please refer to the color cap dimension.

SPECIFICATIONS

1. Contact rating

Resistive load (Max.)	0.1A 30V AC/DC 50mA 48V AC/DC 0.4VA Max. AC/DC common (Applicable voltage range: 1 mV to 48 V; Applicable current range: 0.1 μA to 0.1 A)
Low-level load (Min.)	0.1μA 1mV DC

2. Characteristics

Expected life	Mechanical	Min. 2×10^5 (at 20 cpm.)
	Electrical (resistive load)	Min. 3×10^4 , 0.1 VA 30 V AC/DC, 50m A 48V AC/DC (at 20 cpm.) Min. 10^5 , 0.4 VA AC/DC (14mA 30 V, 0.1 A 4 V), 0.1 μA 1mV DC (at 20 cpm.)
Insulation resistance	Initial, Min. 500 MΩ (at 500 V DC measured by insulation resistive meter)	
Breakdown voltage	Initial, 500 Vrms (at detection current: 10mA)	
Contact resistance	Initial, Max. 50 mΩ (By voltage drop at 0.1 A, 2 to 4 V DC)	
Vibration resistance	10 to 55 Hz at double amplitude of 1.5 mm (contact opening Max. 10μs)	
Shock resistance	490 m/s ² (contact opening Max. 10μs)	
Actuator strength	Min. 14.7 N for 1 min. operating direction	
Ambient temperature	-20°C to +80 °C (Not freezing below 0 °C)	
Solderability	At least 90 % covered by 260 °C, 5 s soldering	
Soldering temperature resistance	350 °C for 3 s	
Contact material	Gold (Au) plating	

ELECTRICAL CIRCUIT DIAGRAM

Kind of operation			1-pole	2-pole
Push-button switch	Momentary ON-<ON>		5-6	2-3, 5-6
			4-5	1-2, 4-5
Toggle switch	ON-ON ON-<ON>		4-5	1-2, 4-5
		—	—	—
			5-6	2-3, 5-6
	ON-OFF-ON <ON>-OFF-<ON> ON-OFF-<ON>		4-5	1-2, 4-5
			—	—
			5-6	2-3, 5-6

Remarks: 1. Terminal number isn't stamped on switches.
 2. For ON - <ON>, ON - OFF - <ON> type toggle switches, the lever springs back (momentary position) when pushed toward the keyway side.

HANDLE SHAPE

1. Toggle series

Standard toggle	Short toggle	Flat lever	Short flat lever
With round color cap	With rounded flat color cap		

2. Push-button series

For 5.1 dia. push-button		For 7.5 dia. push-button	
With color cap	Without color cap	With color cap	Without color cap

DIMENSIONS (mm) (General tolerance: ± 0.5)

1. Toggle switch (For standard toggle)

1) PC board terminal

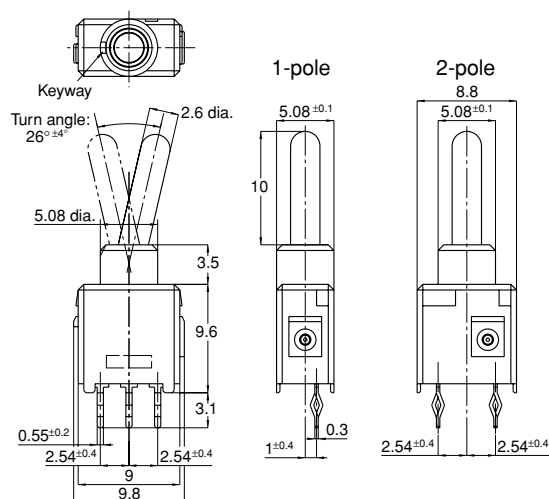

PC board pattern (Top view)

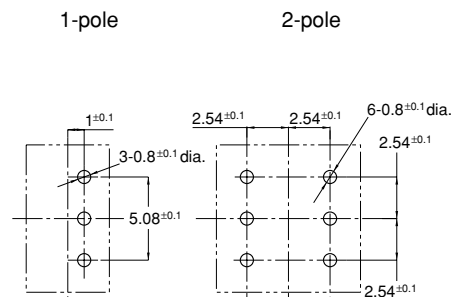

2) Bracket type

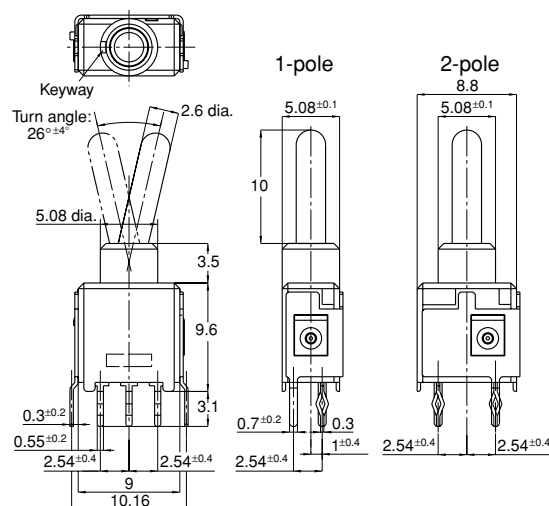

PC board pattern (Top view)

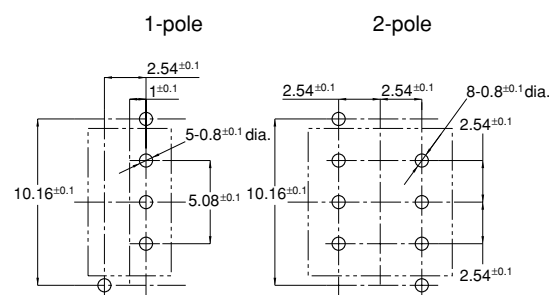

Remark: The upper side of the PC board pattern drawing is the keyway side.

3) PC-H terminal

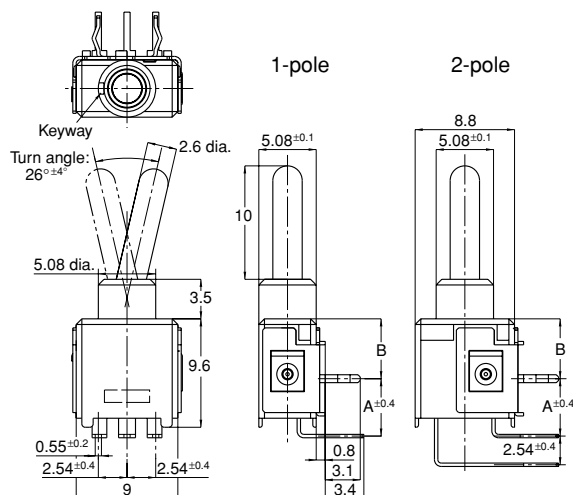

PC board pattern (Top view)

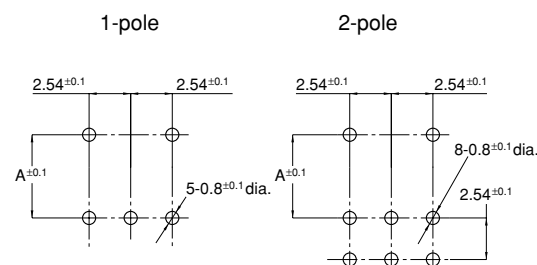

	A	B
0.2 inch pitch type	5.08	5.3
0.3 inch pitch type	7.62	2.76

AJN1, 2

- 4) PC-V terminal
- 1-pole: A Series
- 2-pole: A and B Series

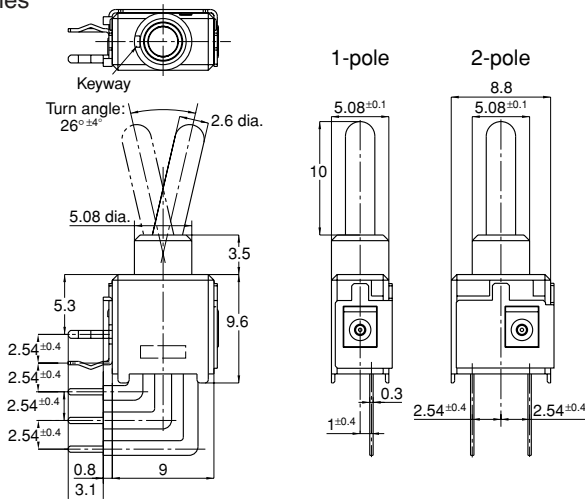

PC board pattern (Top view)

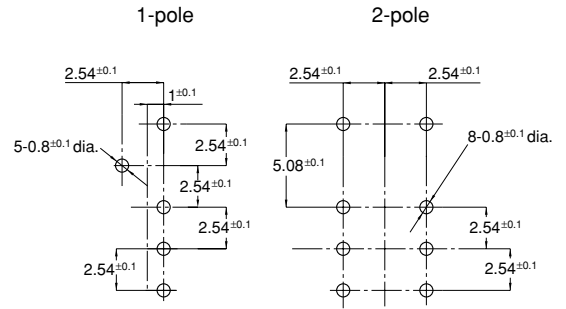

- 5) PC-V terminal
- 1-pole: B Series

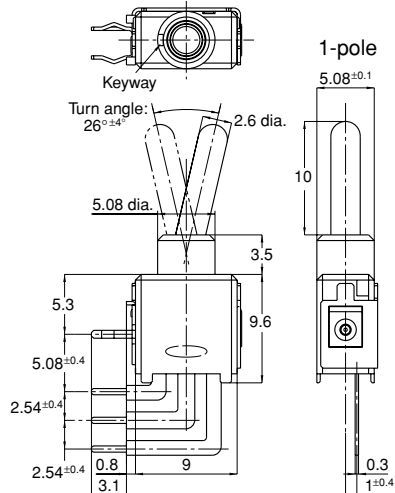

PC board pattern (Top view)

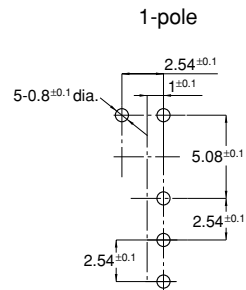

2. Push-button switch (for 5.1 dia.)

- 1) PC board terminal

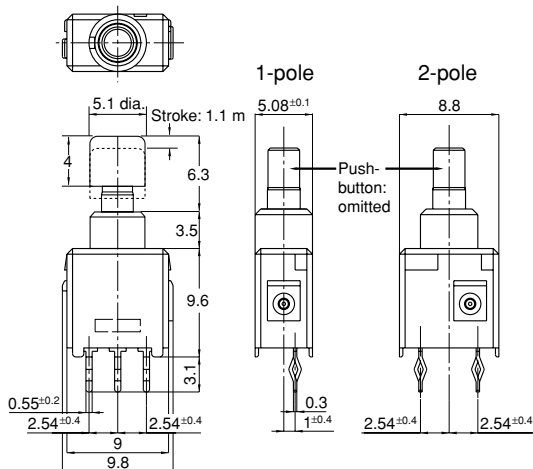

PC board pattern (Top view)

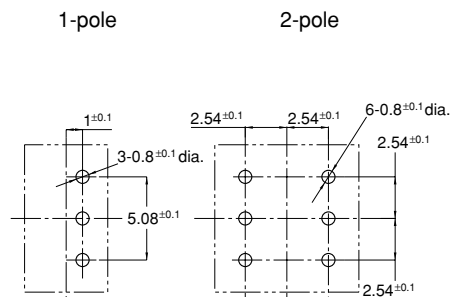

2) Bracket type

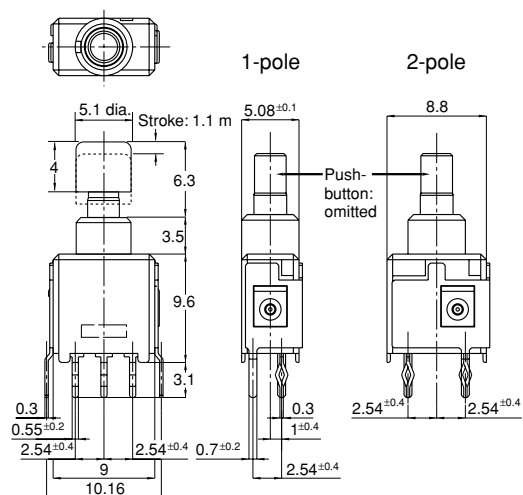

PC board pattern (Top view)

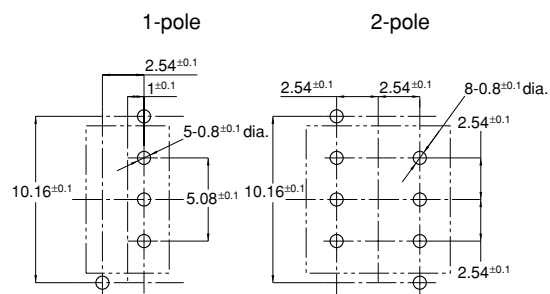

Remark: The upper side of the PC board pattern drawing is the keyway side.

3) PC-H terminal

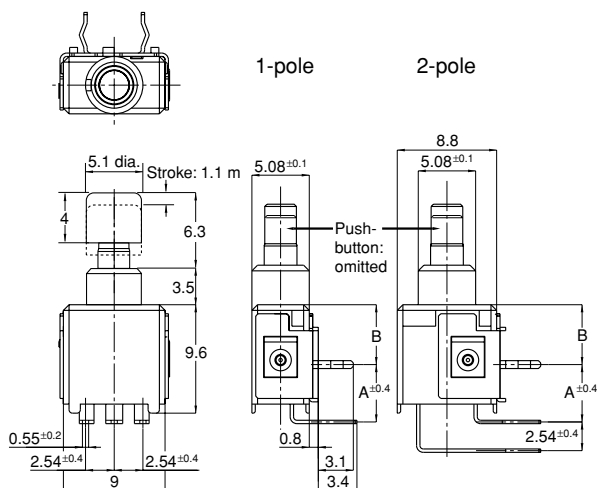

PC board pattern (Top view)

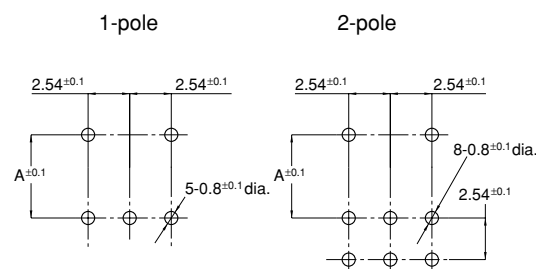

	A	B
0.2 inch pitch type	5.08	5.3
0.3 inch pitch type	7.62	2.76

4) PC-V terminal

1-pole: A Series
2-pole: A and B Series

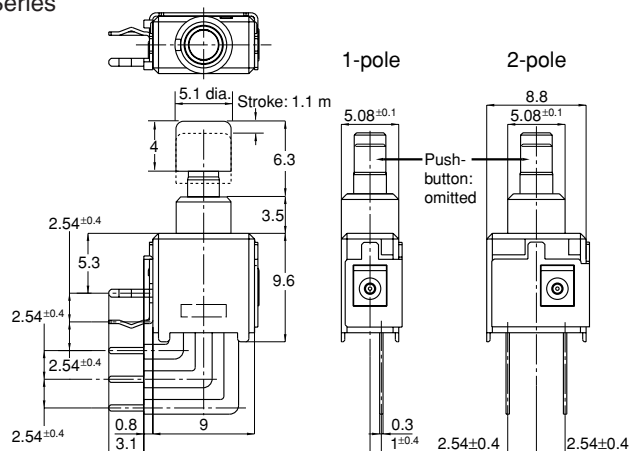

PC board pattern (Top view)

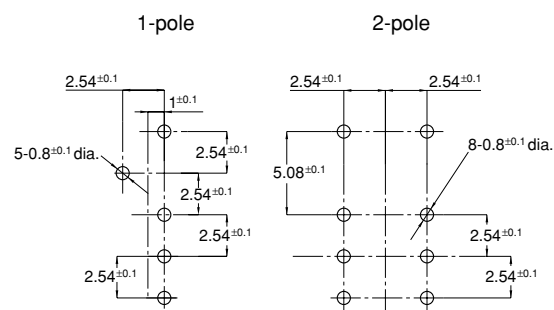

AJN1, 2

5) PC-V terminal
1-pole: B Series

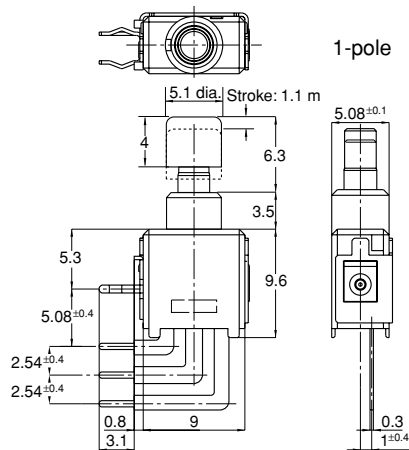

PC board pattern (Top view)

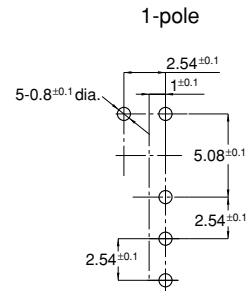

3. Color cap

1) For toggle switch

2) For push-button switch

Round color cap

Rounded flat color cap

5.1mm dia.

7.5mm dia.

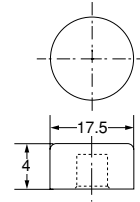
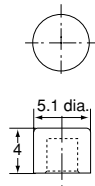
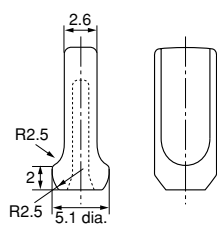
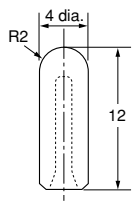

NOTES

1. Soldering operations

1) For hand soldering, a soldering iron should be used with the soldering completed within 3 seconds at a temperature of 350°C.

Force should not be applied to the terminal section. Also, care should be taken not to touch the body of the switch with the soldering iron.

2) When soldering is done with an automatic soldering bath, the soldering should be completed within 5 seconds at a bath temperature of 260°C

3) Care should be taken not to move the terminal section within 1 min after the soldering has been completed.

2. Automatic cleaning

1) Although the switch can be washed as is because it is sealed with epoxy resin and an O-ring, please verify by washing under actual conditions.

2) Do not use ultrasound for cleaning as this will adversely affect switching properties.

3) Do not operate the handle or apply a force during washing.

3. As there is a possibility of damage if the product is dropped, sufficient care should be taken to avoid dropping.

4. Once removed, the color cap will not stick back on the switch with the same tenacity as they previously exhibited.

Replace them with new one.